

## Scald Protection 3-Way Thermostatic Mixing Valve

© Copyright 2018 Caleffi

### 5213 Series

## INSTALLATION AND COMMISSIONING MANUAL



ASSE 1070

### Function

Thermostatic mixing valves are used in applications where the user must be protected from the danger of scalding caused by hot water. The Caleffi 5213 series provides water at a safe and usable temperature in situations where the control of the temperature of the water discharging from a terminal fitting is of the utmost importance, i.e. within hospitals, schools, nursing homes, etc. The valve is designed to prevent the flow of water discharging from the mixed water outlet in the event of the failure of hot or cold supply. The Caleffi 5213 series is a high performance combination thermostatic and pressure balanced mixing valve and is ASSE 1070 listed (temperature can not exceed 120°F). The valve is complete with check valve at both hot and cold inlets. Certified to ASSE 1070 and Low Lead Plumbing Law by ICC-ES.

### Product range

5213 series scald protection three-way thermostatic mixing valve.

Union thread NPT male connections, sizes 1/2", 3/4", 1"; Union sweat connection, sizes 1/2", 3/4", 1"; Union PEX crimp connections, sizes 1/2", 3/4", 1"; Compression union, size 3/8".

### Technical specifications

#### Materials:

- valve body and regulating spindle: low-lead brass (<0.25% lead content)
- Shutter, seat and slide guides: PPO
- Springs: stainless steel
- Seals: peroxide-cured EPDM
- cover: ABS

Temperature adjustment range: 85–120°F (29–50°C)

Temperature set: must be commissioned on site to achieve desired temperature

Temperature stability: ±3°F (±2°C)

Cold inlet temperature: Minimum 39°F (4°C); Maximum 85°F (29°C)

Hot inlet temperature: Minimum 120°F (49°C); Maximum 185°F (85°C)

Maximum operating differential pressure: Static: 150 psi (10 bar); Dynamic: 70 psi (5 bar)

Minimum operating differential pressure (dynamic): 1.5 psi (0.1 bar)

Maximum unbalanced dynamic supply (hot/cold or cold/hot): 6:1

Minimum temperature differential between hot water inlet and mixed water outlet to ensure thermal shutoff function: 18°F (10°C)

Minimum temperature differential between mixed water outlet and cold water inlet to ensure stable operation: 9°F (5°C)

Minimum flow rate for stable operation: 0.5 gpm (2 l/min)

#### Certifications:

1. ASSE 1070/CSA B125.3-2012, certified by ICC-ES, file PMG-1357.
2. NSF/ANSI 372-2011, Drinking Water Systems Components-Lead Content Reduction of Lead in Drinking Water, California Health and Safety Code 116875 S.3874, Reduction of Lead in Drinking Water Act, certified by ICC-ES, file PMG-1360.



## SAFETY INSTRUCTION

This safety alert symbol will be used in this manual to draw attention to safety related instructions. When used, the safety alert symbol means **ATTENTION! BECOME ALERT! YOUR SAFETY IS INVOLVED! FAILURE TO FOLLOW THESE INSTRUCTIONS MAY RESULT IN A SAFETY HAZARD.**

**⚠ WARNING:** This product can expose you to chemicals including lead, which is known to the State of California to cause cancer and birth defects or other reproductive harm. For more information go to [www.P65Warnings.ca.gov](http://www.P65Warnings.ca.gov).



**CAUTION:** All work must be performed by qualified personnel trained in the proper application, installation, and maintenance of systems in accordance with all applicable codes and ordinances.



**CAUTION:** If the thermostatic mixing valve is not installed, commissioned and maintained properly, according to the instructions contained in this manual, it may not operate correctly and may endanger the user.



**CAUTION:** Make sure that all the connecting pipework is water tight.



**CAUTION:** When making the water connections, make sure that the pipework connecting the thermostatic mixing valve is not mechanically over-stressed. Over time this could cause breakages, with consequent water losses which, in turn, could cause harm to property and/or people.



**CAUTION:** Water temperatures higher than 100°F can be dangerous. During the installation, commissioning and maintenance of the thermostatic mixing valve, take the necessary precautions to ensure that such temperatures do not endanger people.



**CAUTION:** To prevent any damage which will cause the electronic mixing valve to not operate correctly, treat highly aggressive water before entering the thermostatic mixing valve.

**Leave this manual for the user.**



## CONSIGNE DE SÉCURITÉ

Ce symbole d'avertissement servira dans ce manuel à attirer l'attention sur la sécurité concernant instructions. Lorsqu'il est utilisé, ce symbole signifie.

**ATTENTION! DEVEZ-VOUS ÊTRE ALERTES ! VOTRE SÉCURITÉ EST EN JEU ! NE PAS SUIVRE CES INSTRUCTIONS PEUT PROVOQUER UN RISQUE DE SÉCURITÉ.**

**⚠ AVERTISSEMENT:** Ce produit peut vous exposer à des produits chimiques comme le plomb, qui est connu dans l'État de Californie pour causer le cancer, dommages à la naissance ou autre. Pour plus d'informations rendez-vous [www.P65Warnings.ca.gov](http://www.P65Warnings.ca.gov).



**ATTENTION:** Tous les travaux doivent être effectués par du personnel qualifié formé à la bonne application, installation et maintenance des systèmes conformément aux codes et règlements locaux.



**ATTENTION:** Si le réducteur de pression, thermostatique réglable, n'est pas installé, mis en service et entretenu correctement, selon les instructions contenues dans ce manuel, il peut ne pas fonctionner correctement et peut mettre en danger l'utilisateur.



**ATTENTION:** S'assurer que tous les raccordements sont étanches.



**ATTENTION:** Lorsque vous effectuez les raccordements d'eau, assurez-vous que la tuyauterie reliant le thermostatique réglable n'est pas mécaniquement overstressed. Au fil du temps, ceci pourrait causer des ruptures, avec pour conséquence des pertes en eau qui, à leur tour, peuvent causer des dommages à la propriété et/ou les gens.



**ATTENTION:** Les températures de l'eau supérieures à 100°F (38°C) peuvent être dangereuses. Au cours de l'installation, mise en service et l'entretien de le réducteur de pression, le thermostatique réglable, prendre les précautions nécessaires afin de s'assurer que de telles températures ne compromettent pas les gens.



**ATTENTION:** Pour prévenir tout dommage qui provoque le mitigeur électronique à ne pas fonctionner correctement, le traitement de l'eau très agressive avant d'entrer dans la vanne de le thermostatique réglable.

**LAISSEZ CE MANUEL AVEC L'UTILISATEUR**

## Operating principle

The thermostatic mixing valve mixes hot and cold water in such a way as to maintain constant set temperature of the mixed water at the outlet. A thermostatic element is fully immersed into the mixed water. This element then contracts or expands causing movement of the piston, closing either the hot or cold inlets, regulating the flow rates entering the valve. If there are variations of temperature or pressure at the inlets, the internal element automatically reacts to restore the original temperature setting. In the event of a failure of either the hot or cold supply, the piston will shut off, stopping water discharging from the mixed water outlet.

## Thermal shutoff

In the event of a failure of either the hot or cold supply, the piston will shut off, stopping water discharging from the mixed water outlet. The Caleffi 5213 series thermostatic mixing requires a minimum temperature differential from hot inlet to mixed water outlet of 18°F (10°C) to ensure the correct operation of the thermal shutoff feature.

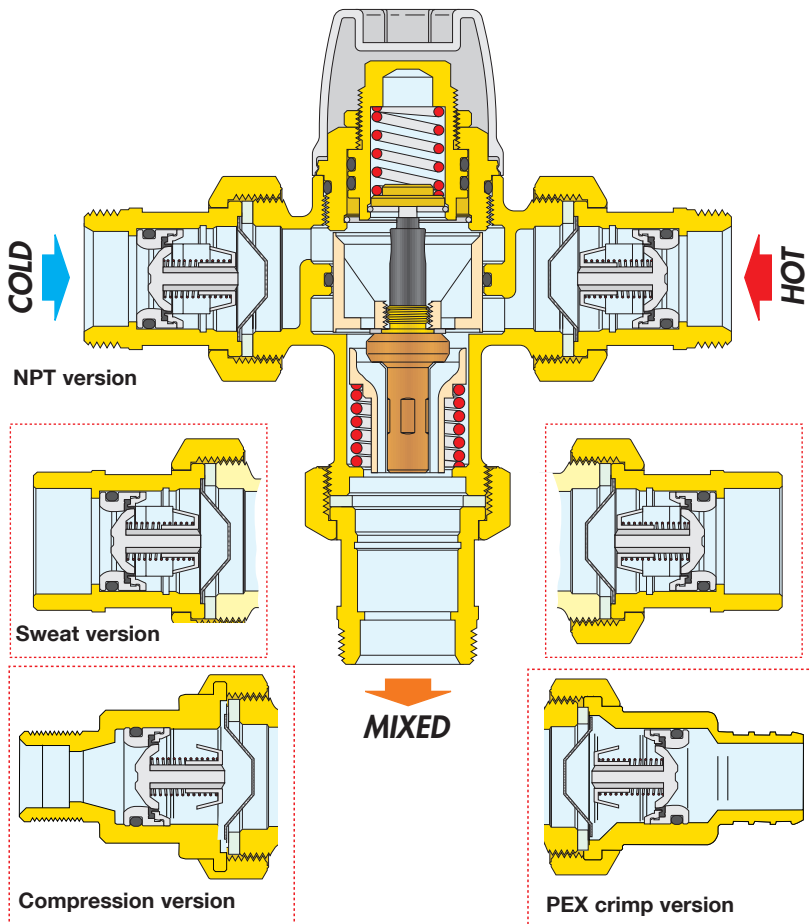

## Flow curve

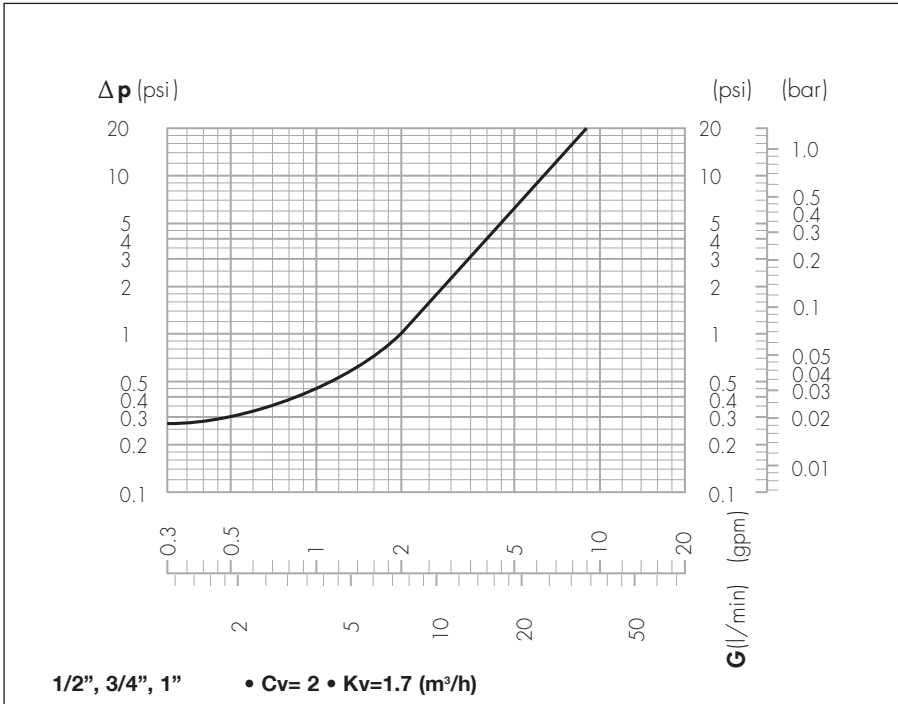

Flow should never exceed standards for pipe size and materials.

## Use

The Caleffi 5213 series is a thermostatic mixing valve suitable for **single or multiple point of use applications** in accordance with installation rules and indications specified in ASSE 1070 standards.

The system must be sized taking into account the current legislation with regard to the nominal flow rate of each outlet.

## Exploded diagram

- 1 Protective cap
- 2 Temperature spindle locking nut
- 3 Upper body
- 4 O-ring seal
- 4a O-ring seal
- 5 Thermostatic element
- 6 Flow conveyor
- 7 Lower spring
- 8 Valve body
- 9 Union washer, quantity 3 per valve
- 10 Union nut, quantity 3 per valve
- 11 Inlet port male tailpiece with integral check valve, quantity 2 per valve
- 12 Inlet port conic filter, quantity 2 per valve
- 13 Outlet port tailpiece, quantity 1 per valve

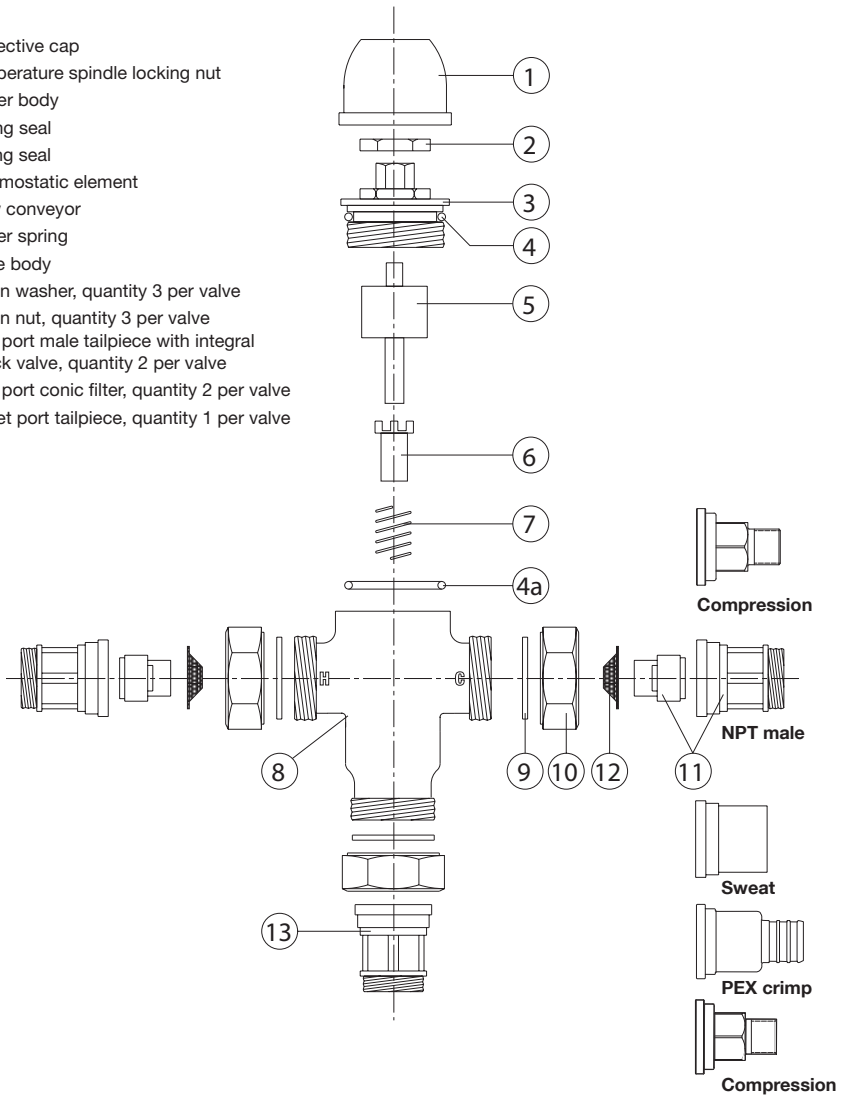

## Replacement fittings

Complete kit	Valve size	Connection	Union Nut	Tailpiece	Washer
consult Caleffi	3/8 inch	compression	F61008/C	F0000718(2)	F50055
NA20640	1/2 inch	NPT male		R31981	
NA20640C (1)				59893A(1)	
NA20649		Sweat		NA10002(1)	
NA20649C				59904A	
NA20647		PEX crimp		F0000492	
NA20647C				NA10484(1)	
NA20650	3/4 inch	NPT male		31901A	
NA20650C				59840A(1)	
NA20659		Sweat		NA10003	
NA20659C				59905A(1)	
NA20657		PEX crimp		F0000520	
NA20657C				NA10485(1)	
NA20660	1 inch	NPT male		59817A	
NA20660C			59894A(1)		
NA20669		Sweat	59834A		
NA20669C			59906A(1)		
NA20667		PEX crimp	F61008/C	F0000521	
NA20667C			NA10486(1)		

(1) C = check valve included in tailpiece. Use in inlets.

(2) Check valve not included: source separately check valve code NA10479.

## Replacement parts



Replacement check valves for 5213 series thermostatic mixing valves.



Conical inlet filter for 5213 series thermostatic mixing valves.

NA10405..... check valve for PEX fittings  
 R39204... check valve for sweat, NPT fittings  
 NA10479.....check valve for 521333A

F52429.....conical filter

## Installation

The following instructions must be read prior to the installation of a Caleffi 5213 series thermostatic mixing valve. The installer should also be aware of his responsibility and duty of care to ensure that all aspects of the installation comply with current regulations and legislation.

The Caleffi 5213 series should be installed using the appropriate standard, code of practice and legislation applicable to each state and following the details in this manual. The Caleffi 5213 series must be installed by a licensed plumber.

Prior to the installation of the Caleffi 5213 series valve, the system must be checked to ensure that the **system operating conditions fall within the recommended operating range of the valve, i.e. verify supply temperatures, supply pressures, risk assessments, etc.**

The supply system into which the Caleffi 5213 series is to be installed must be thoroughly flushed and cleaned to remove any debris which may accumulate during the installation. Failure to remove any debris will affect the performance and the manufacturer's warranty on the product. In areas that are subject to high levels of aggressive water, provision must be made to treat the water prior to it entering the valve.

The valve can be installed in any position, whether vertical or horizontal. It is essential that the access to the valve is not obstructed for future maintenance that may be required to the valve or associated fittings.

It is essential that when the installation is designed and/or installed, all current legislation is noted, e.g. the maximum distance from the outlet of the valve to any terminal fitting.

The connecting hot and cold water supplies must be connected to the valve strictly in accordance with the indications on the body of the valve. The inlets of the valves are clearly marked with the letter H (Hot) and C (Cold). The outlet is marked with the word MIX.

Where one or both the incoming supply pressures are excessive, a Caleffi pressure reducing valve should be installed to reduce the pressure(s) within the limits.

Any thermostatic mixing valve must be installed with isolating valves, line strainers and check valves at both the inlets. Isolating valves are required so that the water supply to the valve can be isolated in the event that servicing is required. Strainers are required to prevent debris from entering the valve. Check valves are required to both hot and cold inlets to prevent cross-connection.

The Caleffi 5213 series is supplied complete with the check valves at the hot and cold inlets. The check valve of the sweat version must be dismantled from the tail piece before soldering and then reassembled.

To ensure that the performance of the Caleffi 5213 series valve is maintained (in the event of cold water failure), the temperature of the hot water supply at the point of entry to the valve must be a minimum of 18°F higher than the set mixed water discharge temperature.

The piping to and from the valve must not be used to support the weight of the valve.

If the valve is not installed correctly, it will not function correctly and may put the user in danger.



# Installation diagram

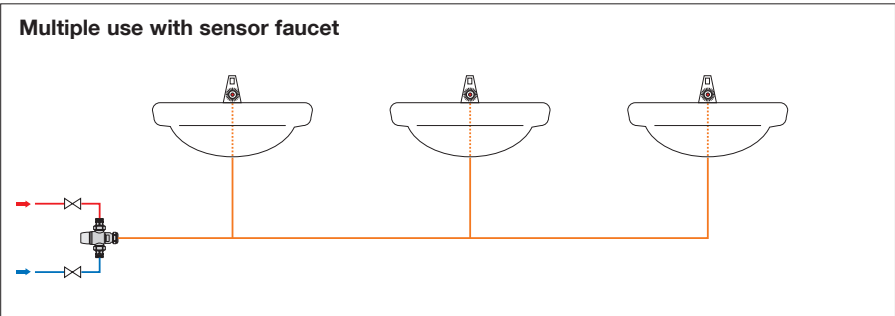
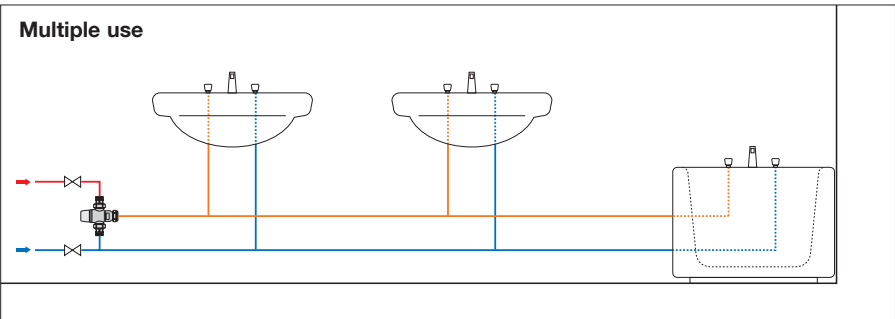
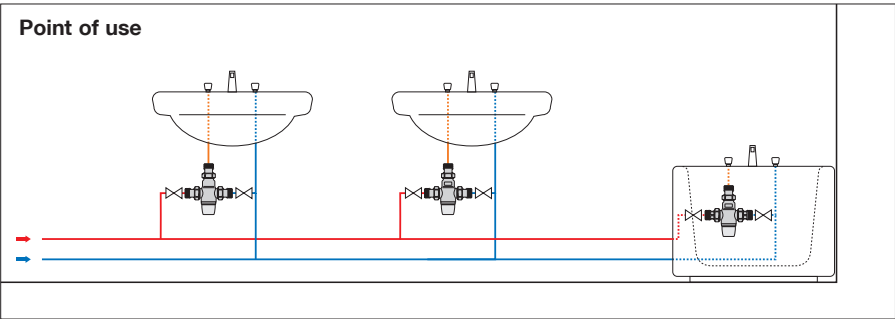
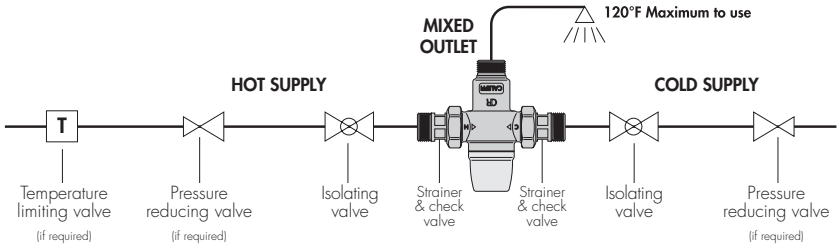

## Dimensions

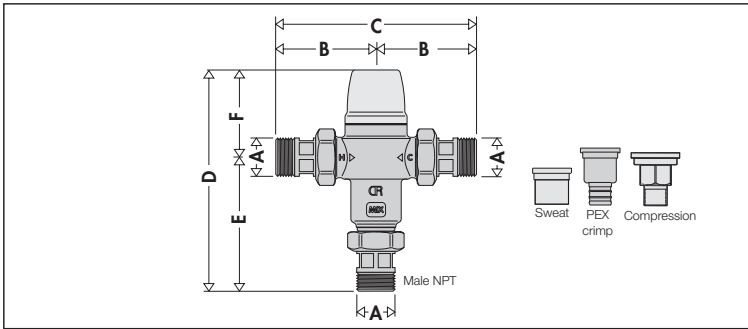

Code	A	B	C	D	E	F	Wt (lb)
521342A	1/2" NPT male	2 13/16"	5 11/16 "	4 5/16"	3"	1 15/16"	2.0
521352A	3/4" NPT male	2 13/16"	5 11/16 "	4 5/16"	3"	1 15/16"	2.0
521362A	1" NPT male	2 15/16"	5 7/8"	5 3/16"	3 1/4"	1 15/16"	2.0
521347A	1/2" PEX crimp	3"	6"	5 1/2"	3 5/8"	1 15/16"	2.0
521357A	3/4" PEX crimp	3"	6"	5 1/2"	3 5/8"	1 15/16"	2.0
521367A	1" PEX crimp	3 1/16"	6 1/8"	5 9/16"	3 11/16"	1 15/16"	2.0
521349A	1/2" sweat	2 11/16"	5 7/16 "	4 5/8"	2 11/16 "	1 15/16"	2.0
521359A	3/4" sweat	2 7/8"	5 3/4"	4 13/16 "	2 15/16 "	1 15/16"	2.0
521369A	1" sweat	3 1/8"	5 5/16"	5 3/8"	3 1/4"	1 15/16"	2.0
521333A	3/8" compression	2 11/16"	5 3/8"	5 3/16"	3 5/16 "	1 15/16"	2.0

## Commissioning

Upon completion of the installation, the valve should be tested and commissioned as per the procedure outlined below or as specified by the local authority.

The following instructions should be read and understood prior to commissioning the Caleffi 5213 series thermostatic mixing valve. If, under any circumstances, there are aspects of the installation/system which do not comply with our requirements or the specifications as listed, the valve must not be put into service until the installation/system does comply.

- 1) Ensure that the system is thoroughly clean and free from debris prior to commissioning the thermostatic mixing valve.
- 2) Use a suitably calibrated and accurate digital thermometer to commission temperatures. The valve is commissioned by measuring the mixed water temperature at the outlet.
- 3) In accordance with the anti-scald requirements, water installation shall deliver hot water at the outlet of the sanitary fixtures used primarily for personal hygiene purposes at a temperature not exceeding:
  - 120°F (49°C) or as specified by authority having jurisdiction.
- 4) The temperature at the outlet of each valve must be set taking into consideration any fluctuations which may occur within the system due to simultaneous demand.
- 5) Once the supply temperatures are stabilized and the normal operating conditions are established, the valve can be commissioned. Due to the unique design of the cap, the temperature setting can be adjusted by removing the cap from the valve body and reversing the cap onto the temperature adjustment spindle. Use the following sequence when commissioning the valve.
  - a) Set the mixed water discharge temperature to the required temperature.
  - b) Measure and record the temperature of hot and cold water supplies at the connections to the valve.
  - c) Measure and record the temperature of the water discharging from the largest and smallest volume draw off points.
  - d) Perform the thermal shut-off test. Isolate the cold water supply to the Caleffi valve and monitor the mixed water temperature. The outlet flow should quickly cease flowing.
  - e) Measure and record the maximum mixed water temperature. The temperature should not exceed the temperature allowed by the applicable standard or code of practice for each state.
  - f) Restore the cold water supply to the valve and measure and record the outlet temperature after the mixed water temperature has stabilized. The final temperature found during this test should not exceed the permitted values +3°F.
- 6) Once the desired temperature has been reached, the adjustment spindle can be locked in position using the locking nut supplied with the valve.
- 7) Once the desired temperature is established, remove the cap from the temperature adjustment spindle and secure the head back on to the valve into its original position to prevent tampering by unauthorised persons.

We recommend that the above information is recorded in the Commissioning Report and updated on the Service Report when any work is performed on the valve.

## Temperature adjustment

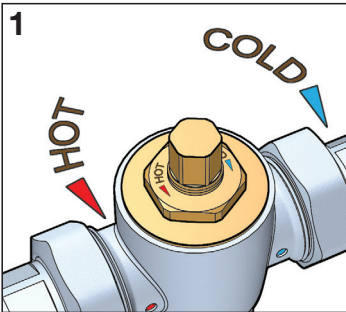

◀ View of temperature adjustment

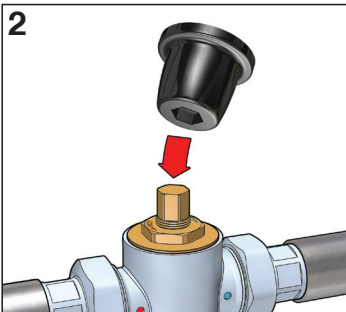

◀ Attaching temperature adjustment cap

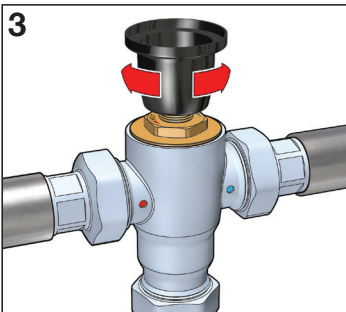

◀ Temperature adjustment cap in place

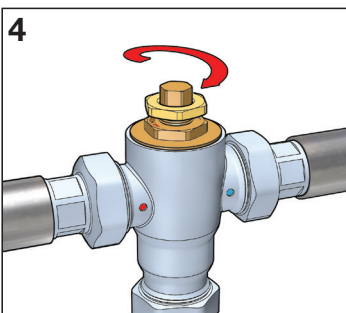

◀ Locking adjustment spindle with locking nut

## Maintenance

In service tests should be conducted regularly to monitor and record the performance of the valve. Deterioration in performance can indicate the need for servicing of the valve and/or water supply. If, during these tests, the mixed water temperature has changed significantly from the previous test results, record the change before re-adjusting the mixed water temperature. If the final mixed water temperature is greater than the permitted values, Verify details quoted in the Installation and Commissioning sections of this manual and that service work is required.

The following actions are recommended at least every 12 months, or more frequently if the need arises, and that the following steps are checked to maintain optimum valve performance.

With reference to the exploded diagram on page 6:

- 1) On the Caleffi 5213 series valves, the inlet conic filters (12) on both the hot and cold water supplies can be removed for cleaning by unscrewing the inlet union nuts and carefully pulling apart the connecting piping.
- 2) The built in check valves (11) on the Caleffi 5213 series valves can be accessed in a similar way to 1) to ensure freedom of operation and correct operation.
- 3) If service is required, the internal components of the valve can be disassembled for cleaning and de-scaling:
  - a) Remove the cap of the valve (1) and the locking nut (2).
  - b) Remove the upper body (3) using a suitable spanner.
  - c) Remove parts 5-7 noting the correct orientation.
  - d) Remove all signs of scale and dirt from the internal part using a suitable de-scaling solution.
  - e) Re-assemble all the components.

Once the above servicing is performed follow the commissioning details in the previous section ensuring that a suitably accurate thermometer is used.

Should the valve still not function correctly, it may be necessary to replace the thermal element or other components. Refer to spare part kits and contact Caleffi Technical Support for details and advice.

## Spare parts

With reference to the exploded diagram, the spare parts are available on request for Caleffi 5213 series valves, see table on page 7.

## Troubleshooting

Under normal operating conditions the Caleffi 5213 series thermostatic mixing valve will provide a very high level of performance. However, in some circumstances, when the included maintenance plan is not properly performed, the following problems may arise.

<b>Sympton</b>	<b>Cause</b>	<b>Corrective action</b>
Hot water at the cold faucets	<ul style="list-style-type: none"> <li>a) Inserted check operation failed.</li> <li>b) Check valves not installed.</li> </ul>	Replace faulty check valves.
Fluctuating mixed water temperature	<ul style="list-style-type: none"> <li>a) Erratic supply temperatures at the valve inlets.</li> <li>b) Starvation of the water supplies at the valve inlets.</li> <li>c) Incorrect commissioning of the valve.</li> </ul>	Restore inlet conditions within the limits of the valve.
Erratic flow of water from the valve	<ul style="list-style-type: none"> <li>a) Insufficient water supplies.</li> <li>b) Fluctuations in supply pressure and/or temperatures.</li> <li>c) Adverse effect created by other draw-off points on the sytem.</li> </ul>	Stabilize inlet supply conditions.
No water flowing from the valve	<ul style="list-style-type: none"> <li>a) In-line filters blocked.</li> <li>b) Insufficient supply pressures.</li> <li>c) Debris obstructing valve operation.</li> </ul>	<ul style="list-style-type: none"> <li>a) Clean filters.</li> <li>b) Restore inlet supplies.</li> <li>c) Clean debris or scale from valve internals.</li> </ul>
Valve does not shutoff when tested	<ul style="list-style-type: none"> <li>a) Installation not in accordance with this instruction manual.</li> <li>b) Minimum temperature differential not achieved.</li> <li>c) Internal mechanism impaired by debris.</li> </ul>	<ul style="list-style-type: none"> <li>a) Install as outlined in these instructions.</li> <li>b) Raise hot water temperature.</li> <li>c) Clean debris or scal from valve.</li> </ul>

this page left blank intentionally



**Caleffi North America, Inc.**  
**3883 West Milwaukee Road**  
**Milwaukee, WI 53208**  
**T: 414.238.2360 F: 414.238.2366**

4-30-18