

FLOWING EXPERTISE

FEBRUARY 2021



PLUMBING AND
HYDRONICS
CATALOG



FLOWING EXPERTISE

With our heating and plumbing solutions, we have been redesigning the comfort of the spaces we live and work in for over 60 years. This is thanks to the flow of expertise, technology, experience and innovations that we have acquired over the years by constantly exchanging ideas with our customers and suppliers. A flow that pushes boundaries, allowing us to constantly set the benchmark. A flow that allows us to always look one step ahead into the future.



FLOW OF LIFE

A unique way of flowing. It is **continuous change**, a high degree of reliability in our work, and the ongoing pursuit of total quality, which is the result of small daily actions.



FUTURE

Innovation aimed at creating **new forms of comfort** for spaces, which motivates us to continue to grow and improve.



SUSTAINABILITY

Our focus on preserving **environmental, social and economic well-being** so that it can be passed on to future generations through our products and processes.



TECHNOLOGY

Our ability to do research, invest in processes and develop **state-of-the-art solutions** in an ever-evolving world of expertise.



MADE IN CALEFFI

A uniqueness consisting of many details, which is what we are known for worldwide. True **"Made in Italy"** quality, the hallmark of our company.



1 HYDRAULIC SEPARATORS

2 AIR AND DIRT SEPARATION AND AIR VENTS

3 THERMOSTATIC RADIATOR VALVES

4 ZONE VALVES AND ZONE CONTROLS

5 DISTRIBUTION MANIFOLDS AND TEMPERATURE MIXING STATIONS

6A MIXING VALVES FOR PLUMBING AND HYDRONICS

6B BALANCING VALVES FOR PLUMBING AND HYDRONICS

6C PRVS, BACKFLOW PREVENTERS AND AIR VENT

7 FILLING UNITS AND BOILER TRIM KITS

8 FITTINGS AND MISCELLANEOUS COMPONENTS

9 RENEWABLES, SOLAR, GEOTHERMAL AND BIOMASS DEVICES

10 HEAT METERS

11 INDEX

Hydronics Product Selector

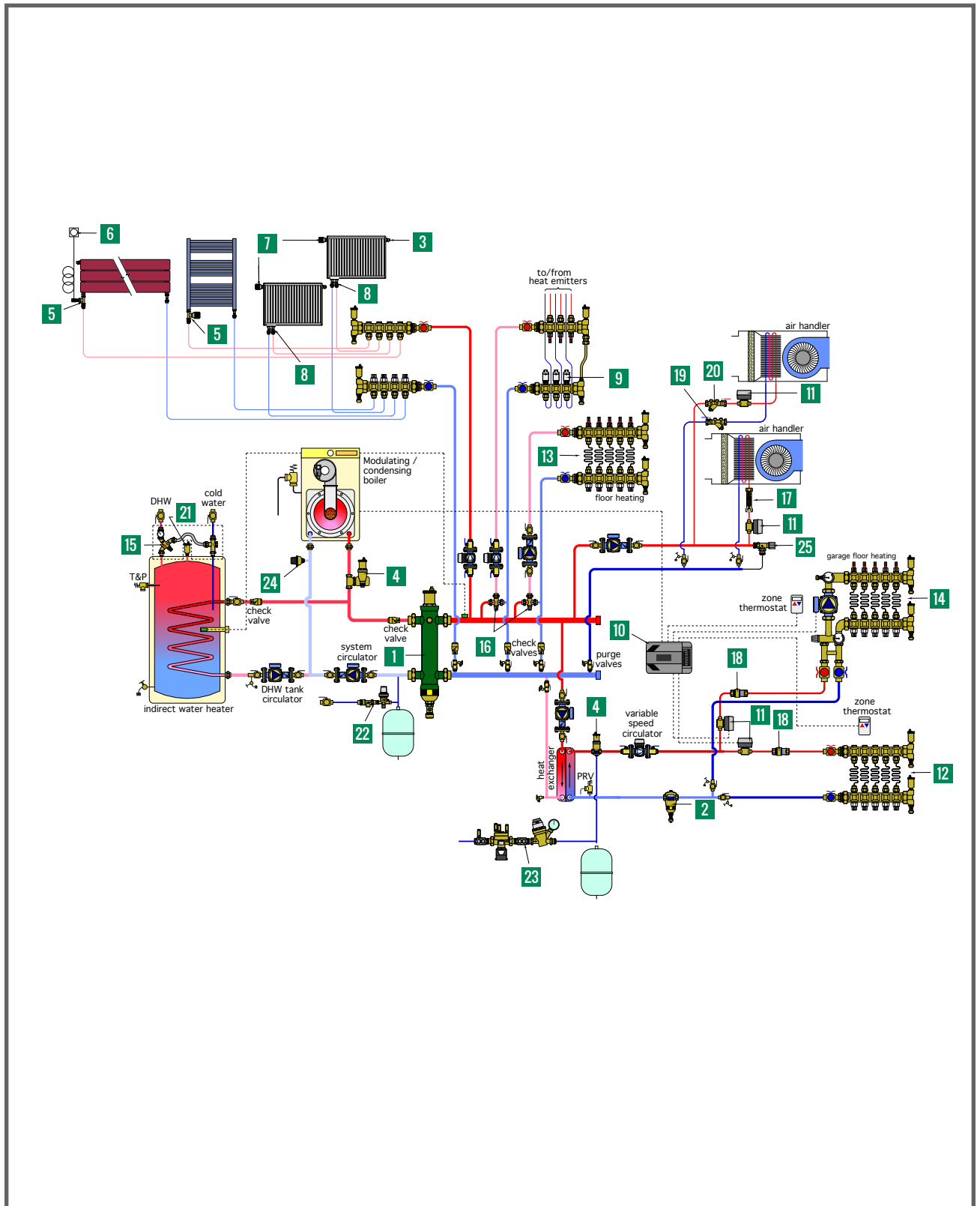

Key	Part Number	Description	Catalog Section
1	549506A	SEP4™ hydraulic, air, dirt, mag separator	1
2	546306A	DIRTMAG® Magnetic Dirt Separator	2
3	508013A*	Hygroscopic air vent	2
4	551706A	DISCAL® air separator, rotating collar	2
5	221500*	Radiator valve	3
6	472000*	Remote wall sensor	3
7	200000*	Radiator valve control head	3
8	301040*	Radiator connection valves	3
9	656344*	TwisTop™ thermo-electric actuator	3 & 5
10	ZVR103	Z-one™ valve relay control	4
11	Z55P	Z-one™ valve assembly	4
12	6636E5A*	Manifold	5
13	6686E5S1A*	TwistFlow™ manifold	5
14	1725E1AHE*	Manifold mixing station	5
15	520510AX	TankMixer™ thermostatic mixing assembly	6A
16	521619A*	MixCal™ thermostatic mixing valve	6A
17	132662A	QuickSetter™ balancing valve	6B
18	127361AF*	FlowCal™ automatic balancing valve	6B
19	121161A*	FlowCal™ automatic balancing valve	6B
20	120161A*	Y-strainer	6B
21	NA502640A	PLUMBVENT™ low lead automatic air vent	6C
22	573002A	AutoFill™ combo ASSE 1012	7
23	574151A	AutoFill™ combo ASSE 1013	7
24	626600A*	Paddle flow switch	8
25	519600A*	Differential Pressure bypass valve	8

Residential

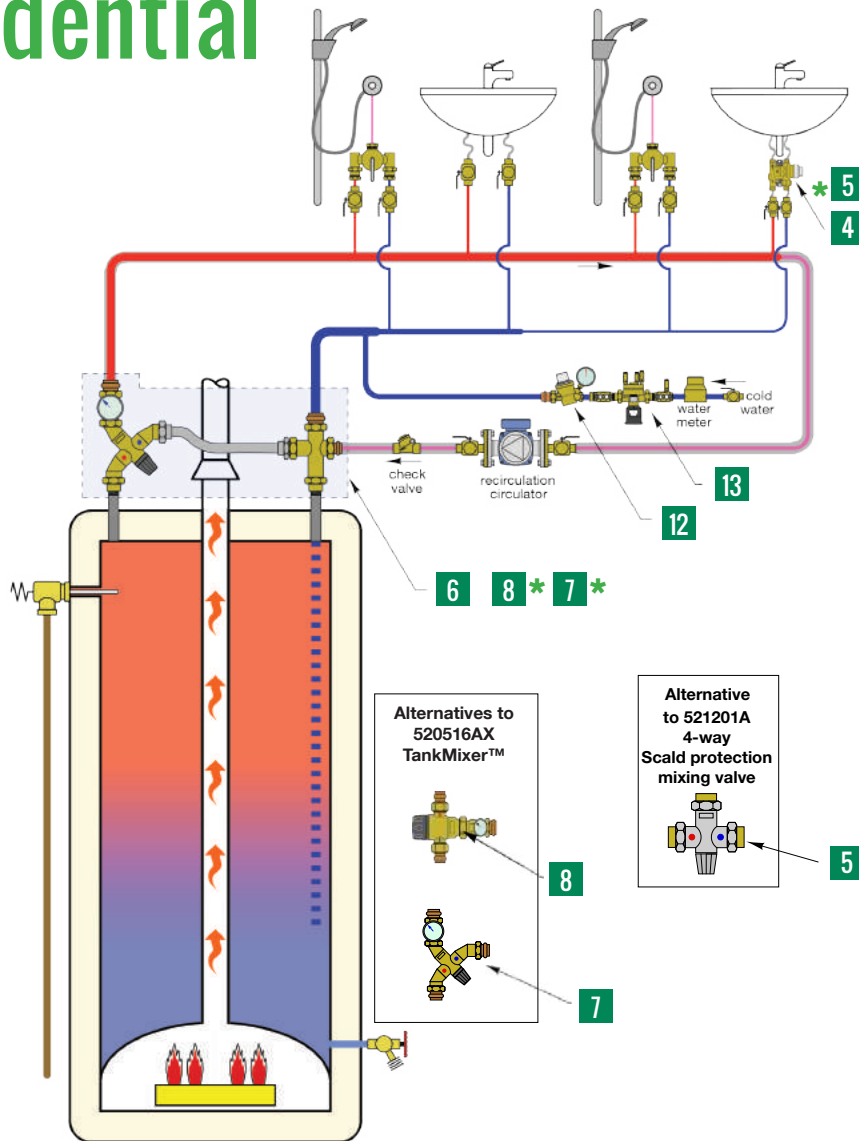

*Alternatives for mixing.

Key	Part Number	Description	Catalog Section
8	521616A	MixCal™ mixing valve ASSE 1017	6A
9	132537AFC	QuickSetter+™ manual balancing valve	6B
10	127356AF*	FlowCal™ automatic balancing valve	6B
11	116151AC	ThermoSetter™ thermal balancing valve	6B
12	533351HA	PresCal™ pressure reducing valve ASSE 1003	6C
13	574050A	RPZ backflow preventer ASSE 1013	6C
14	NA502640A	PLUMBVENT™ low lead automatic air vent	6C
15	535991HA	PresCal™ pressure reducing valve ASSE 1003	6C

HIGH PERFORMANCE MULTI-FUNCTION HYDRAULIC SEPARATOR



The Caleffi SEP4™ saves on system installation and maintenance costs with four high performance functions combined into one device: hydraulic separation, micro-bubble coalescing air separation, dirt separation and magnetic separation. **CALEFFI GUARANTEED.**



HYDRAULIC SEPARATORS

This diagram is for illustration purposes only

1

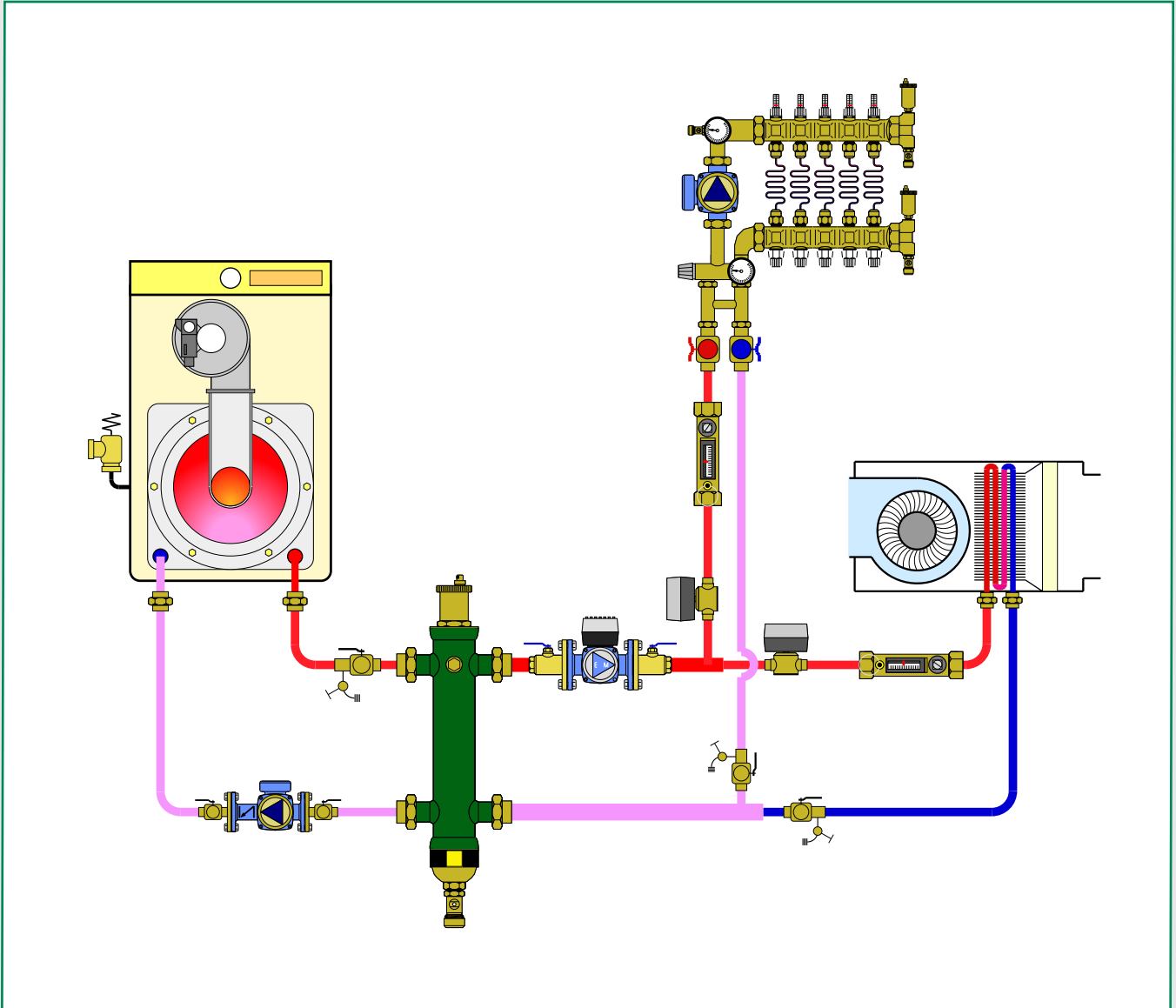

PRODUCTS INCLUDED IN SECTION

- 4-in-1 hydraulic separators
- Hydraulic separators
- Combination hydraulic separators and manifold
- Hydraulic separator accessories

4-IN-1 HYDRAULIC SEPARATORS



**5495
SEP 4™**

Combination 1. air, 2. hydraulic and 3. dirt separation, plus 4. magnetic separation. Epoxy resin coated steel body. HDPE internal coalescing element, removable for cleaning. Includes mounting bracket. Thermowell tap: 1/2" straight female. Max. working pressure: 150 psi. Working temperature range: 32–212°F.

Code	Description	Lbs	USD
549596A	1" sweat union	15	763.00
549506A	1" NPT female union	15	793.00
549566A	1" press union	15	834.00
549597A	1¼" sweat union	19	930.00
549507A	1¼" NPT female union	19	962.00
549567A	1¼" press union	19	1,057.00
549598A	1½" sweat union	27	1,214.00
549508A	1½" NPT female union	27	1,258.00
549568A	1½" press union	27	1,373.00
549599A	2" sweat union	29	1,393.00
549509A	2" NPT female union	29	1,428.00
549569A	2" press union	29	1,604.00
549506US*	1" no tailpieces	13	650.00
549507US*	1¼" no tailpieces	16	758.00
549508US*	1½" no tailpieces	23	894.00
549509US*	2" no tailpieces	24	1,084.00

*See Separator fittings in Section 8.



**NA549
SEP 4™
ASME**

Combination 1. air, 2. hydraulic and 3. dirt separation, plus 4. magnetic separation. Three neodymium magnet assemblies. Complete with: automatic air vent (code 501502A). air vent shut-off valve (code NA39589). drain valve (code NA59600). ANSI 150 flange connections. Thermometer pockets (NPT): ½" inlet/outlet flanges, ¾" front center Max. working pressure: 150 psi. Vessel temperature range: 32–270°F. Particle separation capacity: to 5 µm (0.2 mil). CRN registered thru 12". Consult factory for 14".

Code	Description	Lbs	USD
NA549200AM	8" ANSI flange ASME & CRN	530	17,086.00
NA549250AM	10" ANSI flange ASME & CRN	740	23,149.00
NA549300AM	12" ANSI flange ASME & CRN	1,110	30,464.00
NA549350AM	14" ANSI flange ASME	1,550	35,915.00



**NA549
SEP 4™**

Combination 1. air, 2. hydraulic, 3. dirt separation, plus 4. magnetic separation. Epoxy resin coated steel body. Stainless steel internal coalescing mesh. Pre-formed insulation on 2" – 4" sizes. One neodymium magnet assembly. Complete with: automatic air vent (code 501502A). air vent shut-off valve (code NA39589). 1" drain valve NA39753 (2" – 4" sizes) 1¼" drain valve NA39588 (5" – 6" sizes). ANSI 150 flange connections. Max. working pressure: 150 psi. Vessel temperature range: 32–220°F. Working temp. w/o insulation: 32–270°F. Particle separation capacity: to 5 µm (0.2 mil).

Code	Description	Lbs	USD
549552A	2" ANSI flange	76	3,641.00
549562A	2½" ANSI flange	82	3,881.00
549582A	3" ANSI flange	112	4,856.00
549510A	4" ANSI flange	120	5,439.00

Code	Description	Lbs	USD
NA549052AM	2" ANSI flange ASME & CRN	76	4,239.00
NA549062AM	2½" ANSI flange ASME & CRN	82	4,551.00
NA549082AM	3" ANSI flange ASME & CRN	112	5,633.00
NA549102AM	4" ANSI flange ASME & CRN	120	5,940.00
NA549120AM*	5" ANSI flange ASME & CRN	220	8,184.00
NA549150AM*	6" ANSI flange ASME & CRN	235	9,872.00

*Without insulation

NA prefix indicates ASME U-stamp tagged and registered with the National Board of Boiler and Pressure Vessel Inspectors; CRN registered.



In the SEP4™ hydraulic separators ferrous impurities are captured by a concentrated magnetic field created by a stack of neodymium magnetic rods, rare-earth magnets positioned inside a brass dry-well which is below the flow stream. Non-magnetic dirt particles are separated by colliding with an internal element in the flow stream and settling to the bottom. The deep collection chamber keeps the dirt from re-entering the flow stream. The dirt and ferrous impurities are flushed out even while the system is still running, by removing the magnets and opening the purge valve.

Size	1"	1¼"	1½"	2"
GPM	11	18	26	37
Gallons	0.5	0.7	1.3	3.5

Size	2"	2½"	3"	4"	5"	6"	8"	10"	12"	14"
GPM	60	80	124	247	300	484	792	1330	1850	2500
Gallons	4.0	4.0	8.0	8.0	23	23	95	175	255	450

HYDRAULIC SEPARATORS



**548
Hydro Separator**

Hydraulic separator.
Epoxy resin coated steel body.
300 series stainless steel internal baffle.
Includes mounting bracket.
Thermowell tap: 1/2" straight female
Max. working pressure: 150 psi.
Working temperature range: 32—212°F.

Code	Description	Lbs	USD
548006A	1" NPT female union	13	546.00
548066A	1" press union	13	585.00
548096A	1" sweat union	13	518.00
548007A	1¼" NPT female union	17	655.00
548067A	1¼" press union	17	745.00
548097A	1¼" sweat union	17	625.00
548008A	1½" NPT female union	25	859.00
548068A	1½" press union	25	967.00
548098A	1½" sweat union	25	817.00
548009A	2" NPT female union	27	1,000.00
548069A	2" press union	27	1,221.00
548099A	2" sweat union	27	955.00
548006US*	1" no tailpieces	11	410.00
548007US*	1¼" no tailpieces	14	463.00
548008US*	1½" no tailpieces	21	513.00
548009US*	2" no tailpieces	22	565.00

*See Separator fittings in Section 8.



**NA548
Hydro Separator
ASME**

Hydraulic separator.
Without insulation.
Complete with:
automatic air vent (code 501502A).
shut-off valve (code NA39589).
drain valve (code NA59600).
ANSI 150 flange connections.
Thermometer pockets (NPT):
½" inlet/outlet flanges, ¾" front center.
Max. working pressure: 150 psi.
Working temperature range: 32—270°F.
Baffle plates for all sizes: 304SST
ASME U-stamp tagged and registered with
the National Board of Boiler and Pressure
Vessel Inspectors; CRN registered thru
12". Consult factory for 14".

Code	Description	Lbs	USD
NA548200A	8" ANSI flange ASME & CRN	530	11,455.00
NA548250A	10" ANSI flange ASME & CRN	740	16,170.00
NA548300A	12" ANSI flange ASME & CRN	1,110	19,571.00
NA548350A	14" ANSI flange ASME	1,550	31,212.00



**NA548
Hydro Separator**

Hydraulic separator.
Epoxy resin coated steel body.
Pre-formed insulation on 2" — 4" sizes.
Complete with:
automatic air vent (code 501502A).
shut-off valve (code NA39589).
drain valve (code NA39588).
ANSI 150 flange connections.
Max. working pressure: 150 psi.
Vessel temperature range: 32—220°F.
Vessel temp. w/o insulation: 32—270°F.
Baffle plates for all sizes: 304SST

Code	Description	Lbs	USD
548052A	2" ANSI flange	75	2,406.00
548062A	2½" ANSI flange	82	2,563.00
548082A	3" ANSI flange	112	3,207.00
548102A	4" ANSI flange	117	3,589.00

Code	Description	Lbs	USD
NA548052A	2" ANSI flange ASME & CRN	75	3,165.00
NA548062A	2½" ANSI flange ASME & CRN	82	3,404.00
NA548082A	3" ANSI flange ASME & CRN	112	4,119.00
NA548102A	4" ANSI flange ASME & CRN	117	4,355.00
NA548120A*	5" ANSI flange ASME & CRN	220	6,084.00
NA548150A*	6" ANSI flange ASME & CRN	231	7,382.00

NA prefix indicates ASME U-stamp tagged and registered with the National Board of Boiler and Pressure Vessel Inspectors; CRN registered.
*Without insulation



**NA549
HydroCal™
ASME**

Combination 1. air, 2. hydraulic and 3. dirt
separation.
Epoxy resin coated steel body.
Stainless steel internal coalescing mesh.
Pre-formed insulation on 2" — 4" sizes.
Complete with: automatic air vent, air vent
shut-off valve, drain valve.
ANSI 150 flange connections.
Max. working pressure: 150 psi.
Vessel temperature range: 32—220°F.
Working temp. w/o insulation: 32—270°F.
Particle separation capacity: to 5 µm (0.2 mil).
CRN registered thru 12".
Consult factory for 14".

Code	Description	Lbs	USD
NA549052A	2" ANSI flange ASME & CRN	73	4,115.00
NA549062A	2½" ANSI flange ASME & CRN	79	4,426.00
NA549082A	3" ANSI flange ASME & CRN	108	5,353.00
NA549102A	4" ANSI flange ASME & CRN	117	5,660.00
NA549120A*	5" ANSI flange ASME & CRN	190	7,905.00
NA549150A*	6" ANSI flange ASME & CRN	231	9,591.00
NA549200A*	8" ANSI flange ASME & CRN	520	15,497.00
NA549250A*	10" ANSI flange ASME & CRN	730	21,560.00
NA549300A*	12" ANSI flange ASME & CRN	1,100	28,875.00
NA549350A*	14" ANSI flange ASME	1,540	34,326.00

*Without insulation

COMBINATION HYDRAULIC SEPARATORS AND MANIFOLD

**5599
HydroLink™**

Hydraulic separator + distribution manifold. 2+0 with built-in mounting. Steel body with pre-formed insulation. Complete with automatic air vent (code 502043A) and drain valve (code 538402 FD).
Max. working pressure: 100 psi.
Working temperature range: 32—230°F.
Outlet center dimension: 125 mm.
Compatible with 165, 166, 167 series HydroMixer™.



Code	Description	Lbs	USD
559920A	1" FNPT primary, 1" MNPT secondary (2)	16	770.00

**5599
HydroLink™**

Hydraulic separator + distribution manifold. 2+2 with angle mounting brackets. Steel body with pre-formed insulation. Complete with automatic air vent (code 502043A) and drain valve (code 538402 FD).
Max. working pressure: 100 psi.
Working temperature range: 32—230°F.
Outlet center dimension: 125 mm.
Compatible with 165, 166, 167 series HydroMixer™.



Code	Description	Lbs	USD
559922A	1/4" FNPT primary, 1" MNPT secondary (4)	29	947.00

**5599
HydroLink™**

Hydraulic separator + distribution manifold. 2+1 with built-in mounting. Steel body with pre-formed insulation. Complete with automatic air vent (code 502043A) and drain valve (code 538402 FD).
Max. working pressure: 100 psi.
Working temperature range: 32—230°F.
Outlet center dimension: 125 mm.
Compatible with 165, 166, 167 series HydroMixer™.



Code	Description	Lbs	USD
559921A	1" FNPT primary, 1" MNPT secondary (3)	16	793.00

**5599
HydroLink™**

Hydraulic separator + distribution manifold. 3+1 with angle mounting brackets. Steel body with pre-formed insulation. Complete with automatic air vent (code 502043A) and drain valve (code 538402 FD).
Max. working pressure: 100 psi.
Working temperature range: 32—230°F.
Outlet center dimension: 125 mm.
Compatible with 165, 166, 167 series HydroMixer™.



Code	Description	Lbs	USD
559931A	1/4" FNPT primary, 1" MNPT secondary (4)	39	1,137.00

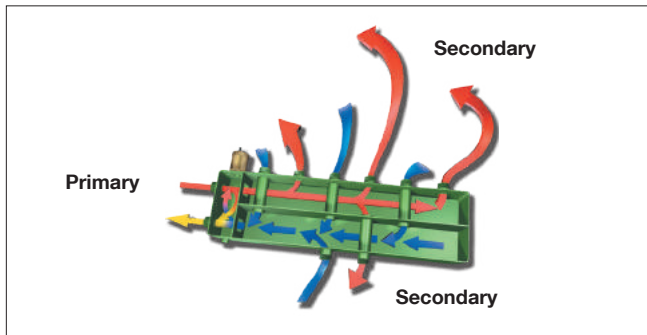

Maximum recommended flow rates at connections:

Branches	Primary	Secondary Total
2+0	9 gpm	22 gpm
2+1	9 gpm	22 gpm
2+2	11 gpm	26 gpm
3+1	11 gpm	26 gpm

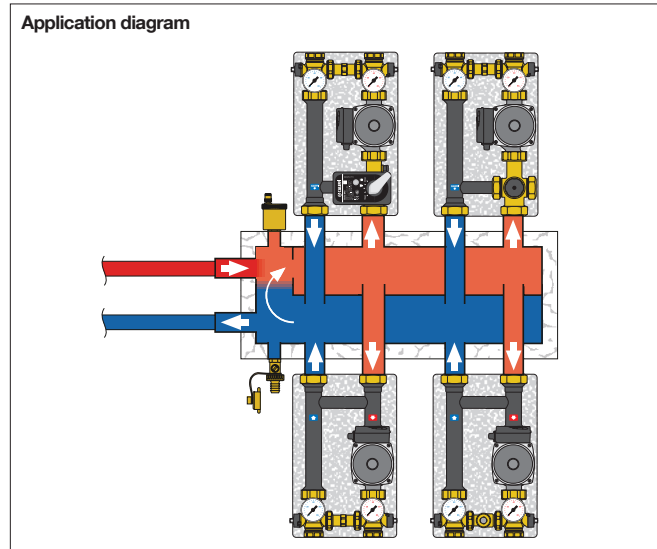

HYDRAULIC SEPARATOR ACCESSORIES



**501
MAXCAL™**

Replacement air vent for Hydro Separator. Fits NA548 Series and NA549 Series. Max. working pressure: 230 psi. Max. discharge pressure: 90 psi. Max. working temperature: 250°F. Discharge top thread: 3/8" female.

Code	Description	Lbs	USD
501502A	3/4" FNPT	7	248.00



**5020
MINICAL™**

Replacement high capacity air vent for 5599 HydroLink™. Max. working pressure: 150 psi. Max discharge pressure: 32 psi. Max. working temperature: 250°F.

Code	Description	Lbs	USD
502043A	1/2" MNPT	0.6	19.60



**5023
VALCAL™**

Replacement high capacity air vent with service check valve fits Hydro Separator 548 series. Max. working pressure: 150 psi. Max. discharge pressure: 60 psi. Max. working temperature: 250°F.

Code	Description	Lbs	USD
502343A	1/2" MNPT	0.5	39.70

NEW



Support bracket.

Code	Description	Lbs	USD
NA10778	for 1" and 1 1/4" union 5495, 548	2	23.00
NA10796	for 1-1/2" union 5495, 548	2.5	24.00
NA10797	for 2" union 5495, 548	4	25.00



Replacement drain valve fits Hydro Separator 548 series and HydroLink™ 559 series. 3/4" garden hose thread with cap. Max. working pressure: 150 psi. Max. working temperature: 250°F.

Code	Description	Lbs	USD
538402 FD	1/2" NPT x 3/4" GHT	0.3	12.50



Drain ball valves fit HydroCal™, Hydro Separators, DISCAL®, DISCALDIRT® and DIRTICAL®. Brass body. Max. working pressure: 150 psi. Max. working temperature: 365°F.

Code	Description	Lbs	USD
NA39589	3/4" FNPT w/T-handle, air vent isolate	0.8	25.80
NA39753	1" FNPT w/Lever, drain	0.7	35.10
NA39588	1 1/4" FNPT w/Lever, drain	1	59.10
NA59600	2" FNPT w/Lever, drain	4	125.00



Temperature pocket well fits 1", 1 1/4", 1 1/2" & 2" 548 / 5495 Hydro Separators. 1 3/4" pocket length. Inside thread: 20 x1.0 mm.

Code	Description	Lbs	USD
694045	1/2" straight thread	0.2	15.80
R20011	Sealing washer	0.1	1.30
NA10426	Sensor holding grommet	0.1	3.60
NA10425	Kit containing above 3 items	0.4	21.20



Magnetic/drywell assembly for SEP4™.

Code	Description	Lbs	USD
F0000435	Fits 2" and 2 1/2"	0.3	118.00
49684A	Fits 3" — 6"	0.3	267.00
F0000349	Fits 8" to 14"	0.3	504.00

NEW



Insulation jacket kit.

Code	Description	Lbs	USD
NA10801	for 1" union 5495	0.5	40.00
NA10802	for 1 1/4" union 5495	0.5	44.00
NA10803	for 1 1/2" union 5495	0.6	60.00
NA10804	for 2" union 5495	0.6	68.00
NA10805	for 1" union 548	0.5	26.00
NA10806	for 1 1/4" union 548	0.5	30.00
NA10807	for 1 1/2" union 548	0.6	37.00
NA10808	for 2" union 548	0.6	43.00

THE GOLD STANDARD FOR HEALTHY HYDRONIC SYSTEM FLUIDS



The DISCAL® air separator and DIRTMAG® dirt separator duo helps ensure maximum protection and efficiency in hydronic systems. The DISCAL high efficiency air separator features a large, low-flow zone, coalescing element and automatic air vent to minimize corrosion formation. The DIRTMAG's magnetic technology and particle mesh removes both ferrous and non-ferrous debris helping to keep expensive heat exchangers and ECM circulators running smoothly. **CALEFFI GUARANTEED.**



AIR AND DIRT SEPARATION AND AIR VENTS

This diagram is for illustration purposes only

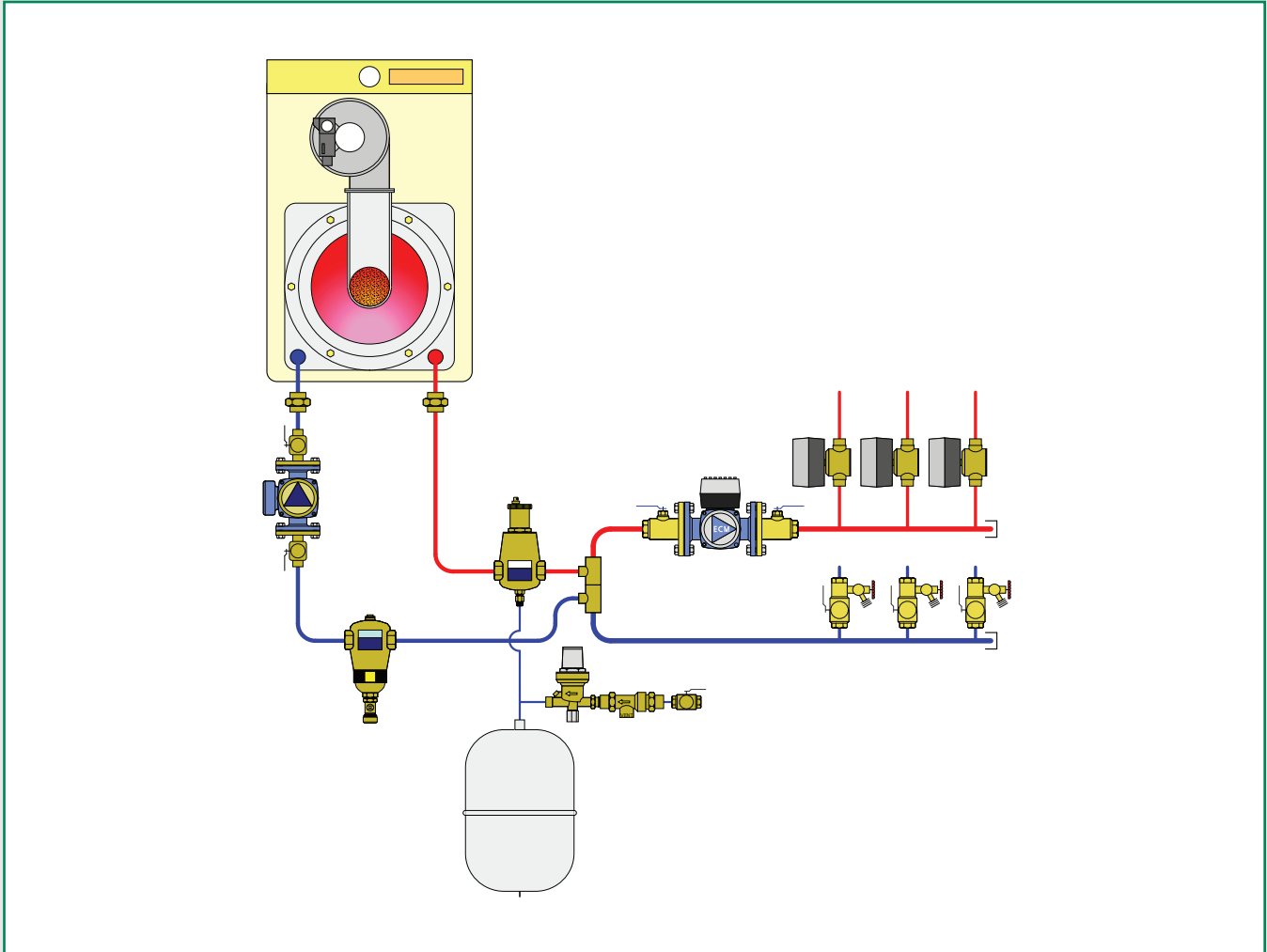

2

PRODUCTS INCLUDED IN SECTION

- Automatic and manual air vents
- Air separators
- Dirt separators
- Air and dirt separators
- Dirt and magnetic dirt separators
- Magnetic dirt separators
- Accessories for air and dirt separators

AUTOMATIC AND MANUAL AIR VENTS

Automatic air vents are designed to remove the air that accumulates in heating and cooling systems without the need for manual intervention. This prevents harmful air that may compromise the life and the performance of the system which includes:

- corrosion due to the oxygen;
- pockets of air trapped in the heat emitters;
- cavitation in the circulation pumps;
- noise from air passing through the pipes.

The accumulation of air bubbles in the air vent body causes the float to drop and thus the vent valve to open. The air vent functions correctly, as long as the water pressure remains below the maximum discharge pressure.

MAXCAL™

Extra high capacity air vent is ideal for use in large piping systems and can also be installed in horizontal piping. The valve body and cover are made of forged brass while the filter, valve stem, float, and spring are all made of stainless steel to prevent the formation of rust.

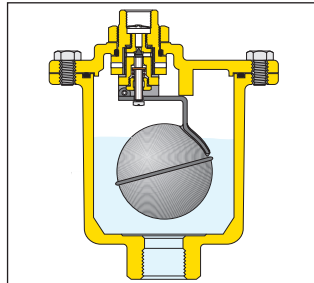

**501
MAXCAL™**

Automatic air vent for heating and air conditioning. Brass body and cover, stainless steel internal components. Extra high discharge capacity.
 Max. working pressure: 230 psi.
 Max. discharge pressure: 90 psi.
 Max. discharge rate: 9 SCFM.
 Working temperature range: -4 – 250°F.
 Discharge top thread: 3/8" female.

Code	Description	Lbs	USD
501502A	3/4" FNPT	7	248.00

MINICAL™ and VALCAL™

These float type automatic air vents are designed to vent released air from the water while being heated. They are used on manifolds or pipes in sealed heating systems.

MINICAL™ is a standard size air vent that will discharge up to 1.75 SCFM.

VALCAL™ is a high capacity larger size air vent that will discharge up to 2.5 SCFM.

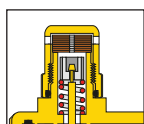
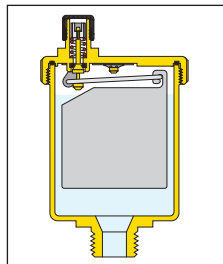

Some MINICAL™ and VALCAL™ models are equipped with a hygroscopic safety cap. Cellulose fiber discs in the cap serve as a redundant seal. Their volume increases by 50% when wet, sealing the discharge vent.

Some MINICAL™ and VALCAL™ models are equipped with a service check valve which facilitates maintenance operations by shutting off the water flow when the air vent is removed and also allows an easy replacement of the air vent without purging the system.

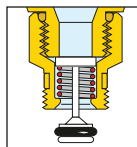

**5020
MINICAL™**

Automatic air vent.
 Brass body.
 Max. working pressure: 150 psi.
 Max. discharge pressure: 32 psi.
 Max. discharge rate: 1.75 SCFM.
 Max. working temperature: 250°F.

Code	Description	Lbs	USD
502015A	1/8" MNPT	0.4	13.90
502040A	1/2" MNPT	0.4	13.90



**5021
MINICAL™**

Automatic air vent with service check valve
 Brass body.
 Max. working pressure: 150 psi.
 Max. discharge pressure: 32 psi.
 Max. discharge rate: 1.75 SCFM.
 Max. working temperature: 230°F.

Code	Description	Lbs	USD
502115A	1/8" MNPT	0.4	18.70
502113A	1/8" MNPT, hygroscopic anti-drip cap	0.4	21.50



**5020
MINICAL™**

Automatic air vent.
 Brass body.
 Hygroscopic safety air vent cap.
 Max. working pressure: 150 psi.
 Max discharge pressure: 32 psi.
 Max. discharge rate: 1.75 SCFM.
 Max. working temperature: 250°F.

Code	Description	Lbs	USD
502043A	1/2" MNPT	0.6	19.60



**5022
VALCAL™**

High discharge automatic air vent.
 Hygroscopic safety air vent cap.
 Max. working pressure: 150 psi.
 Max. discharge pressure: 60 psi.
 Max. discharge rate: 2.5 SCFM.
 Max. working temperature: 250°F.

Code	Description	Lbs	USD
502243A	1/2" MNPT	0.5	33.60



**5023
VALCAL™**

High discharge vent with service check.
 Hygroscopic safety air vent cap.
 Max. working pressure: 150 psi.
 Max. discharge pressure: 60 psi.
 Max. discharge rate: 2.5 SCFM.
 Max. working temperature: 230°F.

Code	Description	Lbs	USD
502343A	1/2" MNPT	0.5	39.70

AUTOMATIC AND MANUAL AIR VENTS



5026 ROBOCAL™

Automatic air vent.
Brass body.
Max. working pressure: 150 psi.
Max. discharge pressure: 90 psi.
Max. discharge rate: 1.75 SCFM.
Max. working temperature: 240°F.

Code	Description	Lbs	USD
502610A	1/8" MNPT	0.6	12.40
502620A	1/4" MNPT	0.6	13.00
502630	3/8" straight thread	1.0	17.30
502640	1/2" straight thread	1.0	18.70



5027 ROBOCAL™

Automatic air vent with service check valve.
Brass body.
Max. working pressure: 150 psi.
Max. discharge pressure: 90 psi.
Max. discharge rate: 1.75 SCFM.
Max. working temperature: 230°F.

Code	Description	Lbs	USD
502710A	1/8" MNPT	0.6	17.20
502720A	1/4" MNPT	0.6	18.20
NA502740A	1/2" MNPT, hygroscopic anti-drip cap	0.6	23.60



Service check valve for removal of air vent or expansion tank without purging system. Fits automatic air vents 502 series.
Max. working pressure: 150 psi.
Max. working temperature: 230°F.

Code	Description	Lbs	USD
59474A	1/8" MNPT x FNPT	0.1	10.20
59804A	1/4" MNPT x FNPT	0.1	10.90
561402A	1/2" MNPT x FNPT	0.2	12.50



551 DISCALAIR®

High discharge automatic air vent.
Brass body.
Stainless steel float guide pin and linkage.
Max. working pressure: 150 psi.
Max. discharge pressure: 150 psi.
Max. discharge rate: 4.5 SCFM.
Max. working temperature: 230°F.

Code	Description	Lbs	USD
551004A	1/2" FNPT and 3/4" MNPT	0.8	80.40



5080 HYGROCAL™

Automatic hygroscopic air vent for hydronic heating system and low pressure steam.
Manual operation by rotating knob.
Chrome plated brass body.
Max. working pressure: 150 psi.
Max. working temperature: 212°F.
Low pressure steam: 15 psi.
(Priced each, sold in package of 25 each)

Code	Description	Lbs	USD
508013A	1/8" MNPT	0.1	6.70

Automatic radiator air vent valve is designed to remove any air trapped inside the heat emitters both during the filling of the system and in normal operation. The automatic air discharge happens when the hygroscopic cellulose fiber discs are dry. As air is vented and water contacts the hygroscopic discs, they increase their volume by 50% which causes the discharge vent to close.

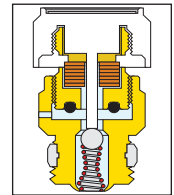

5081

Replacement hygroscopic cartridge fits hygroscopic air vent 5080 series.
(Priced each, sold in package of 25 each)

Code	Description	Lbs	USD
508100A	Cartridge	0.1	5.90



337

Manual air vent with metal seal and adjustable outlet.
Brass body.
Max. working pressure: 150 psi.
Max. working temperature: 212°F.

Code	Description	Lbs	USD
337221A	1/4" MNPT	0.1	8.40

Function
DISCALAIR® automatic air vents release air that forms in the hydraulic circuits of heating and air conditioning systems with pressures to 150 psi. The venting air discharge capacity is capable of expelling over 4 standard cubic feet per minute (SCFM). The circulation of fully de-aerated water or glycol-water mediums enables the equipment to operate under optimum conditions, free from noise, corrosion, localized overheating, or mechanical damage.

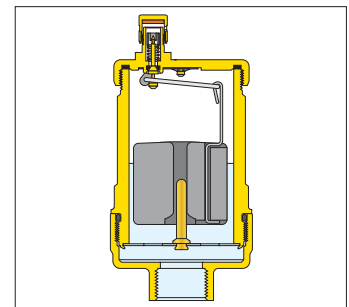

AIR SEPARATORS



551 DISCAL®

Air separator.
Brass body.
Stainless steel float guide pin and linkage.
Glass reinforced nylon internal element.
1/2" NPT female bottom thread.
Max. working pressure: 150 psi.
Working temperature range: 32–250°F.

Code	Description	Lbs	USD
551005A	3/4" FNPT	3.7	172.00
551028A	1" sweat	3.7	177.00
551006A	1" FNPT	3.7	186.00
551066A	1" integral press	3.8	212.00
551035A	1 1/4" sweat	3.7	258.00
551007A	1 1/4" FNPT	4.9	271.00
551067A	1 1/4" integral press	5	326.00
551041A	1 1/2" sweat	4.9	336.00
551008A	1 1/2" FNPT	4.9	353.00
551068A	1 1/2" integral press	5.1	421.00
551054A	2" sweat	5.5	411.00
551009A	2" FNPT	5.5	431.00
551069A	2" integral press	5.5	514.00



551 DISCAL®

Air separator with 1/2" service check valve (code 561402A) to mount expansion tank on bottom thread.
Brass body.
Stainless steel float guide pin and linkage.
Glass reinforced nylon internal element.
Max. working pressure: 150 psi.
Working temperature range: 32–250°F.

Code	Description	Lbs	USD
551005AC	3/4" FNPT	3.8	180.00
551028AC	1" sweat	3.8	184.00
551006AC	1" FNPT	3.8	193.00
551066AC	1" integral press	3.9	217.00
551035AC	1 1/4" sweat	3.8	265.00
551007AC	1 1/4" FNPT	5	277.00
551067AC	1 1/4" integral press	5.1	333.00
551041AC	1 1/2" sweat	5	344.00
551008AC	1 1/2" FNPT	5	360.00
551068AC	1 1/2" integral press	5.2	428.00
551054AC	2" sweat	5.6	417.00
551009AC	2" FNPT	5.6	438.00
551069AC	2" integral press	5.6	521.00

ACCESSORIES



Insulation shell fits DISCAL® 551 series.

Code	Description	Lbs	USD
CBN551005	Fits 3/4" and 1" 551 series	0.1	47.30
CBN551007	Fits 1 1/4" and 1 1/2" 551 series	0.1	50.80
CBN551009	Fits 2" 551 series	0.1	55.50

*Will not fit the 3/4" compact DISCAL®; codes 551003A and 551022A.



Service check valve for easy replacement of expansion tank when connected to bottom of DISCAL®.

Code	Description	Lbs	USD
561402A	1/2" MNPT x 1/2" FNPT	0.2	12.50

Size	MAXIMUM FLOW RATE				
	3/4"	1"	1 1/4"	1 1/2"	2"
GPM	6	10	15	22	39
Cv	19	32	56	73	81

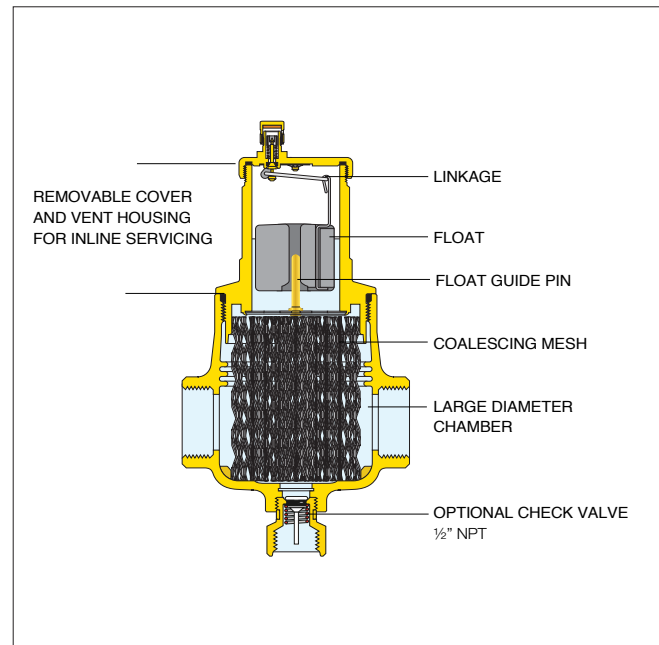

AIR SEPARATORS

5517 DISCAL® Rotating collar



Air separator with rotating collar for horizontal or vertical pipes.
 Brass body.
 Stainless steel float guide pin and linkage.
 Stainless steel mesh internal element.
 Max. working pressure: 150 psi.
 Working temperature range: 32–250°F.

551 DISCAL® Compact



Air separator.
 Brass body.
 Stainless steel float guide pin and linkage.
 Stainless steel mesh internal element.
 ½" NPT bottom thread.
 Max. working pressure: 150 psi.
 Working temperature range: 32–250°F.

Code	Description	Lbs	USD
551705A	3/4" NPT male union	4.9	219.00
551765A	3/4" press union	4.9	231.00
551795A	3/4" sweat union	4.9	216.00
551706A	1" NPT male union	4.9	233.00
551766A	1" press union	4.9	258.00
551796A	1" sweat union	4.9	230.00
551716*	body only, order unions separately	4.4	200.00

*See fitting selection table in Section 8.

Code	Description	Lbs	USD
551003A	¾" FNPT	2.0	115.00
551003AC	¾" FNPT, service check valve	2.1	121.00
551022A	¾" sweat	2.0	111.00
551022AC	¾" sweat, service check valve	2.1	118.00

Construction details DISCAL® compact

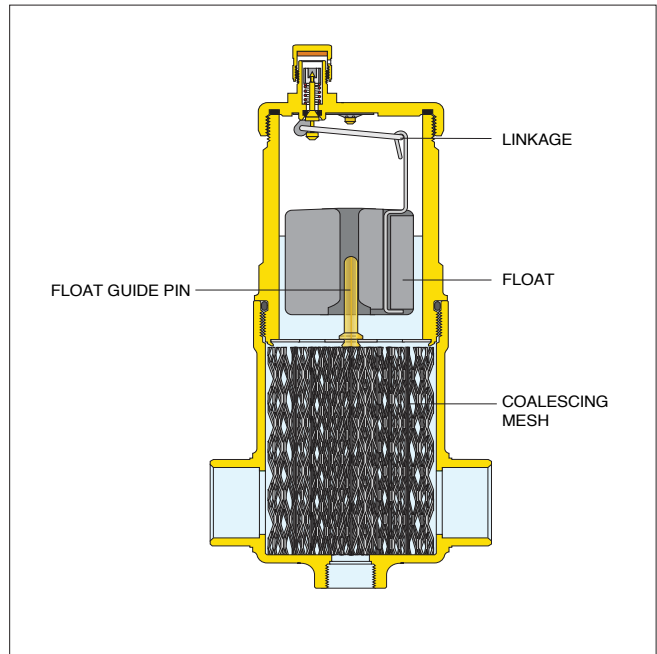

Construction details DISCAL® rotating collar

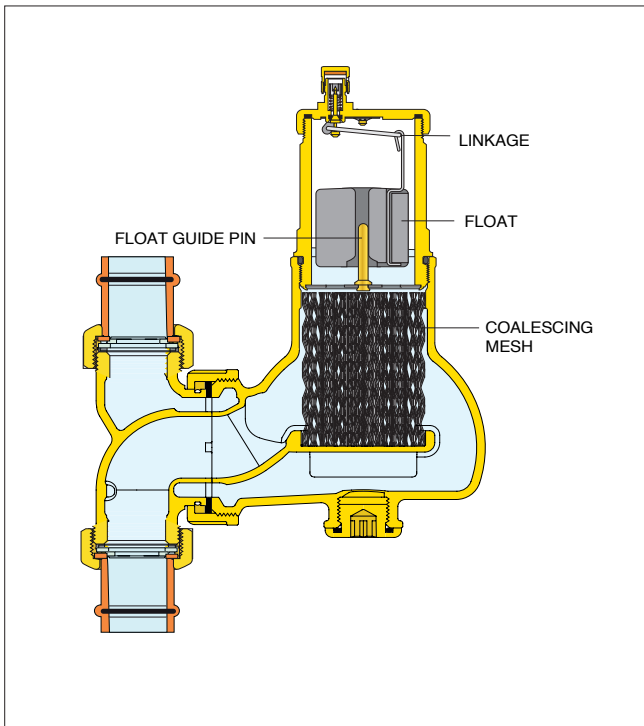

Size	MAXIMUM FLOW RATE		
	¾" compact	¾" vertical	1" vertical
GPM	6	6	10
Cv	12	19	19

Air separation efficiency

DISCAL air separators continuously remove entrained air in hydronic systems with very high separation efficiency. The amount of air removed from a system varies depending on fluid velocity and temperature. As illustrated on the graph, at the 4.0 feet per second fluid velocity, all the air artificially introduced into the system is gradually eliminated during normal system operation by the DISCAL air separator. In conditions where the fluid velocity is slower or the temperature of the fluid is higher, the amount of air separated is even faster.

AIR SEPARATORS



551 DISCAL®

Air separator.
Epoxy resin coated steel body.
Stainless steel float guide pin and linkage.
Stainless steel mesh internal element.
ANSI 150 flange connections.
1" NPT male bottom drain connection.
Complete with male bottom drain valve (NA39753).
½" NPT male side drain connection.
Complete with side drain valve (538402FD).
Max. working pressure: 150 psi.
Vessel temperature range: 32–270°F.



NA551 DISCAL® ASME/CRN

Air separator.
Epoxy resin coated steel body.
Stainless steel float guide pin and linkage.
Stainless steel mesh internal element.
ANSI 150 flange connections.
1" NPT male bottom drain connection.
Complete with drain valve (NA39753).
½" NPT male side drain connection.
Complete with side drain valve (538402FD).
Max. working pressure: 150 psi.
Vessel temperature range: 32–270°F.
ASME and CRN registered.

Code	Description	Lbs	USD
551050A	2" ANSI flange	34	1,872.00
551050AT	2" MNPT	30	1,780.00
551060A	2½" ANSI flange	35	2,001.00
551060AT	2½" MNPT	31	1,909.00
551080A	3" ANSI flange	62	2,649.00
551100A	4" ANSI flange	67	2,963.00
551120A	5" ANSI flange	106	4,313.00
551150A	6" ANSI flange	117	5,557.00

Code	Description	Lbs	USD
NA551050A	2" ANSI flange ASME & CRN	34	2,243.00
NA551060A	2½" ANSI flange ASME & CRN	35	2,398.00
NA551080A	3" ANSI flange ASME & CRN	62	3,174.00
NA551100A	4" ANSI flange ASME & CRN	67	3,552.00
NA551120A	5" ANSI flange ASME & CRN	106	5,167.00
NA551150A	6" ANSI flange ASME & CRN	117	6,659.00

NA prefix indicates ASME tagged and registered with the National Board of Boiler and Pressure Vessel Inspectors; CRN registered.

Air separator construction

DISCAL® air separators are constructed to allow maintenance and cleaning operations to be carried out without having to remove the separator body from the pipe work. All DISCAL® air separator have a bottom connection drain valve. All internal air release control components are fully accessible. The automatic air release valve, located at the top of the separator, has a long chamber for the movement of the float. This feature prevents any debris present in the water from reaching the sealing seat.

Flanged models include a side drain vent to release large amounts of air when filling the system and to remove any debris present above the water level.

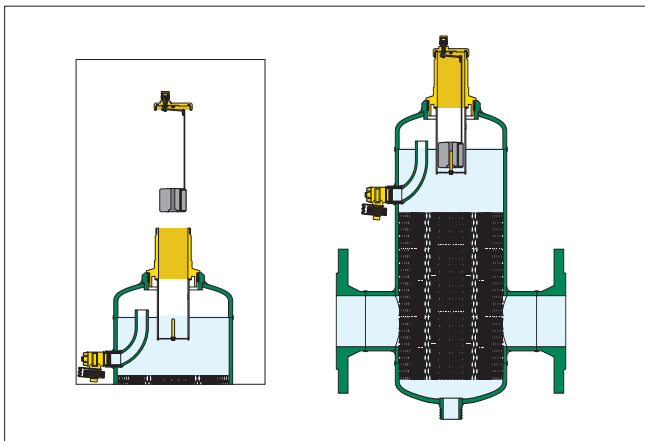

MAXIMUM FLOW RATE										
Size	2"	2½"	3"	4"	5"	6"	8"	10"	12"	
GPM	100	155	220	400	615	880	1,570	2,450	3,525	
Cv	87	174	208	324	520	832	1,109	1,387	1,664	

NA551 DISCAL® ASME



Air separator.
Epoxy resin coated steel body.
Stainless steel float guide pin and linkage.
Stainless steel mesh internal element.
ANSI 150 flange connections.
2" NPT male bottom drain connection.
Complete with drain valve (NA59600).
½" NPT male side drain connection.
Complete with side drain valve (538402FD).
Max. working pressure: 150 psi.
Vessel temperature range: 32–270°F.
ASME and CRN registered.

Code	Description	Lbs	USD
NA551200A	8" ANSI flange ASME & CRN	371	10,897.00
NA551250A	10" ANSI flange ASME & CRN	617	16,344.00
NA551300A	12" ANSI flange ASME & CRN	871	21,248.00

NA prefix indicates ASME tagged and registered with the National Board of Boiler and Pressure Vessel Inspectors; CRN registered.



Replacement drain ball valve.
Fits DISCAL® series.
Brass body.
Lever.
Max. working pressure: 150 psi.
Max. working temperature: 365°F.

Code	Description	Lbs	USD
NA39753	1" FNPT with lever	0.7	35.10
NA59600	2" FNPT with lever	3.5	125.00

DIRT SEPARATORS

The dirt separating action performed by the DIRTCAL® is based on using the internal element with concentric diamond pattern mesh surfaces instead of a mechanical filter. The element offers little resistance to the medium flow while ensuring dirt separation. This occurs due to the particles colliding with the concentric diamond pattern mesh surfaces and then settling to the bottom, and not by filtration; which, over time, gets continuously clogged. By contrast, the DIRTCAL® low-velocity zone dirt separator efficiently removes the particles to as small as 5 µm (0.2 mil) with very low head loss. The dirt collection chamber at the bottom of the DIRTCAL® is at the optimal distance from the inlet and outlet connections to ensure that the collected dirt particles are not affected by the swirling flow through the mesh element. The dirt can then be removed through the bottom drain port even with the system running, by opening the drain valve. Low head losses and performance are maintained over time.



5465 DIRTCAL®

Dirt separator.
Epoxy resin coated steel body.
1" threaded NPT bottom drain connection
Complete with drain valve (code NA39753).
¾" NPT male top thread with brass cap.
ANSI 150 flange connections.
Max. working pressure: 150 psi.
Vessel temperature range: 32–270°F.
Particle separation capacity: to 5 µm (0.2 mil).

Code	Description	Lbs	USD
546550A	2" ANSI flange	29	1,201.00
546560A	2½" ANSI flange	38	1,277.00
546510A	4" ANSI flange	54	1,788.00

Dirt separation comparison

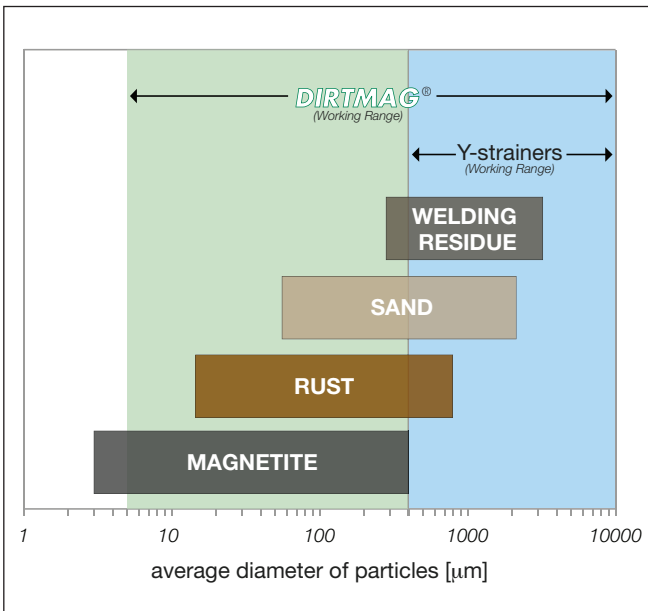

NA5465 DIRTCAL® ASME/CRN



Dirt separator.
Epoxy resin coated steel body.
1" threaded NPT bottom drain connection
Complete with drain valve (code NA39753).
¾" NPT male top thread with brass cap.
ANSI 150 flange connections.
Max. working pressure: 150 psi.
Vessel temperature range: 32–270°F.
Particle separation capacity: to 5 µm (0.2 mil).
ASME and CRN registered.

Code	Description	Lbs	USD
NA546550A	2" ANSI flange ASME & CRN	38	1,925.00
NA546560A	2½" ANSI flange ASME & CRN	38	2,047.00
NA546580A	3" ANSI flange ASME & CRN	55	2,665.00
NA546510A	4" ANSI flange ASME & CRN	55	2,917.00
NA546512A	5" ANSI flange ASME & CRN	138	4,205.00
NA546515A	6" ANSI flange ASME & CRN	148	5,395.00

ASME U-stamp tagged and registered with the National Board of Boiler and Pressure Vessel Inspectors CRN registered.

NA5465 DIRTCAL® ASME/CRN



Dirt separator.
Epoxy resin coated steel body.
2" threaded NPT bottom drain connection.
Complete with drain valve (code NA59600).
¾" NPT male top thread with brass cap.
ANSI 150 flange connections.
Max. working pressure: 150 psi.
Vessel temperature range: 32–270°F.
Particle separation capacity: to 5 µm (0.2 mil).
ASME registered. CRN registered thru 12".
Consult factory for 14".

Code	Description	Lbs	USD
NA546520A	8" ANSI flange ASME & CRN	335	11,030.00
NA546525A	10" ANSI flange ASME & CRN	620	17,004.00
NA546530A	12" ANSI flange ASME & CRN	870	21,060.00
NA546535A	14" ANSI flange ASME	1,000	26,477.00

ASME U-stamp tagged and registered with the National Board of Boiler and Pressure Vessel Inspectors registered. CRN registered, 8" and 10"; consult factory for 12" — 14".

MAXIMUM FLOW RATE						
Size	2"	2½"	3"	4"	5"	6"
GPM	89	150	227	355	816	904
Cv	88	176	211	328	520	842

MAXIMUM FLOW RATE				
Size	8"	10"	12"	14"
GPM	1,570	2,450	3,525	4,800
Cv	1,055	1,400	1,755	2,075

AIR AND DIRT SEPARATORS

The **DISCALDIRT®** air and dirt separator uses a coalescing element that consists of an assembly of concentric diamond pattern mesh surfaces. This element creates the whirling movement required to facilitate the release of micro-bubbles and their adhesion to these surfaces. The bubbles, fusing with each other, increase in volume until the bouyancy force overcomes the adhesion force to the surface. They rise towards the top of the unit and are released through a float-operated automatic air release valve.

The dirt separating action performed by the same element offers little resistance to the medium flow while ensuring dirt separation. The particles collide with the concentric diamond pattern mesh surfaces and then settle to the bottom, and not by filtration unlike mesh strainers; which, over time, get progressively clogged. By contrast, the DISCALDIRT®'s low-velocity zone dirt separator function efficiently removes the particles to as small as 5µm (0.2 mil) with very low head loss. The dirt can then be removed through the bottom drain port.



546 DISCALDIRT®

Air & Dirt separator.
 Brass body.
 Stainless steel float guide pin and linkage.
 Glass reinforced nylon internal element.
 Max. working pressure: 150 psi.
 Working temperature range: 32 – 250°F.
 Particle separation capacity: to 5 µm (0.2 mil).

Code	Description	Lbs	USD
546096A	1" sweat	8.3	293.00
546016A	1" MNPT	8.3	307.00
546097A	1¼" sweat	8.3	349.00

The **DISCALDIRTMAG™** air and dirt separator with magnet uses an external magnet ring for separation of ferrous impurities. The external magnet allows greater effectiveness in the separation and collection of ferrous impurities. The impurities are retained in the body of the dirt separator by the strong magnetic field created by magnets in its external outer ring. The outer ring is removable from the body to allow the flushing of sludge, with the system still running. Since the magnetic ring is positioned outside the body of the dirt separator, it does not interfere with the flow through the device.



5461 DISCALDIRTMAG™

Air & Dirt separator with magnet.
 Brass body.
 Stainless steel float guide pin and linkage.
 Glass reinforced nylon internal element.
 Max. working pressure: 150 psi.
 Working temperature range: 32 – 250°F.
 Particle separation capacity: to 5 µm (0.2 mil).
 Ferrous impurities separation efficiency: 100%.



Code	Description	Lbs	USD
546196A	1" sweat	8.5	367.00
546166A	1" press	NEW 8.5	393.00
546116A	1" MNPT	8.5	384.00
546197A	1¼" sweat	8.5	438.00
546167A	1¼" press	NEW 8.5	495.00



5461 DISCALDIRTMAG™

Air & Dirt separator with magnet.
 Epoxy resin coated steel body.
 Stainless steel float guide pin and linkage.
 Stainless steel mesh internal element.
 Complete with union connections.
 Max. working pressure: 150 psi.
 Working temperature range: 32 – 230°F.
 Particle separation capacity: to 5 µm (0.2 mil).
 Ferrous impurities separation efficiency: 100%.

Code	Description	Lbs	USD
546198A	1½" sweat union	22	1,083.00
546108A	1½" NPT female union	22	1,116.00
546168A	1½" press union	22	1,237.00
546199A	2" sweat union	23	1,135.00
546109A	2" NPT female union	23	1,178.00
546169A	2" press union	23	1,380.00



Insulation shell for DISCALDIRT® & DISCALDIRTMAG™.

Code	Description	Lbs	USD
CBN546002	Fits 1", 1¼" brass 546 only	0.1	74.20
CBN546118	Fits 1½" steel 5461 only	0.1	93.80
CBN546119	Fits 2" steel 5461 only	0.1	107.00

Size	MAXIMUM FLOW RATE			
	1"	1¼"	1½"	2"
GPM	10	15	22	39
Cv	32	40	50	79

546 DISCALDIRT®

Air & Dirt separator.
 Epoxy resin coated steel body.
 Stainless steel float guide pin and linkage.
 Stainless steel mesh internal element.
 1" NPT threaded bottom drain connection.
 Complete with side drain valve (538402 FD).
 ANSI 150 flange connections.
 Complete with drain valve (NA39753)
 Max. working pressure: 150 psi.
 Vessel temperature range: 32 – 270°F.
 Particle separation capacity: to 5 µm (0.2 mil).



Code	Description	Lbs	USD
546050A	2" ANSI flange	40	2,377.00
546060A	2½" ANSI flange	42	2,505.00
546080A	3" ANSI flange	73	3,226.00
546100A	4" ANSI flange	78	3,537.00
546120A	5" ANSI flange	181	5,103.00

AIR AND DIRT SEPARATORS

NA546
DISCALDIRT®
ASME/CRN



Air & Dirt separator.
Epoxy resin coated steel body.
Stainless steel float guide pin and linkage.
Stainless steel mesh internal element.
1" (2–6" sizes) and 2" (8–14" sizes)
threaded NPT bottom drain connection.
ANSI 150 flange connections.
Complete with drain valve NA39753
(2–6" sizes), NA59600 (8–14" sizes).
Max. working pressure: 150 psi.
Vessel temperature range: 32–270°F.
ASME registered. CRN registered thru 12".
Consult factory for 14".

Code	Description	Lbs	USD
NA546050T	2" Threaded ASME & CRN	28	2,276.00
NA546060A	2½" ANSI flange ASME & CRN	42	3,062.00
NA546080A	3" ANSI flange ASME & CRN	73	3,943.00
NA546100A	4" ANSI flange ASME & CRN	78	4,323.00
NA546120A	5" ANSI flange ASME & CRN	181	6,236.00
NA546150A	6" ANSI flange ASME & CRN	188	7,608.00
NA546200A	8" ANSI flange ASME & CRN	355	14,132.00
NA546250A	10" ANSI flange ASME & CRN	555	21,729.00
NA546300A	12" ANSI flange ASME & CRN	825	27,172.00
NA546350A	14" ANSI flange ASME	950	34,358.00

ASME U-stamp tagged and registered with the National Board of Boiler and Pressure Vessel Inspectors; CRN registered, 2" – 12"; consult factory for 14".

Low head losses and high performance are maintained over time. The dirt separating action performed by the DISCALDIRT® air and dirt separator is based on using the internal element with concentric diamond pattern mesh surfaces instead of an ordinary filter. The element offers little resistance to the medium flow while ensuring dirt separation. This occurs due to the particles colliding with the concentric diamond pattern mesh surfaces and then settling to the bottom, and not by filtration; which, over time, gets progressively clogged. By contrast, the DISCALDIRT® low-velocity zone air and dirt separator efficiently removes the particles to as small as 5 µm (0.2 mil) with very low head loss. The dirt collection chamber at the bottom of the DISCALDIRT® is at the right distance from the inlet and outlet connections so that the collected dirt particles are not affected by the swirling flow through the bottom drain port, even with the system running, by opening the drain valve with the handle.

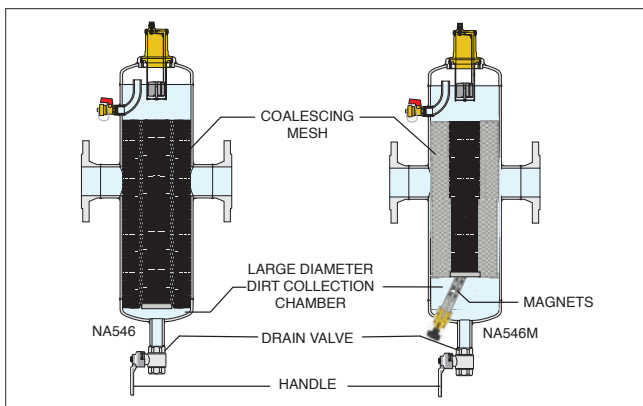

NA546M
DISCALDIRTMAG™
ASME/CRN



Air & Dirt separator with magnets.
Epoxy resin coated steel body.
Stainless steel float guide pin and linkage.
Stainless steel mesh internal element.
ANSI 150 flange connections.
1" (2–6" sizes) and 2" (8–14" sizes)
threaded NPT bottom drain connection.
Complete with drain valve NA39753
(2–6" sizes), NA59600 (8–14" sizes).
Max. working pressure: 150 psi.
Vessel temperature range: 32–270°F.
Particle separation capacity: to 5 µm (0.2 mil).
Ferrous impurities separation efficiency: up to 100%.
ASME registered. CRN registered thru 12".
Consult factory for 14".

Code	Description	Lbs	USD
NA546050TM*	2" Threaded ASME & CRN	31	2,631.00
NA546060AM*	2½" ANSI flange ASME & CRN	45	3,440.00
NA546080AM*	3" ANSI flange ASME & CRN	76	4,476.00
NA546100AM*	4" ANSI flange ASME & CRN	81	4,866.00
NA546120AM*	5" ANSI flange ASME & CRN	184	6,836.00
NA546150AM*	6" ANSI flange ASME & CRN	191	8,249.00
NA546200AM**	8" ANSI flange ASME & CRN	365	16,183.00
NA546250AM**	10" ANSI flange ASME & CRN	565	23,365.00
NA546300AM**	12" ANSI flange ASME & CRN	835	29,607.00
NA546350AM**	14" ANSI flange ASME	960	37,004.00

*With one magnet

**With three magnets

ASME U-stamp tagged and registered with the National Board of Boiler and Pressure Vessel Inspectors. CRN registered, 2" – 12"; consult factory for 14".



In the DISCALDIRTMAG™ air and dirt separator with magnets ferrous impurities are captured by a concentrated magnetic field created by a stack of neodymium rare-earth magnets positioned inside a brass dry-well which is below the flow stream. Non-magnetic dirt particles are separated by colliding with an internal element in the flow stream and settling to the bottom. The deep collection chamber keeps the dirt from re-entering the flow stream. The dirt and ferrous impurities are flushed out while the system is operating, by removing the magnets and opening the purge valve.

	MAXIMUM FLOW RATE									
	2"	2½"	3"	4"	5"	6"	8"	10"	12"	14"
GPM	100	155	220	400	615	880	1,570	2,450	3,525	4,800
Cv	87	174	208	324	520	832	1,109	1,387	1,664	1,967

DIRT & MAGNETIC DIRT SEPARATORS

The dirt separating action performed by the DIRTCAL® is based on using the internal element with concentric diamond pattern mesh surfaces instead of a mechanical filter. The element offers little resistance to the medium flow while ensuring dirt separation. This occurs due to the particles colliding with the concentric diamond pattern mesh surfaces and then settling to the bottom, and not by filtration; which, over time, gets continuously clogged. By contrast, the DIRTCAL® low-velocity zone dirt separator requires a pressure drop 25% or less than that of a comparable Y-strainer depending on mesh size and amount of filtered debris. It efficiently removes the particles to as small as 5 µm (0.2 mil) with very low head loss. The dirt collection chamber at the bottom of the DIRTCAL® is at the optimal distance from the inlet and outlet connections to ensure that the collected dirt particles are not affected by the swirling flow through the mesh element. The dirt can then be removed through the bottom drain port even with the system running by opening the drain valve. Low head losses and performance are maintained over time.

The versatile DIRTMAG® magnetic dirt separator removes both magnetic and non-magnetic particles continuously. In addition to removing sand and rust impurities with a glass-reinforced nylon internal element in a low-velocity zone chamber, the DIRTMAG® features a powerful removable external magnet around the body below the flow line for fast and effective capture of ferrous particles. The DIRTMAG® has the magnet positioned externally to maintain low pressure loss, and removes up to 100% of the ferrous impurities that can form in a hydronic system.

The DIRTMAG® can be fitted with optional insulated covers, code CBN5462xx series purchased separately, to minimize heat loss.



5463 DIRTMAG®

Dirt separator with magnet.
 Brass body.
 ½" NPT top thread with plug.
 Max. working pressure: 150 psi.
 Working temperature range: 32–250°F.
 Particle separation capacity: to 5 µm (0.2 mil).
 Ferrous impurities separation efficiency: 100%.



Code	Description	Lbs	USD
546305A	¾" FNPT	4.2	195.00
546328A	1" sweat	4.2	199.00
546306A	1" FNPT	4.2	209.00
546366A	1" press	4.5	227.00
546335A	1¼" sweat	4.2	290.00
546307A	1¼" FNPT	5.3	305.00
546367A	1¼" press	5.6	348.00
546341A	1½" sweat	4.9	378.00
546308A	1½" FNPT	6.2	398.00
546368A	1½" press	6.5	454.00
546354A	2" sweat	5.5	462.00
546309A	2" FNPT	6.2	479.00
546369A	2" press	6.5	554.00

MAXIMUM FLOW RATE					
Size	¾"	1"	1¼"	1½"	2"
GPM	6	9	15	24	36
l/s	0.4	0.57	1.0	1.5	2.3
Cv	19	32	56	73	81



Replacement drain valve fits DIRTCAL® 5462 series, DIRTMAG® 5463 series, DISCALDIRT® 546 series and DISCALDIRTMAG™ 5461 series.
 Brass body.
 Max. working pressure: 150 psi.
 Max. working temperature: 250°F.

Code	Description	Lbs	USD
538402 FD	½" MNPT x ¾" GHT	0.3	12.50

Application diagram

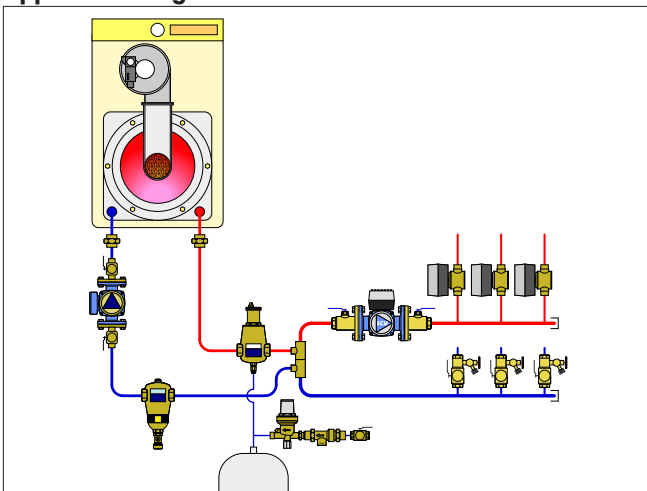

DIRTCAL® to DIRTMAG®
 Retrofit kit for ¾" to 2" 5462 brass DIRTCAL.

Code	Description	Lbs	USD
F41661A	Retrofit kit	2.0	96.70



Insulation shell fits DIRTMAG® 5463 series.
 Labels included for field installation to externally identify product use.

Code	Description	Lbs	USD
CBN546205	Fits ¾" & 1" DIRTCAL®, DIRTMAG®	0.1	47.30
CBN546207	Fits 1¼" & 1½" DIRTCAL®, DIRTMAG®	0.1	50.80
CBN546209	Fits 2" DIRTCAL®, DIRTMAG®	0.1	55.50

MAGNETIC DIRT SEPARATORS



5463 DIRTMAG® PRO

Dirt separator with dual magnets. Internal magnet in drywell. External clip-on magnet. Brass body. Max. working pressure: 150 psi. Working temperature range: 32-230°F. Particle separation capacity: to 5um (0.2 mil). Ferrous impurities separation efficiency: 100%.



NA5453 DIRTMAG®

Dirt separator with magnet. Brass mounting housing. Composite PA66G30 body. Max. working pressure: 45 psi. Working temperature range: 32 – 195°F. Particle separation capacity: to 5 µm (0.2 mil). Ferrous impurities separation efficiency: 100%. Drain valve with hose connection. Top dosing point port. Dosing capacity: 12 fluid oz. Manual screw air vent.

Code	Description	Lbs	USD
546328AM	1" sweat	4.7	219.00
546306AM	1" FNPT	4.7	230.00
546366AM	1" press	5	250.00
546335AM	1¼" sweat	4.7	319.00
546307AM	1¼" FNPT	5.8	335.00
546367AM	1¼" press	6.1	383.00
546341AM	1½" sweat	5.4	416.00
546308AM	1½" FNPT	6.7	438.00
546368AM	1½" press	7	499.00
546354AM	2" sweat	6	508.00
546309AM	2" FNPT	6.7	527.00
546369AM	2" press	7	609.00

Code	Description	Lbs	USD
NA545305	¾" NPT male union	4.5	171.00
NA545365	¾" press union	4.5	186.00
NA545395	¾" sweat union	4.5	170.00
NA545306	1" NPT male union	4.5	198.00
NA545366	1" press union	4.7	223.00
NA545396	1" sweat union	4.5	189.00
NA545355	¾" NPT female union, isolation valves	5.5	206.00
NA545356	1" NPT female union, isolation valves	5.5	240.00
NA545376	1" press union, isolation valves	5.5	328.00

MAXIMUM FLOW RATE

Size	¾"	1"
GPM	10	10
Cv w/ ball valve	9	9
Cv w/o ball valve	12	12

The DIRTMAG® PRO series extends the popular Caleffi dirt separator family by adding a powerful neodymium magnetic stack inside a drywell inserted into the top of the body within the flow stream. Additional magnetic flux increases the speed of magnetite removal from the hydronic fluid for maximum protection.

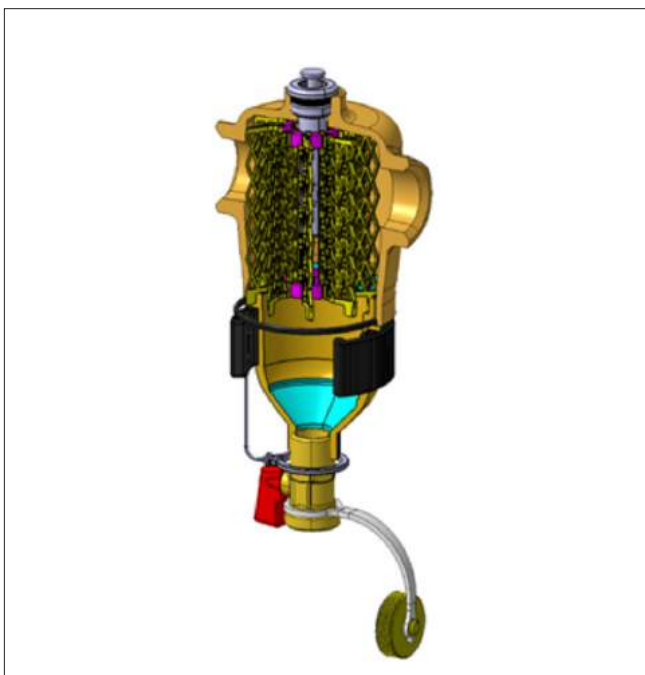

The dirt separator with magnet combines the action of the internal element and magnet. The impurities in the water strike the internal element and are separated, dropping into the bottom of the body where they are collected. Ferrous impurities are also trapped inside the dirt separator body by two strong magnets inserted into removable outer ring collar. The collected impurities are discharged by removing the external ring magnet and opening the drain valve. This procedure can be performed while the system is in operation.



The special coupling between the locking nut and the mounting base allows the DIRTMAG® dirt separator to be rotated for installation to either vertical or horizontal pipes, while maintaining the same operating performance.

MAGNETIC DIRT SEPARATORS

Ferrous and non ferrous impurities in hydronic systems can deposit onto heat exchanger surfaces and accumulate in pump cavities causing reduced thermal efficiency and premature wear. The small and often microscopic magnetic particles, called magnetite, form when iron or steel corrodes. Highly abrasive, the extremely fine particles are difficult to remove by traditional means. DIRTMAG® separators offer highly efficient separation of typical dirt as well as magnetite. The magnetite is captured by a concentrated magnetic field created by a stack of neodymium rare-earth magnets positioned inside a brass dry-well which is below the flow stream. Non-magnetic dirt particles are separated by colliding with an internal element in the flow stream, settling to the bottom. The deep collection chamber keeps the dirt from re-entering the flow stream.



To purge the debris, the flexible magnetic stack is removed from the brass dry-well and, even while the system is still running, the drain valve is opened. Aided by the system pressure, the dirt and magnetite flushes out quickly and effectively. DIRTMAG® magnetic dirt separators accomplish 2½ times the ferrous impurities removal performance of standard dirt separators, delivering up to 100% elimination efficiency.



MAXIMUM FLOW RATE						
Size	2"	2½"	3"	4"	5"	6"
GPM	89	150	227	355	816	904
Cv	88	176	211	328	520	842

MAXIMUM FLOW RATE				
Size	8"	10"	12"	14"
GPM	1,570	2,450	3,525	4,800
Cv	1,055	1,400	1,755	2,075



**5465M
DIRTMAG®**

Magnetic dirt separator with one magnet assembly.
Epoxy resin coated steel body.
Complete with drain valve (code NA39753).
¾" NPT male top thread with brass cap.
ANSI 150 flange connections.
Max. working pressure: 150 psi.
Vessel temperature range: 32–270°F.
Particle separation capacity: to 5 µm (0.2 mil).
Ferrous impurities separation efficiency: 100%.

Code	Description	Lbs	USD
546550AM	2" ANSI flange	41	1,550.00
546560AM	2½" ANSI flange	41	1,669.00
546580AM	3" ANSI flange	58	2,256.00
546510AM	4" ANSI flange	58	2,495.00



**NA5465M
DIRTMAG® ASME/CRN**

Magnetic dirt separator with one magnet assembly.
Epoxy resin coated steel body.
Complete with drain valve (code NA39753).
¾" NPT male top thread with brass cap.
ANSI 150 flange connections.
Max. working pressure: 150 psi.
Vessel temperature range: 32–270°F.
Particle separation capacity: to 5 µm (0.2 mil).
Ferrous impurities separation efficiency: 100%.
ASME and CRN registered.

Code	Description	Lbs	USD
NA546550AM	2" ANSI flange ASME & CRN	41	2,199.00
NA546560AM	2½" ANSI flange ASME & CRN	41	2,322.00
NA546580AM	3" ANSI flange ASME & CRN	58	3,062.00
NA546510AM	4" ANSI flange ASME & CRN	58	3,314.00
NA546512AM	5" ANSI flange ASME & CRN	141	4,603.00
NA546515AM	6" ANSI flange ASME & CRN	151	5,792.00



**NA5465M
DIRTMAG® ASME/CRN**

Magnetic dirt separator with three magnets assembly.
Epoxy resin coated steel body.
Complete with drain valve (code NA59600).
¾" NPT male top thread with brass cap.
ANSI 150 flange connections.
Max. working pressure: 150 psi.
Vessel temperature range: 32–270°F.
Particle separation capacity: to 5 µm (0.2 mil).
Ferrous impurities separation efficiency: 100%.
ASME registered. CRN registered thru 12".
Consult factory for 14".

Code	Description	Lbs	USD
NA546520AM	8" ANSI flange ASME & CRN	345	12,588.00
NA546525AM	10" ANSI flange ASME & CRN	630	18,562.00
NA546530AM	12" ANSI flange ASME & CRN	880	22,617.00
NA546535AM	14" ANSI flange ASME	1,010	28,035.00

ACCESSORIES FOR AIR AND DIRT SEPARATORS



Hygroscopic air vent cap fits DISCAL® 551, and DISCALDIRT® 546 series, and MINICAL™ 502 series.

Code	Description	Lbs	USD
R59681	Vent cap	0.1	15.50



Anti-suction air vent cap fits DISCAL® 551, DISCALDIRT® 546 series and MINICAL™ 502 series.

Code	Description	Lbs	USD
562100	Vent cap	0.1	16.30



Replacement air vent cap fits DISCAL® 551 and DISCALDIRT® 546 series.

Code	Description	Lbs	USD
R59119	Vent cap	0.1	10.30



Replacement plastic cap fits MINICAL™ 5020 and 5021 series.

Code	Description	Lbs	USD
R56214	Vent cap	0.1	1.70



Replacement plastic air vent cap fits 5026 and 5027 series.

Code	Description	Lbs	USD
R56142	Vent cap	0.1	1.60



Magnetic/drywell assembly for DISCALDIRTMAG™ and DIRTMAG®.

Code	Description	Lbs	USD
49684A	Fit 2" and 2½"	3.0	267.00
49685A	Fit 3" to 6"	3.0	386.00
F0000349	Fit 8" to 14"	3.0	504.00



Replacement air vent assembly fits DISCAL® brass 551 series (except Compact and Rotating Collar version), brass 546, brass and steel 5461 series and SEP4™ 5495 series.

Code	Description	Lbs	USD
59829	Air vent assembly for brass DISCAL®	2.0	100.00



Replacement air vent assembly fits steel 551, NA551 steel DISCAL® and 546 steel series DISCALDIRT® and DISCALDIRTMAG™.

Code	Description	Lbs	USD
59756	Air vent assembly for steel DISCAL®	3.0	117.00



Replacement cover and float subassembly. Vent cap sold separately.

Code	Description	Lbs	USD
F39807	Cover and float for brass DISCAL®	0.4	48.80
F0001470	Cover and float for steel DISCAL®	0.5	61.50



Drain ball valve. Fits DIRTCAL® 5465 and NA5465 series. Fits steel separators in section 2. Brass body. Lever. Max. working pressure: 150 psi. Max. working temperature: 365°F.

Code	Description	Lbs	USD
NA39753	1" FNPT with lever	0.7	35.10
NA59600	2" FNPT with lever	3.5	125.00



Vent cap adapter fits all air separators and air vents except 5026 and 5027 series.

Code	Description	Lbs	USD
NA10204	¼" MNPT	0.1	17.60



Replacement coalescing element for brass separators (except 551 Compact and 5517 Rotating collar).

Code	Description	Lbs	USD
F0001179	For sizes ¾" to 1¼" (sweat)	0.2	16.30
F59917	For sizes 1¼" (NPT, press) to 2"	0.2	16.30

DIGITAL JOURNAL EXCELLENCE IN EDUCATION



idronics



idronics™ is a complimentary educational journal series for hydronic, plumbing and renewable energy professionals to aid them in system design, component application and selection. The popular and frequently referenced publication is written by engineers and oriented towards innovative design techniques with a commitment to continuous education of North American professionals. Beginning with the 27th edition, and in cadence with edition releases, Caleffi will now provide digital access to the journal. Watch for the collection to GROW! **CALEFFI GUARANTEED.**

Digital idronics™
idronics.caleffi.com

For more information
marketingadmin@caleffi.com

THERMOSTATIC RADIATOR VALVES

This diagram is for illustration purposes only

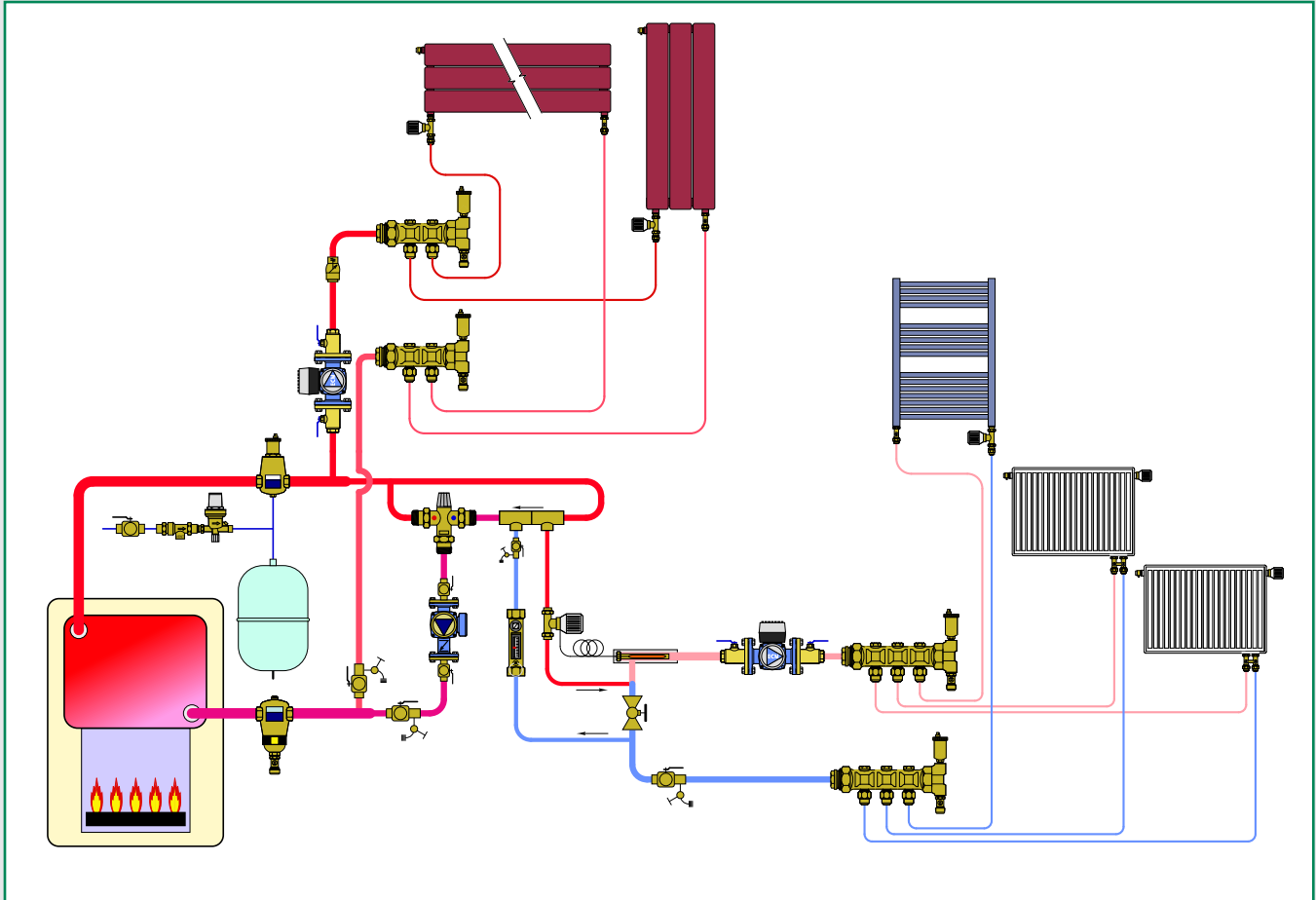

PRODUCTS INCLUDED IN SECTION

- Thermostatic control heads
- Accessories for thermostatic control heads
- Thermo-electric actuators
- NPT thermostatic radiator valve bodies
- European style towel warmer radiator valves
- Connection valves for panel radiators
- Connection fittings

THERMOSTATIC CONTROL HEADS



200

Thermostatic control head fits radiator valves. Set point locking mechanism. Range stop adjustment. Built-in sensor with liquid-filled element. Fits valve 220, 221, 338 and 339 series. Graduated scale from * to 5 corresponding to a temperature scale adjustment range of 45–82°F (7–28°C).

Code	Description	Lbs	USD
200000	Built-in sensor	0.5	48.10



472

Thermostatic control head with remote adjusting knob, liquid-filled element. Fits valves 220, 221, 338, 339 & 676 series (direct coupling). Temperature range: 43–82°F (6–28°C). Capillary length: 78 in. (2 m).

Code	Description	Lbs	USD
472000	Remote wall sensor	1	164.00



201

Thermostatic control head fits radiator valves. With remote sensor. Fits valve 220, 221, 338 and 339 series. Graduated scale from * to 5 corresponding to a temperature scale adjustment range of 45–82°F (7–28°C). Capillary length: 78" (2 m).

Code	Description	Lbs	USD
201000	Remote sensor	1	86.00



203

Thermostatic control head fits radiator valves; with contact probe. Built-in sensor with liquid-filled element. Fits valve 220, 221, 338 and 339 series. The pre-set scale corresponds to adjustment temperature range of 68–122°F (20–50°C). Capillary length: 78" (2 m).

Code	Description	Lbs	USD
203502	Remote sensor probe	0.5	163.00

ACCESSORIES



4490

Manual knob for thermostatic radiator valves. Fits valves 220 and 221 series.

Code	Description	Lbs	USD
449010	Manual knob	0.1	10.00

THERMO-ELECTRIC ACTUATOR



6564

Thermo-electric actuator for electric control of radiator valves. Fits valves 220, 221, 338 and 339 series. Low current draw. Power supply: 24 V AC/DC. Initial current draw: ≤ 250 mA. Power consumption: 3 W, 6 VA. 31.5" wire lead connection.

Code	Description	Lbs	USD
656404	24 V AC/DC	0.4	66.30
656414	24 V AC/DC with microswitch	0.4	83.70

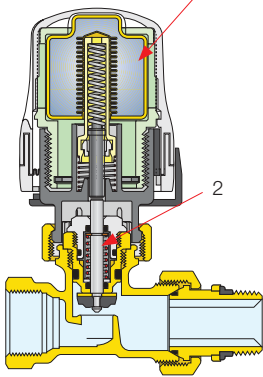

Key features

The thermostatic control head is filled with a non compressible liquid bellows (1). Plus, the radiator valve body has an extra strong valve stem compression spring (2). The non compressible liquid provides the force required to compress the strong valve stem spring. When the temperature decreases, the liquid bellows contracts, which allows the valve stem spring to lift the valve plug from valve seat after long periods of non-movement. This ensures that after a long 'off-season', when the actuator operates for the first time, the spring reliably lifts the valve plug off the seat without sticking. In addition, the 200000 control head features an easy-to-use locking mechanism that prevents unauthorized temperature set point changes and a range stop adjustment that limits the maximum temperature setting to save energy and over-heating.

Function

The control mechanism of the thermostatic radiator valve is a proportional temperature controller, composed of a liquid filled bellows. With increasing temperature the liquid expands which, in turn, causes the bellows to expand. When the temperature decreases the opposite occurs; the bellows contracts allowing the spring to return it to the original position. By connection to the valve stem, these movements adjust the heat transfer medium to the radiator.

*Head shown vertical for illustration only, it should be installed horizontally.

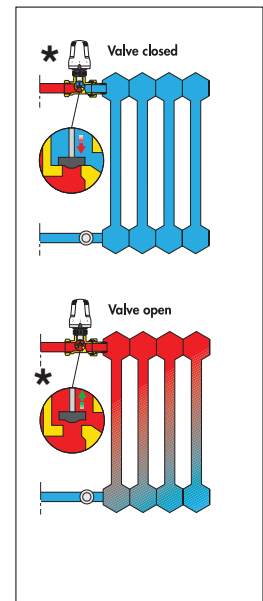

NPT THERMOSTATIC RADIATOR VALVE BODIES



220

Angled radiator valve body. Order thermo-electric actuators or thermostatic control heads separately for field installation.
Chrome plated.
Max. working pressure: 150 psi (10 bar).
Temperature range: 40–212°F (5–100°C).

Code	Description	Cv	Lbs	USD
220400A	½" FNPT in, ½" NPT male union out	2.7	0.3	47.20
220500A	¾" FNPT in, ¾" NPT male union out	3.7	0.3	51.70



221

Straight radiator valve body. Order thermo-electric actuators or thermostatic control heads separately for field installation.
Chrome plated.
Max. working pressure: 150 psi (10 bar).
Temperature range: 40–212°F (5–100°C).

Code	Description	Cv	Lbs	USD
221400A	½" FNPT in, ½" NPT male union out	1.7	0.3	47.20
221500A	¾" FNPT in, ¾" NPT male union out	2.5	0.3	51.70



Replacement internal valve assembly fits radiator valves.

Code	Description	Lbs	USD
F36073	½" and ¾"	0.1	6.60



Universal radiator tool for installing ½ and ¾" tail pieces.

Code	Description	Lbs	USD
387127	Radiator tool	1.0	69.20

EUROPEAN STYLE TOWEL WARMER RADIATOR VALVES



338

Angled radiator valve body. Convertible from standard manual operation to automatic control with thermostatic control heads.
Chrome plated.
Fits copper, single and multilayer PEX pipes.
Max. working pressure: 150 psi (10 bar).
Temperature range: 40–212°F (5–100°C).

Code	Radiator Connection	Pipe Connection	Cv	Lbs	USD
338452	½" straight	¾" conical	3.1	0.5	49.70



342

Angled isolation and balancing valve. Chrome plated.
Fits copper, single and multilayer PEX pipes.
Max. working pressure: 150 psi (10 bar).
Temperature range: 40–212°F (5–100°C).

Code	Radiator Connection	Pipe Connection	Cv	Lbs	USD
342452	½" straight	¾" conical	4.6	0.5	32.70



339

Straight radiator valve body. Convertible from standard manual operation to automatic control with thermostatic control heads.
Chrome plated.
Fits copper, single and multilayer PEX pipes.
Max. working pressure: 150 psi (10 bar).
Temperature range: 40–212°F (5–100°C).

Code	Radiator Connection	Pipe Connection	Cv	Lbs	USD
339452	½" straight	¾" conical	2.0	0.5	53.60



343

Straight isolation and balancing valve. Chrome plated.
Fits copper, single and multilayer PEX pipes.
Max. working pressure: 150 psi (10 bar).
Temperature range: 40–212°F (5–100°C).

Code	Radiator Connection	Pipe Connection	Cv	Lbs	USD
343452	½" straight	¾" conical	2.5	0.5	34.30

Intended for use in metric radiators such as European towel warmers and panel radiators.

CONNECTION VALVES FOR PANEL RADIATORS

Caleffi panel radiator valves are designed to be connected to the bottom of panel radiators. They come in two versions: for two-pipe and one-pipe systems. Both are available straight (pipes exiting the floor) and angled (pipes exiting the wall). The two-pipe version is equipped with two ball shut-off valves. The one-pipe, in addition to the shut-off valves, is equipped with an adjustable by-pass from 30% to 50% of the flow rate towards the radiator, and a flow check valve device (1) prevents thermo-syphoning upward into radiator from by-passing flow.

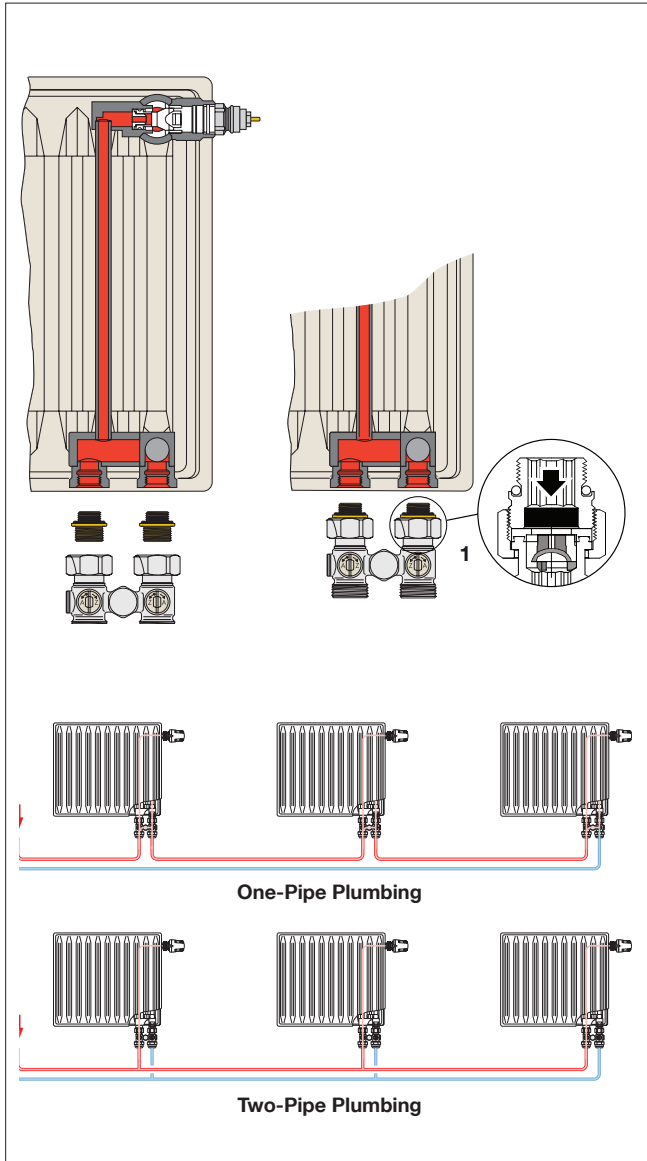

3010

Valve for panel radiators that have built-in thermostatic valve unit.
Two-pipe straight version (floor connections) fits 1/2" female radiator connections.
Max. working pressure: 150 psi (10 bar).
Max. working temperature: 212°F (100°C).

Code	Radiator Connection	Pipe Connection	Lbs	USD
301040	1/2" straight	3/4" conical	1	39.80



3011

Valve for panel radiators that have built-in thermostatic valve unit.
Two-pipe valve angled version (wall connections) fits 1/2" female radiator connections.
Max. working pressure: 150 psi (10 bar).
Max. working temperature: 212°F (100°C).

Code	Radiator Connection	Pipe Connection	Lbs	USD
301140	1/2" straight	3/4" conical	1	39.80



3012

Valve for panel radiators that have built-in thermostatic valve unit.
One-pipe straight version (floor connections) fits 1/2" female radiator connections.
With adjustable by-pass.
Balance knob.
Max. working pressure: 150 psi (10 bar).
Max. working temperature: 212°F (100°C).

Code	Radiator Connection	Pipe Connection	Lbs	USD
301241	1/2" straight	3/4" conical	1	69.70



3013

Valve for panel radiators that have built-in thermostatic valve unit.
One-pipe angled version (wall connections) fits 1/2" female radiator connections.
With adjustable by-pass.
Balance knob.
Max. working pressure: 150 psi (10 bar).
Max. working temperature: 212°F (100°C).

Code	Radiator Connection	Pipe Connection	Lbs	USD
301341	1/2" straight	3/4" conical	1	69.70



4497

Wall-covering plate.
Fits dual panel radiator valves 301.
With wall connections.
In white ABS.
Outlet center distance: 40–50 mm.

Code	Description	Lbs	USD
449740	Plate	0.1	3.50

CONNECTION FITTINGS



**681
Universal
PEX fittings**

681 series fittings are compatible with any ASTM F876 single layer PEX.
Max. working pressure: 150 psi.
Working temperature for ASTM F876 PEX piping: 41 – 180°F.
Chrome plated nut.

Code	Description	Lbs	USD
681503A	3/8" nominal PEX	0.2	8.50
681524	1/2" nominal PEX	0.2	8.50
681555	5/8" nominal PEX	0.2	8.30



**682
Universal
PEX-AL-PEX fittings**

682 series fittings are compatible with any ASTM F1281 multilayer PEX-AL-PEX pipe.
Max. working pressure: 150 psi.
Working temperature for ASTM F1281 PEX-AL-PEX piping: 41 – 200°F with tubing rated 200°F.

Code	Description	Lbs	USD
682540A	1/2" PEX-AL-PEX	0.2	8.30

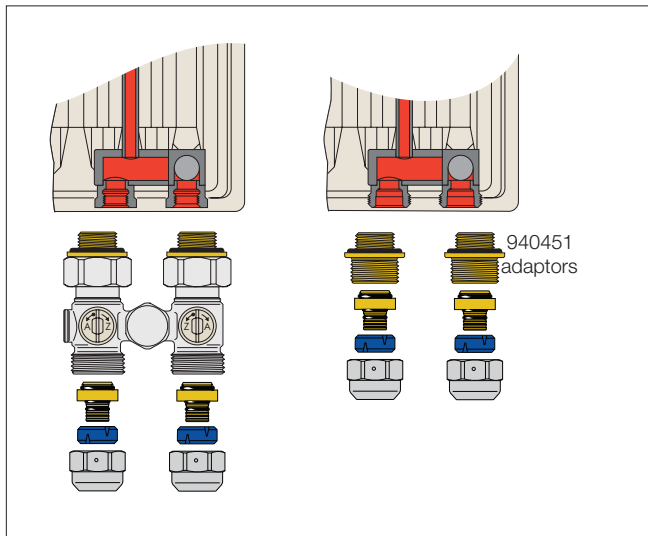

940



Radiator adapter for directly connecting a panel radiator with PEX, PEX-AL-PEX, sweat, NPT or compression fittings.
Package of 2 each, priced per package.

Code	Description	Lbs	USD
940451	1/2" M straight x 3/4" M conical (2 ea.)	0.1	15.20



Wrench for tightening PEX fitting to TRV.

Code	Description	Lbs	USD
387100	26 mm x 30 mm	1.5	38.30



437

Compression fitting, fits 1/2" hard copper.
With o-ring seal.
Max. working pressure: 150 psi.
Working temperature range: 41 – 250°F.
Chrome plated.
For connecting copper to valve 301, 338, 339, 342 and 343 series.

Code	Description	Lbs	USD
437516	1/2" compression	0.1	6.90



NA102

Sweat connection fitting fits 1/2" copper.
Max. working pressure: 150 psi.
Working temperature range: 41 – 250°F.
Chrome plated nut.
For connecting copper to valve 301, 338, 339, 342 and 343 series.

Code	Description	Lbs	USD
NA10262	1/2" sweat	0.2	9.00



NA103

NPT connection fitting.
Max. working pressure: 150 psi.
Working temperature range: 41 – 250°F.
Chrome plated nut.
For connecting copper to valve 301, 338, 339, 342 and 343 series.

Code	Description	Lbs	USD
NA10313	1/2" NPT male	0.2	9.70

ZONING DONE RIGHT INDUSTRY EXCLUSIVE 5-YEAR WARRANTY



The extremely reliable Z-one™ motorized zone valve offers quick installation and easy service in a wide variety of applications. When installed with a Z-one Relay control, featuring universal compatibility and versatility, both qualify for our industry exclusive five-year warranty. **CALEFFI GUARANTEED.**



ZONE VALVES AND ZONE CONTROLS

This diagram is for illustration purposes only

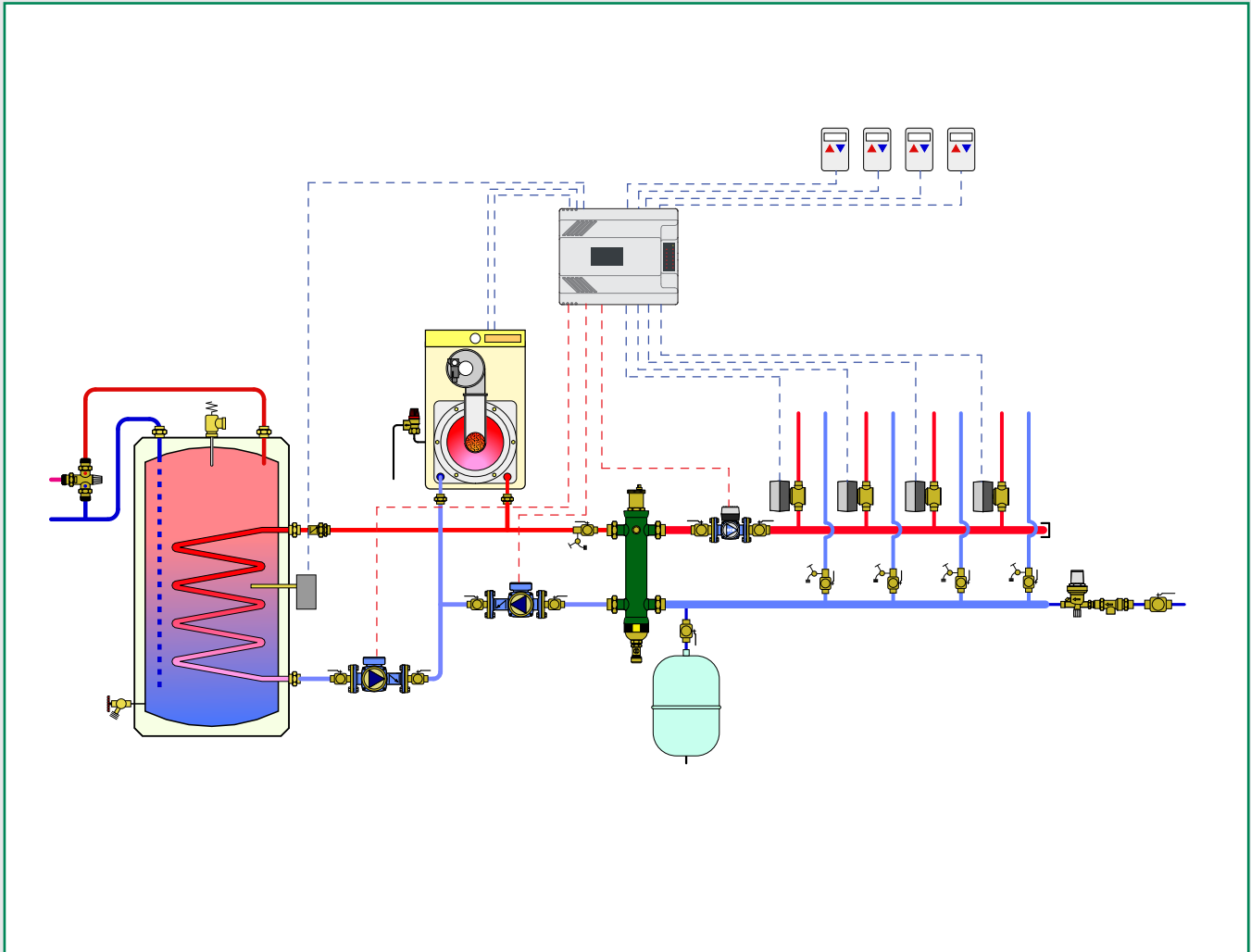

4

PRODUCTS INCLUDED IN SECTION

- Thermo-electric zone valves
- Thermo-electric actuators
- Motorized zone valves
- Pump zone controls
- Valve zone controls
- Motorized ball zone valves, high-flow, high-close off

THERMO-ELECTRIC ZONE VALVES

6767 TwisTop+™ High Performance



Complete with 656354 actuator.
 Pressure balanced body.
 40% more flow, 75% more close-off
 Spring return. Normally closed.
 Pressure balanced body.
 Brass valve body and trim.
 Max. body pressure: 150 psi.
 Max. Temperature: 200°F.
 Power supply: 24 V AC/DC.
 Initial current draw: ≤ 250 mA.
 Power consumption:
 holding: 3 W
 inrush: 6 VA
 Rating of micro-switch contacts: 5 A (24 V),
 31.5" wire lead connection.

Code	Description	Cv	ΔP	Lbs	USD
676756A	¾" press union	5.6	35 psi	2.2	184.00
676759A	¾" sweat union	5.6	35 psi	2.2	178.00
676758A	¾" PEX expansion union	5.6	35 psi	2.2	178.00
676766A	1" press union	5.6	35 psi	2.2	208.00
676769A	1" sweat union	5.6	35 psi	2.2	199.00
676768A	1" PEX expansion union	5.6	35 psi	2.2	199.00

6762 TwisTop™ Zone valve



Two-way thermo-electric zone valve.
 Complete with TwisTop™ (code 656354)
 actuator. Spring return. Normally closed.
 Brass valve body and trim.
 Max. body pressure: 150 psi.
 Max. Temperature: 200°F.
 Power supply: 24 V AC/DC.
 Initial current draw: ≤ 250 mA.
 Power consumption:
 holding: 3 W
 inrush: 6 VA
 Rating of micro-switch contacts: 5 A (24 V),
 31.5" wire lead connection.

Code	Description	Cv	ΔP	Lbs	USD
676256A	¾" press union	4	20 psi	1.4	164.00
676259A	¾" sweat union	4	20 psi	1.4	158.00
676258A	¾" PEX expansion union	4	20 psi	1.4	158.00
676266A	1" press union	4	20 psi	1.4	188.00
676269A	1" sweat union	4	20 psi	1.4	181.00
676268A	1" PEX expansion union	4	20 psi	1.4	181.00

6564



Thermo-electric actuator fits on 676 two-way
 zone valve bodies.
 Low current draw.
 Protection class (installed in all positions):
 NEMA 3 (IP54)
 Power supply: 24 V AC/DC.
 Initial current draw: ≤ 250 mA.
 Power consumption:
 holding: 3 W
 inrush: 6 VA
 Rating of micro-switch contacts: 5 A (24 V),
 31.5" wire lead connection.

Code	Description	Lbs	USD
656404	24 V AC/DC	0.4	66.30
656414	24 V AC/DC with micro-switch	0.4	83.70

6563 TwisTop™



TwisTop™ thermo-electric actuator fits on
 676 two-way valve.
 Twist the top to manually open and close
 micro-switch.
 Power supply: 24 V AC/DC.
 Initial current draw: ≤ 250 mA.
 Power consumption:
 holding: 3 W
 inrush: 6 VA
 Rating of micro-switch contacts: 5 A (24 V),
 31.5" wire lead connection.
 US Patent 7,617,989 B2.

Code	Description	Lbs	USD
656344	24 V AC/DC	0.4	88.80
656354	24 V AC/DC with micro-switch	0.4	105.00

6760, 6765



Two-way zone valve body.
 For field installation of thermo-electric
 actuators 6563 series or 6564 series.
 Brass body and trim.
 Max. body pressure: 150 psi.
 Max. temperature: 200°F.
 See fitting selection table in Section 8.
 Select fittings with 1" nut.

Code	Description	Cv	Lbs	USD
676000A	body only, close-off 20 psid	4.3	0.5	22.60
676500A	body only, close-off 35 psid	5.6	1	44.80

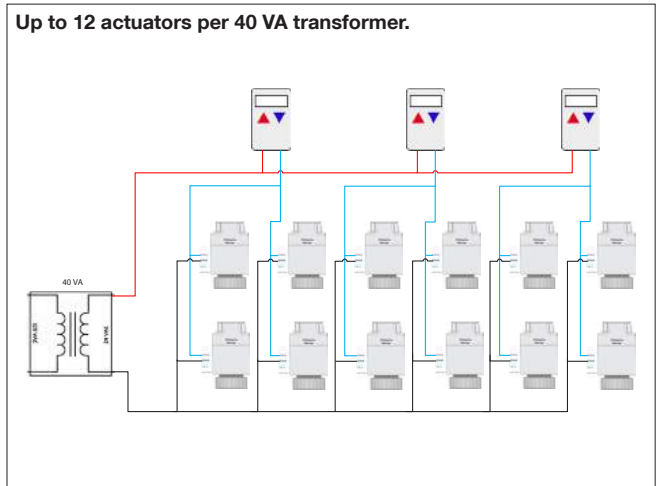

MOTORIZED ZONE VALVES



**Z4
Zone 2-way**

Two-way zone valve. Spring return.
Normally closed actuator: Z111000.
Auxiliary micro-switch.
Max. body pressure: 300 psi.
Temperature range: 32°–240°F.
Suitable fluids: water, 50% max. glycol,
15 psi max. steam.
Power supply: 24 V AC.
Power consumption: 5 W, 7 VA.
Rating of auxiliary micro-switch contacts:
0.0 A min, 0.4 A max 24 V (24 V only).
18" wire lead connection.
UL873, cULus Listed & CE.
UL 1995 sec. 18 air plenums and ducts.
US Patent 7,048,251.



**Z5
Zone 2-way**

Two-way zone valve. Spring return.
Normally closed actuator: Z151000
Auxiliary micro-switch.
Max. body pressure: 300 psi.
Temperature range: 32°–240°F.
Suitable fluids: water, 50% max. glycol,
15 psi max. steam.
Power supply: 24 V AC.
Power consumption: 5 W, 7 VA.
Rating of auxiliary micro-switch contacts:
0.0 A min, 0.4 A max 24 V (24 V only).
Screw terminal connection.
UL873, cULus Listed & CE.
UL 1995 sec. 18 air plenums and ducts.
US Patent 7,048,251.



Code	Description	Cv	Δ P	Lbs	USD
Z40	Inverted flare	3.5	30 psi	2.2	135.00
Z40F	¾" Inv flare*	3.5	30 psi	2.2	152.00
Z42	½" SAE flare	3.5	30 psi	2.2	147.00
Z44	½" sweat	2.5	50 psi	2.1	131.00
Z45	¾" sweat	7.5	20 psi	2.2	143.00
Z46	1" sweat	7.5	20 psi	2.3	178.00
Z47	1¼" sweat	7.5	20 psi	2.3	207.00

* Two ¾" sweat fittings (NA10006) included.

Code	Description	Cv	Δ P	Lbs	USD
Z50	Inverted flare	3.5	30 psi	2.2	138.00
Z50F	¾" Inv flare*	3.5	30 psi	2.2	156.00
Z54	½" sweat	2.5	50 psi	2.1	135.00
Z55	¾" sweat	7.5	20 psi	2.2	147.00
Z56	1" sweat	7.5	20 psi	2.3	181.00
Z57	1¼" sweat	7.5	20 psi	2.3	210.00

* Two ¾" sweat fittings (NA10006) included.

Zone 2-way Press



Two-way zone valve. Spring return.
Normally closed actuator: Z111000.
Auxiliary micro-switch.
Max. body pressure: 300 psi.
Overall length: 5-5/8"
Temperature range: 32–240°F.
Suitable fluids: water, 50% max. glycol,
15 psi max. steam.
Power supply: 24 V AC.
Power consumption: 5 W, 7 VA.
Rating of auxiliary micro-switch contacts:
0.0 A min, 0.4 A max 24 V (24 V only).
UL873, cULus Listed & CE.
UL 1995 sec. 18 air plenums and ducts.
US Patent 7,048,251.



Zone 2-way Sweat

Two-way zone valve. Spring return.
Normally closed actuator: Z151000
Auxiliary micro-switch.
Max. body pressure: 300 psi.
Temperature range: 32°–240°F.
Suitable fluids: water, 50% max. glycol,
15 psi max. steam.
Power supply: 24 V AC.
Power consumption: 5 W, 7 VA.
Rating of auxiliary micro-switch contacts:
0.0 A min, 0.4 A max 24 V (24 V only).
Screw terminal connection.
UL873, cULus Listed & CE.
UL 1995 sec. 18 air plenums and ducts.
US Patent 7,048,251.



Code	Description	Cv	Δ P	Lbs	USD
Z44P	½" press unions*	3.5	30 psi	2.2	181.00
Z54P	½" press unions**	3.5	30 psi	2.2	184.00
Z45P	¾" press unions*	7.5	20 psi	2.2	184.00
Z55P	¾" press unions**	7.5	20 psi	2.2	187.00
Z45PL	¾" press unions*	7.5	20 psi	2.3	202.00
Z55PL	¾" press unions**	7.5	20 psi	2.3	205.00
Z46P	1" press unions*	7.5	20 psi	2.4	208.00
Z56P	1" press unions**	7.5	20 psi	2.4	212.00

*18" wire lead connection.
**Screw terminal connection.
PL (1) extra long press fitting for retrofit
Includes press fittings.

Code	Description	Cv	Δ P	Lbs	USD
Z55S	¾" sweat unions	7.5	20 psi	2.2	178.00



Inverted flare sweat adaptors fits Z40, Z50
and inverted flare valve body.

Code	Description	Lbs	USD
NA10005	½" sweat	0.3	6.90
NA10006	¾" sweat	0.3	8.70
NA10007	1" sweat	0.4	14.40
NA61241	Retrofit extension kit	0.2	7.00

MOTORIZED ZONE VALVES



Z1

Z1 Normally closed actuators fit on Z2 and Z3 valves. Normally open actuators fit on Z2 valves only. Easy pushbutton attachment 7/8" knockout for 1/2" conduit connector. Power: 24 and 120 VAC. Power consumption: 5 W, 7 VA. Conduit connector size: 1/2". Rating of auxiliary switch contacts: 24 VAC: 0.0 A min, 0.4 A max (24 V). 120 and Z11900 VAC: 0.25 A min, 5.0 A max (230 V). UL873, cULus Listed & CE. UL 1995 sec.18 air plenums and ducts. US Patent 7,048,251.

Normally closed

Code	Description	Lbs	USD
Z111000	24 V, micro-switch, 18" wires	1.1	93.10
Z111900	24 V, high current switch, 18" wires	1.1	93.10
Z116000	120 V, micro-switch, 6" wires	1.1	93.10
Z151000	24 V, micro-switch, terminal blocks	1.1	96.50
Z161000	24 V, terminal blocks	1.1	88.60
Z121000	24 V, 18" wires	1.1	86.30
Z126000	120 V, 6" wires	1.1	86.30

Normally open

Code	Description	Lbs	USD
Z131000	24 V, micro-switch, 18" wires	1.1	102.00
Z136000	120 V, micro-switch, 6" wires	1.1	102.00
Z141000	24 V, 18" wires	1.1	94.80
Z146000	120 V, 6" wires	1.1	94.80

Function

The Z-one™ valve is a truly universal zone valve that can be used in a wide range of commercial and residential applications; from fan coils to baseboard, radiant to high rise, the Z-one™ is the professional's valve of choice. The Z-one™ can be used in both chilled or hot water and low pressure steam applications. With Delta P close off pressures of up to 75 PSI, the Z-one™ outperforms all other zone valves. The Z-one™ is available in sizes from 1/2" to 1 1/4" sweat or NPT connections on valve body, with removable actuator available in 24 to 120 voltages.

Some models of Z-one™ actuators contain an auxiliary micro-switch to operate other devices. The 24 V actuators use a sealed reed switch, which has been produced specifically for use with relays, boiler contacts (TT) and DDC systems. It requires no minimum current load. The 120 V actuators for applications requiring greater than 400 mA, use a conventional micro-switch with silver contacts. The auxiliary switch is activated when the valve is 60% open or when the actuator is manually opened.

• Manual opening (Normally closed actuator only)

The valve can be opened manually by moving the lever for opening it. When the power is restored the manual control is automatically overridden. The auxiliary switch in 24 V actuators is tripped when the unit is put into manual open position. This helps during start up to check if the wiring is correct without firing the valve electrically with the thermostat.

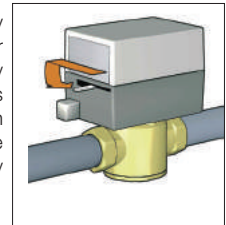

• Auxiliary micro-switch

The actuator contains an auxiliary microswitch to operate other devices. The 24 V actuators use a sealed reed switch, which has been produced specifically for use with relays, boiler contacts (TT) and DDC systems. It requires no minimum current load. The 120 V actuators use a conventional micro-switch with silver contacts. The auxiliary micro-switch is activated when the valve is 60% open or when the actuator is manually opened.

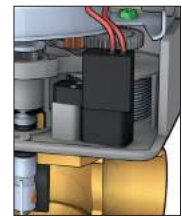

Construction details

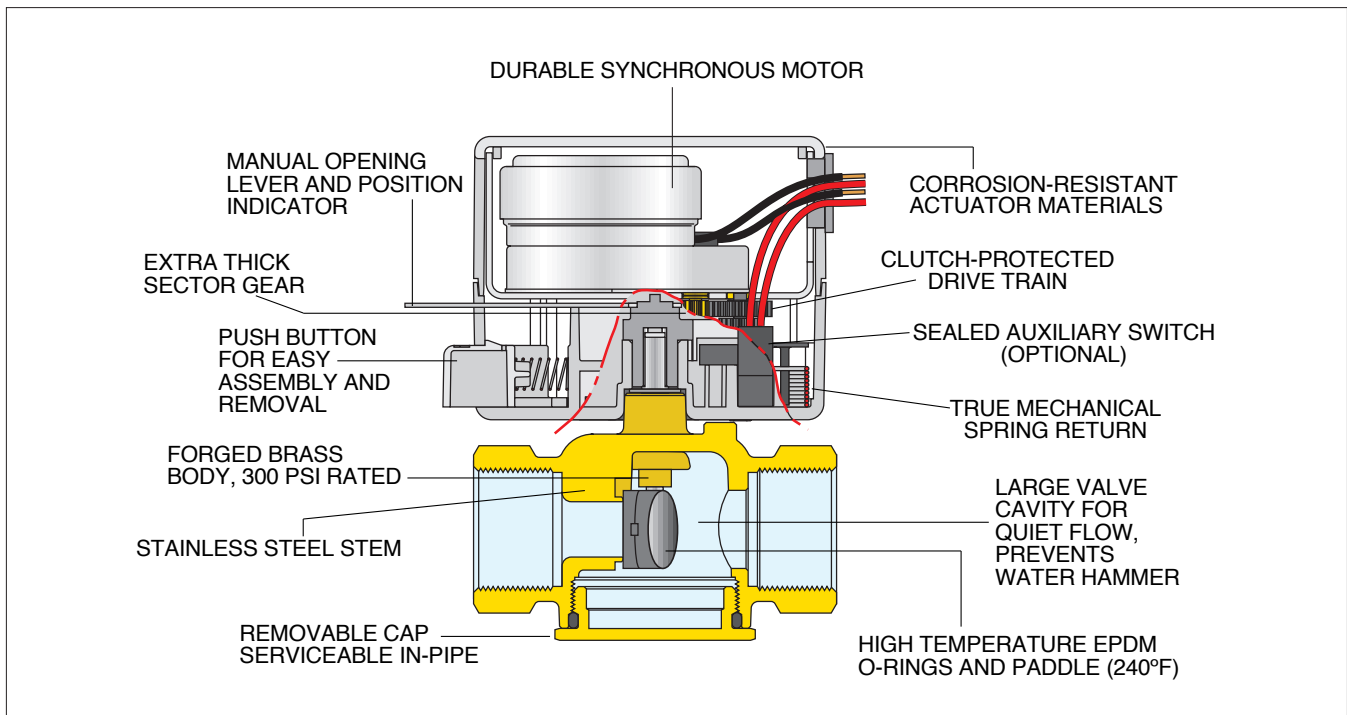

MOTORIZED ZONE VALVES



**Z2
2-way**

Two-way on/off two position valve. Straight through flow pattern. Brass body. Stainless steel stem. EPDM rubber seals and paddle. Max. working pressure: 300 psi. Max temperature: 240°F.



**Z3
3-way**

Three-way on/off two position valve. Diverting flow pattern. Brass body. Stainless steel stem. EPDM rubber seals and paddle. Max. working pressure: 300 psi. Max temperature: 240°F.

Code	Description	Cv	Δ P	Lbs	USD
Z200041	Inverted flare	1	75 psi	1.1	41.10
Z200042	Inverted flare	2.5	50 psi	1.1	41.10
Z200043	Inverted flare	3.5	30 psi	1.1	41.10
Z200053	½" SAE Flare	3.5	30 psi	1.1	52.80
Z200411	½" FNPT	1	75 psi	1.1	41.10
Z207411	½" FNPT LL	1	75 psi	1.1	56.20
Z200412	½" FNPT	2.5	50 psi	1.1	41.10
Z200413	½" FNPT	3.5	30 psi	1.1	41.10
Z200431	½" sweat	1	75 psi	1	37.60
Z200432	½" sweat	2.5	50 psi	1	37.60
Z207433	½" sweat LL	3.5	30 psi	1	52.80
Z200512	¾" FNPT	2.5	50 psi	1.2	56.20
Z200513	¾" FNPT	3.5	30 psi	1.2	56.20
Z200515	¾" FNPT	5	25 psi	1.2	56.20
Z200517	¾" FNPT	7.5	20 psi	1.2	56.20
Z200532	¾" sweat	2.5	50 psi	1.1	49.70
Z207533*	¾" sweat LL	3.5	30 psi	1.1	64.70
Z200535	¾" sweat	5	25 psi	1.1	49.70
Z200537	¾" sweat	7.5	20 psi	1.1	49.70
Z207537*	¾" sweat LL	7.5	20 psi	1.1	64.70
Z200617	1" FNPT	7.5	20 psi	1.3	88.80
Z200635	1" sweat	5	25 psi	1.2	84.40
Z200637	1" sweat	7.5	20 psi	1.2	84.40
Z200737	1¼" sweat	7.5	20 psi	1.3	112.00

LL Low-lead brass body.



Two-way and three-way zone valve body repair kit. Includes valve stem paddle with O-rings, C clip and one bottom cap O-ring.

Code	Description	Lbs	USD
F69293	Fits all ½" & ¾" sweat Z2, Z3	0.4	14.20
F69294	Fits all ¾" NPT and all 1", 1¼" Z2, Z3	0.4	14.20

Code	Description	Cv	Δ P	Lbs	USD
Z300053	½" SAE Flare	3.5	30 psi	1.1	65.80
Z300411	½" FNPT	1	75 psi	1.1	54.80
Z300412	½" FNPT	2.5	50 psi	1.1	54.80
Z300413	½" FNPT	3.5	30 psi	1.1	54.80
Z300431	½" sweat	1	75 psi	1	51.40
Z300432	½" sweat	2.5	50 psi	1	51.40
Z307433*	½" sweat LL	3.5	30 psi	1	66.30
Z300512	¾" FNPT	2.5	50 psi	1.2	68.50
Z300513	¾" FNPT	3.5	30 psi	1.2	68.50
Z300515	¾" FNPT	5	25 psi	1.2	68.50
Z300517	¾" FNPT	7.5	20 psi	1.2	68.50
Z300532	¾" sweat	2.5	50 psi	1.1	63.50
Z300533	¾" sweat	3.5	30 psi	1.1	63.50
Z300535	¾" sweat	5	25 psi	1.1	63.50
Z307537*	¾" sweat LL	7.5	20 psi	1.1	78.60
Z300617	1" FNPT	7.5	20 psi	1.3	103.00
Z300635	1" sweat	5	25 psi	1.2	95.60
Z300637	1" sweat	7.5	20 psi	1.2	95.60
Z300737	1¼" sweat	7.5	20 psi	1.3	116.00

***LL** Low-lead brass body.



2-way male union valve body. Select fittings in Section 8 Table.

Code	Description	Cv	Δ P	Lbs	USD
Z200683	1" male union body	3.5	30 psi	1.1	56.20
Z200687	1" male union body	7.5	20 psi	1.1	56.20



3-way male union valve body. Select fittings in Section 8 Table.

Code	Description	Cv	Δ P	Lbs	USD
Z300687	1" male union body	7.5	20 psi	1.2	71.40

PUMP ZONE CONTROLS



Certified to CSA C22-2 No.24
Conforms to UL Standard 873

ZSR
Z-one Relay

The ZSR series is multi-zone pump and boiler operating control for multiple zone hydronic heating systems. The ZSR series interfaces with low voltage thermostats, or any other low voltage controllers having a switching action. The ZSR series controls up to 3, 4, 5 or 6 heating circulator pumps, depending on model selected, a primary pump and has LED indicators to provide functional status and easy system troubleshooting. In addition, a primary pump system circulator is switched on whenever any zone calls for heat.

- Power supply: 120 VAC, 50/60 Hz
- Transformer voltage: 24 VAC
- Maximum transformer load: 12 VA (ZSR101/103/104), 20 VA (ZSR106)
- Electrical switch rating: 10A (ZSR101), 20A (ZSR103/4/6) max combined
- Electrical switch rating pump output: 120 VAC, 5A each
- Dry contact rating: AUX, XX, ZONE1 E/S: 120 VAC max, 2A each
- Replaceable fuses: Type 2AG, 5A slow blow

Code	Description	Lbs	USD
ZSR101	Single zone relay	1.0	104.00
ZSR103	3 zone pump control	2.0	245.00
ZSR104	4 zone pump control	2.0	287.00
ZSR106	6 zone pump control	2.0	351.00

VALVE ZONE CONTROLS



Certified to CSA C22-2 No.24
Conforms to UL Standard 873

ZVR
Z-one Relay

The ZVR series is a multi-zone valve relay and boiler operating control for multiple zone hydronic heating systems. The ZVR series interfaces with low voltage thermostats, or any other low voltage controllers having a switching action. The ZVR series controls up to 3, 4, 5 or 6 zones, depending on model selected. In addition, a system circulator pump and secondary pump is turned on whenever any zone calls for heat. LED indicators provide functional status and easy system troubleshooting. The ZVR series is a perfect match with Caleffi's Z-one™ motorized zone valves.

- Power supply: 120 VAC, 50/60 Hz
- Transformer voltage: 24 VAC
- Maximum transformer load: 40 VA (ZVR103/4), 80 VA (ZVR106)
- Electrical switch rating: 20A Max Combined
- Electrical switch rating pumps: 120 VAC, 5A each
- Dry contact rating: AUX, XX, ZONE1 E/S:120 VAC, 2A each
- Resettable Fuse: automatic

High Capacity 40 VA Transformer standard for 3 and 4 zone models- expandable to 80 VA, and 80 VA for the 6 zone model

Code	Description	Lbs	USD
ZVR103	3 zone valve control	2.0	186.00
ZVR104	4 zone valve control	2.0	221.00
ZVR106	6 zone valve control	2.0	287.00
NA10343	Expansion transformer	0.1	60.20

Z-ONE RELAY FUSES

Code	Description	Lbs	USD
NA10342	Spare fuse (package of 5)	0.1	10.00

MOTORIZED BALL ZONE VALVES HIGH-FLOW, HIGH CLOSE-OFF



**6442
2-way Straight**

Two-way motorized ball zone valve. Straight.
Max. ΔP close-off pressure: 150 psi.
Temperature range: 20°–230°F.
Power supply: 24 VAC.
Power consumption: 4 VA.
Rating of micro-switch contacts: 5 A (24 V).
3-wire control.
36" wire lead connection.

Code	Description	Cv	Lbs	USD
644250A	¾" NPT male union	13	2.3	262.00
644256A	¾" press union	13	2.4	262.00
644259A	¾" sweat union	13	2.3	257.00
644260A	1" NPT male union	13	2.3	284.00
644266A	1" press union	13	2.4	286.00
644269A	1" sweat union	13	2.3	278.00
NA644200*	body, with no fittings	13	1.0	228.00

*See fitting selection table in Section 8.

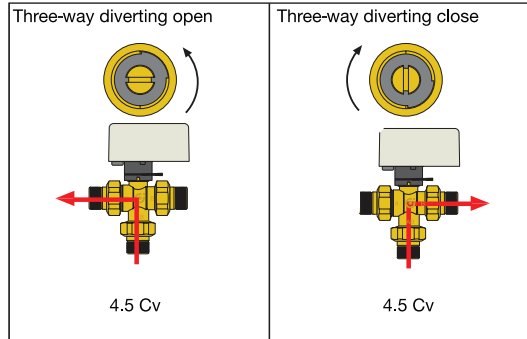
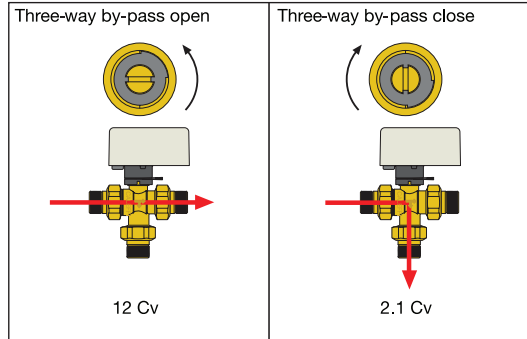
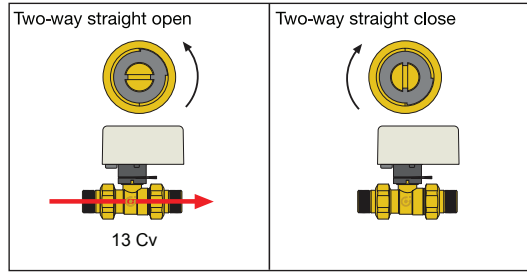

**6443..3BY
3-way By-pass**

Three-way motorized ball zone valve. By-pass.
Max. ΔP close-off pressure: 150 psi.
Temperature range: 20°–230°F.
Power supply: 24 VAC.
Power consumption: 4 VA.
Rating of micro-switch contacts: 5 A (24 V).
3-wire control.
2.1 Cv in by-pass mode.
36" wire lead connection.

Code	Description	Cv	Lbs	USD
644350A 3BY	¾" NPT male union	12	2.5	283.00
644356A 3BY	¾" press union	12	2.6	298.00
644359A 3BY	¾" sweat union	12	2.5	290.00
644360A 3BY	1" NPT male union	12	2.5	329.00
644366A 3BY	1" press union	12	2.6	334.00
644369A 3BY	1" sweat union	12	2.5	321.00
NA644300 3BY*	body, no fittings	12	1.2	247.00

*See fitting selection table in Section 8.



**6443
3-way Diverting**

Three-way motorized ball zone valve. Diverting.
Max. ΔP close-off pressure: 150 psi.
Temperature range: 20°–230°F.
Power supply: 24 VAC.
Power consumption: 4 VA.
Rating of micro-switch contacts: 5 A (24 V).
3-wire control.
36" wire lead connection.



**6440
24 V 3-wire control**

Actuator fits 6442 and 6443 series.
Power supply: 24 VAC.
Power consumption: 4 VA.
Rating of micro-switch contacts: 5 A (24 V).
Operating time: 40 s (90° rotation).
Length of supply cable: 36".

Code	Description	Lbs	USD
644004	24 VAC	1.0	154.00

Code	Description	Cv	Lbs	USD
644350A	¾" NPT male union	4.5	2.5	283.00
644356A	¾" press union	4.5	2.6	298.00
644359A	¾" sweat union	4.5	2.5	290.00
644360A	1" NPT male union	4.5	2.5	329.00
644366A	1" press union	4.5	2.6	334.00
644369A	1" sweat union	4.5	2.5	321.00
NA644300*	body, no fittings	4.5	1.2	247.00

*See fitting selection table in Section 8.

EASY-ACCESS INSTALLATION TIP VIDEOS



Whether you're a contractor in the mechanical room looking for installation pointers or a wholesaler explaining a component at the counter, Caleffi's Installation Tip videos just made your job easier! Simply scan the QR code, easily identified with a bright-yellow label placed on our product boxes, to access the brief YouTube videos. **CALEFFI GUARANTEED.**

DISTRIBUTION MANIFOLDS AND TEMPERATURE MIXING STATIONS

This diagram is for illustration purposes only

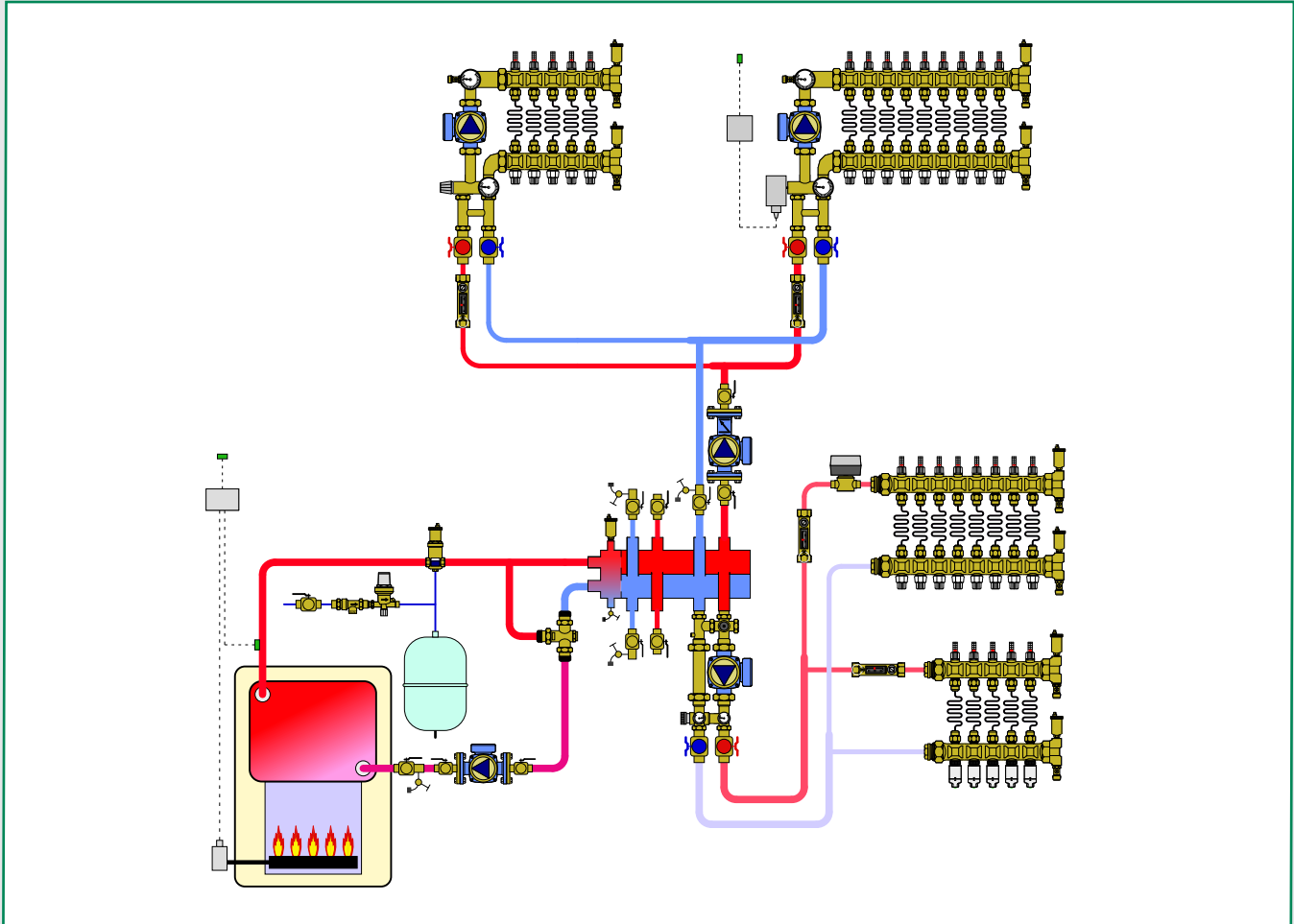

5

PRODUCTS INCLUDED IN SECTION

- Thermostatic manifold mixing stations
- Manifold mixing stations
- Brass distribution manifolds
- Distribution manifolds
- Pump and valve temperature mixing units
- Fittings for distribution manifolds and mixing stations
- Boxes for distribution manifolds
- Thermo electric actuators for manifolds and valves
- Accessories

THERMOSTATIC MANIFOLD MIXING STATIONS

**172
Manifold mixing station
three speed pump**

Pre-assembled thermostatic manifold mixing station consisting of a supply distribution manifold complete with built-in sight flow gauges and adjustable balancing valves. Return manifold with built-in shutoff valves is suitable for thermo-electric actuators. Complete with built-in sensor to keep flow temperature at constant set value.

Includes Grundfos UPS 15–58 three-speed pump.

¾" F NPT supply/return ball valves.

Max. working pressure: 150 psi.

Control temperature range: 80°–130°F.

Primary inlet max. temperature: 195°F.

Outlet center distance: 2 in.

Models with "...IN" suffix are built inverted (tubing connections going upward).



Code	Description	UPS Pump	No.	Outlets	Lbs	USD
1725C1A	¾"	15-58	3	¾" M	20	1,067.00
1725C1A IN	¾"	15-58	3	¾" M	20	1,067.00
1725D1A	¾"	15-58	4	¾" M	21	1,136.00
1725D1A IN	¾"	15-58	4	¾" M	21	1,136.00
1725E1A	¾"	15-58	5	¾" M	23	1,205.00
1725E1A IN	¾"	15-58	5	¾" M	23	1,205.00
1725F1A	¾"	15-58	6	¾" M	25	1,274.00
1725F1A IN	¾"	15-58	6	¾" M	25	1,274.00
1725G1A	¾"	15-58	7	¾" M	27	1,343.00
1725G1A IN	¾"	15-58	7	¾" M	27	1,343.00
1725H1A	¾"	15-58	8	¾" M	28	1,412.00
1725H1A IN	¾"	15-58	8	¾" M	28	1,412.00
1725I1A	¾"	15-58	9	¾" M	29	1,480.00
1725I1A IN	¾"	15-58	9	¾" M	29	1,480.00
1725L1A	¾"	15-58	10	¾" M	31	1,549.00
1725L1A IN	¾"	15-58	10	¾" M	31	1,549.00
1725M1A	¾"	15-58	11	¾" M	33	1,617.00
1725M1A IN	¾"	15-58	11	¾" M	33	1,617.00
1725N1A	¾"	15-58	12	¾" M	34	1,687.00
1725N1A IN	¾"	15-58	12	¾" M	34	1,687.00
1725O1A	¾"	15-58	13	¾" M	36	1,755.00
1725O1A IN	¾"	15-58	13	¾" M	36	1,755.00

**172
Manifold mixing station
high efficiency pump**

Pre-assembled thermostatic manifold mixing station consisting of a supply distribution manifold complete with built-in sight flow gauges and adjustable balancing valves. Return manifold with built-in shutoff valves is suitable for thermo-electric actuators. Complete with built-in sensor to keep flow temperature at constant set value.

Includes Grundfos Alpha 25-55U pump.

¾" F NPT supply/return ball valves.

Max. working pressure: 150 psi.

Control temperature range: 80°–130°F.

Primary inlet max. temperature: 195°F.

Outlet center distance: 2 in.

Models with "...IN" suffix are built inverted (tubing connections going upward).



Code	Description	Alpha Pump	No.	Outlets	Lbs	USD
1725C1AHE	¾"	25-55U	3	¾" M	20	1,281.00
1725C1AHE IN	¾"	25-55U	3	¾" M	20	1,281.00
1725D1AHE	¾"	25-55U	4	¾" M	21	1,349.00
1725D1AHE IN	¾"	25-55U	4	¾" M	21	1,349.00
1725E1AHE	¾"	25-55U	5	¾" M	23	1,418.00
1725E1AHE IN	¾"	25-55U	5	¾" M	23	1,418.00
1725F1AHE	¾"	25-55U	6	¾" M	25	1,486.00
1725F1AHE IN	¾"	25-55U	6	¾" M	25	1,486.00
1725G1AHE	¾"	25-55U	7	¾" M	27	1,556.00
1725G1AHE IN	¾"	25-55U	7	¾" M	27	1,556.00
1725H1AHE	¾"	25-55U	8	¾" M	28	1,624.00
1725H1AHE IN	¾"	25-55U	8	¾" M	28	1,624.00
1725I1AHE	¾"	25-55U	9	¾" M	29	1,693.00
1725I1AHE IN	¾"	25-55U	9	¾" M	29	1,693.00
1725L1AHE	¾"	25-55U	10	¾" M	31	1,763.00
1725L1AHE IN	¾"	25-55U	10	¾" M	31	1,763.00
1725M1AHE	¾"	25-55U	11	¾" M	33	1,831.00
1725M1AHE IN	¾"	25-55U	11	¾" M	33	1,831.00
1725N1AHE	¾"	25-55U	12	¾" M	34	1,900.00
1725N1AHE IN	¾"	25-55U	12	¾" M	34	1,900.00
1725O1AHE	¾"	25-55U	13	¾" M	36	1,969.00
1725O1AHE IN	¾"	25-55U	13	¾" M	36	1,969.00

THERMOSTATIC MANIFOLD MIXING STATIONS

Characteristic components / hydraulic diagram

Item	Description	Symbol
1	Circulation pump UPS 15-58 pictured	
2	Top elbow with supply temperature and pressure gauge	
3	Purge valve	
4	Supply temperature and pressure gauge	
5	Return temperature gauge	
6	Primary circuit shut-off valves	
7	Primary circuit hydraulic separator with check valve	
8	Thermostatic three-way mixing valve with built-in sensor	

Supply manifold equipped with flow meters and balancing valves.

Return manifold equipped with shut-off valves.

End fittings with automatic air vent with hygroscopic cap and drain cock.

Function

The 172 series manifold mixing station is designed for use in manifold-based hydronic distribution systems. The manifold mixing station incorporates a thermostatic actuator with built-in sensor which keeps the flow temperature at a constant set value for use in low temperature systems such as floor radiant panels. A removable primary circuit hydraulic separator with check valve is also supplied. The hydraulic separator is essential when there is a primary circuit circulation pump and when radiator circuits or fan coils are controlled by

thermostatic or thermo-electric valves. When connecting to a Caleffi HYDROLINK™ or hydraulic separator without a primary pump, the hydraulic separator can be removed and the manifold mixing station can be connected directly. The 172 station, like the TWISTFLOW™ Series 668S1 distribution manifolds, can be configured with 3 to 13 circuit outlets offering similar benefits with built-in sight flow meters/adjustable balancing valves and optional TWISTOP™ thermo-electric zone actuators.

MANIFOLD MIXING STATIONS



Thermostatic mixing station kit

For field assembly to a Caleffi radiant manifold assembly.
Grundfos UPS 15—58 three-speed pump or Alpha 25-55U.
1" NPT male adapters included to connect to manifold.
¾" NPT female riser connections.
Includes built-in hydraulic separator.

Code	Description	Lbs	USD
NA17256HE	Thermostatic mixing, Alpha 25-55U	4.1	988.00
NA17256	Thermostatic mixing, UPS 15-58U	4.1	775.00
NA16002	Alpha 25-55U replacement pump	2.3	424.00
NA10038	UPS 15-58U replacement pump	2.3	209.00
F19153	Replacement mixing valve	1.6	235.00

BRASS DISTRIBUTION MANIFOLDS

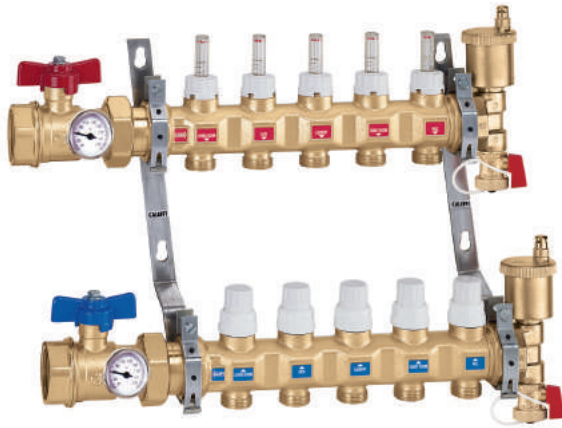

**668S1
TwistFlow™ assembly**

Pre-assembled radiant manifold consisting of return distribution manifold complete with built-in shut-off valves suitable for thermo-electric actuator and supply distribution manifold complete with built-in sight flow meters and balancing valves with 2" gauges 30—210°F scale. 1" or 1¼" NPT inlet ball valves.

Temperature gauges.

Max. working pressure: 150 psi.

Max. working temperature: 180°F.

Max. peak temperature: 200°F.

Loop Cv: 1.23 (combined supply & return ports).

Flow meter scale: ¼ — 2 gpm.

Outlet center distance: 2 in.

Models with "...IN" suffix are built inverted (tubing connections going upward).

Code	Description	No.	Outlets	Lbs	USD
6686C5S1A	1"	3	¾" M	17	493.00
6686C5S1A IN	1"	3	¾" M	17	493.00
6686D5S1A	1"	4	¾" M	18	564.00
6686D5S1A IN	1"	4	¾" M	18	564.00
6686E5S1A	1"	5	¾" M	19	635.00
6686E5S1A IN	1"	5	¾" M	19	635.00
6686F5S1A	1"	6	¾" M	21	708.00
6686F5S1A IN	1"	6	¾" M	21	708.00
6686G5S1A	1"	7	¾" M	23	778.00
6686G5S1A IN	1"	7	¾" M	23	778.00
6686H5S1A	1"	8	¾" M	24	851.00
6686H5S1A IN	1"	8	¾" M	24	851.00
6686I5S1A	1"	9	¾" M	26	922.00
6686I5S1A IN	1"	9	¾" M	26	922.00
6686L5S1A	1"	10	¾" M	28	993.00
6686L5S1A IN	1"	10	¾" M	28	993.00
6686M5S1A	1"	11	¾" M	29	1,065.00
6686M5S1A IN	1"	11	¾" M	29	1,065.00
6686N5S1A	1"	12	¾" M	31	1,136.00
6686N5S1A IN	1"	12	¾" M	31	1,136.00
6686O5S1A	1"	13	¾" M	33	1,209.00
6686O5S1A IN	1"	13	¾" M	33	1,209.00

Code	Description	No.	Outlets	Lbs	USD
6687C5S1A	1¼"	3	¾" M	17	522.00
6687C5S1A IN	1¼"	3	¾" M	17	522.00
6687D5S1A	1¼"	4	¾" M	18	594.00
6687D5S1A IN	1¼"	4	¾" M	18	594.00
6687E5S1A	1¼"	5	¾" M	19	666.00
6687E5S1A IN	1¼"	5	¾" M	19	666.00
6687F5S1A	1¼"	6	¾" M	21	736.00
6687F5S1A IN	1¼"	6	¾" M	21	736.00
6687G5S1A	1¼"	7	¾" M	23	808.00
6687G5S1A IN	1¼"	7	¾" M	23	808.00
6687H5S1A	1¼"	8	¾" M	24	880.00
6687H5S1A IN	1¼"	8	¾" M	24	880.00
6687I5S1A	1¼"	9	¾" M	26	952.00
6687I5S1A IN	1¼"	9	¾" M	26	952.00
6687L5S1A	1¼"	10	¾" M	28	1,023.00
6687L5S1A IN	1¼"	10	¾" M	28	1,023.00
6687M5S1A	1¼"	11	¾" M	29	1,094.00
6687M5S1A IN	1¼"	11	¾" M	29	1,094.00
6687N5S1A	1¼"	12	¾" M	31	1,166.00
6687N5S1A IN	1¼"	12	¾" M	31	1,166.00
6687O5S1A	1¼"	13	¾" M	33	1,237.00
6687O5S1A IN	1¼"	13	¾" M	33	1,237.00

Manifolds and accessories

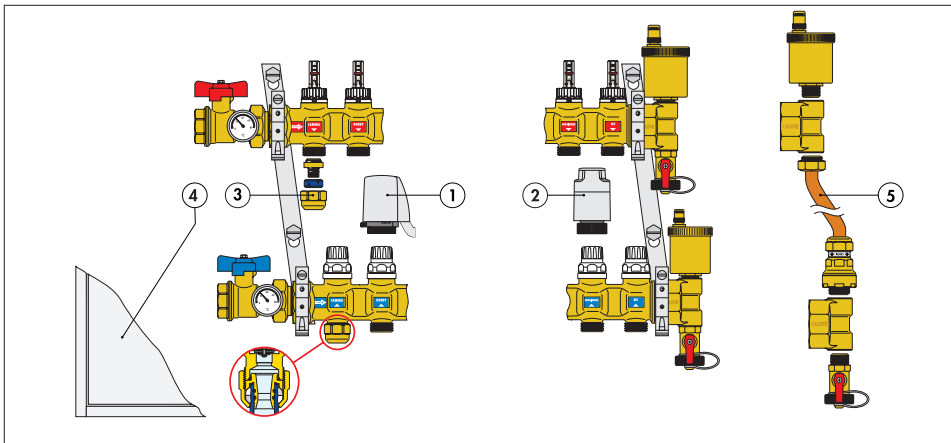

1. Thermo-electric actuator 6564 series.
2. Thermo-electric actuator with manual open handle, 6563 series.
3. Self-adjusting Universal PEX fitting, 680, 682 series.
4. Inspection wall box, 659 series.
5. Differential by-pass kit, code 668000.

DISTRIBUTION MANIFOLDS

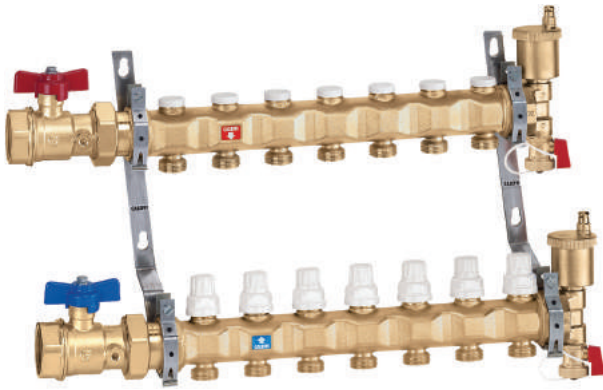

**663
Pre-assembled distribution
assembly**

Pre-assembled distribution assembly consisting of return distribution manifold complete with built-in shut-off valves suitable for thermo-electric actuator and supply distribution manifold complete with manually-adjustable balancing valves.

1" or 1¼" NPT inlet ball valves.

Loop Cv: 2.3 (combined supply & return ports).

Max. working pressure: 150 psi.

Max. temperature: 210°F.

Outlet center distance: 2 in.

Models with "...IN" suffix are built inverted (tubing connections going upward).

Code	Description	No.	Outlets	Lbs	USD
6636C5A	1"	3	¾" M	17	403.00
6636C5A IN	1"	3	¾" M	17	403.00
6636D5A	1"	4	¾" M	18	466.00
6636D5A IN	1"	4	¾" M	18	466.00
6636E5A	1"	5	¾" M	19	528.00
6636E5A IN	1"	5	¾" M	19	528.00
6636F5A	1"	6	¾" M	21	591.00
6636F5A IN	1"	6	¾" M	21	591.00
6636G5A	1"	7	¾" M	23	653.00
6636G5A IN	1"	7	¾" M	23	653.00
6636H5A	1"	8	¾" M	24	716.00
6636H5A IN	1"	8	¾" M	24	716.00
6636I5A	1"	9	¾" M	26	778.00
6636I5A IN	1"	9	¾" M	26	778.00
6636L5A	1"	10	¾" M	28	842.00
6636L5A IN	1"	10	¾" M	28	842.00
6636M5A	1"	11	¾" M	29	904.00
6636M5A IN	1"	11	¾" M	29	904.00
6636N5A	1"	12	¾" M	31	966.00
6636N5A IN	1"	12	¾" M	31	966.00
6636O5A	1"	13	¾" M	33	1,029.00
6636O5A IN	1"	13	¾" M	33	1,029.00
6636P5A	1"	14	¾" M	35	1,240.00
6636P5A IN	1"	14	¾" M	35	1,240.00

Code	Description	No.	Outlets	Lbs	USD
6637C5A	1¼"	3	¾" M	17	429.00
6637C5A IN	1¼"	3	¾" M	17	429.00
6637D5A	1¼"	4	¾" M	18	492.00
6637D5A IN	1¼"	4	¾" M	18	492.00
6637E5A	1¼"	5	¾" M	19	554.00
6637E5A IN	1¼"	5	¾" M	19	554.00
6637F5A	1¼"	6	¾" M	21	617.00
6637F5A IN	1¼"	6	¾" M	21	617.00
6637G5A	1¼"	7	¾" M	23	679.00
6637G5A IN	1¼"	7	¾" M	23	679.00
6637H5A	1¼"	8	¾" M	24	743.00
6637H5A IN	1¼"	8	¾" M	24	743.00
6637I5A	1¼"	9	¾" M	26	804.00
6637I5A IN	1¼"	9	¾" M	26	804.00
6637L5A	1¼"	10	¾" M	28	867.00
6637L5A IN	1¼"	10	¾" M	28	867.00
6637M5A	1¼"	11	¾" M	29	929.00
6637M5A IN	1¼"	11	¾" M	29	929.00
6637N5A	1¼"	12	¾" M	31	993.00
6637N5A IN	1¼"	12	¾" M	31	993.00
6637O5A	1¼"	13	¾" M	33	1,056.00
6637O5A IN	1¼"	13	¾" M	33	1,056.00
6637P5A	1¼"	14	¾" M	35	1,209.00
6637P5A IN	1¼"	14	¾" M	35	1,209.00

Construction

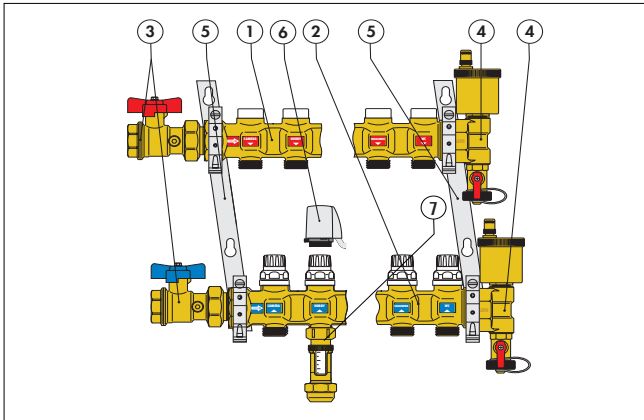

1. Supply manifold.
2. Return manifold complete with shut-off valves that can be used with thermo-electric actuators.
3. Pair of shut-off ball valves (complete with port for optional temperature gauge only for 1 1/4" version).
4. End fittings consisting of a 3-way end fitting, automatic air vent valve and drain cock.
5. Pair of mounting brackets for use with series 659 boxes or direct wall installation.
6. Thermo-electric actuator, series 6564 or 6563.
7. Flow meter, code NA669.

PUMP & VALVE TEMPERATURE MIXING UNITS



165 HydroMixer™

Injection pump mixing unit with insulation. Grundfos UPS 15-58 three speed pump. Grundfos Alpha 25-55U pump. Temperature gauges. Shut-off ball valves. Compatible with 5599 Hydrolink™ series Male union connections (select top and bottom fitting sets on page 35). Max working pressure: 145 psi. Max. working temperature: 212°F. Power supply: 115 V 50/60 Hz.

Code	Description	Lbs	USD
165600A	Dual line with 15-58 pump on right	21	916.00
165610A	Dual line with 15-58 pump on left	21	916.00
165602A	Dual line with Alpha pump on right	21	1,118.00
165612A	Dual line with Alpha pump on left	21	1,118.00



167 HydroMixer™

Motorized temperature mixing unit with insulation. Three-point floating 24 VAC actuator for use with separately-sourced outdoor reset controller. Grundfos UPS 15-58 three speed pump. Grundfos Alpha 25-55U pump. Temperature gauges. Shut-off ball valves. Compatible with 5599 Hydrolink™ series Male union connections (select top and bottom fitting sets below). Max working pressure: 145 psi. Primary inlet temperature range: 40-212°F. Power supply: 115 V 50/60 Hz. Valve actuator: 24 V AC

Code	Description	Lbs	USD
167600A	Dual line with 15-58 pump on right	23	1,322.00
167610A	Dual line with 15-58 pump on left	23	1,322.00
167602A	Dual line with Alpha pump on right	23	1,525.00
167612A	Dual line with Alpha pump on left	23	1,525.00



166 HydroMixer™

Thermostatic adjustable temperature mixing unit with insulation. Grundfos UPS 15-58 three speed pump. Grundfos Alpha 25-55U pump. Temperature gauges. Shut-off ball valves. Compatible with 5599 Hydrolink™ series Male union connections (select top and bottom fitting sets below). Max working pressure: 145 psi. Adjustable range: 80–125°F. Power supply: 115 V 50/60 Hz.

Code	Description	Lbs	USD
166600A	Dual line with 15-58 pump on right	22	1,118.00
166610A	Dual line with 15-58 pump on left	22	1,118.00
166602A	Dual line with Alpha pump on right	22	1,322.00
166612A	Dual line with Alpha pump on left	22	1,322.00



Top outlet fitting set fits 165, 166, 167 series. Includes (2) 1 1/4" union nuts, (2) tail pieces and (2) washers. Will not fit bottom inlet thread.

Code	Description	Lbs	USD
NA16069	1" sweat union outlet fittings	1.0	52.60



Bottom Inlet fitting set fit 165, 166, 167 series. Includes (2) 1 1/2" union nuts, (2) tail pieces and (2) washers. Will not fit top outlet thread.

Code	Description	Lbs	USD
NA16169	1" sweat union inlet fittings	1.0	53.10



Wall bracket fits 165, 166 and 167 series.

Code	Description	Lbs	USD
165001	Wall bracket	0.1	51.10



Top outlet fitting set fits 165, 166, 167 series. Includes (2) 1 1/4" union nuts, (2) tail pieces and (2) washers. Will not fit bottom inlet thread.

Code	Description	Lbs	USD
NA16060	1" NPT female union outlet fittings	1.0	59.60



Optional differential pressure by-pass valve fits 165, 166 and 167 series.

Code	Description	Lbs	USD
519006	Differential pressure by-pass valve	1.0	57.30



Bottom Inlet fitting set fit 165, 166, 167 series. Includes (2) 1 1/2" union nuts, (2) tail pieces and (2) washers. Will not fit top outlet thread.

Code	Description	Lbs	USD
NA16160	1" NPT female union inlet fittings	1.0	60.20

FITTINGS FOR DISTRIBUTION MANIFOLDS AND MIXING STATIONS



(680504A shown)

**680
Universal
PEX fittings**

680 series fittings are compatible with any ASTM F876 single layer PEX.
Max. working pressure: 150 psi.
Working temperature range for ASTM F876 PEX piping: 40–180°F.

Code	Description	Compression ring	Lbs	USD
680507	5/16" nominal PEX	Blue	0.2	8.10
680503A	3/8" nominal PEX	Black	0.2	8.10
680504A	1/2" nominal PEX	Blue	0.2	8.10
680555A	5/8" nominal PEX	Black	0.2	8.10
680505A	3/4" nominal PEX	Brass	0.2	8.10



(682530A shown)

**682
Universal
PEX-AL-PEX fittings**

682 series fittings are compatible with any ASTM F1281 multilayer PEX-AL-PEX pipe.
Max. working pressure: 150 psi.
Working temperature range for ASTM F1281 PEX-AL-PEX piping: 40–200°F with tubing rated 200°F.

Code	Description	Lbs	USD
682530A	3/8" nominal PEX-AL-PEX	0.2	8.30
682540A	1/2" nominal PEX-AL-PEX	0.2	8.30
682545A	5/8" nominal PEX-AL-PEX	0.2	8.90
682550A	3/4" nominal PEX-AL-PEX	0.2	15.70



Double nipple for coupling PEX fittings.

Code	Description	Lbs	USD
942550	3/4" x 3/4" thread	0.1	10.00



Wrench for tightening PEX fitting to manifolds.

Code	Description	Lbs	USD
387100	26 mm x 30 mm	1.5	38.30



NA102

Sweat connection fitting fits 1/2" copper.
Max. working pressure: 150 psi.
Working temperature range: 41–250°F.
Chrome plated nut.
Does not work with 668S1 and 172 series.

Code	Description	Lbs	USD
NA10262	1/2" sweat	0.2	9.00



NA103

NPT connection fitting.
Max. working pressure: 150 psi.
Working temperature range: 41–250°F.
Chrome plated nut.
Does not work with 668S1 and 172 series.

Code	Description	Lbs	USD
NA10313	1/2" NPT male	0.2	9.70



386

Cap to plug unused manifold outlets on 592, 663 and 668S1 series.

Code	Description	Lbs	USD
386500	3/4" straight thread	0.2	8.10

BOXES FOR DISTRIBUTION MANIFOLDS



**659
Manifold cabinet**

Housing wall box fits 663 and 668S1 series manifolds.
Adjustable depth: 4 3/8" – 5 1/2".
Powder coated painted 18 gauge sheet metal.
With push-fit clamp.

Code	Description	H	Max Outlets	Lbs	USD
659044	16" width	20"	3	17	260.00
659064	24" width	20"	6	23	284.00
659084	32" width	20"	10	30	334.00
659104	40" width	20"	13	37	384.00
659124	48" width"	20"	17	44	434.00

Rough opening dimensions

THERMO ELECTRIC ACTUATORS FOR MANIFOLDS AND VALVES



**6563
TwisTop™**

TwisTop™ thermo-electric actuator. Twist the top to manually open. Power supply: 24 V AC/DC. Initial current draw: ≤ 250 mA. Power consumption: 3 W. Rating of micro-switch contacts: 5 A (24 V). 31.5" wire lead connection. US Patent 7,617,989 B2.



6564

Low current draw thermo-electric actuator. Hermetically sealed for upside down installation. Pop-up feature. Power supply: 24 V AC/DC. Initial current draw: ≤ 250 mA. Power consumption: 3 W. Rating of micro-switch contacts: 5 A (24 V). 31.5" wire lead connection.

Code	Description	Lbs	USD
656344	24 V AC/DC	0.4	88.80
656354	24 V AC/DC with micro-switch	0.4	105.00
656354R	24 V AC/DC with micro-switch Rehau	0.4	115.00

Code	Description	Lbs	USD
656404	24 V AC/DC	0.4	66.30
656414	24 V AC/DC with micro-switch	0.4	83.70

Simply twist to manually open actuator (and activate micro switch on 656354). When power is applied, it returns to Auto position.

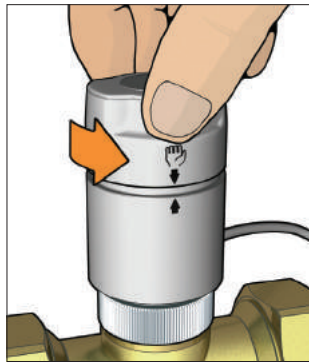

Green ring indicates valve is open.

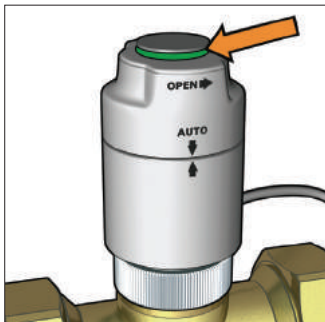

Construction details

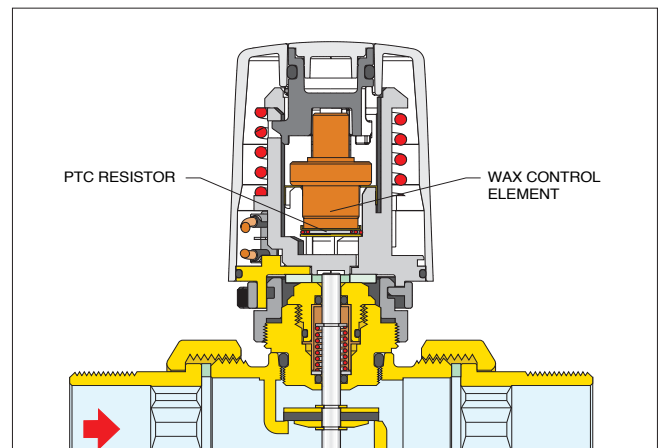

Up to 12 actuators per 40 VA transformer.

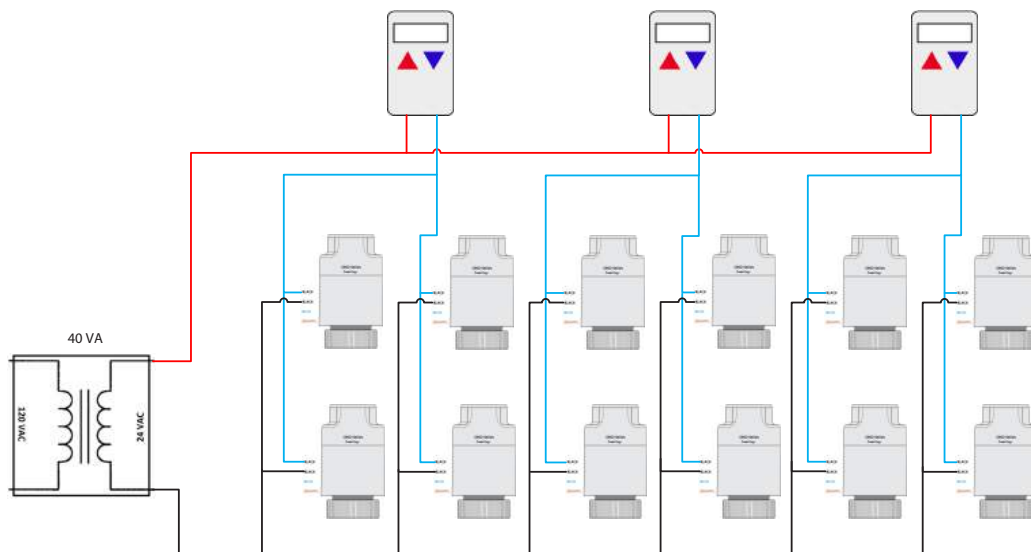

ACCESSORIES



Replacement balance/flow meter fits 668S1 series manifold.
Flow meter scale: ¼ — 2 gpm.

Code	Description	Lbs	USD
F69600	Fits 668S1 supply manifold	0.2	23.40



Replacement shut-off valve fits 668S1 series manifold.

Code	Description	Lbs	USD
F69590	Fits 668S1 return manifold	0.3	18.70



Replacement balancing valve fits 668 series manifold.

Code	Description	Lbs	USD
F69184	Fits 668 supply manifold	0.2	16.30



Replacement shut-off valve fits 668 & 663 series manifold.

Code	Description	Lbs	USD
69122 CST	Fits 668 & 663 return manifold	0.3	10.40



Replacement balancing valve for 663 series manifold.

Code	Description	Lbs	USD
R69176	Fits 663 supply manifold	0.3	16.00



NA669

Flow meter fits manifolds.
Max: temperature: 180°F (669050).
Max: temperature: 210°F (NA669 series).
¼" straight male x ¼" straight female connections.

Code	Description	Lbs	USD
669050	1 — 4 LPM	0.4	27.60
NA669150	¼ — 1 GPM High Temp.	0.3	27.60
NA669250	½ — 2 GPM High Temp.	0.3	27.60



White replacement knob fits 663 and 668S1 series manifolds.

Code	Description	Lbs	USD
449000	Knob	0.5	8.10

5020



Replacement air vent fits radiant manifolds.
Brass body.
Hygroscopic safety air vent cap.
Max. working pressure: 150 psi
Max discharge pressure: 32 psi
Max. working temperature: 250°F.

Code	Description	Lbs	USD
502043 CST	½" straight thread	0.6	19.60



Plastic replacement/test cap fits 5020 series.

Code	Description	Lbs	USD
R56214	Vent cap	0.1	1.70

675



Snap-on thermometer directly to PEX, PEX-AL-PEX and copper piping.
Box of 10 comes with 1 syringe of thermo conductive paste.

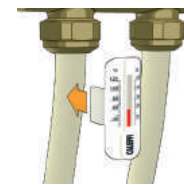

Code	Description	Lbs	USD
675900A	¾" & 5/8" PEX & ½" copper	0.2	8.70
R69413	Syringe of thermo conductive paste	0.1	6.10

688



Temperature gauge with well pocket fitting for inserting into manifold ball valves.
Working Temperature range: 30—210°F.
Face dial diameter: 2".

Code	Description	Lbs	USD
R39591	Replacement gauge	0.1	21.20
688003A	Gauge with pocket well	0.2	32.40
NA10498	Replacement pocket well, low lead	0.1	3.20
F67037	O-ring fits NA10498	0.1	0.70

CUTTING-EDGE INNOVATION IN TEMPERATURE MIXING



Caleffi mixing valves lead the way. From 3/8" under-sink scald protection valves to 3" flanged digital master mixing valves, we have a full offering for residential and commercial applications. Over 50 years of innovation and global experience assure high quality and proven reliability. A wide selection of double union connection types work with copper, iron, steel and non-metallic pipes. The valves comply with the necessary standards and codes for the U.S. and Canada. **CALEFFI GUARANTEED.**



MIXING VALVES FOR PLUMBING AND HYDRONICS

This diagram is for illustration purposes only

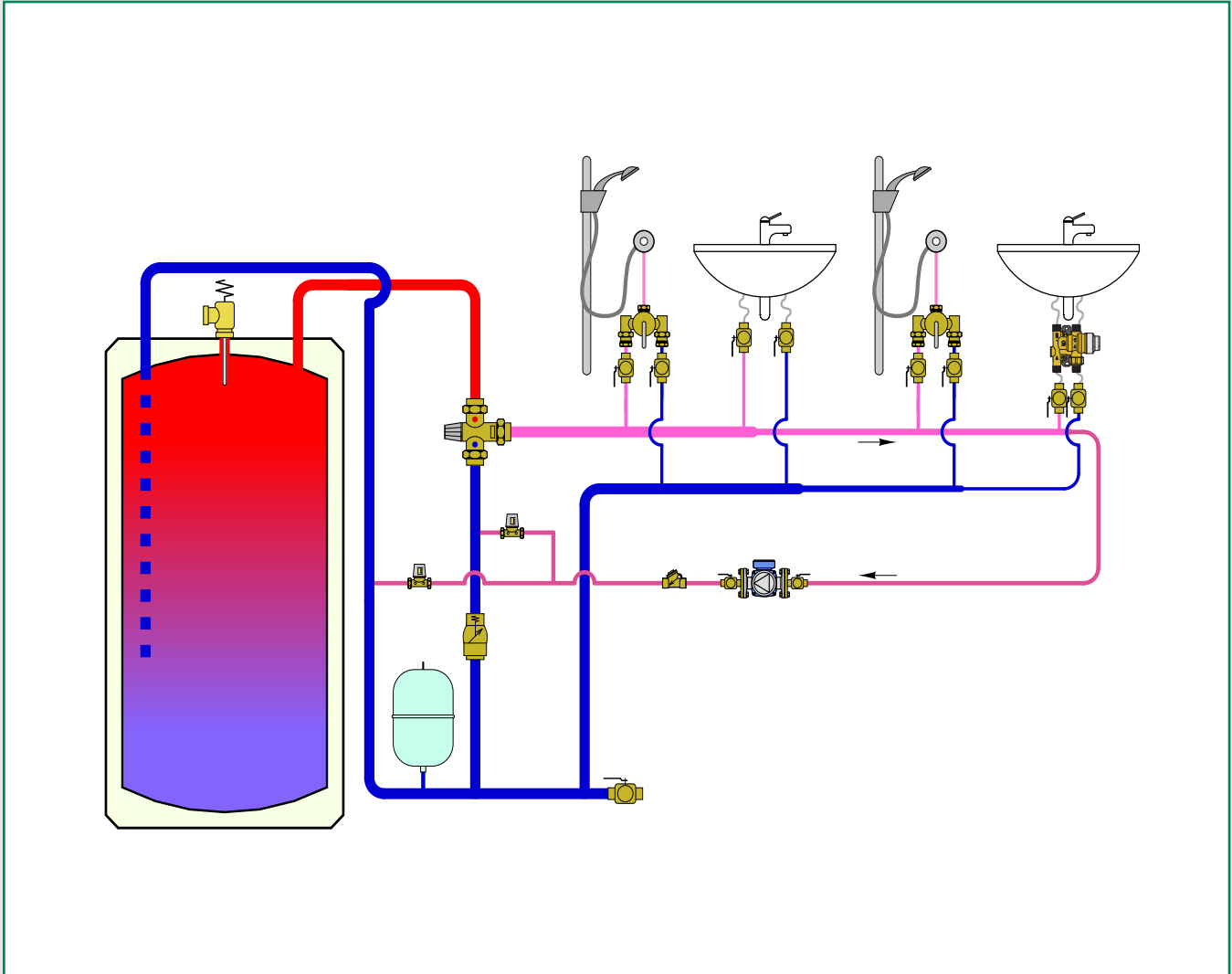

6A

PRODUCTS INCLUDED IN SECTION

- Thermostatic mixing valves for plumbing and hydronics
- High flow thermostatic mixing valves for plumbing and hydronics
- Scald protection thermostatic mixing valves for plumbing
- High/low thermostatic mixing valve for plumbing
- Mixing valves for centralized hydronic systems
- Electronic mixing valve for plumbing
- Thermostatic mixing valve kit for domestic water heaters

THERMOSTATIC MIXING VALVES FOR PLUMBING AND HYDRONICS



**521
MixCal™**

Adjustable thermostatic mixing valve for point of distribution in domestic water systems and radiant hydronic heating systems. Low-lead brass body. Locking set point knob. Max. working pressure: 200 psi. Max. inlet temperature: 200°F. Adjustable range: 85 – 150°F. Min. flow for optimum performance: 1.0 gpm. (0 gpm with recirculation) Max flow for optimum performance 14 gpm.



**521
MixCal™ with gauge**

Adjustable thermostatic mixing valve for point of distribution in domestic water systems and radiant hydronic heating systems. Low-lead brass body. Locking set point knob. Max. working pressure: 200 psi. Max. inlet temperature: 200°F. Adjustable range: 85 – 150°F. Min. flow for optimum performance: 1.0 gpm. (0 gpm with recirculation) Max flow for optimum performance 14 gpm. Optional Gauge scale: 30 – 210°F.

Code	Description	Cv	Lbs	USD
521409A	½" sweat union	3	2.4	160.00
521409AC	½" sweat union, check valves	3	2.4	177.00
521400A	½" NPT male union	3	2.4	167.00
521400AC	½" NPT male union, check valves	3	2.4	184.00
521406A	½" Press union	3	2.4	170.00
521407A	½" PEX crimp union	3	2.4	160.00
521407AC	½" PEX crimp union, check valves	3	2.9	177.00
521408A	½" PEX expansion union	3	2.4	160.00
521408AC	½" PEX expansion union, check valves	3	2.9	177.00
521509A	¾" sweat union	3	2.4	167.00
521509AC	¾" sweat union, check valves	3	2.4	192.00
521500A	¾" NPT male union	3	2.4	175.00
521500AC	¾" NPT male union, check valves	3	2.4	199.00
521506A	¾" Press union	3	2.4	175.00
521506AC	¾" Press union, check valves	3	2.5	216.00
521507A	¾" PEX crimp union	3	2.4	167.00
521507AC	¾" PEX crimp union, check valves	3	2.9	192.00
521508A	¾" PEX expansion union	3	2.4	167.00
521508AC	¾" PEX expansion union, check valves	3	2.9	192.00
521609A	1" sweat union	3	2.4	199.00
521609AC	1" sweat union, check valves	3	2.4	223.00
521600A	1" NPT male union	3	2.4	207.00
521600AC	1" NPT male union, check valves	3	2.4	231.00
521606A	1" Press union	3	2.6	211.00
521606AC	1" Press union, check valves NEW	3	3.1	230.00
521607A	1" PEX crimp union	3	2.4	199.00
521607AC	1" PEX crimp union, check valves	3	2.9	223.00
521608A	1" PEX expansion union	3	2.4	199.00
521608AC	1" PEX expansion union, check valves	3	2.9	223.00

Code	Description	Cv	Lbs	USD
521419A	½" sweat union	3	2.9	190.00
521419AC	½" sweat union, check valves	3	2.9	206.00
521410A	½" NPT male union	3	2.9	197.00
521410AC	½" NPT male union, check valves	3	2.9	213.00
521416A	½" Press union	3	2.9	200.00
521417A	½" PEX crimp union	3	2.5	190.00
521417AC	½" PEX crimp union, checks	3	2.9	206.00
521418A	½" PEX expansion union	3	2.5	190.00
521418AC	½" PEX expansion union, checks	3	2.9	206.00
521519A	¾" sweat union	3	2.9	197.00
521519AC	¾" sweat union, check valves	3	2.9	221.00
521510A	¾" NPT male union	3	2.9	205.00
521510AC	¾" NPT male union, check valves	3	2.9	228.00
521516A	¾" Press union	3	2.9	205.00
521516AC	¾" Press union checks	3	3	246.00
521517A	¾" PEX crimp union	3	2.5	197.00
521517AC	¾" PEX crimp union, checks	3	2.9	221.00
521518A	¾" PEX expansion union	3	2.5	197.00
521518AC	¾" PEX expansion union, checks	3	2.9	221.00
521619A	1" sweat union	3	2.9	230.00
521619AC	1" sweat union, check valves	3	2.9	253.00
521610A	1" NPT male union	3	2.9	238.00
521610AC	1" NPT male union, check valves	3	2.9	261.00
521616A	1" Press union	3	3.1	242.00
521616AC	1" Press union, check valves NEW	3	3.5	260.00
521617A	1" PEX crimp union	3	2.5	230.00
521617AC	1" PEX crimp union, checks	3	2.9	253.00
521618A	1" PEX expansion union	3	2.5	230.00
521618AC	1" PEX expansion union, checks	3	2.9	253.00

Meets requirements of NSF/ANSI 372-2011. Complies with ASSE 1017, CSA B125.3, UPC, IPC, Low Lead Laws and listed by ICC-ES for use in accordance with the U.S. and Canadian plumbing codes.

THERMOSTATIC MIXING VALVES FOR PLUMBING AND HYDRONICS



Point of distribution mixed temperature gauge adaptor fits 1" male union thread mixing valves.
Removable gauge fits into pocket well.
Gauge scale: 30–210°F.
Gauge accuracy: ± 6°F.
Gauge dial: 2" diameter.
Certified: Low-lead brass.



521 MixCal™ Body

Replacement body (1/2", 3/4", 1" valve).
See fitting selection table in Section 8.

Code	Description	Lbs	USD
NA10328	½" sweat with gauge	0.4	47.50
NA10056	¾" sweat with gauge	0.4	52.20
NA10058	1" sweat with gauge	0.4	57.30
NA10358	1" union thread with gauge	0.4	29.90
688003A	Replacement gauge with pocket well	0.5	32.40
R39591	Replacement gauge	0.1	21.20
NA10498	Pocket well, plated	0.1	3.20

Code	Description	Cv	Lbs	USD
521101A	1" union body	3	1.9	123.00

Construction details

Anti-scale materials The material used in the construction of the Caleffi MixCal 521 series thermostatic mixing valve reduces jamming caused by lime scale deposits. All the working parts such as shutter, seats and slide guides are made of a special anti-scale material, with a low friction coefficient, assuring long term performance.

Temperature setting and locking The control knob permits temperature setting between minimum and maximum in one turn (360°). It also has a tamper-proof system to lock the temperature at the set value.

Application diagram

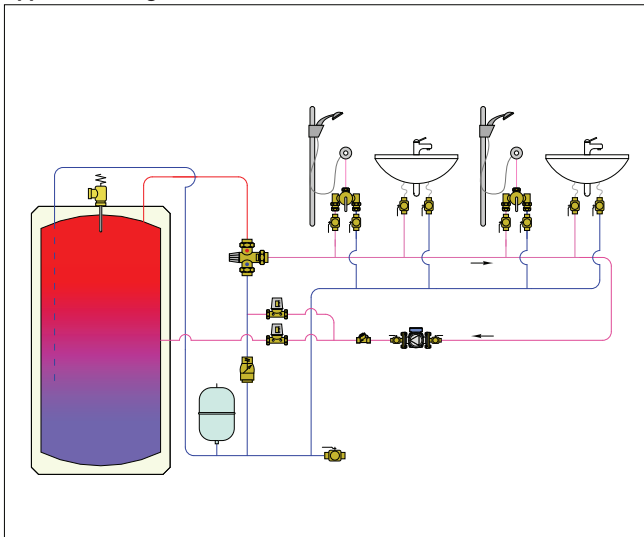

Characteristic components

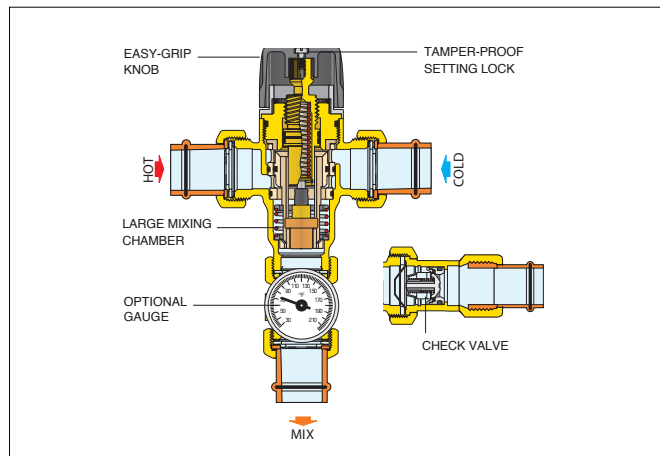

ACCESSORIES



Replacement check valves for 521 (AC models).



Conical inlet filter for 521 mixing valves.

Code	Description	Lbs	USD
NA10405	Repl. check for 521 PEX, press fittings	0.1	2.00
R39204	Repl. check for 521 sweat, NPT fittings	0.1	2.80

Code	Description	Lbs	USD
F52429	Conical filter	0.1	4.10

THERMOSTATIC MIXING VALVES FOR PLUMBING AND HYDRONICS



520
AngleMix™ with gauge

Adjustment temperature range: 95°F — 150°F.
 Max. body pressure rating (static): 150 psi.
 Max. working pressure (dynamic): 75 psi.
 Max. inlet temperature: 195°F.
 Gauge scale: 30—210°F.
 Min/Max flow: 0.5 gpm minimum, 9 gpm. maximum (1/2" and 3/4" valves); 1.0 gpm. minimum, 16 gpm maximum (1" valves).

Code	Description	Cv	Lbs	USD
520419A	1/2" sweat union	NEW 2	1.7	190.00
520419AC	1/2" sweat union, checks	NEW 2	1.8	206.00
520410A	1/2" NPT male union	NEW 2	1.7	197.00
520410AC	1/2" NPT male union, checks	NEW 2	1.8	213.00
520416A	1/2" press union	NEW 2	1.8	200.00
520519A	3/4" sweat union	2	2	197.00
520519AC	3/4" sweat union, checks	2	2.1	221.00
520510A	3/4" NPT male union	NEW 2	2	205.00
520510AC	3/4" NPT male union, checks	NEW 2	2.1	228.00
520516A	3/4" press union	2	2	205.00
520516AC	3/4" press union, checks	2	2.1	246.00
520619A	1" sweat union	NEW 3.5	3.7	275.00
520619AC	1" sweat union, check valves	NEW 3.5	3.8	298.00
520610A	1" NPT male union	NEW 3.5	3.9	283.00
520610AC	1" NPT male union, check valve	NEW 3.5	4	306.00
520616A	1" press union	NEW 3.5	3.7	287.00
520616AC	1" press union, check valves	NEW 3.5	3.9	310.00

Meets requirements of NSF/ANSI 372-2011. Complies with ASSE 1017, CSA B125.3, UPC, IPC, Low Lead Laws and listed by ICC-ES for use in accordance with the U.S. and Canadian plumbing codes.

Application diagram

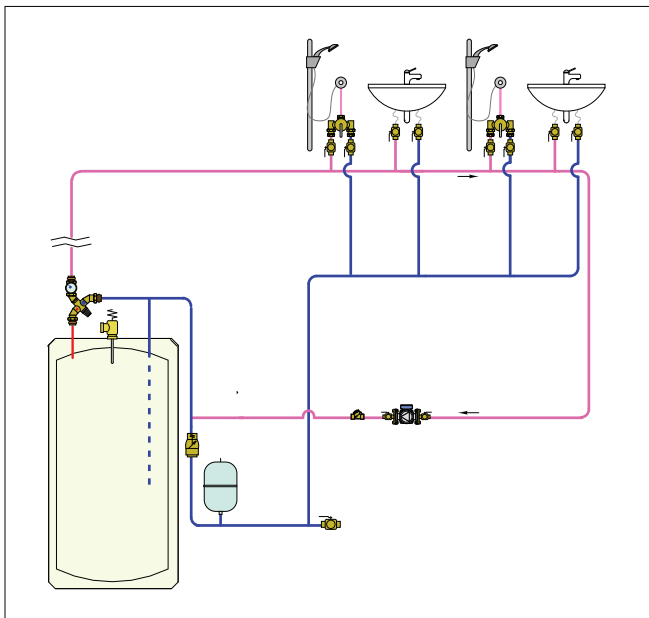

Construction details

Anti-scale materials The material used in the construction of the Caleffi AngleMix 520 series thermostatic mixing valve reduces jamming caused by lime deposits. All the working parts such as shutter, seats and slide guides are made of a special anti-scale polymer material, with a low friction coefficient, assuring long term performance.

Temperature setting and locking The control knob permits temperature setting between minimum and maximum in one turn (360°). It also has a tamper-proof system to lock the temperature at the set value.

Thermal shut-off In the event of accidental cold water supply failure, the shutter seals off the hot water passage, thus preventing the delivery of mixed temperature water. This is only guaranteed when there is a minimum temperature difference between the inlet hot water and the mixed temperature water delivery of 18° F. Additionally, the tight closing hot inlet port prevents temperature creep in recirculation applications.

As a convenience, the codes with "AC" suffix are supplied complete with a check valve in the hot and cold inlet ports.

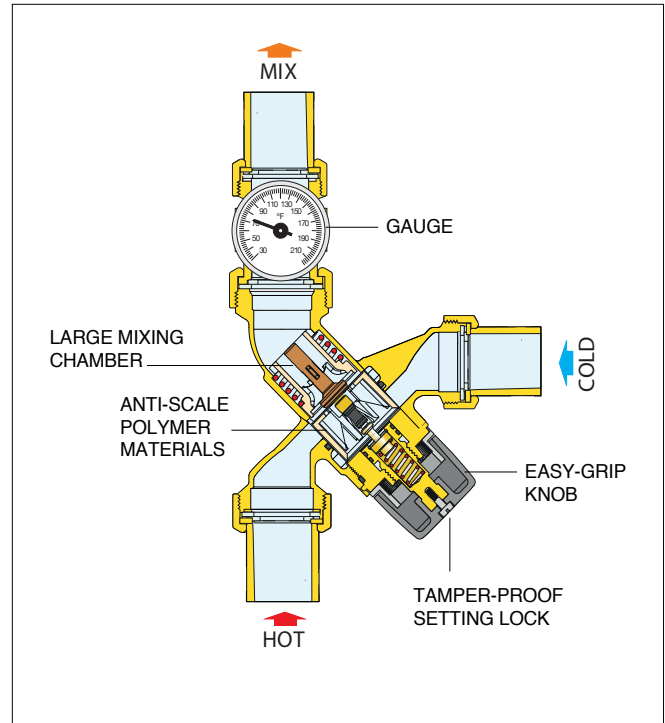

520
AngleMix™ Body

Replacement body.
 See fitting selection table in Section 8.



Code	Description	Cv	Lbs	USD
520051A	1" union body (1/2", 3/4" valves)	2	2	123.00
520061A	1 1/4" union body (1" valves)	NEW 3.5	4	171.00

HIGH FLOW THERMOSTATIC MIXING VALVES FOR PLUMBING AND HYDRONICS

Model 5231 series high flow thermostatic mixing valves for centralized systems are designed to be installed at the domestic water heater (point of distribution). For safety reasons, it is advisable to limit the maximum mixed water temperature to 120°F when anti-scald valves are not installed at point-of-use. 5231 series thermostatic mixing valves can also be used for regulating the flow temperature in radiant panel heating systems, to which it assures a constant and accurate control with ease of installation. Meets requirements of NSF/ANSI 372-2011. Certified to ASSE 1017, CSA B125.3, UPC, IPC, Low Lead Laws and listed by ICC-ES for use in accordance with the U.S. and Canadian plumbing codes.



5231 MixCal+™

Adjustable thermostatic mixing valve for domestic water systems and radiant hydronic systems.
DZR low lead brass body.
Max. working pressure: 200 psi.
Max. inlet temperature: 195°F.
Adjustable range: 95—150°F.

Code	Description	Min - Max Flow (gpm)	Cv	Lbs	USD
523168A	1" sweat union	4.4 to 40	7	7	1,006.00
523160A	1" NPT male union	4.4 to 40	7	7	1,016.00
523166A	1" press union	4.4 to 40	7	7	1,070.00
523178A	1¼" sweat union	4.4 to 40	7.6	7	1,051.00
523176A	1¼" press union	4.4 to 40	7.6	7	1,119.00
523170A	1¼" NPT male union	4.4 to 40	7.6	7	1,099.00
523188A	1½" sweat union	8.8 to 70	13	17	1,580.00
523186A	1½" press union	8.8 to 70	13	17	1,721.00
523180A	1½" NPT male union	8.8 to 70	13	17	1,619.00
523198A	2" sweat union	8.8 to 70	14.2	18	1,661.00
523196A	2" press union	8.8 to 70	14.2	18	1,913.00
523190A	2" NPT male union	8.8 to 70	14.2	18	1,703.00



5231 MixCal+™ Body Sweat

Replacement body includes nuts and washers. See fitting selection table in Section 8.

Code	Description	Min - Max Flow (gpm)	Cv	Lbs	USD
523179A	For 1" and 1¼" sizes	4.4 to 40	7.6	5.0	904.00
523199A	For 1½" and 2" sizes	8.8 to 70	14.2	14.2	1,293.00



5231 MixCal+™ Sweat

Adjustable thermostatic mixing valve for domestic water systems and radiant hydronic systems.
DZR low lead brass body.
Max. working pressure: 200 psi.
Max. inlet temperature: 195°F.
Adjustable range: 95—150°F.
Gauge scale: 30—210°F.
Gauge accuracy: ± 6°F.
Gauge dial: 2" diameter.

Code	Description	Min - Max Flow (gpm)	Cv	Lbs	USD
523177A	1¼" sweat union	4.4 to 40	7.6	9.0	1,130.00



Point of distribution mixed temperature gauge adaptor fits High Flow 5231 series mixing valves.
Removable gauge fits into pocket well.
Gauge scale: 30—210°F.
Gauge accuracy: ± 6°F.
Gauge dial: 2" diameter.
Certified: Low-lead brass.

Code	Description	Lbs	USD
NA10315	1¼" sweat	0.5	115.00
NA10476	1" and 1¼" male x female union	3.0	131.00
NA10461	1½" and 2" male x female union	4.0	227.00
688003A	Replacement gauge with pocket well	0.2	32.40
R39591	Replacement gauge	0.1	21.20



Inlet check valve assembly for installing on inlet union tail pieces of 5231 mixing valves. Stainless steel body. No Lead. Ordered separately, field installed. Assembly examples shown below.



523177A shown with (2) NA10366 523178A shown with (2) NA10366

Code	Description	Lbs	USD
NA10366	Check valve assembly 1" and 1¼"	1.0	50.80
NA10367	Check valve assembly 1½" & 2"	1.5	125.00

SCALD PROTECTION THERMOSTATIC MIXING VALVES FOR PLUMBING



5212 SinkMixer™ 4-way Scald Protection Point-of-use

Thermostatic mixing valve for under sink and under counter applications where the user must be protected from the danger of scalding caused by hot water. Temperature adjustment range: 95—120°F. Cold inlet temperature: Min. 39°F; Max. 85°F. Hot inlet temperature: Min. 120°F; Max. 195°F. Maximum operating differential pressure: Static: 150 psi (10 bar). Dynamic: 70 psi (5 bar). Min. operating differential pressure (dynamic): 1.5 psi (0.1 bar). Min flow for optimum performance 0.35 gpm. Max flow for optimum performance 2.3 gpm. Complies with NSF/ANSI/CAN 61.

Code	Description	Cv	Lbs	USD
521201A	3/8" compression	0.52	1	100.00
521201AP	3/8" compression, plug/fittings NEW	0.52	1.1	102.00



5213 Scald Protection Point-of-Use

Adjustable thermostatic mixing valve for point of use where protected from scalding caused by hot water with locking set point. Complete with check valves on both hot and cold inlets. Low-lead brass body. Max. working pressure: 150 psi. Max. inlet temperature: 185°F. Adjustable range: 85—120°F. Temperature control: ±3°F. Min. flow for optimum performance: 0.5 gpm. Max flow for optimum performance 9 gpm.

Code	Description	Cv	Lbs	USD
521333A	3/8" compression union	2	2	139.00
521347A	1/2" PEX crimp union	2	2	164.00
521348A	1/2" PEX expansion union	2	2	164.00
521342A	1/2" NPT male union	2	2	172.00
521349A	1/2" sweat union	2	2	164.00
521357A	3/4" PEX crimp union	2	2	172.00
521358A	3/4" PEX expansion union	2	2	172.00
521352A	3/4" NPT male union	2	2	179.00
521359A	3/4" sweat union	2	2	172.00
521367A	1" PEX crimp union	2	2	205.00
521368A	1" PEX expansion union	2	2	205.00
521362A	1" NPT male union	2	2	212.00
521369A	1" sweat union	2	2	205.00
521301A*	Replacement body, no fittings	2	1.5	113.00

*See fitting selection table in Section 8.

Meets requirements of NSF/ANSI 372-2011. Complies with ASSE 1070, CSA B125.3, UPC, IPC, Low Lead Laws and listed by ICC-ES for use in accordance with the U.S. and Canadian plumbing codes.



SinkMixer™ Replacement check valve/filter kit. Includes two checks and two filters.

Code	Description	Lbs	USD
F0001270	Replacement check valve/filter kit	0.1	6.00



SinkMixer™ 5-pack plug/nut fitting kit. The cold outlet port plug is for single-pipe mixed water only fixtures.

Code	Description	Lbs	USD
NA10741	5-pack plug/nut fitting kit	0.2	15.00

Construction details SinkMixer™

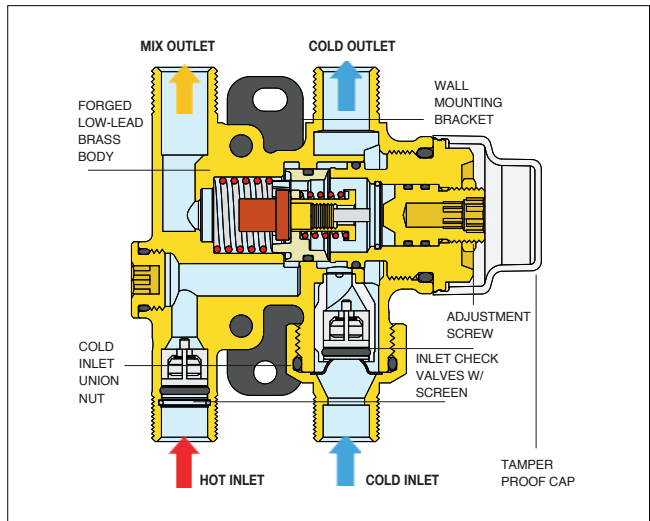

Application diagram SinkMixer™

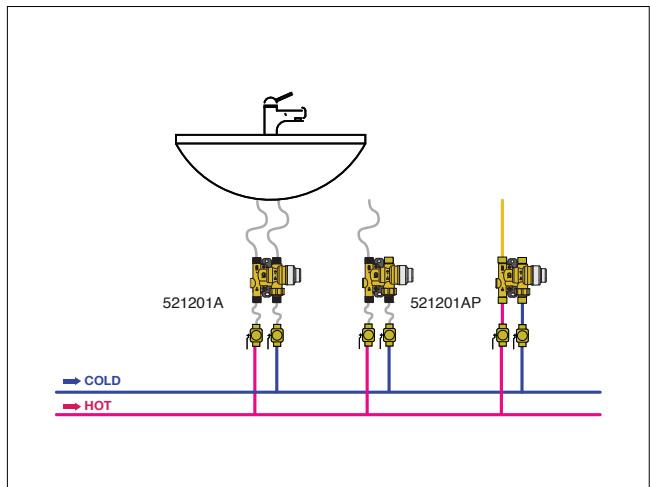

HIGH/LOW THERMOSTATIC MIXING VALVE FOR PLUMBING



**NA523
DELTA 2™**

Adjustable thermostatic high low mixing valve for point of distribution in domestic water systems.
 Low-lead brass valve bodies.
 Locking set point knobs on thermostatic mixing valves.
 Check valves on thermostatic mixing valve cold inlets.
 Locking set point knob on pressure reducing valve.
 Copper connecting tubing, all sweat construction.
 Double union connection on all valves for ease of service.
 Removable ½" NPT threaded outlet thermometer.
 Pre-mounted to strut for easy mounting.

Max. working pressure: 200 psi.
 Max. inlet temperature: 180°F.
 Adjustable range: 95 – 150°F.
 Flow range: 1 to 50 gpm.

Thermostatic mixing valves meet requirements of NSF/ANSI 372-2011 and certified to ASSE 1017, CSA B125.3, UPC, IPC, Low Lead Laws and listed by ICC-ES for use in accordance with the U.S. and Canadian plumbing codes. Pressure reducing valve meets requirements of ASSE 1003, CSA B356, NSF61, NSF/ANSI 372 Low Lead Laws and listed by ICC-ES. Meets codes IPC, IRC & UPC for use in accordance with the U.S. and Canadian plumbing codes.

Code	Description	Lbs	USD
NA52367HL	1" sweat inlets, 1¼" sweat outlet, copper	25	2,592.00
NA10512	Ball valve stems extension kit	0.9	101.00

Function

The NA523 two-stage high low mixing valve system delivers tempered water for a wide range of flows in a single assembly, applicable for institutional and commercial applications such as hotels, nursing homes, hospitals, schools, and so on. The NA523 is furnished assembled and pressure tested with large and small mixing valves along with a pressure reducing valve, to function as one system in providing a broad flow range from 1 gpm to 50 gpm. This one-piece assembly also contains an outlet thermometer, cold water inlet check valves, and shut-off ball valves. The mixing valves are piped in parallel to the hot and cold inlet lines and the pressure reducing valve is piped on the outlet (mixed temperature) side of the larger thermostatic mixing valve. When demand is low, the small thermostatic mixing valve provides the needed water flow. When demand increases, indicated by increasing Delta P (differential pressure) in the system, the pressure reducing valve sees this fall off pressure, and opens to allow flow through the larger thermostatic mixing valve.

Application Diagram

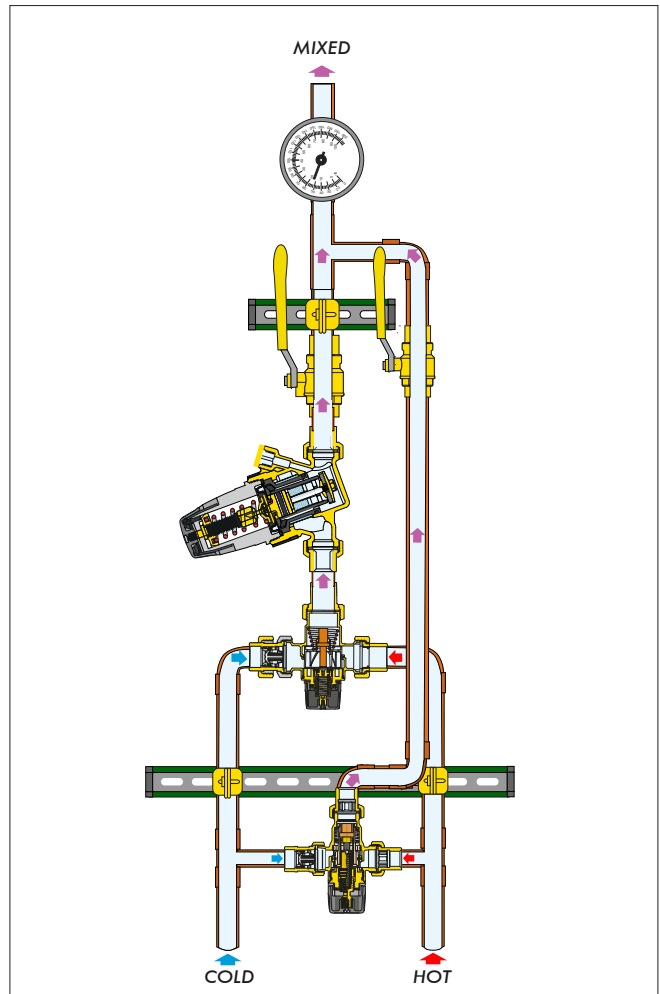
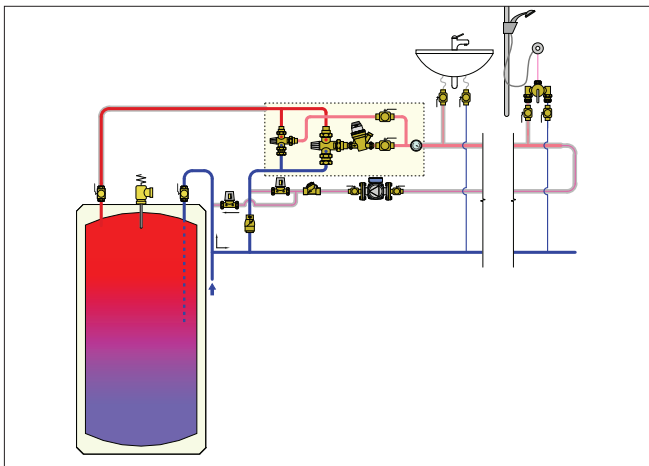

ELECTRONIC MIXING VALVE FOR PLUMBING



6000 LEGIOMIX®

Electronic mixing valve with optional selectable programs for thermal disinfection of hot water recirculation system to kill Legionella bacteria.

- Code number includes:
- three-way ball valve
- 3-wire floating control actuator
- controller/user interface with DIN rail mounting bracket
- mixed outlet temperature sensor/probe
- return temperature sensor/probe
- mixed outlet temperature gauge

Power: 24 VAC +/- 10% - 50/60 Hz - 6 VA.
 115/24 VAC transformer included.
 Adjustment temperature range: 70 — 185°F.
 Disinfection temperature range: 100 — 185°F.
 Max body pressure rating (static): 230 psi.
 Max operating pressure: 150 psi.
 Max. inlet temperature: 212°F.
 Protection class: IP 54 (controller).

Meets requirements of NSF/ANSI 372-2011 and complies with ASSE 1017, CSA B125.3, UPC, IPC, Low Lead Laws and listed by ICC-ES for use in accordance with the U.S. and Canadian plumbing codes. Meets requirements of CSA Z317.1 Special Requirements For Plumbing Installations In Health Care Facilities.

Function

The electronic mixing valve is used in centralized systems that produce and distribute domestic hot water. The LEGIOMIX® electronic mixing valve provides precise temperature control over very low and very high flow rate demand, minimal pressure drop with a ball valve control element, automatic self-cleaning to prevent scale formation and easy-to-use digital interface with data logging, alarming and status indication.

Characteristic components

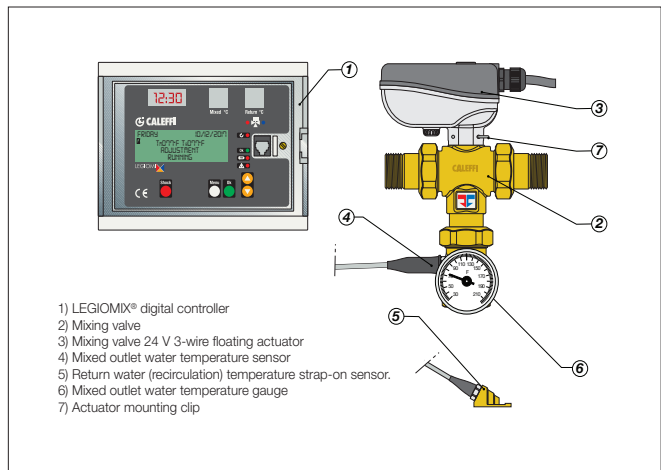

- 1) LEGIOMIX® digital controller
- 2) Mixing valve
- 3) Mixing valve 24 V 3-wire floating actuator
- 4) Mixed outlet water temperature sensor
- 5) Return water (recirculation) temperature strap-on sensor.
- 6) Mixed outlet water temperature gauge
- 7) Actuator mounting clip

Code	Description	Cv	Lbs	USD
600054A	¾" NPT male union	9.7	5.1	2,281.00
600059A	¾" sweat union	9.7	5.1	2,258.00
600056A	¾" press union	9.7	5.1	2,379.00
600064A 001	1" NPT male union, ¾" body NEW	9.7	5.3	2,395.00
600069A 001	1" sweat union, ¾" body NEW	9.7	5.3	2,379.00
600066A 001	1" press union, ¾" body NEW	9.7	5.2	2,469.00
600064A	1" NPT male union	21	7.3	2,508.00
600069A	1" sweat union	21	7.3	2,499.00
600066A	1" press union	21	7.3	2,559.00
600074A	1-1/4" NPT male union	24	8.2	2,586.00
600079A	1¼" sweat union	24	8.2	2,541.00
600076A	1¼" press union	24	8.2	2,604.00
600084A	1½" NPT male union	34	21	2,919.00
600089A	1½" sweat union	34	21	2,884.00
600086A	1½" press union	34	21	3,015.00
600094A	2" NPT male union	48	22	2,999.00
600099A	2" sweat union	48	22	2,958.00
600096A	2" press union	48	22	3,194.00
600060A	2½" ANSI 150 flanges	105	30	10,777.00
600080A	3" ANSI 150 flanges	120	42	11,408.00

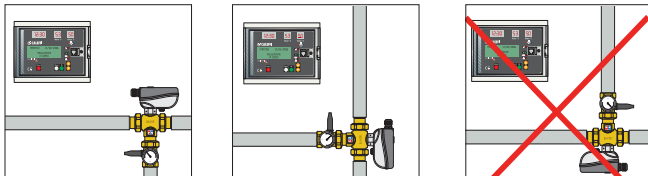

Size	Recommended Flow Rates (gpm/lpm)						
	¾"	1"	1¼"	1½"	2"	2½"	3"
Minimum flow*	2.2 / 8.3	3.1 / 11.7	4.4 / 16.6	6.6 / 25	8.8 / 33.3	17.0 / 64	22.0 / 83.3
Design flow**	27 / 102	58 / 220	66 / 250	93 / 352	131 / 495	288 / 1,090	329 / 1,245
Flow at 20 psid	43 / 172	94 / 356	107 / 405	152 / 575	215 / 814	470 / 1,780	537 / 2,033
Cv	9.7	21	24	34	48	105	120

*To ensure stable operation and ± 3° F accuracy. Minimum flow rate is 0 gpm when recirculation flow rate is greater than or equal to the valve size minimum flow rating.
 **Suggested maximum flow rate for optimum modulating control (at 7.5 psid pressure drop).

ACCESSORIES AND REPLACEMENT



Replacement mixed temp sensor.

Code	Description	Lbs	USD
F69807	Fits 1" and 1¼" valve	1.0	53.00



Replacement mixed temp sensor.

Code	Description	Lbs	USD
F69804	Fits 1½" and 2" valve	1.0	75.50



Replacement recirculation sensor.

Code	Description	Lbs	USD
F69591	Replacement recirculation sensor	1.0	67.30



Replacement controller.

Code	Description	Lbs	USD
F000962	Replacement controller	1.5	1,513.00



Replacement actuator.

Code	Description	Lbs	USD
645114	Replacement actuator	1.0	378.00



Replacement transformer.

Code	Description	Lbs	USD
NA10703	Foot-mount transformer 50 VA	3	57.30
NA10759	Plug-in transformer 20 VA NEW	1	32.50



Replacement temp gauge.

Code	Description	Lbs	USD
R19101	Replacement temp gauge	0.3	18.40



Modbus-to-BACnet gateway
Converts LEGIOMIX® controller Modbus (RS-485 serial) output communication to BACnet IP or MSTP communication.

Code	Description	Lbs	USD
755052	Modbus-to-BACnet gateway	1.2	1,687.00



Inlet check valve assembly for installing on 6000 Series valve body (if required). Stainless steel body. No Lead. Ordered separately, field installed. 2 required per valve.

Code	Description	Lbs	USD
NA10366	Check valve assembly 1" and 1¼"	1.0	50.80
NA10367	Check valve assembly 1½" & 2"	1.5	125.00



Replacement body includes gauge adapter assembly.
See fitting selection table in Section 8.

Code	Description	Lbs	USD
NA10758	Body, gauge adapter (¾" valve) NEW		388.00
NA10615	Body, gauge adapter (1", 1¼" valves)		437.00
NA10616	Body, gauge adapter (1½", 2" valves)		641.00



Replacement controller battery.



Code	Description	Lbs	USD
F69888	Replacement controller battery	0.1	38.00

ELECTRONIC MIXING VALVE FOR PLUMBING



6000
LEGIOMIX® Station

Electronic mixing valve with optional selectable programs for thermal disinfection of hot water recirculation system to kill Legionella bacteria, in a packaged wall mount configuration.

Station assembly includes pre-piped 3-way mixing valve with union connections, serviceable check valves, a recirculation connection and isolation valves for fast and simple installation, all mounted on welded, powder-coat painted steel strut. The LEGIOMIX® controller/user interface with DIN rail mounting bracket is pre-mounted and pre-wired and includes a return water temperature sensor. Simply wall mount the assembly, hook up the hot and cold water supplies, mixed outlet, recirculation return water. Plug in 120/24 VAC transformer with 20 ft cable included.

Code	Description	Cv	Lbs	USD
600066AS	1" copper wall-mount station	7.8	130	7,376.00
600076AS	1¼" copper wall-mount station	9	148	8,382.00
600086AS	1½" copper wall-mount station	20	219	10,608.00
600096AS	2" copper wall-mount station	38	248	12,041.00
600060AS	2½" copper wall-mount station NEW	43	250	13,770.00

Construction details

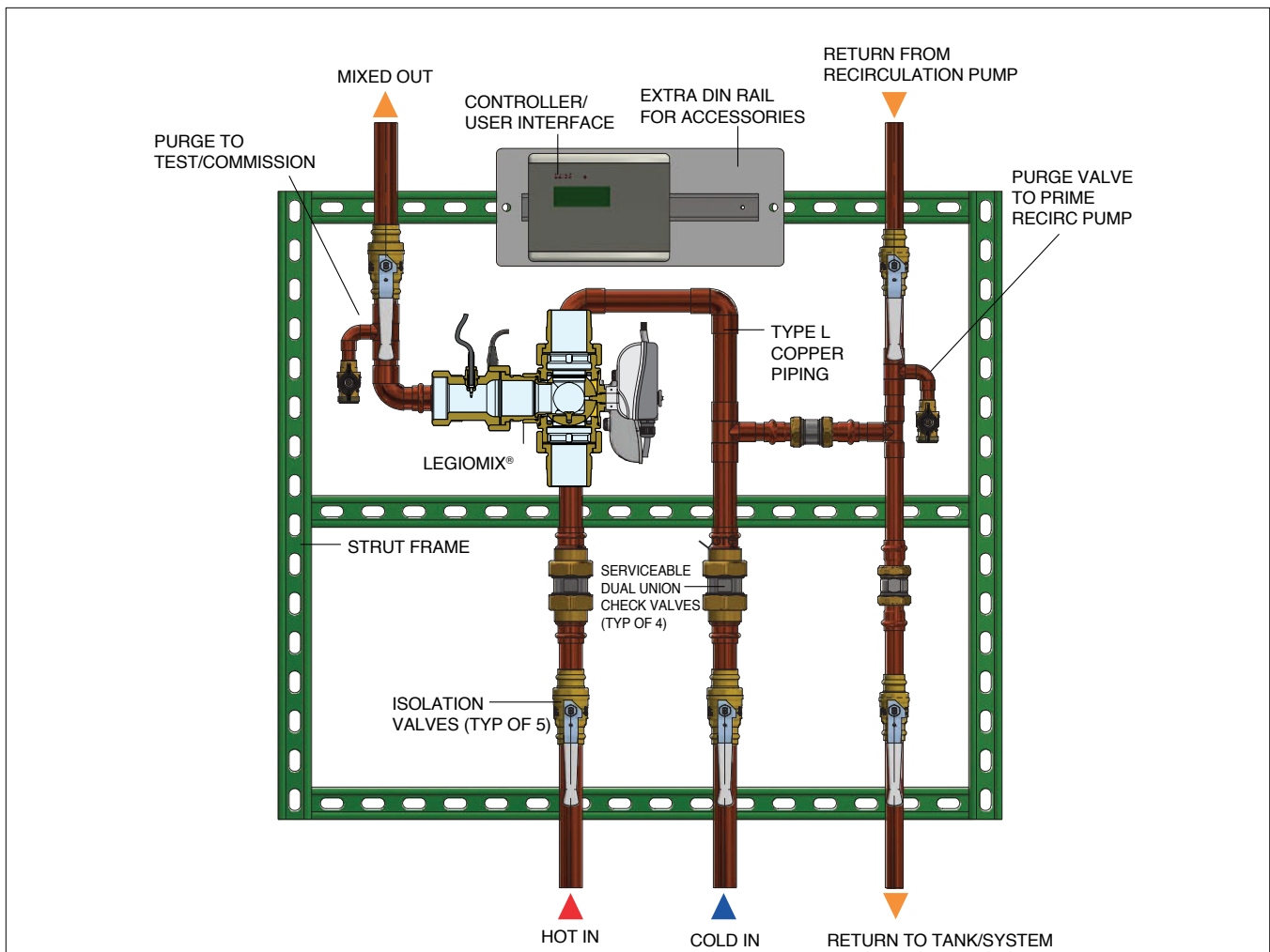

THERMOSTATIC MIXING VALVE KIT FOR DOMESTIC WATER HEATERS



520 TankMixer™

Adjustment temperature range: 95°F - 150°F.
 Max. working pressure (static): 150 psi.
 Max. working pressure (dynamic): 75 psi.
 Max. inlet temperature: 195°F.
 Minimum flow for optimum performance: 0.5 GPM (0 GPM with recirculation).
 Max flow for optimum performance: 9 gpm.
 Tank: 3/4" NPT female union connections.
 System: 3/4" NPT M, press or sweat union connections.



520 TankMixer™ with gauge

Adjustment temperature range: 95°F - 150°F.
 Max. working pressure (static): 150 psi.
 Max. working pressure (dynamic): 75 psi.
 Max. inlet temperature: 195°F.
 Gauge scale: 30—210°F.
 Gauge accuracy: ± 6°F.
 Gauge dial: 2" diameter.
 Minimum flow for optimum performance: 0.5 GPM (0 GPM with recirculation).
 Max flow for optimum performance: 9 gpm.
 Tank: 3/4" NPT female union connections.
 System: 3/4" NPT M, press or sweat union connections.

Code	Description	Cv	Lbs	USD
520500AX	3/4" NPT male union system connections	2	2.4	230.00
520506AX	3/4" press union system connections	2	2.4	262.00
520509AX	3/4" sweat union system connections	2	2.4	222.00

Code	Description	Cv	Lbs	USD
520510AX	3/4" NPT male union system connections	2	2.9	262.00
520516AX	3/4" press union system connections	2	2.9	295.00
520519AX	3/4" sweat union system connections	2	2.9	254.00



520 TankMixer™ Body

Replacement body.
 See fitting section table in Section 8.

Code	Description	Cv	Lbs	USD
520051A	1" male union connection	2	2.0	123.00

Construction details

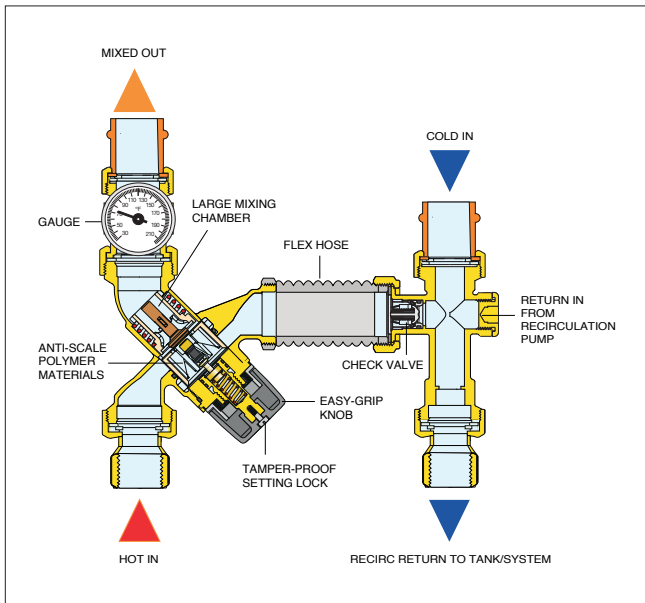

Application diagram

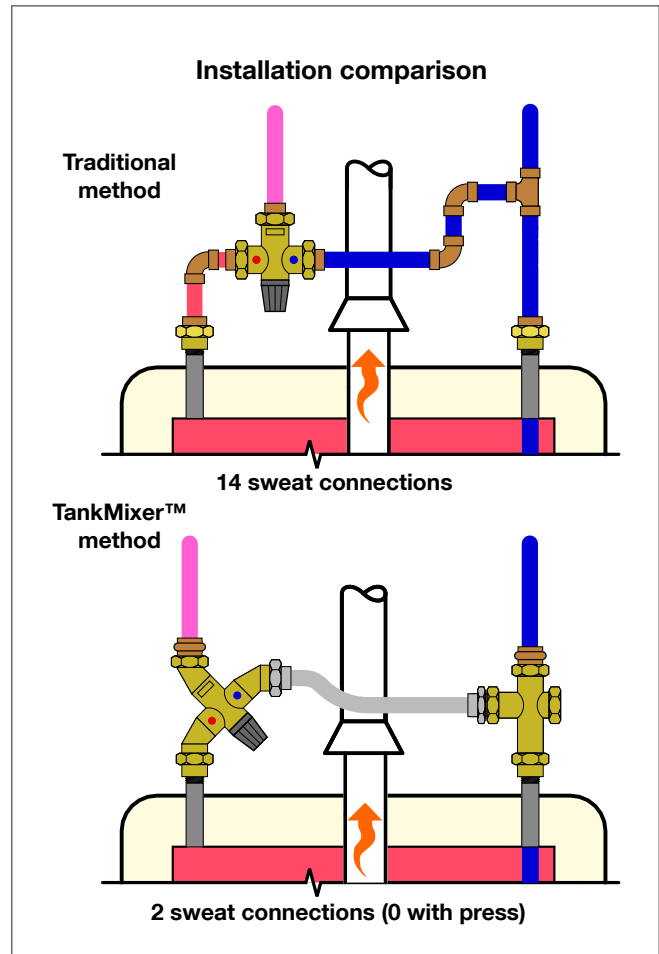

Meets requirements of NSF/ANSI 372-2011. Certified to ASSE 1017, CSA B125.3, UPC, IPC, Low Lead Laws and listed by ICC-ES for use in accordance with the U.S. and Canadian plumbing codes.

SET IT AND FORGET IT

NO BALANCING TOOLS REQUIRED



The ThermoSetter™ thermal balancing valve maintains precise temperature in recirculation return piping using state-of-the-art modulating control. Setup is simple and safe with an easy-to-read, lockable temperature adjustment dial. The integral drywell is versatile, suitable for a local slide-in temperature gauge or remote sensor bulb. Models with bypass cartridges are available for projects that are designed for thermal disinfection to control Legionella bacteria. **CALEFFI GUARANTEED.**



BALANCING VALVES FOR PLUMBING AND HYDRONICS

This diagram is for illustration purposes only

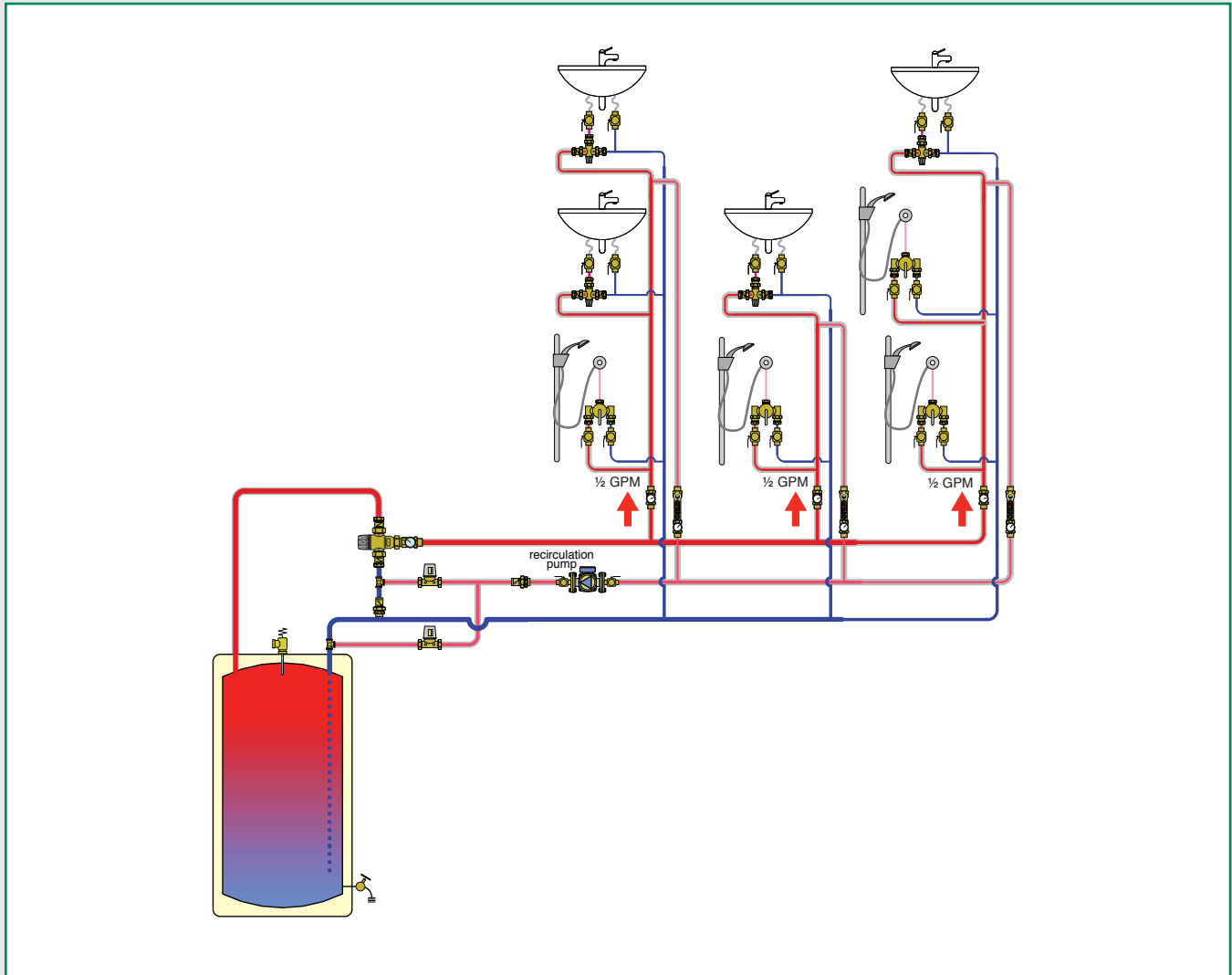

PRODUCTS INCLUDED IN SECTION

- Static balancing valves with flowmeter for plumbing
- Static balancing valves with flowmeter for hydronics
- Thermal balancing valves for plumbing
- Static balancing valves, fixed orifice, for plumbing and hydronics
- Static balancing valves, variable orifice, for plumbing and hydronics
- Dynamic balancing valves for plumbing and hydronics
- Y-strainer with ball valves for hydronics

STATIC BALANCING VALVES WITH FLOWMETER FOR PLUMBING



132 QuickSetter+™

Balancing valve with flow meter.
Direct reading of flow rate.
DZR low-lead brass.
Inlet flow check valve.
2" diameter temperature gauge, optional.
Gauge scale: 30 – 210°F.
Gauge accuracy: ± 6°F.
Complies with NSF/ANSI 372-2000, low lead laws, for use in accordance with the U.S. and Canadian plumbing codes.

Without temperature gauge:

Code	Description	Flow scale (gpm)	Lbs	USD
132434AFC	1/2" PEX crimp union	0.5–1.75	1.8	212.00
132432AFC	1/2" PEX expansion union	0.5–1.75	1.8	212.00
132439AFC	1/2" sweat union	0.5–1.75	2.0	212.00
132534AFC	3/4" PEX crimp union	0.5–1.75	2.0	221.00
132532AFC	3/4" PEX expansion union	0.5–1.75	2.0	221.00
132536AFC	3/4" press union	0.5–1.75	1.8	235.00
132539AFC	3/4" sweat union	0.5–1.75	1.8	221.00
132634AFC	1" PEX crimp union	0.5–1.75	2.2	255.00
132632AFC	1" PEX expansion union	0.5–1.75	2.2	255.00
132636AFC	1" press union	NEW 0.5–1.75	2.2	270.00
132639AFC	1" sweat union	0.5–1.75	2.4	244.00
132454AFC	1/2" PEX crimp union	2.0–7.0	1.8	212.00
132452AFC	1/2" PEX expansion union	2.0–7.0	1.8	212.00
132459AFC	1/2" sweat union	2.0–7.0	2.0	212.00
132554AFC	3/4" PEX crimp union	2.0–7.0	2.0	221.00
132552AFC	3/4" PEX expansion union	2.0–7.0	2.0	221.00
132556AFC	3/4" press union	2.0–7.0	1.8	235.00
132559AFC	3/4" sweat union	2.0–7.0	1.8	221.00
132654AFC	1" PEX crimp union	2.0–7.0	2.2	255.00
132652AFC	1" PEX expansion union	2.0–7.0	2.2	255.00
132656AFC	1" press union	NEW 2.0–7.0	2.2	270.00
132659AFC	1" sweat union	2.0–7.0	2.4	244.00

With temperature gauge:

Code	Description	Flow scale (gpm)	Lbs	USD
132435AFC	1/2" PEX crimp union	0.5–1.75	2.2	243.00
132433AFC	1/2" PEX expansion union	0.5–1.75	2.2	243.00
132438AFC	1/2" sweat union	0.5–1.75	2.4	243.00
132537AFC	3/4" press union	0.5–1.75	2.2	266.00
132535AFC	3/4" PEX crimp union	0.5–1.75	2.4	252.00
132533AFC	3/4" PEX expansion union	0.5–1.75	2.4	252.00
132538AFC	3/4" sweat union	0.5–1.75	2.2	252.00
132635AFC	1" PEX crimp union	0.5–1.75	2.6	286.00
132633AFC	1" PEX expansion union	0.5–1.75	2.6	286.00
132637AFC	1" press union	NEW 0.5–1.75	2.6	300.00
132638AFC	1" sweat union	0.5–1.75	2.8	273.00
132455AFC	1/2" PEX crimp union	2.0–7.0	2.2	243.00
132453AFC	1/2" PEX expansion union	2.0–7.0	2.2	243.00
132458AFC	1/2" sweat union	2.0–7.0	2.4	243.00
132555AFC	3/4" PEX crimp union	2.0–7.0	2.4	252.00
132553AFC	3/4" PEX expansion union	2.0–7.0	2.4	252.00
132557AFC	3/4" press union	2.0–7.0	2.2	266.00
132558AFC	3/4" sweat union	2.0–7.0	2.2	252.00
132655AFC	1" PEX crimp union	2.0–7.0	2.6	286.00
132653AFC	1" PEX expansion union	2.0–7.0	2.6	286.00
132657AFC	1" press union	NEW 2.0–7.0	2.6	300.00
132658AFC	1" sweat union	2.0–7.0	2.8	273.00

Connection size	Flow rate (gpm)	Fully open Cv
1/2"	0.5 - 1.75	1.0
3/4"	0.5 - 1.75	1.0
1"	0.5 - 1.75	1.0
1/2"	2.0 - 7.0	6.3
3/4"	2.0 - 7.0	6.3
1"	2.0 - 7.0	6.3

ACCESSORIES

NEW



Isolation ball valve.
Low lead MxF union fits 1" valves between body and tailpiece.

Code	Description	Lbs	USD
290030	Isolation ball valve 1" M x 1" F union	1	35.00



Replacement body.
See fitting section table in Section 8.

Code	Description	Lbs	USD
132637	0.5 - 1.75 GPM	1	168.00
132657	2.0 - 7.0 GPM	1	177.00



QuickSetter™ Insulation sleeve for valve and fitting on each end.

Code	Description	Lbs	USD
F0000926	For models with temperature gauge	0.1	33.90
112001	For models without temperature gauge	0.1	33.50



Replacement flow meter.

Code	Description	Lbs	USD
F0000940	Replacement flowmeter 0.5 to 1.75 GPM	0.2	93.30
F0000941	Replacement flowmeter 2.0 to 7.0 GPM	0.2	93.30
F19346	Replacement by-pass valve stem*	0.2	34.00

*With operating ring

STATIC BALANCING VALVES WITH FLOWMETER FOR HYDRONICS



132 QuickSetter™

Balancing valve with flow meter.
 Direct reading of flow rate.
 No sight gauge clouding or scaling.
 Brass valve body and flow meter.
 With insulation.
 Max. working pressure: 150 psi.
 Temperature range: 14–230°F.
 Max. percentage of glycol: 50%.

Code	Description	Flow scale (gpm)	Lbs	USD
132432A	½" FNPT	0.5–1.75	2.0	168.00
132436A	½" press	NEW 0.5 - 1.75	2.2	190.00
132552A	¾" FNPT	2.0–7.0	1.8	181.00
132556A	¾" press	NEW 2.0–7.1	2.0	204.00
132662A	1" FNPT	3.0–10.0	2.4	211.00
132666A	1" press	NEW 3.0–10.0	2.4	238.00
132772A	1¼" FNPT	5.0–19.0	2.8	281.00
132776A	1¼" press	NEW 5.0–19.0	2.8	316.00
132882A	1½" FNPT	8.0–32.0	3.4	333.00
132886A	1½" press	NEW 8.0–32.0	3.4	375.00
132992A	2" FNPT	12.0–50.0	4.4	407.00
132996A	2" press	NEW 12.0–50.0	4.4	459.00



132 QuickSetter™

Balancing valve with flow meter.
 Direct reading of flow rate.
 ANSI 125 flanged cast iron body.
 Brass flow meter.
 Max. working pressure: 150 psi.
 Temperature range: 14–230°F.
 Max. percentage of glycol: 50%.

Code	Description	Flow scale (gpm)	Lbs	USD
132060A	2½" ANSI flange	30–105	35	1,005.00
132080A	3" ANSI flange	38–148	62	1,341.00
132100A	4" ANSI flange	55–210	67	2,047.00



Replacement flow meter.

Code	Description	Lbs	USD
F0000940	Replacement flowmeter 0.5 to 1.75 GPM	0.2	93.30
F0000941	Replacement flowmeter 2.0 to 7.0 GPM	0.2	93.30
F0000942	Replacement flowmeter 3.0 to 10 GPM	0.2	93.30
F0000943	Replacement flowmeter 5.0 to 19 GPM	0.2	97.80
F0000944	Replacement flowmeter 8.0 to 32 GPM	0.2	97.80
F0000945	Replacement flowmeter 12 to 50 GPM	0.2	97.80
F0000946	Replacement flowmeter 30 to 105GPM	0.2	103.00
F0000947	Replacement flowmeter 38 to 148 GPM	0.2	103.00
F0000948	Replacement flowmeter 55 to 210 GPM	0.2	103.00
F19346	Replacement by-pass valve stem*	0.2	34.00

*With operating ring

Operating principle

The balancing valve is a hydraulic device that controls the flow rate of the heating/cooling transfer fluid. The control mechanism is a ball valve (1), operated by a control stem (2). The flow rate is manually and properly set by use of the convenient onboard flow meter (3) housed in a bypass circuit on the valve body. This circuit is automatically shut off during normal operation. The flow rate is indicated by a metal ball (4) sliding inside a transparent channel (5) with an integral graduated scale (6).

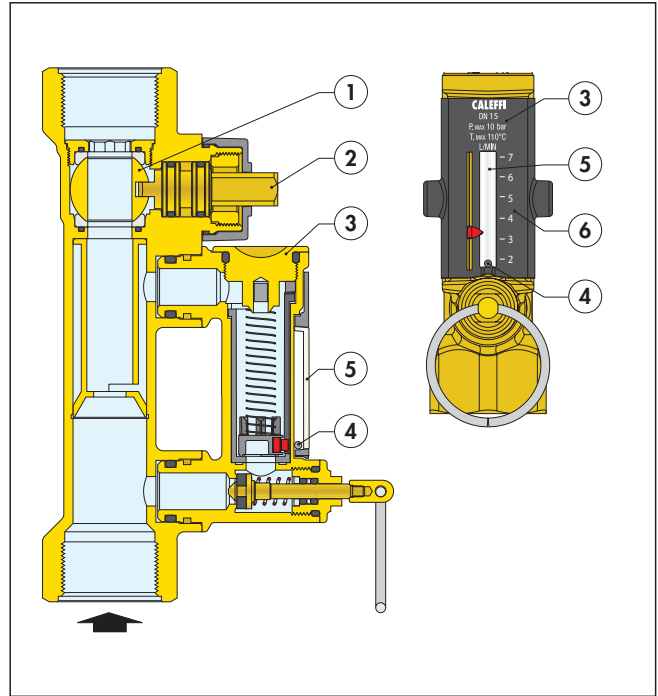

Flow meter bypass valve

The bypass valve (1) opens and closes the circuit between the flow meter and the valve. The bypass valve is easily opened by pulling the operating ring (2), and is automatically closed by the internal return spring (3) when finished reading the flow rate. The spring and the EPDM seal (4) provide a reliable seal to isolate the flow meter during normal operation, protecting potential debris from interfering with spring/magnetic disc mechanism. The operating ring (2) material has low thermal conductivity to avoid burns if the flow meter is opened while hot fluid is passing through the valve.

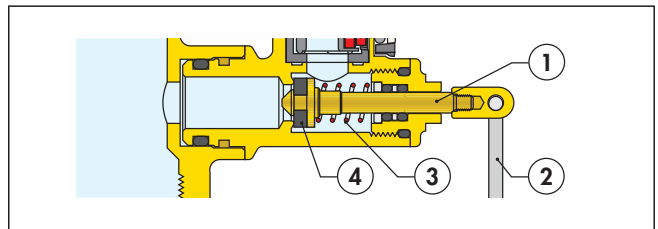

Ball/magnet indicator

The metal ball (4) that indicates the flow rate is not in direct contact with the heating/cooling transfer fluid passing through the flow meter. This is an effective and innovative measuring system in which the ball slides up and down inside a transparent channel (5) that is isolated from the fluid flowing through the body of the flow meter. The ball is moved by a magnet (6) connected to a float (7). In this way the flow rate indication system remains perfectly clean and provides reliable readings over time.

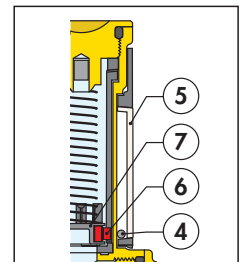

DYNAMIC BALANCING VALVES FOR PLUMBING AND HYDRONICS



127 FlowCal+™

Compact automatic recirculation balancing valves
 Patented anti-scale, low noise polymer FlowCal™ cartridge.
 Inlet flow check valve.
 Max. working pressure: 230 psi.
 Temperature range: 32–212°F.
 Max. percentage of glycol: 50%
 Flow rate range 0.35 to 10 GPM.
 Flow accuracy: ±10%.
 2" gauge diameter temperature.
 Gauge scale: 30– 210°F
 Gauge accuracy: ± 6°F



127 FlowCal™

Compact automatic recirculation balancing valves.
 Patented anti-scale, low noise polymer
 Max. working pressure: 230 psi
 Temperature range: 32–212°F.
 Max. percentage of glycol: 50%
 Flow rate range 0.35 to 10 GPM.
 Flow accuracy: ±10%.

Without temperature gauge:

Code	Description	Lbs	USD
127141AFC ***	1/2" NPT male union	1.0	96.10
127144AFC ***	1/2" PEX crimp union	1.0	95.00
127142AFC ***	1/2" PEX expansion union	1.0	95.00
127149AFC ***	1/2" sweat union	0.8	95.00
127151AFC ***	3/4" NPT male union	1.0	102.00
127156AFC ***	3/4" press union	1.0	118.00
127154AFC ***	3/4" PEX crimp union	1.0	103.00
127152AFC ***	3/4" PEX expansion union	1.0	103.00
127159AFC ***	3/4" sweat union	0.8	103.00
127161AFC ***	1" NPT male union	1.2	129.00
127166AFC ***	1" press union	1.3	135.00
127164AFC ***	1" PEX crimp union	1.3	128.00
127162AFC ***	1" PEX expansion union	1.3	128.00
127169AFC ***	1" sweat union	1.0	128.00

With temperature gauge:

Code	Description	Lbs	USD
127140AFC ***	1/2" NPT male union	1.2	129.00
127145AFC ***	1/2" PEX crimp union	1.2	125.00
127143AFC ***	1/2" PEX expansion union	1.2	125.00
127148AFC ***	1/2" sweat union	1.0	125.00
127150AFC ***	3/4" NPT male union	1.2	154.00
127157AFC ***	3/4" press union	1.2	150.00
127155AFC ***	3/4" PEX crimp union	1.2	136.00
127153AFC ***	3/4" PEX expansion union	1.2	136.00
127158AFC ***	3/4" sweat union	1.0	136.00
127160AFC ***	1" NPT male union	1.4	160.00
127167AFC ***	1" press union	1.5	166.00
127165AFC ***	1" PEX crimp union	1.5	158.00
127163AFC ***	1" PEX expansion union	1.5	158.00
127168AFC ***	1" sweat union	1.2	158.00

Select desired flow rate from next page to complete full part number. No restrictions.

Code	Description	Lbs	USD
127341AF ***	1/2" NPT male union	1.0	91.60
127346AF ***	1/2" press union	1.0	101.00
127344AF ***	1/2" PEX crimp union	1.0	86.60
127342AF ***	1/2" PEX expansion union	1.0	86.60
127349AF ***	1/2" sweat union	0.8	86.60
127351AF ***	3/4" NPT male union	1.0	95.60
127356AF ***	3/4" press union	1.0	111.00
127354AF ***	3/4" PEX crimp union	1.0	91.10
127352AF ***	3/4" PEX expansion union	1.0	91.10
127359AF ***	3/4" sweat union	0.8	91.10
127361AF ***	1" NPT male union	1.2	109.00
127366AF ***	1" press union	1.3	137.00
127364AF ***	1" PEX crimp union	1.3	105.00
127362AF ***	1" PEX expansion union	1.3	105.00
127369AF ***	1" sweat union	1.0	105.00

Select desired flow rate from next page to complete full part number. No restrictions.

Application diagram

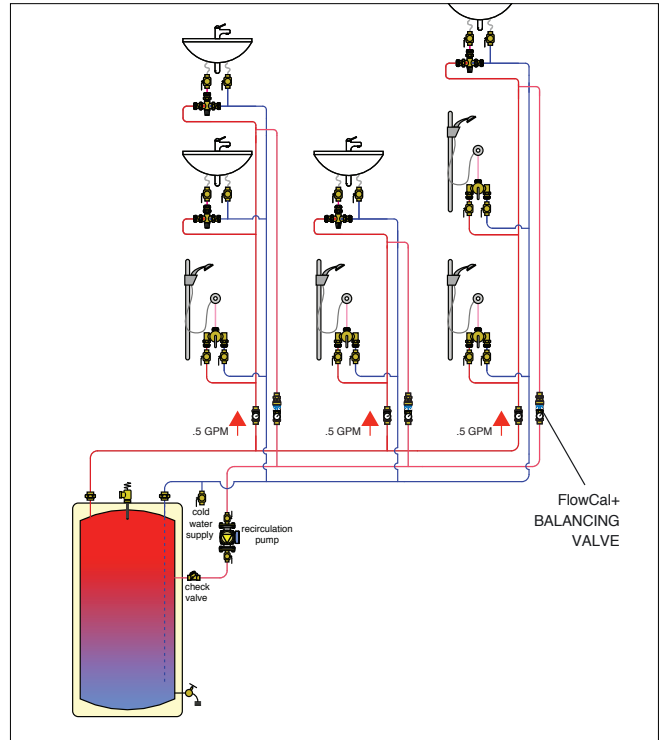

Complies with NSF/ANSI 372-2011, low lead laws, for use in accordance with the U.S. and Canadian plumbing codes. US Patent 7,246,635 B2.

DYNAMIC BALANCING VALVES FOR PLUMBING AND HYDRONICS

Construction details

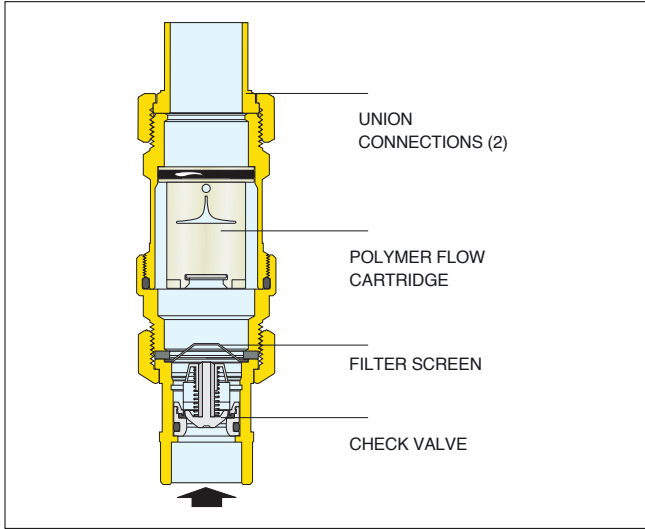

Below the differential pressure control range (< 2 psid)*

In this case, the spring-loaded regulating piston remains in equilibrium without compressing the spring and gives the fluid the maximum free flow area. When below the differential pressure control range the piston acts as a fixed orifice and thus the flow rate through the FlowCal depends only on the differential pressure.

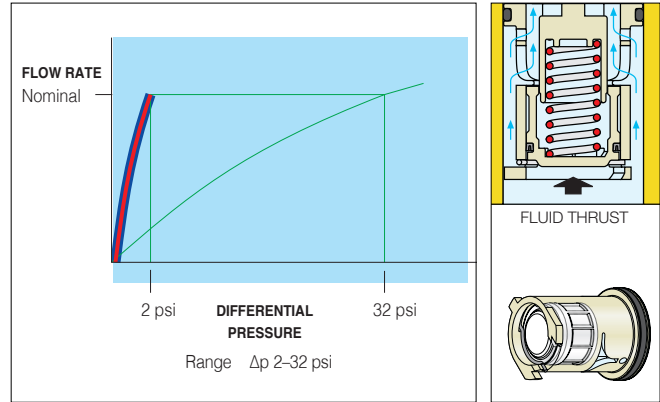

Flow rate selection

GPM	Last 3 digits ...	Differential Pressure Control Ranges (psid)
.35	G35	2-14
.5	G50	
.75	G75	
1	1G0	2-32
1.3	1G3	
1.5	1G5	
1.7	1G7	
2	2G0	
2.2	2G2	
2.5	2G5	
2.6	2G6	
3	3G0	
3.5	3G5	
4	4G0	4-34
4.5	4G5	
5	5G0	
6	6G0	5-35
7	7G0	
8	8G0	
9	9G0	
10	10G	

Within the differential pressure control range (2 - 32 psid)*

If the differential pressure is within the control range, the spring-loaded piston is positioned to give the fluid a free flow area permitting regular flow at the nominal rate for which the FlowCal is set up.

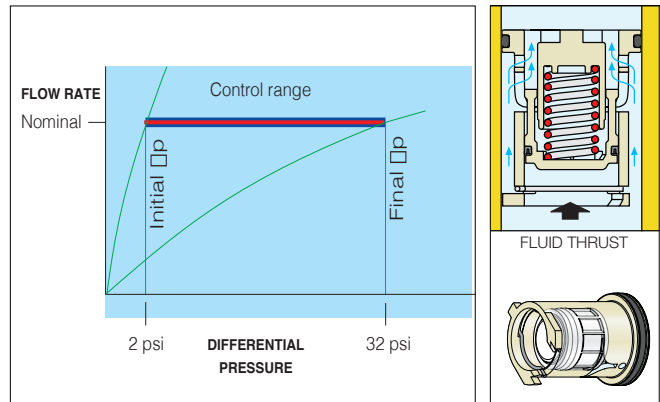

Above the differential pressure control range (> 32 psid)*

In this case, the spring-loaded piston fully compresses a spring and leaves only the fixed orifice for the fluid to pass through. The flow rate through the FlowCal depends only on the differential pressure.

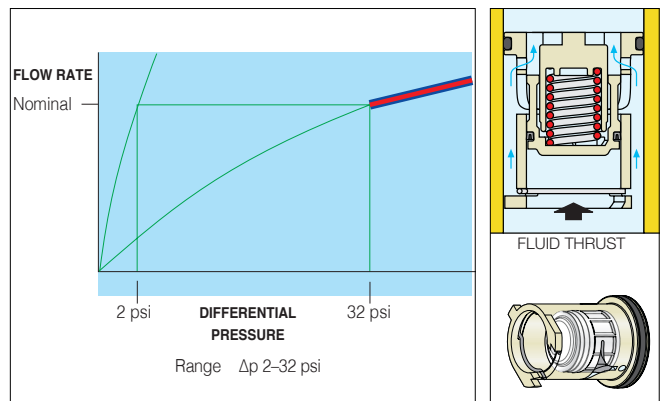

NEW



Isolation ball valve.
Low lead MxF union fits 1" valves between body and tailpiece.

Code	Description	Lbs	USD
290030	Isolation ball valve 1" M x 1" F union	1	35.00

THERMAL BALANCING VALVES FOR PLUMBING



**1161
ThermoSetter™**

Adjustable thermal balancing valve for domestic hot water recirculation circuits. Body has section for thermal disinfection cartridge retrofit. Drywell for temperature gauge or probe. Max. working pressure: 230 psi. Adjustment temperature range: 95°F — 140°F. ½" and ¾" models: Cv max: 2.1; Cv min: 0.23; Cv design: 0.52. 1" and 1¼" models: Cv max: 4.4; Cv min: 1.0; Cv design: 1.9.



**1163
ThermoSetter™**

Adjustable thermal balancing valve for domestic hot water recirculation circuits. With by-pass valve for thermal disinfection. Purchase 656 actuator separately. Drywell includes temperature gauge. DZR low-lead brass body. Optional outlet check valve. Max. working pressure: 230 psi. Adjustment temperature range: 95°F — 140°F. ½" and ¾" models: Cv max: 2.1; Cv min: 0.23. 1" and 1¼" models: Cv max: 4.4; Cv min: 1.0. Cv disinfection: 2.3; Cv design: 1.9.

Code	Description	Lbs	USD
116140A	½" FNPT	1.6	180.00
116140AC	½" FNPT, check valve	1.8	215.00
116141A	½" FNPT, gauge	1.7	192.00
116141AC	½" FNPT, gauge, check valve	1.9	227.00
116150A	¾" FNPT	1.5	193.00
116150AC	¾" FNPT, check valve	1.7	235.00
116151A	¾" FNPT, gauge	1.6	205.00
116151AC	¾" FNPT, gauge, check valve	1.8	247.00
116160A	1" FNPT	NEW 2.1	274.00
116160AC	1" FNPT, check	NEW 2.3	381.00
116161A	1" FNPT, gauge	NEW 2.2	287.00
116161AC	1" FNPT, gauge, check	NEW 2.4	394.00
116170A	1¼" FNPT	NEW 2	295.00
116170AC	1¼" FNPT, check	NEW 2.2	412.00
116171A	1¼" FNPT, gauge	NEW 2.1	307.00
116171AC	1¼" FNPT, gauge, check	NEW 2.3	424.00

Code	Description	Lbs	USD
116340A	½" FNPT	1.8	246.00
116340AC	½" FNPT, check valve	2.0	283.00
116350A	¾" FNPT	1.7	259.00
116350AC	¾" FNPT, check valve	1.9	301.00
116360A	1" FNPT, gauge	NEW 2.3	341.00
116360AC	1" FNPT, gauge, check valve	NEW 2.5	448.00
116370A	1¼" FNPT, gauge	NEW 2.2	361.00
116370AC	1¼" FNPT, gauge, check valve	NEW 2.4	478.00

Operating principle

The ThermoSetter adjustable thermal balancing valve, installed at the end of each branch of the domestic hot water recirculation system, automatically maintains the set temperature. It controls the water flow rate according to the inlet temperature with the internal adjustable thermostatic cartridge. The thermostatic cartridge modulates the valve opening in response to changing water temperature, and when reaching the temperature setting, closes the valve to minimum flow position. A recirculation pump distributes flow to all the branches resulting in effective automatic thermal balancing. The automatic response allows each hot water branch to deliver hot water to each fixture. The ThermoSetter works perfectly with variable speed recirculation pumps for optimal energy usage.

Construction details 116150AC

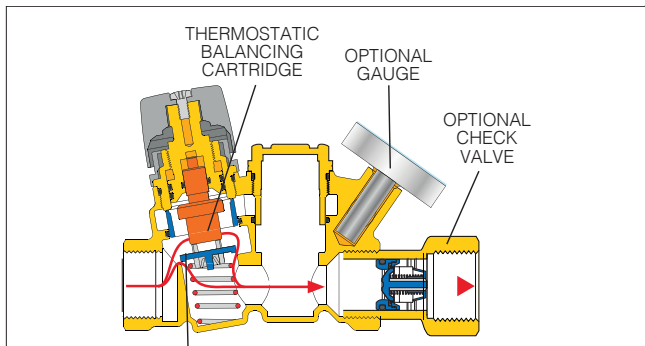

Complies with NSF/ANSI 372-2011 low lead laws for use in accordance with the U.S. and Canadian plumbing codes, and with NSF/ANSI/CAN 61 (180F).

**1162, 1166
ThermoSetter™**



Adjustable thermal balancing valve for domestic hot water recirculation circuits. With thermal by-pass cartridge for thermal disinfection. Drywell includes temperature gauge. Max. working pressure: 230 psi. Adjustment temperature range: 95°F — 140°F. ½" and ¾" models: Cv max: 2.1; Cv min: 0.23. Cv disinfection: 1.2; Cv design: 0.52. 1" and 1¼" models: Cv max: 4.4; Cv min: 1.0. Cv disinfection: 2.3; Cv design: 1.9.

Code	Description	Lbs	USD
116240A	½" FNPT, 160°F bypass	1.8	234.00
116240AC	½" FNPT, check valve, 160°F bypass	2	269.00
116250A	¾" FNPT, 160°F bypass	1.7	247.00
116250AC	¾" FNPT, check valve, 160°F bypass	1.9	289.00
116260A	1" FNPT, 160°F bypass	NEW 1.8	329.00
116260AC	1" FNPT check, 160°F bypass	NEW 2	434.00
116270A	1-1/4" FNPT, 160°F bypass	NEW 1.7	350.00
116270AC	1¼" FNPT, check, 160°F bypass	NEW 1.9	467.00
116640A	½" FNPT, 140°F bypass	NEW 1.8	234.00
116640AC	½" FNPT, check valve, 140°F bypass	NEW 2	269.00
116650A	¾" FNPT, 140°F bypass	NEW 1.7	247.00
116650AC	¾" FNPT, check valve, 140°F bypass	NEW 1.9	289.00
116660A	1" FNPT, 140°F bypass	NEW 2.3	329.00
116660AC	1" FNPT, check, 140°F bypass	NEW 2.5	434.00
116670A	1¼" FNPT, 140°F bypass	NEW 2.2	350.00
116670AC	1¼" FNPT, check, 140°F bypass	NEW 2.4	467.00

THERMAL BALANCING VALVES FOR PLUMBING



1164 ThermoSetter™

Compact adjustable thermal balancing valve for domestic hot water recirculation circuits. Drywell for temperature gauge or probe. DZR low-lead brass body. Optional outlet check valve. Max. working pressure: 230 psi. Adjustment temperature range: 105°F — 150°F. Cv max: 2.1; Cv min: 0.35. Cv design: 0.69. Certified to Low Lead Laws and listed by ICC-ES for use in accordance with the U.S. and Canadian plumbing codes. NSF/ANSI/CAN 61 to 180°F approval.

Code	Description	Lbs	USD
116440A	½" FNPT	1.6	163.00
116440AC	½" FNPT, check valve	1.8	198.00
116441A	½" FNPT, gauge	1.5	173.00
116441AC	½" FNPT, gauge, check valve	1.7	210.00
116450A	¾" FNPT	1.6	175.00
116450AC	¾" FNPT, check valve	1.8	216.00
116451A	¾" FNPT, gauge	1.5	186.00
116451AC	¾" FNPT, gauge, check valve	1.7	228.00

Construction details

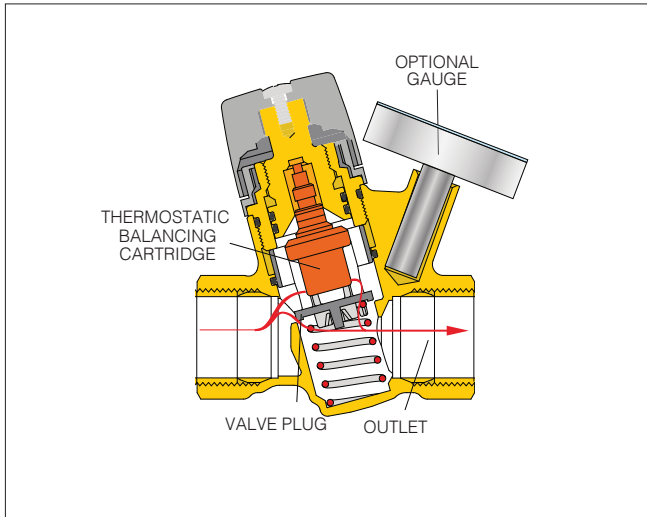

Check valve fits 116 ThermoSetter™. DZR low-lead brass. Max. working pressure: 150 psi. Max. working temperature: 250°F.

Code	Description	Lbs	USD
NA10469	½" FNPT x MNPT inline check valve	0.1	36.30
NA10467	¾" FNPT x MNPT inline check valve	0.1	42.30
NA51361*	1" MNPT in, 1" FNPT out	NEW 1.1	105.00
NA51371*	1¼" MNPT in, 1¼" FNPT out	NEW 1.3	115.00

*Serviceable stainless steel check

Operating principle

The ThermoSetter™ compact adjustable thermal balancing valve is used for automatic balancing of recirculation loops in domestic hot water systems, to speed hot water delivery, reduce water waste and save energy. It does not have a bypass cartridge option so is not intended for thermal disinfection applications. The internal thermostatic balancing cartridge automatically modulates flow to ensure a constant temperature in the recirculation piping system. The 116 Series has an adjustment knob with temperature scale indication. An integral dry-well holds a slide-in temperature gauge for local indication, or a sensor for remote temperature sensing. The optional check valve protects against circuit thermo-syphoning.



Actuator disinfection cartridge for use with 656 actuator.

Code	Description	Lbs	USD
116000	Replacement actuator bypass cartridge	0.1	54.50



Thermal disinfection bypass cartridges.

Code	Description	Lbs	USD
F0001286	140°F bypass cartridge	0.1	42.30
F0000580	160°F bypass cartridge	0.1	42.30



Replacement main balancing cartridges

Code	Description	Lbs	USD
F0001516	½", ¾" balancing cartridge	0.1	42.30



Temperature gauge fits 116 series. Working temperature range: 30°F — 180°F.

Code	Description	Lbs	USD
116010	1½" dial temp. gauge	0.1	12.00



Insulation shell fits 116 series thermal balancing valve.

Code	Description	Lbs	USD
CBN116140*	Insulation shell for 1161, 1162, 1163	0.1	29.00
CBN116440*	Insulation shell for 1164	0.1	28.60
CBN116160**	Insulation shell for 1161, 1162, 1163	0.1	31.00

*Fits ½" and ¾"
**Fits 1" and 1¼"

STATIC BALANCING VALVES, FIXED ORIFICE, FOR PLUMBING AND HYDRONICS

130 Flo-Set™ Fixed Orifice



Fixed orifice.
 Multi-turn adjustment range.
 Memory stop feature.
 Max. working pressure: 232 psi.
 Working temperature range: -4 to 250°F.
 Number of adjustment turns: 6.
 DZR Low-lead brass body.
 Stainless steel valve plug.
 Teflon® stem guide bearing.
 Meets requirements of NSF/ANSI 372-2011.
 Complies with low lead laws and listed by ICC-ES for use in accordance with the U.S. and Canadian plumbing codes.



Insulation shell fits 130 series balancing valves.

Code	Description	Max Cv	Lbs	USD
130400A	½" NPT female	3.7	1.0	119.00
130500A	¾" NPT female	5.1	1.2	130.00
130600A	1" NPT female	8.8	1.5	155.00
130700A	1¼" NPT female	14.0	2.0	194.00
130800A	1½" NPT female	19.7	2.3	242.00
130900A	2" NPT female	30.5	2.5	322.00

Code	Description	Lbs	USD
CBN130400	fits ½" NPT	0.1	26.20
CBN130500	fits ¾" NPT	0.1	28.40
CBN130600	fits 1" NPT	0.1	34.10
CBN130700	fits 1¼" NPT	0.1	42.60
CBN130800	fits 1½" NPT	0.1	53.10
CBN130900	fits 2" NPT	0.1	70.80

Construction details

The 130 series balancing valve is a hydraulic device that controls the flow rate of a fluid. Turning the knob moves a plug within the fluid stream which varies the flow rate. The flow rate is determined according to the pressure drop value measured by a differential pressure meter connected to the pressure test ports.

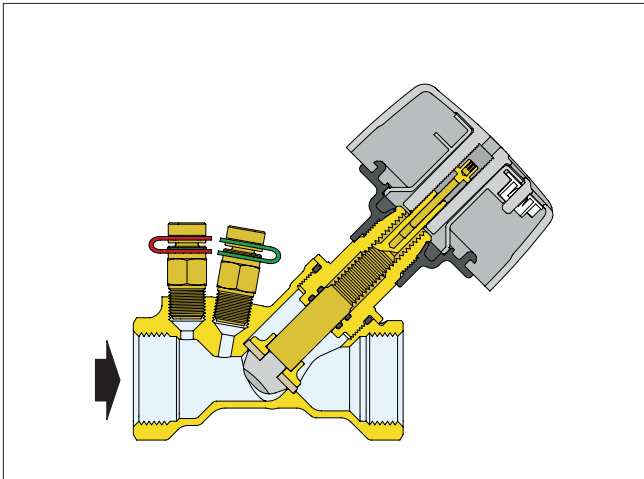

Venturi flow rate measurement device

As shown in the figure below, the 130 series balancing valve contains two closely spaced pressure test ports located upstream of the valve plug and at different cross sectional areas. As fluid flows through the valve, the velocity at the port closest to the plug is greater than the velocity at the port furthest. The result, referred to as the Venturi effect, is an induced pressure differential across the ports.

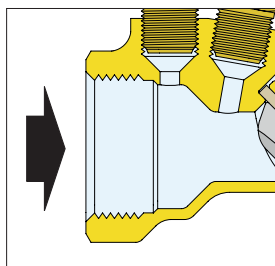

Adjustment knob The shape of the knob is designed to ensure maximum comfort for the operator and an accurate adjustment. 6 full turns of rotation with 10 decimal graduations per rotation allows for precise valve adjustment. Shades of the scale indicator are large and clear allowing for easy, accurate reading. The knob is made of a reinforced high strength corrosion-resistant polymer.

Adjustment reference scale Each 360° rotation of the knob moves the turn indicator by one position, ranging from 0 (valve closed) to 6 (valve fully open). A geared drive allows for decimal graduations of the scale situated around the knob itself letting the flow rate to be finely tuned.

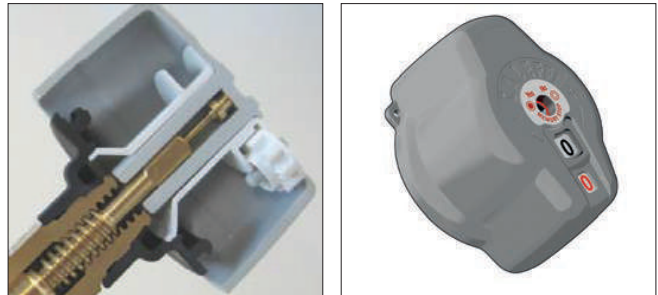

Memory stop The 130 series balancing valve features a memory stop that allows the valve to be reopened to the initial position if it has been closed for any reason such as isolating components in the balanced circuit. Locking the position to be memorized requires the use of a 2.5 mm hex key.

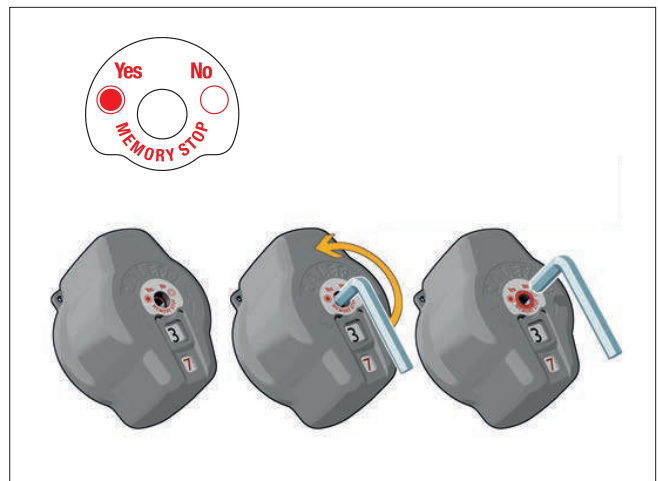

STATIC BALANCING VALVES, VARIABLE ORIFICE, FOR PLUMBING AND HYDRONICS



142 Flo-Set™ Variable Orifice

Memory stop feature.
 Characterized plug for smooth adjustment.
 Maximum working pressure: 232 psi.
 Working temperature range: 14–250°F.
 DZR low-lead brass body.
 Meets requirements of NSF/ANSI 372-2011.
 Complies with low lead laws and listed by ICC-ES for use in accordance with the U.S. and Canadian plumbing codes.

Code	Description	Max Cv	Lbs	USD
142241A	½" NPT female	3.4	1.0	93.30
142251A	¾" NPT female	5.0	1.2	99.50
142261A	1" NPT female	7.5	1.5	135.00
142271A	1¼" NPT female	12.9	2.3	193.00
142281A	1½" NPT female	16.8	3.0	216.00
142291A	2" NPT female	22.0	3.5	276.00

Operating Principal

The 142 series balancing valve is a hydraulic device that controls the flow rate of a fluid. Turning the knob moves a plug within the fluid stream which varies the flow rate. The flow rate is determined according to the pressure drop value measured by a differential pressure meter connected to the pressure test ports and the adjustment knob position.

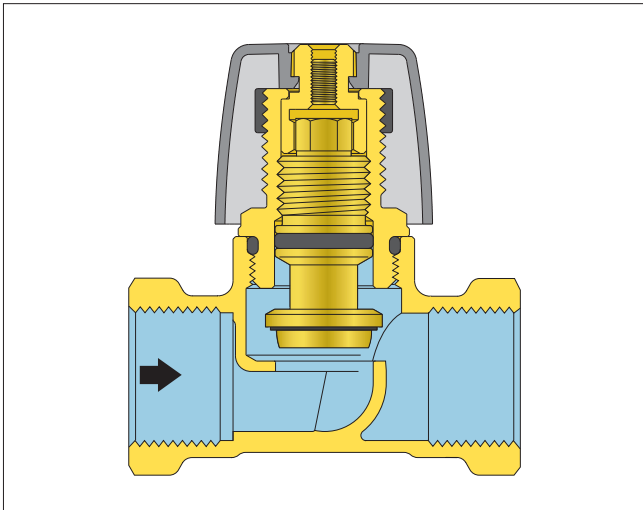

Adjustment knob The knob is made of a reinforced high strength corrosion-resistant polymer. The shape of the knob is designed to ensure maximum comfort for the operator and an accurate adjustment.

Adjustment reference scale Each 360° rotation of the knob moves the turn indicator by one position, ranging from 0 (valve closed) to 4 (valve fully open).



Insulation shell fits 142 series balancing valves.

Code	Description	Lbs	USD
CBN142241A	fits ½" NPT	0.1	24.00
CBN142251A	fits ¾" NPT	0.1	25.50
CBN142261A	fits 1" NPT	0.1	34.80
CBN142271A	fits 1¼" NPT	0.1	49.60
CBN142281A	fits 1½" NPT	0.1	55.80

Memory stop The 130 series balancing valve features a memory stop that allows the valve to be reopened to the initial position if it has been closed for any reason such as isolating components in the balanced circuit. Locking the position to be memorized requires the use of a 2.5 mm hex key.

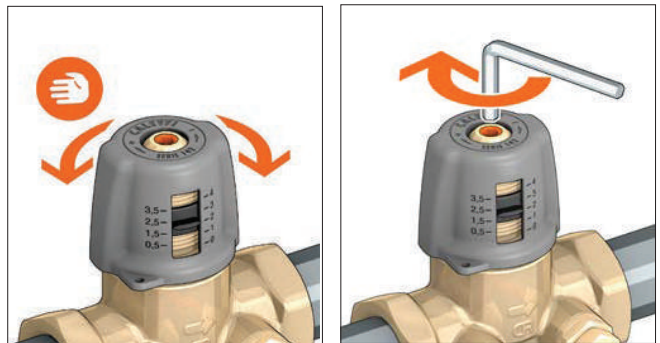

Fast-coupling pressure test ports The 130 series balancing valve has as standard probe type, fastcoupling pressure test ports. The probe from the differential pressure meter is inserted into the port packing, until the end of the probe enters the system. When the measuring probe is pulled out, the test port automatically closes, preventing fluid leakage. Care should be taken to pull the probe out slowly so as to allow adequate time for the packing to re-seal – otherwise fluid can quickly escape creating a hazardous situation. Consult differential pressure meter manufacturer instructions for proper use of instrument and pressure port couplings.

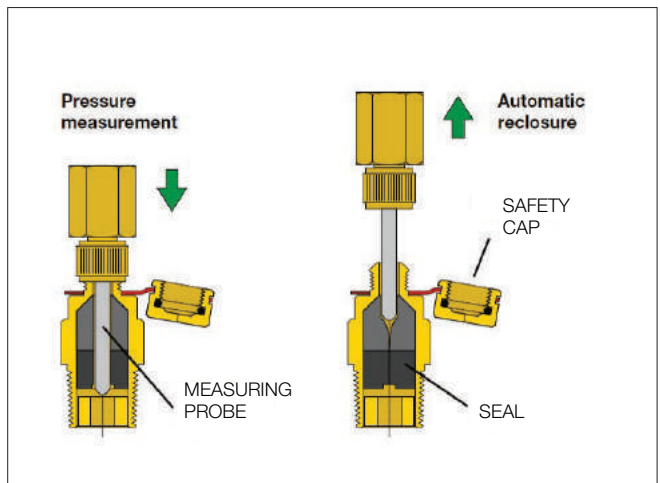

DYNAMIC BALANCING VALVES FOR HYDRONICS



**121
FlowCal™**

Automatic flow balancing valve with integral ball valve.
 Brass body.
 Patented anti-scale, low noise polymer FlowCal™ cartridge.
 Maximum working pressure: 400 psi (400 WOG).
 Working temperature range: 32–212°F (0 –100°C).
 Max. percentage of glycol: 50%.
 Differential pressure control ranges: 2–14, 2–32, 4–34, 5–35 psid.
 Flow rate: fixed flow rate settings ranging from 0.35–21 GPM.
 Flow accuracy: ±10%.
 US Patent 7,246,635 B2.

Available with optional factory-installed pressure and temperature test ports (1213xxx series).

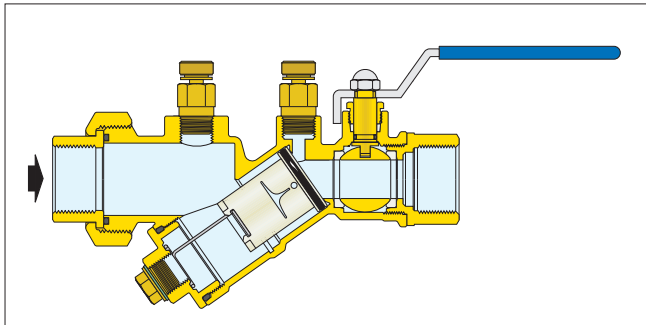

Code	Description	Lbs	USD
121141A ●●●	1/2" NPT female	2.7	119.00
121149A ●●●	1/2" sweat	2.7	114.00
121151A ●●●	3/4" NPT female	2.7	120.00
121159A ●●●	3/4" sweat	2.7	115.00
121161A ●●●	1" NPT female	5.0	246.00
121169A ●●●	1" sweat	5.0	235.00
121171A ●●●	1 1/4" NPT female	5.0	276.00
121179A ●●●	1 1/4" sweat	5.0	263.00
121341A ●●●	1/2" NPT female with PT test ports	3.2	129.00
121349A ●●●	1/2" sweat with PT test ports	3.2	122.00
121351A ●●●	3/4" NPT female with PT test ports	3.2	131.00
121359A ●●●	3/4" sweat with PT test ports	3.2	123.00
121361A ●●●	1" NPT female with PT test ports	5.5	255.00
121369A ●●●	1" sweat with PT test ports	5.5	244.00
121371A ●●●	1 1/4" NPT female with PT test ports	5.5	285.00
121379A ●●●	1 1/4" sweat with PT test ports	5.5	271.00

Select desired flow rate to complete full part number.

Size	GPM	Last 3 digits ...	Differential Pressure Control Ranges (psid)
1/2", 3/4"	0.35	G35	2 – 14
1/2", 3/4"	0.5	G50	
1/2", 3/4"	0.75	G75	
1/2", 3/4"	1	1G0	2 – 32
1/2", 3/4"	1.3	1G3	
1/2", 3/4"	1.5	1G5	
1/2", 3/4"	1.7	1G7	
1/2", 3/4"	2	2G0	
1/2", 3/4"	2.2	2G2	
1/2", 3/4"	2.5	2G5	4 – 34
1/2", 3/4", 1"	2.6	2G6	
1/2", 3/4", 1"	3	3G0	
1/2", 3/4", 1"	3.5	3G5	
1/2", 3/4", 1", 1 1/4"	4	4G0	
1/2", 3/4", 1", 1 1/4"	4.5	4G5	
1/2", 3/4", 1", 1 1/4"	5	5G0	
1/2", 3/4", 1", 1 1/4"	6	6G0	
1/2", 3/4", 1", 1 1/4"	7	7G0	
1/2", 3/4", 1", 1 1/4"	8	8G0	

Size	GPM	Last 3 digits ...	Differential Pressure Control Ranges (psid)
1/2", 3/4", 1", 1 1/4"	9	9G0	5 – 35
1/2", 3/4", 1", 1 1/4"	10	10G	
1", 1 1/4"	11	11G	3 – 32
1", 1 1/4"	12	12G	
1", 1 1/4"	13	13G	4 – 35
1", 1 1/4"	14	14G	
1", 1 1/4"	15	15G	
1", 1 1/4"	16	16G	
1", 1 1/4"	17	17G	
1", 1 1/4"	18	18G	
1", 1 1/4"	19	19G	
1", 1 1/4"	20	20G	
1", 1 1/4"	21	21G	

Size	Flow Rates
1/2"	.35 –10 GPM
3/4"	.35 –10 GPM
1"	2.5–21 GPM
1 1/4"	4–21 GPM

Replacement flow cartridge kits are available. Consult factory.

Y-STRAINER WITH BALL VALVE FOR HYDRONICS

**120
Y-strainer**

Y-strainer with integral ball valve. Brass body. Stainless steel strainer cartridge. Maximum working pressure: 400 psi (400 WOG). Working temperature range: 32–212°F. Max. percentage glycol: 50%. Strainer (20 mesh). Connections: —body: F NPT union x F NPT, sweat union x sweat. Pressure and temperature ports: ¼" NPT. Drain port connection: ¼" for ½" & ¾" or ½" for 1" & 1¼".



Code	Description	Cv	Lbs	USD
120141A 000	½" NPT female	8.0	3.0	108.00
120149A 000	½" sweat	8.0	3.0	103.00
120151A 000	¾" NPT female	8.4	3.0	109.00
120159A 000	¾" sweat	8.4	3.0	104.00
120161A 000	1" NPT female	19	6.0	216.00
120169A 000	1" sweat	19	6.0	206.00
120171A 000	1¼" NPT female	20	6.0	246.00
120179A 000	1¼" sweat	20	6.0	235.00
120341A 000	½" NPT female with PT	8.0	3.5	117.00
120349A 000	½" sweat with PT	8.0	3.5	112.00
120351A 000	¾" NPT female with PT	8.4	3.5	118.00
120359A 000	¾" sweat with PT	8.4	3.5	113.00
120361A 000	1" NPT female with PT	19	6.5	226.00
120369A 000	1" sweat with PT	19	6.5	214.00
120371A 000	1¼" NPT female with PT	20	6.5	255.00
120379A 000	1¼" sweat with PT	20	6.5	244.00

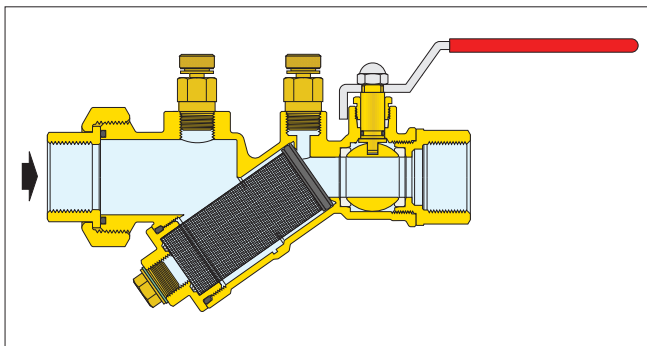

STATIC BALANCING WITH FLOW METER

NA223

Direct in-line balancing / flow meter with brass body for hydronic applications only. Max percentage of glycol: 50%. Max working pressure: 150 psi. Temperature range: 32–250°F. Measuring accuracy: ±10%. Cv: 6.0. See fitting selection table in Section 9.



Code	Description	Lbs	USD
NA223529	2 to 8 gpm with 1" union thread	0.9	100.00



Two union nuts, washers and tail pieces. Low-lead brass.

Code	Description	Lbs	USD
NA12249	½" sweat with 1" union nuts	0.2	23.90
NA12259	¾" sweat with 1" union nuts	0.2	28.60
NA12269	1" sweat with 1" union nuts	0.3	50.00

538

Drain valves for field installation in blow-down-port connection of the 120 series Y-strainer. Brass body. With ¾" garden hose connection. Max. working pressure: 150 psi. Max: working temperature: 250°F.



Code	Description	Lbs	USD
538202 FD	¼" NPT fits ½–¾" 120 series	0.3	12.20
538402 FD	½" NPT fits 1–1¼" 120 series	0.3	12.50

**100
PT test ports**

Fast-plug pressure/temperature test ports fits FlowCal™ automatic flow balancing valves and the 120 series Y-strainer. The double-sealing core insures long and trouble free service. Low Lead brass body. Nordel Core. Connections: ¼" NPT male. Cap thread: ⅜"-24 UNF. Working temperature range: 0–275°F. Max. working pressure: 435 psi. Pair (2 ports included).



Code	Description	Lbs	USD
100001A	Standard size, 1½" length (pair)	0.5	13.50

WORLD'S MOST RECOGNIZED PRESSURE REDUCING VALVES



The PresCal™ is constructed of dezincification-resistant low lead brass and low friction moving parts that stand up to hard water and scale for maximum durability. The fully-contained replaceable cartridge has an integral stainless steel mesh filter which makes cleaning or rebuilding the PresCal fast and easy. Approvals include compliance with NSF/ANSI/CAN 61 (rated for commercial hot water 180°F), NSF/ANSI 372 low lead laws, ASSE 1003, CSA B356, and codes IPC, IRC, UPC and NPC for use in accordance with the U.S. and Canadian plumbing codes. **CALEFFI GUARANTEED.**



PRVS, BACKFLOW PREVENTERS AND AIR VENTS

This diagram is for illustration purposes only

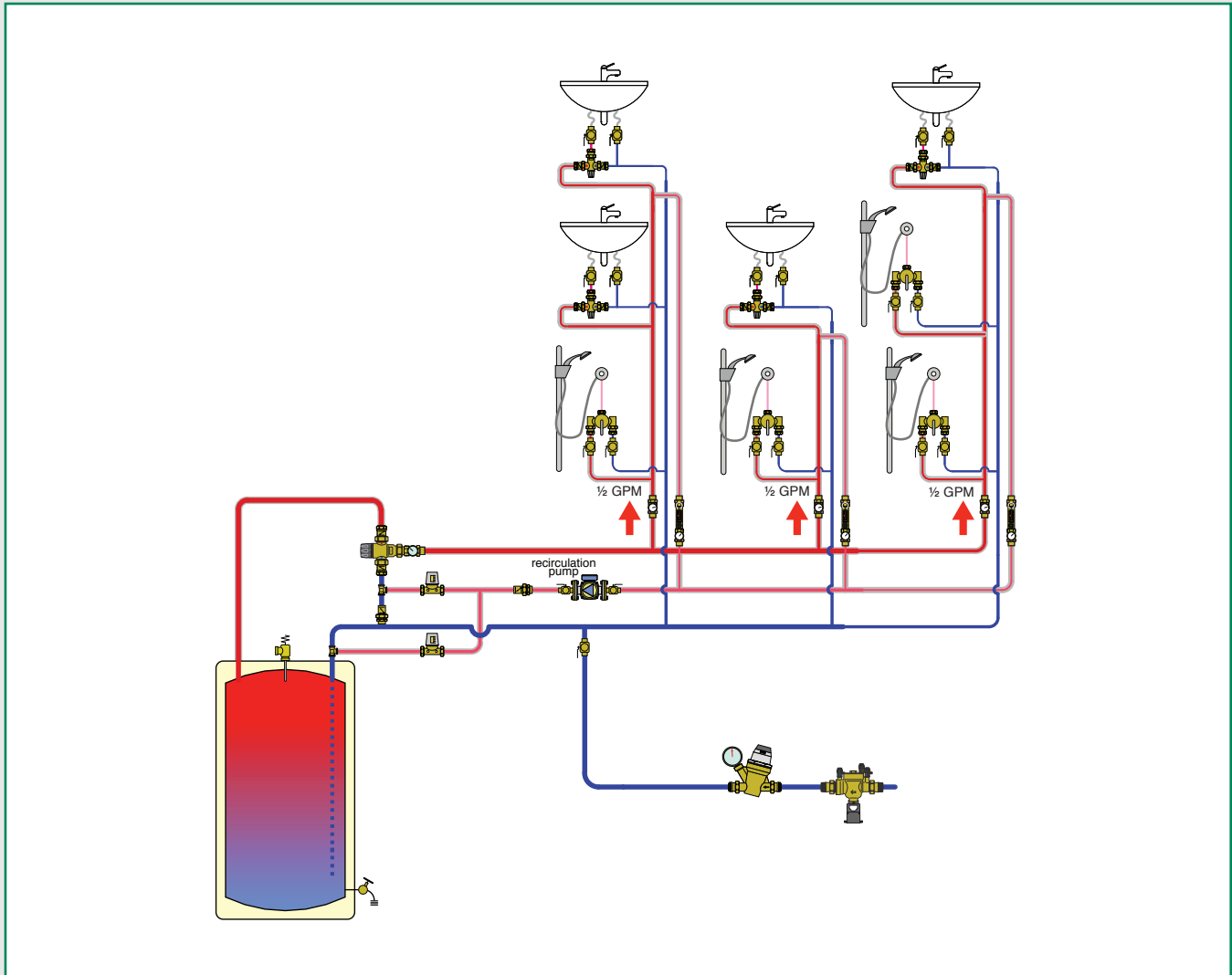

PRODUCTS INCLUDED IN SECTION

- Pressure reducing valves for plumbing
- Automatic air vent for plumbing
- Backflow preventers, dual check, for plumbing and hydronics
- Backflow preventers, RPZ type, for plumbing and hydronics

PRESSURE REDUCING VALVES FOR PLUMBING

535H PresCal™



Pressure reducing valve for residential and commercial applications.
 Max. working pressure: 300 psi.
 Max. working temperature: 180°F.
 Pressure setting range: 15 — 90 psi.
 Complies with: ASSE 1003, CSA B356, NSF/ANSI/CAN 61, NSF/ANSI 372, Low Lead Laws and listed by ICC-ES.
 Meets codes IPC, IRC & UPC for use in accordance with the U.S. and Canadian plumbing codes. Plenum rated: compliant with the requirements of standard UL 2043.

Code	Description	Max GPM	Lbs	USD
535940HA	½" sweat union	7	1.9	101.00
535941HA	½" sweat union, gauge	7	2.0	112.00
535340HA	½" NPT female union	7	2.0	110.00
535341HA	½" NPT female union, gauge	7	2.1	121.00
535950HA	¾" sweat union	12	2.2	110.00
535951HA	¾" sweat union, gauge	12	2.3	120.00
535350HA	¾" NPT female union	12	2.3	118.00
535351HA	¾" NPT female union, gauge	12	2.4	129.00
535650HA	¾" press union	12	2.3	115.00
535651HA	¾" press union, gauge	12	2.4	126.00
535750HA	¾" PEX crimp union	12	2.3	110.00
535751HA	¾" PEX crimp union, gauge	12	2.4	120.00
535550HA	¾" PEX expansion union	12	2.3	110.00
535551HA	¾" PEX expansion union, gauge	12	2.4	120.00
535960HA	1" sweat union	19	2.9	145.00
535961HA	1" sweat union, gauge	19	3.0	156.00
535360HA	1" NPT female union	19	3.0	154.00
535361HA	1" NPT female union, gauge	19	3.1	165.00
535660HA	1" press union	19	3.0	169.00
535661HA	1" press union, gauge	19	3.1	180.00
535760HA	1" PEX crimp union	19	3.0	145.00
535761HA	1" PEX crimp union, gauge	19	3.1	156.00
535560HA	1" PEX expansion union NEW	19	3.0	145.00
535561HA	1" PEX expansion union, gauge NEW	19	3.1	156.00
535970HA	1¼" sweat union	34	5.6	321.00
535971HA	1¼" sweat union, gauge	34	5.7	331.00
535370HA	1¼" NPT female union	34	5.7	329.00
535371HA	1¼" NPT female union, gauge	34	5.8	340.00
535670HA	1¼" press union	34	5.8	469.00
535671HA	1¼" press union, gauge	34	5.8	480.00
535980HA	1½" sweat union	44	7.3	450.00
535981HA	1½" sweat union, gauge	44	7.4	460.00
535380HA	1½" NPT female union	44	7.3	474.00
535381HA	1½" NPT female union, gauge	44	7.4	485.00
535680HA	1½" press union	44	7.3	673.00
535681HA	1½" press union, gauge	44	7.4	687.00
535990HA	2" sweat union	70	9.7	585.00
535991HA	2" sweat union, gauge	70	9.8	596.00
535390HA	2" NPT female union	70	9.7	582.00
535391HA	2" NPT female union, gauge	70	9.8	593.00
535690HA	2" press union	70	9.7	829.00
535691HA	2" press union, gauge	70	9.8	840.00

GPM flowrate at 6 feet per second water velocity.



535H PresCal™ Body

Replacement valve body.
 DZR low lead "Ecobrass" body.
 Gauge port plug NA10438 included with body.
 See fitting selection table in Section 8.

Code	Description	Lbs	USD
NA535840HA	½" body	1.9	77.00
NA535841HA	½" body, gauge NEW	2	87.00
NA535850HA	¾" body	2.2	81.00
NA535851HA	¾" body, gauge NEW	2.3	91.00
NA535860HA	1" body	2.9	107.00
NA535861HA	1" body, gauge NEW	3	117.00
NA535870HA	1¼" body	6.1	234.00
NA535871HA	1¼" body, gauge NEW	6.2	244.00
NA535880HA	1½" body	7.3	330.00
NA535881HA	1½" body, gauge NEW	7.4	340.00
NA535890HA	2" body	9.7	383.00
NA535891HA	2" body, gauge NEW	9.8	393.00

Construction details 535H PresCal™

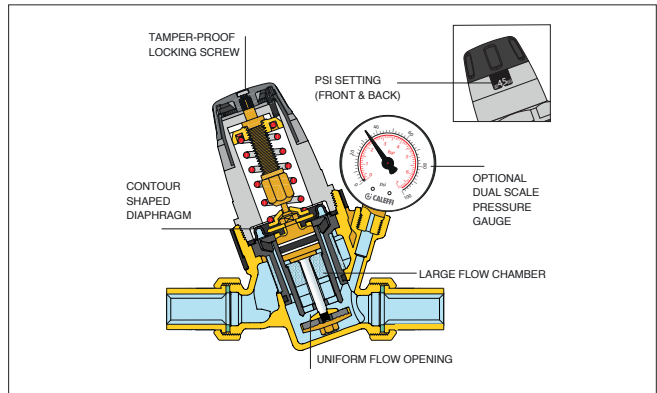

¾" 535H Falloff Performance vs. competition

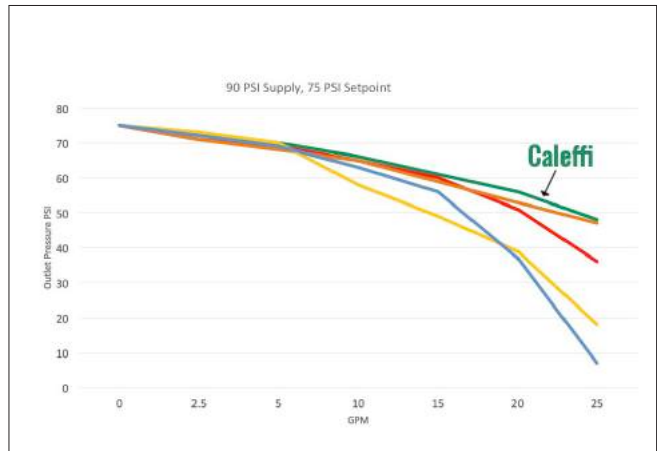

PRESSURE REDUCING VALVES FOR PLUMBING



533H PresCal™

Compact pressure reducing valve for residential and light commercial applications. DZR low lead "Ecobrass" body with inlet union connection. Low friction anti-scale moving parts. High flow seat design. Adjustment screw for pressure set point. Tamper-resistant cap included. Max. working pressure: 250 psi. Max. working temperature: 180°F. Pressure setting range: 15 — 90 psi. Factory setting: 45 psi. Complies with: ASSE 1003, CSA B356, NSF/ANSI/CAN 61, NSF/ANSI 372, Low Lead Laws and listed by ICC-ES. Meets codes IPC, IRC & UPC for use in accordance with the U.S. and Canadian plumbing codes.

Code	Description	Max GPM	Lbs	USD
533340HA*	½", NPT female union in	5.5	0.9	88.20
533341HA**	½", NPT female union in	5.5	1.1	99.70
533940HA*	½", sweat union in	5.5	0.9	80.40
533941HA**	½", sweat union in	5.5	1.1	92.00
533350HA*	¾", NPT female union in	10	1.1	94.80
533351HA**	¾", NPT female union in	10	1.3	106.00
533950HA*	¾", sweat union in	10	1.1	87.60
533951HA**	¾", sweat union in	10	1.3	99.20
533650HA*	¾", press union in	10	1.1	92.00
533651HA**	¾", press union in	10	1.3	103.00
533750HA*	¾", PEX crimp union in	10	1.1	87.60
533751HA**	¾", PEX crimp union in	10	1.3	99.20
533850HA*	¾", PEX expansion union in	10	1.1	87.60
533851HA**	¾", PEX expansion union in	10	1.3	99.20

*FNPT outlet

**FNPT outlet with gauge

Gauge port plug.



Code	Description	Lbs	USD
NA10438	⅛" NPT	0.1	2.20



PVC jumper nipple with male union thread. The length of the jumper nipple matches the 535H series valve body face-to-face dimension (B'), allowing the piping to be completed prior to the installation of valve and permitting quick change out from the jumper to the valve.

Code	Description	Lbs	USD
NA11304	Jumper nipple for 535H ½"	0.1	13.30
NA11305	Jumper nipple for 535H ¾"	0.1	14.70
NA11306	Jumper nipple for 535H 1"	0.2	15.70
NA11307	Jumper nipple for 535H 1¼"	0.3	16.90
NA11308	Jumper nipple for 535H 1½"	0.3	18.40
NA11309	Jumper nipple for 535H 2"	0.5	53.00



533H PresCal™ Body

Replacement valve body. DZR low lead "Ecobrass" body. Gauge port plug NA10438 included with body. See fitting selection table in Section 8.

Code	Description	Lbs	USD
NA533449HA	½" body	0.7	68.40
NA533459HA	¾" body	0.9	72.40



Replacement cartridge for 533H series pressure reducer.

Code	Description	Lbs	USD
533000H	Fits 533H 1/2", 3/4"	0.2	45.40

Construction details 533H PresCal™

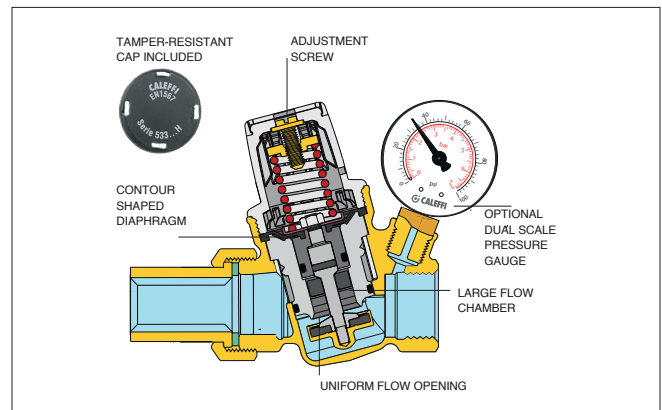

Pressure gauge fits 535H and 533H series pressure reducers. Dial size: 2". Pressure range: 0—100 psi /0-7 bar. Connection: ⅛" NPT.

Code	Description	Lbs	USD
NA10273	⅛" NPT male	0.1	12.30



Replacement cartridge for 535H series pressure reducer.

Code	Description	Lbs	USD
535006HA	Fits 535H ½", ¾", 1"	0.3	56.80
535009HA	Fits 535H 1¼", 1½", 2"	0.5	171.00

PRESSURE REDUCING VALVES FOR PLUMBING

NEW



536A PresCal™ HP

High performance piston type pressure reducing valve for high rise buildings and other applications where high pressures are present and require staged pressure control. The 536A series carries out the first stage pressure reduction in a two valve series where the pressure ratio between the inlet and outlet would be too high for a single pressure reducing valve to control. Max. working pressure: 360 psi. Max. working temperature: 180°F. Pressure setting range: 90 – 150 psi. Factory setting: 115 psi

Construction details

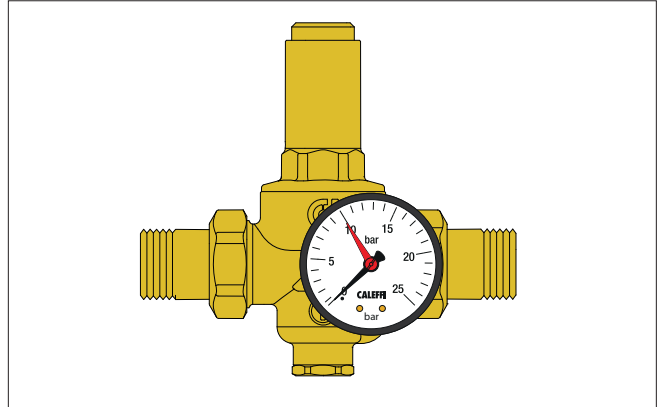

Code	Description	Max GPM	Lbs	USD
536043A 109	1/2" sweat	7	3.3	160.00
536053A 109	3/4" sweat	12	4.4	169.00
536063A 109	1" sweat	19	5	245.00
536073A 109	1-1/4" sweat	34	7.5	441.00
536083A 109	1-1/2" sweat	44	8.8	665.00
536093A 109	2" sweat	70	11.2	855.00
536043A 103	1/2" NPT female	7	3.3	168.00
536053A 103	3/4" NPT female	12	4.4	178.00
536063A 103	1" NPT female	19	5	258.00
536073A 103	1-1/4" NPT female	34	7.5	464.00
536083A 103	1-1/2" NPT female	44	8.8	700.00
536093A 103	2" NPT female	70	11.2	900.00
536053A 106	3/4" press	12	4.4	205.00
536063A 106	1" press	19	5	297.00
536073A 106	1-1/4" press	34	7.5	534.00
536083A 106	1-1/2" press	44	8.8	805.00
536093A 106	2" press	70	11.2	1,035.00

Complies with NSF/ANSI 372, Drinking Water System Components-Lead Content Reduction of Lead in Drinking Water Act, California Health and Safety Code 116875 S.3874, Reduction in Drinking Water Act, Vermont Act 193 - The Lead in Plumbing Supplies Law and Maryland's Lead Free Law HB.372, as certified by ICC-ES, file PMG-1360.

Large system with recirculation

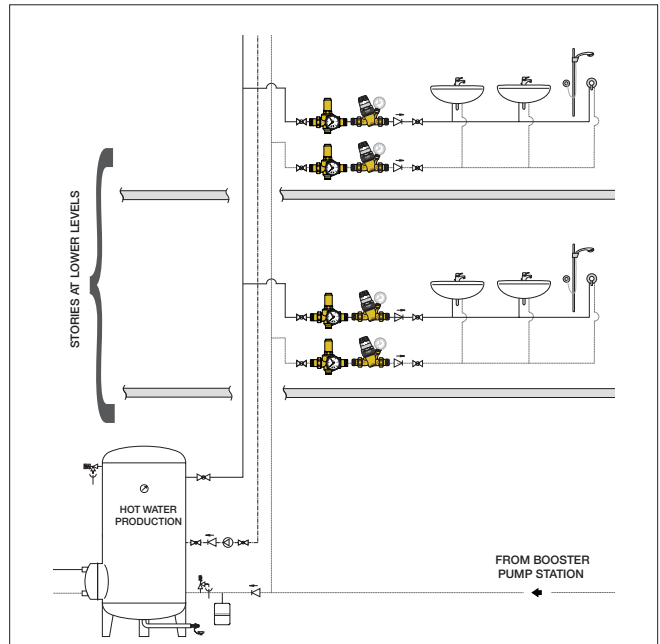

Application diagram

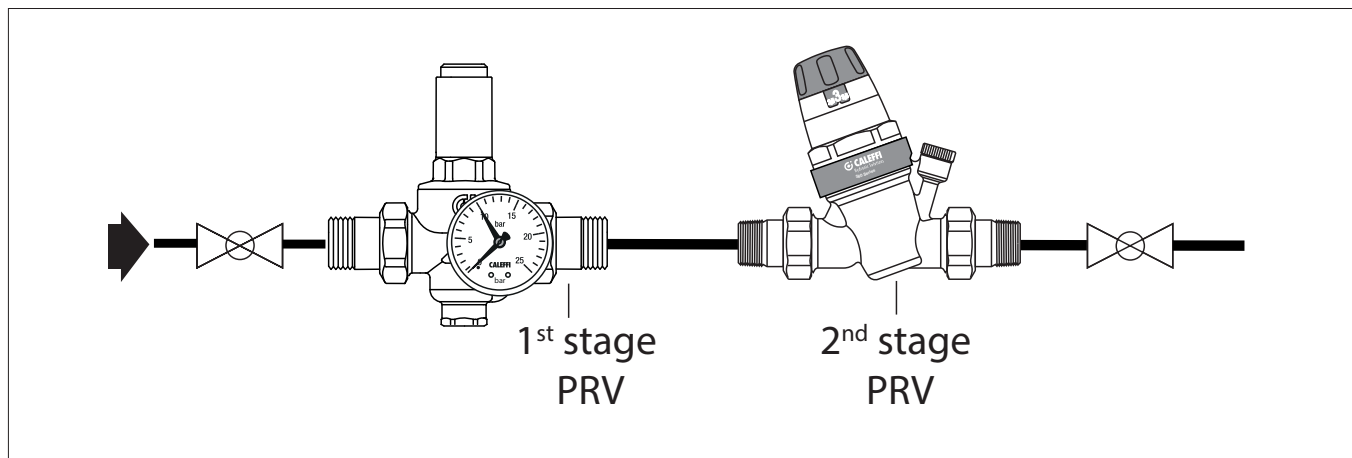

AUTOMATIC AIR VENT FOR PLUMBING



**NA5026
PLUMBVENT™**

Automatic air vent.
Compatible with plumbing systems.
Hygroscopic cap (anti-drip).
Lead free automatic air vent.
Max. working pressure: 150 psi.
Max. discharge pressure: 90 psi.
Max. discharge rate: 1.75 SCFM.
Max working temperature: 240°F.
Approval: NSF/ANSI 372 low lead.

Code	Description	Lbs	USD
NA502640A	½" MNPT	0.6	40.20

Complies with NSF/ANSI 372, Drinking Water System Components-Lead Content Reduction of Lead in Drinking Water Act, California Health and Safety Code 116875 S.3874, Reduction in Drinking Water Act, Vermont Act 193 - The Lead in Plumbing Supplies Law and Maryland's Lead Free Law HB.372, as certified by ICC-ES, file PMG-1360.

Function

Float type automatic air vent designed to vent air from water at high points in plumbing system piping. Example applications include risers, domestic hot water storage tanks and recirculation system pump inlets. The automatic air vent is installed in the vertical position in parts of the system where air has possibility accumulated. It is supplied complete with a safety hygroscopic cap that automatically closes the air discharge in case of contact with water.

Construction Diagram

Operating mechanism

The function of this device is guaranteed by an operating mechanism specially designed to vent when system pressure is high.

Antivibration and antirotation system on the float

This guarantees that in the rest position the air relief valve will not be affected by any movement of the float.

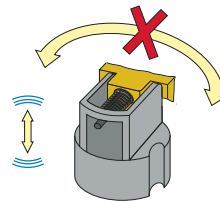
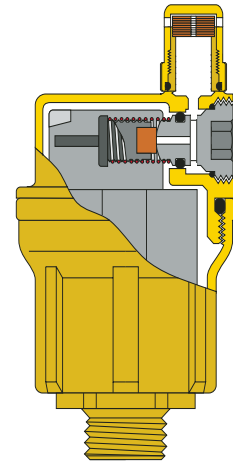

BACKFLOW PREVENTERS, DUAL CHECK, FOR PLUMBING AND HYDRONICS



Code	Description	Lbs	USD
573403A	½" NPT female unions	1.7	78.10
573406A	½" press unions	1.7	95.00
573409A	½" sweat unions	1.7	74.20
573493A	½" sweat union inlet, ½" FNPT union outlet	1.7	76.40
573503A	¾" NPT female unions	1.7	82.00
573100A*	Replacement body w/washers	1.5	57.30

*See fitting selection table in Section 8

**573
Dual Check Backflow Preventer**

Dual check continuous pressure backflow preventer with atmospheric vent.

DZR low Lead brass body.

Max. working pressure: 175 psi.

Working temperature range: 32—250°F.

Emergency backpressure temperature: 250°F.

Certified to: ASSE 1012, CSA B64.3, NSF/ANSI 372, Low Lead Laws and listed by ICC-ES. Meets codes IPC, IRC & UPC for use in accordance with the U.S. and Canadian plumbing codes.

Construction details

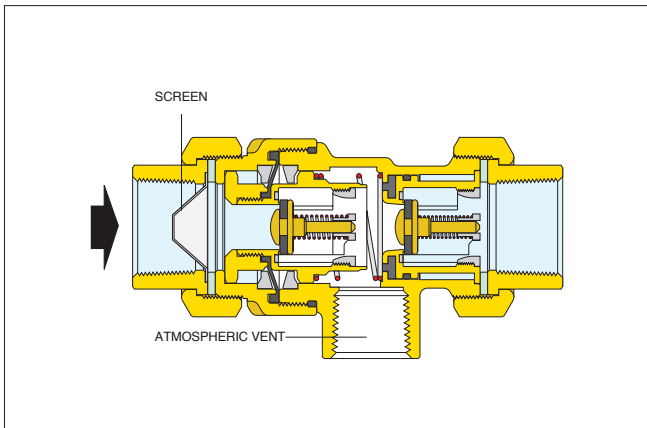

Flow capacity

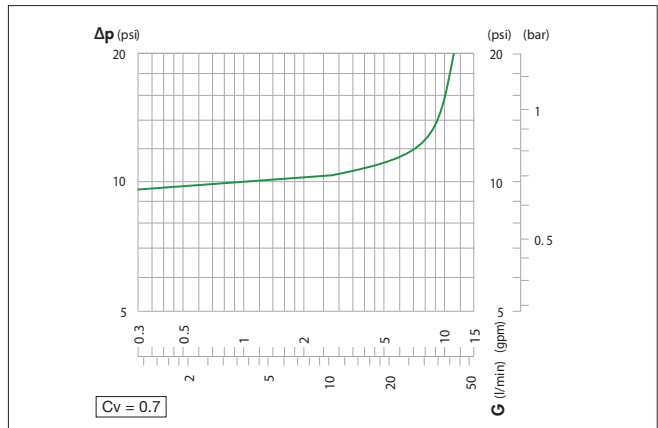

BACKFLOW PREVENTERS, RPZ TYPE, FOR PLUMBING AND HYDRONICS

574 RPZ Backflow Preventer



Testable reduced pressure zone backflow preventer.
DZR low lead brass body.
Max. working pressure: 150 psi.
Max. working temperature: 150°F.

574 RPZ Backflow Preventer



Testable reduced pressure zone backflow preventer.
DZR low lead brass body.
Max. working pressure: 150 psi.
Max. working temperature: 150°F.

Code	Description	Lbs	USD
574004A	½" FNPT	5.0	302.00
574064A	½" press	5.1	320.00
59977	Replacement upstream check valve	0.1	18.80
59978	Replacement discharge valve assembly	0.2	33.60
59979	Replacement downstream check valve	0.1	21.70
59980	Replacement discharge air gap	0.1	8.20

Code	Description	Lbs	USD
574050A	¾" FNPT	9.5	363.00
574006A	1" FNPT	11	378.00
574056A	¾" press	9.6	394.00
574066A	1" press	11	420.00
59469	Replacement upstream check valve (¾")	0.2	48.30
59470	Replacement downstream check valve (¾")	0.2	51.30
59471	Replacement discharge valve assembly (¾")	0.3	102.00
59472	Replacement valve seat (¾")	0.1	36.20
39623	Replacement discharge air gap (¾")	0.2	12.00

Function

The backflow preventer consists of two check valves and, a chamber known as "reduced pressure zone". The water entering the backflow preventer opens the upstream check valve and at the same time through the channel acts on the diaphragm which closes the discharge valve by means of the rod and then opens the downstream check valve. The pressure in the intermediate chamber under normal operating conditions is always less than the upstream pressure by at least 2 psi (140 mbar) as a result of a pre-calculated pressure loss on the first check valve. This difference in pressure Δp between the upstream and intermediate areas can be specified on a safety basis so that in the event of damage occurring, or a vacuum, the discharge valve is opened when the upstream pressure is still greater than the pressure in the intermediate area by at least 2 psi (140 mbar). In the event of damage to the diaphragm, the safety gasket under the thrust of the contrast spring prevents the return of water upstream from the discharge since there is no more Δp equilibrium between the two areas.

NOTE: For the ¾" to 1 ¼" models, to ensure correct operation the air must be released in the upper part of the diaphragm by means of the relief screw.

Function

The backflow preventer can be used in all systems where there is danger of the potable water supply system being contaminated. It prevents an accidental reduction in the pressure in the distribution system from causing backflow from contaminated water in user installations.

Construction details ½" RPZ Backflow Preventer

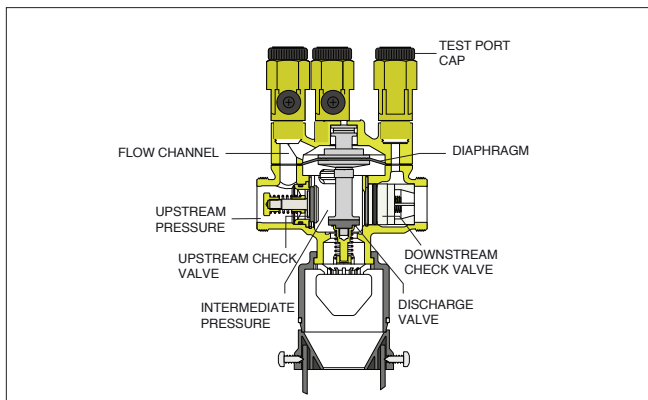

Construction details ¾, 1" RPZ Backflow Preventer

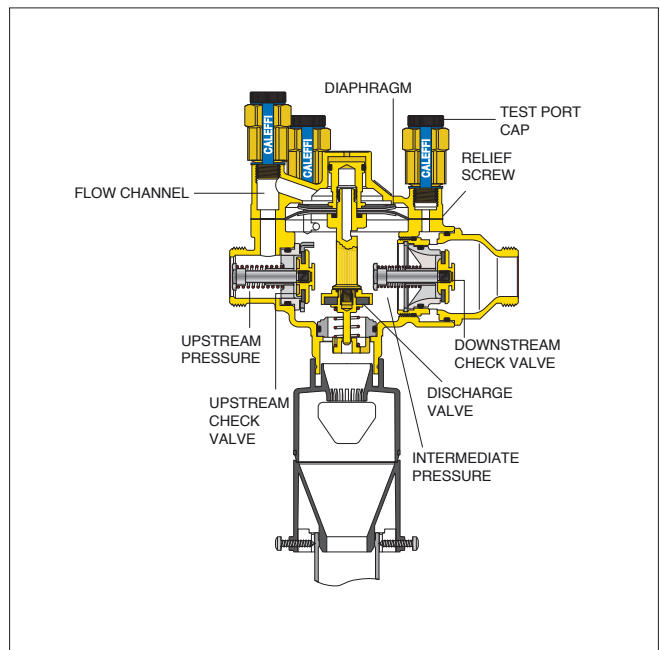

Complies with: ASSE 1013, CSA B64.4, NSF/ANSI 372, Low Lead Laws and listed by ICC-ES. Meets codes IPC, IRC & UPC for use in accordance with the U.S. and Canadian plumbing codes.

BACKFLOW PREVENTERS, RPZ TYPE, FOR PLUMBING AND HYDRONICS

NEW

**574
RPZ Backflow Preventer**



Testable reduced pressure zone backflow preventer.
DZR low lead brass body.
Max. working pressure: 150 psi.
Max. working temperature: 150°F.

Code	Description	Lbs	USD
574700A	1¼" FNPT	14	689.00
574706A	1¼" press	14	784.00

Complies with: ASSE 1013, CSA B64.4, NSF/ANSI 372, Low Lead Laws and listed by ICC-ES. Meets codes IPC, IRC & UPC for use in accordance with the U.S. and Canadian plumbing codes.

Construction details 1¼" RPZ Backflow Preventer

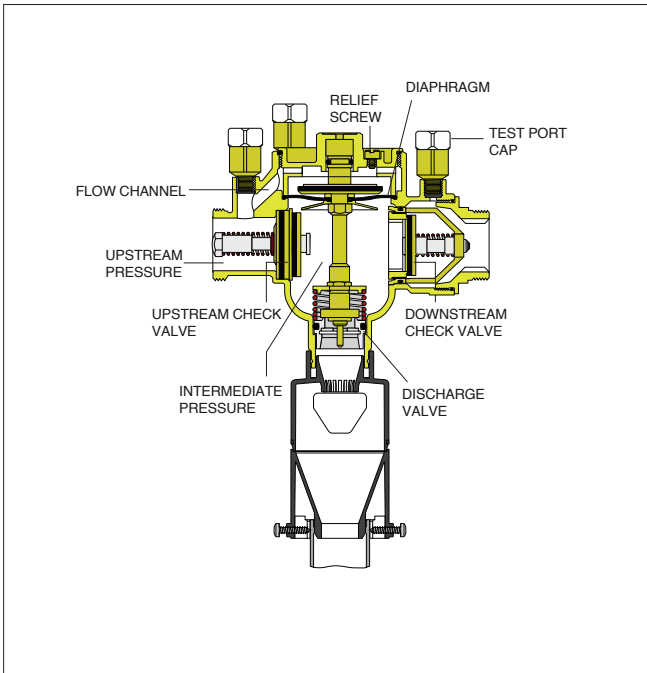

Installation

The installation of backflow preventer should only be carried out by qualified personnel in accordance with applicable codes and regulations.

The backflow preventer includes an upstream and downstream shut-off valve. Install the unit in an accessible area which is not susceptible to accidental flooding. The equipment is to be installed horizontally only. The air gap must be connected in accordance with local codes. See page 9 and 10 for discharge extension pipe size and type, sourced separately.

Before installing the backflow preventer the pipe should be cleaned with a high-capacity water jet.

In order to protect the public supply system the backflow preventer is installed after the water meter and, to protect supplies for sanitary purposes in the internal system, it is installed where contamination can take place, eg: centralized heating systems, garden watering systems etc.

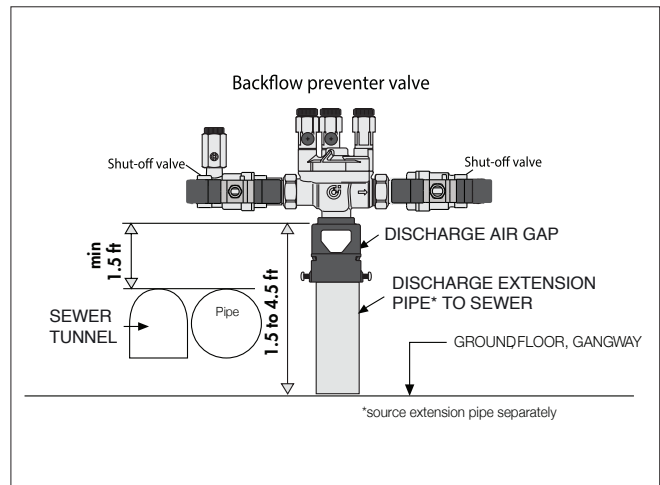

Maintenance

Since the backflow preventer valve is used to ensure the safety of domestic water supplies it must be inspected per local codes. The first sign that the equipment is not functioning properly, generally associated with the presence of sand or other impurities, is indicated by a permanent leakage through the discharge. This loss is just an initial warning sign and does not completely jeopardize the safety of the check mechanism but means that the unit should be dismantled and the equipment should be cleaned. In the event of dripping at the discharge it is recommended to create strong circulation flow for a few minutes by opening one or more taps. This is usually sufficient to flush out any sand or other impurities to restore normal operation.

FAST FILL ACCURATE PRESSURE CONTROL



The highly regarded and widely used AutoFill™ is known among contractors as THE set-it-and-forget-it hydronic system pressure control valve solution. The fast-fill function makes filling the system quicker and simpler by automatically opening fully until fill pressure is reached. System pressure is automatically and accurately maintained per the simple set point dial or the integral shutoff valve can be closed for system isolation from the make-up supply. For flexibility in meeting regional code variations, the AutoFill Combo is available either with an ASSE 1012 dual check type or an ASSE 1013 RPZ type backflow preventer. **CALEFFI GUARANTEED.**



FILLING UNITS AND BOILER TRIM KITS

This diagram is for illustration purposes only

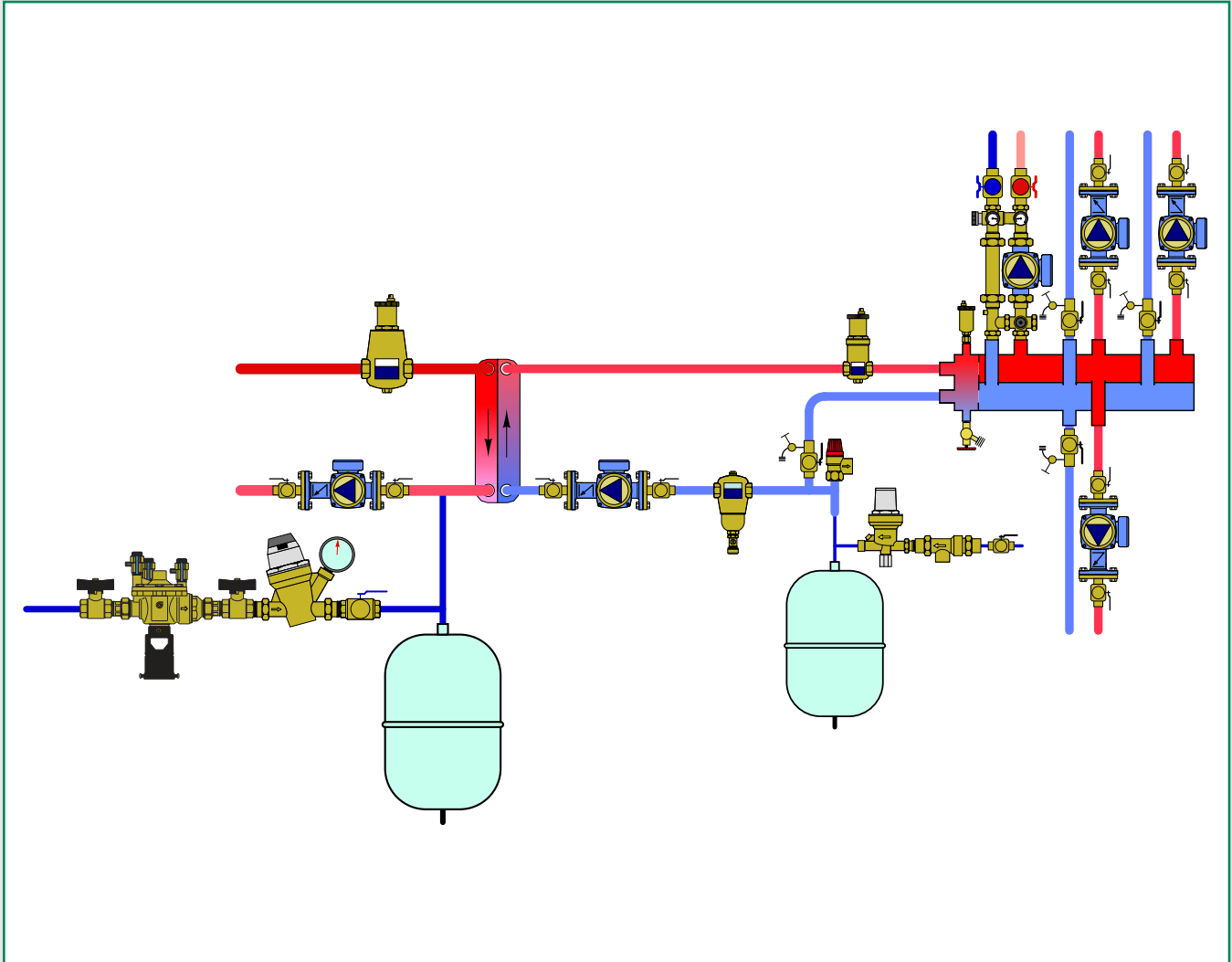

PRODUCTS INCLUDED IN SECTION

- Water treatment filling units
- Fill and flush cart
- Automatic filling units
- Boiler trim kits

WATER TREATMENT FILLING UNITS



NA573

Replenishment water treatment filling unit, demineralizes site water through a color changing (indicates when to change) demineralizing cartridge.
 Max. inlet pressure: 125 psi.
 Max. working temperature: 100°F.
 Max. flow: 1 gpm.
 TDS of water after treatment: < 30 ppm.

Code	Description	Lbs	USD
NA573022*	1/2" FNPT	7.4	334.00
NA573100**	Replacement filter housing assembly	3.4	151.00
NA573102	Replacement color-changing filter	1.0	77.50

*Complete including back flow preventer, isolation valves, filter housing unit with replaceable resin cartridge and AutoFill™.
 **Filter housing only. Includes color changing demineralizing cartridge.

Function

The replenishment water treatment filling unit is an assembly consisting of a backflow preventer, isolation valves, filter housing unit with replaceable resin cartridge and AutoFill™ pre-adjustable fill valve. This unit is installed on the water inlet piping in sealed hydronic heating or cooling systems. Three important functions are provided in this single filling unit assembly: maintaining the pressure of the system stable at a set value and automatically filling up with water as required; protecting drinking water systems from return flow, caused by back-siphoning or back pressure of contaminated fluids; and producing from site-sourced water, demineralized water of an ideal grade for use in closed hydronic heating and cooling systems. Minerals causing hardness are almost entirely eliminated. This prevents premature equipment malfunction including reduced efficiency or component failure due to lime scale formation – a common affliction of heat exchangers. Demineralized water is low in electrical conductivity to minimize corrosion due to galvanic attack. Demineralized water eliminates the variability of mineral content found in untreated site water which provides more reliable dosing when chemical additives are used – such as glycol.

Construction detail

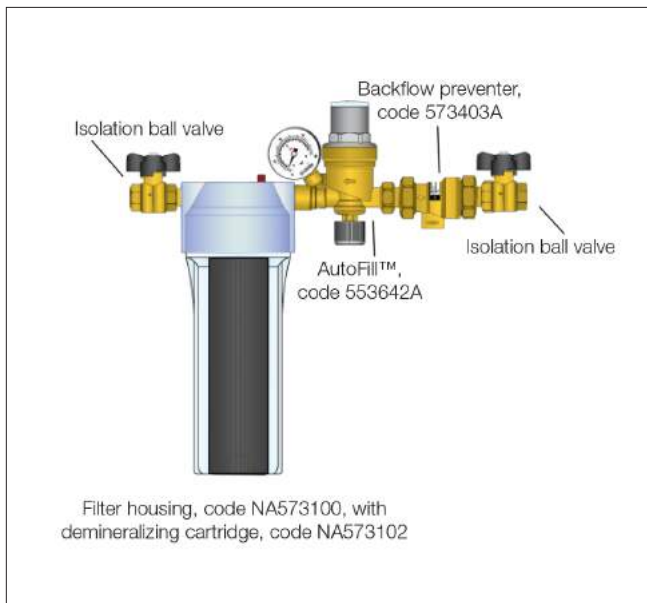

Installation

The replacement water treatment filling unit must be horizontally installed following the direction of flow as indicated by the arrow on the AutoFill™ or 573 backflow preventer body. The replacement water treatment filling unit is factory pre-assembled. Fittings may have loosened during shipping and handle. Check the fittings and tighten accordingly.

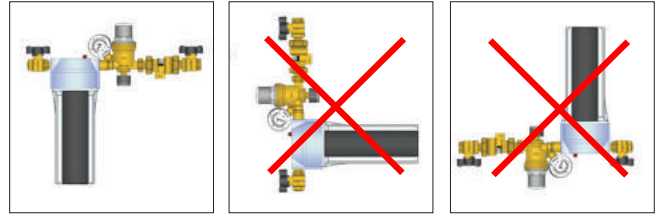

Cartridge change

1. Close the isolation ball valves.
2. Turn the cartridge with white plastic wrench included with unit.
3. Remove the used cartridge and discard them.
4. Insert the new cartridge.
5. Turn the cartridge and tighten in place with the white plastic wrench.
6. Re-open the isolation ball valves to return to normal operation.

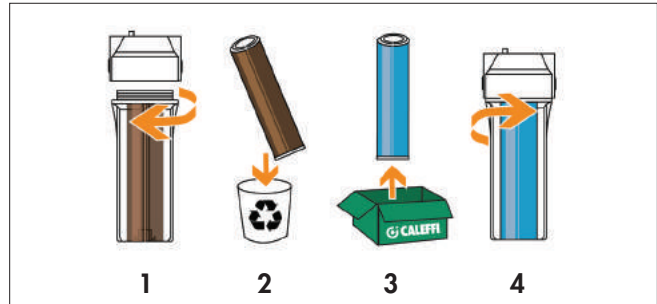

NA570 HYDROFILL™ replacement twist-on lid.

Code	Description	Lbs	USD
NA57094	Replacement twist-on lid	3	549.00

NA570 HYDROFILL™ replacement parts.



Code	Description	Lbs	USD
NA57092	Replacement internal inlet/outlet screens	1.5	50.20
NA57093	Replacement o-ring seal kit	0.1	80.90



Resin bags for NA570 HYDROFILL™ in reusable plastic pail.

Code	Description	Lbs	USD
NA570971	Two resin bags for NA570912	22	404.00
NA570974	Four resin bags for NA570924	43	807.00

FILL AND FLUSH CART

NA255 HYDROFLUSH™



The fill and flush pump cart is portable, leak-tested for a safe, quick and clean way to fill and flush solar, geo thermal and hydronic systems.
 Medium: water, glycol and cleaning fluids.
 Tank: 10 gallon with dirt filter.
 Max. tank medium temperature: 140°F.
 Pump delivery flow: 1–15 gpm.
 Pump feet of head: 125 psi.
 Max. pump pressure: 55 psi.
 Pump power: ½ HP (120 V AC).
 Isolating ball valves: ¾" garden hose thread.
 Transfer hoses: 8' with ¾" GHT (2 ea).
 Dimensions: 48"H x 20"W x 18"D.

Code	Description	Lbs	USD
NA25510	Clean, fill and flush cart	60	2,444.00
NA11338	Replacement hose, 3/4" ID, FxF GHT	3.0	52.00

Dimensions:

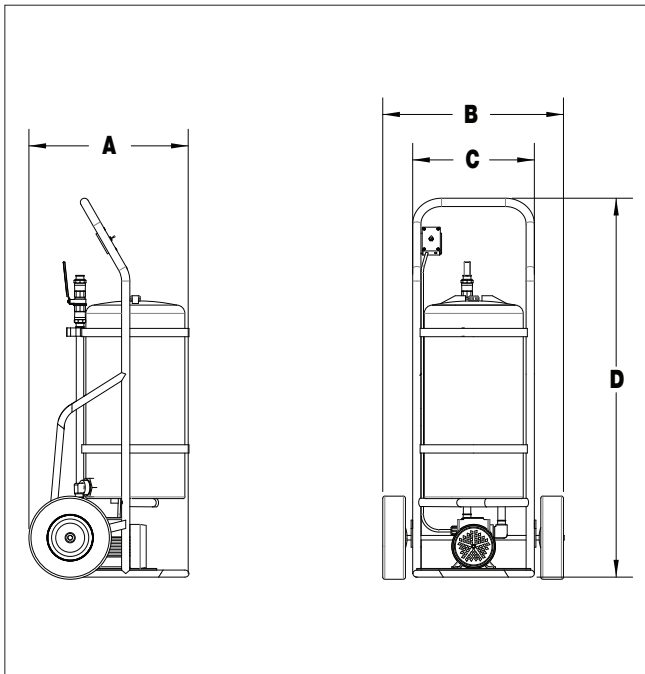

Code	A	B	C	D	Weight	Capacity
NA25510	19 ½"	20 "	14"	46 ¼"	85 lbs.	10 gallon

Function

The fill and flush pump cart is portable and leak-tested for a safe, quick and clean way to fill and flush solar, geothermal and hydronic systems.

Connect the fill/purge valves to the fill and flush system, allow fluid to circulate and remove air and dirt in system.

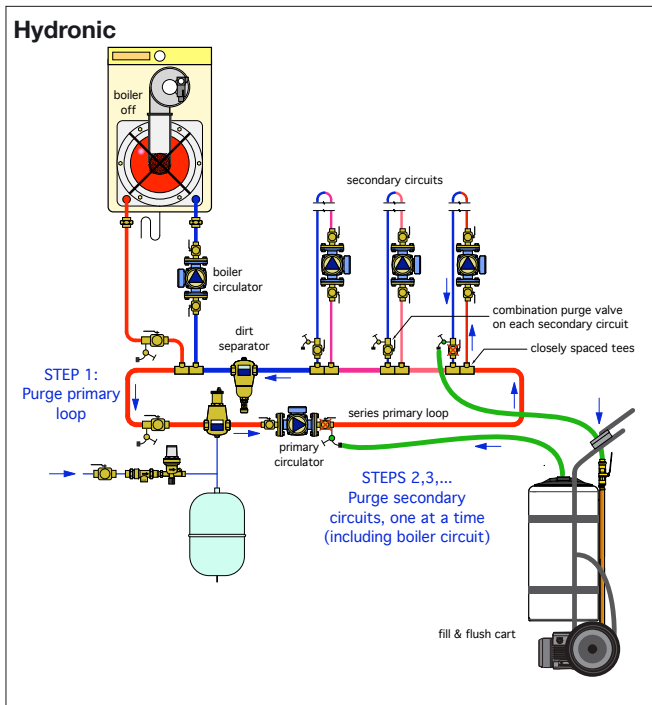
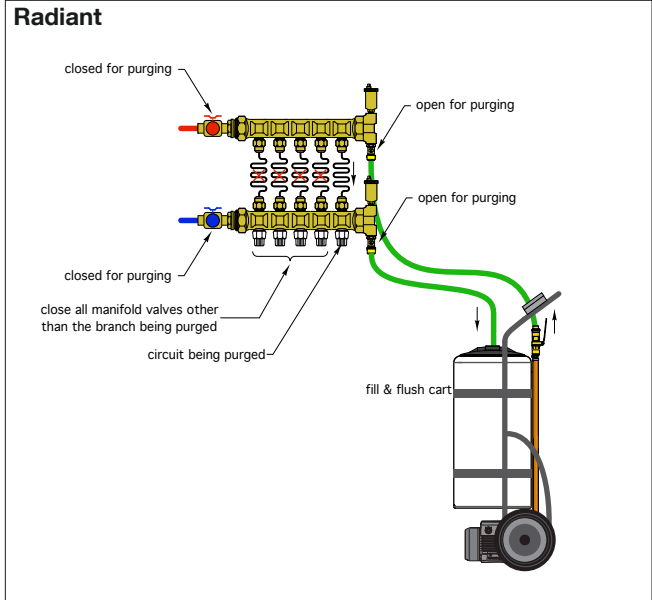

AUTOMATIC FILLING UNITS



553 AutoFill™

Pre-adjustable automatic filling valve, anti-scale, visual system pressure indicator. Complete with manual shut-off valve, strainer and check valve. Brass body.
 Max. inlet pressure: 230 psi.
 Max. working temperature: 150°F.
 Setting pressure range: 3–60 psi.
 Preset outlet pressure: 15 psi.
 Pressure gauge scale: 0–60 psi / 0–4 bar.

Code	Description	Lbs	USD
553542A	½" NPT male union in, ½" FNPT out	1.7	101.00
553549A	½" sweat union in, ½" FNPT out	1.7	95.60
553642A*	½" NPT male union in, ½" FNPT out	1.7	113.00
553649A*	½" sweat union in, ½" FNPT out	1.7	108.00

*With pressure gauge.



573 AutoFill™ Combo

Pre-adjustable automatic filling valve with backflow preventer. Brass body.
 Max. inlet pressure: 175 psi.
 Max. working temperature: 150°F.
 Setting pressure range: 3–60 psi.
 Preset outlet pressure: 15 psi.
 Pressure gauge scale: 0–60 psi / 0–4 bar.

Code	Description	Lbs	USD
573002A	½" NPT female union in, ½" FNPT out	5.0	171.00
573012A*	½" NPT female union in, ½" FNPT out	5.0	185.00
573006A	½" press union in, ½" press out	5.0	191.00
573016A*	½" press union in, ½" press out	5.0	206.00
573007A	½" press union in, ½" FNPT out	5.0	182.00
573017A*	½" press union in, ½" FNPT out	5.0	196.00
573009A	½" sweat union in, ½" FNPT out	5.0	164.00
573019A*	½" sweat union in, ½" FNPT out	5.0	177.00

*With pressure gauge.



574 AutoFill™ Combo

Pre-adjustable automatic filling valve with testable reduced pressure zone backflow preventer. Brass body.
 Max. working pressure: 150 psi.
 Max. working temperature: 150°F.
 Setting pressure range: 3–60 psi.
 Preset outlet pressure: 15 psi.
 Pressure gauge scale: 0–60 psi / 0–4 bar.

Code	Description	Lbs	USD
574002A	½" FNPT	9.4	397.00
574012A	½" FNPT, gauge	9.4	409.00
574206A	½" press	9.4	415.00
574216A	½" press, gauge	9.4	427.00
574207A	½" press in x FNPT out	9.4	406.00
574217A	½" press in x FNPT out, gauge	9.4	418.00



Code	Description	Lbs	USD
NA10363	0-60 psi/0-4 bar, ¼" NPT	0.1	13.00



Code	Description	Lbs	USD
F59650	553 AutoFill™ replacement cartridge	0.2	29.70



Code	Description	Lbs	USD
NA10197	AutoFill™ clear plastic disc cover	0.1	1.30

Application Diagram

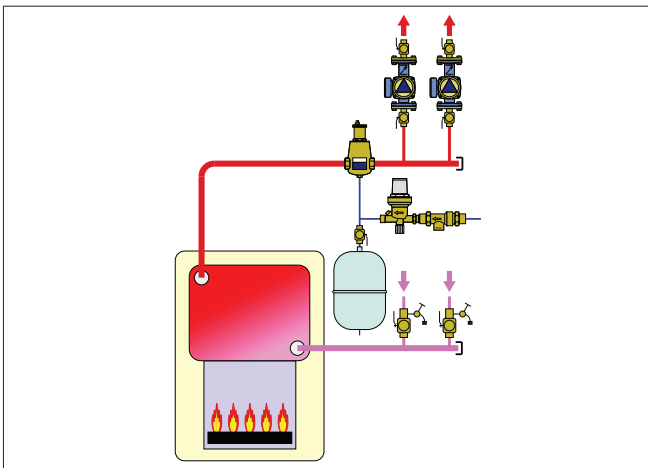

Construction

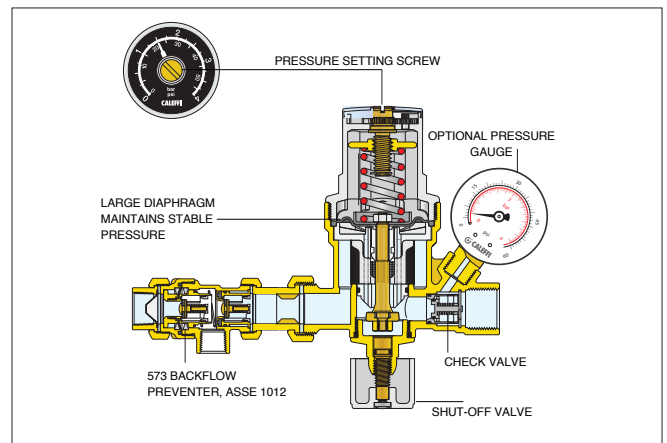

COMMERCIAL AUTOMATIC FILLING UNITS



5350 AutoFill™

Automatic filling valve. Complete with integral downstream pressure gauge and pressure setting adjustment knob. Max. working pressure: 365 psi. Max. working temperature: 140°F. Pressure gauge scale: 0–100 psi /0–7 bar. Pressure setting range: 6–90 psi. Preset outlet pressure: 15 psi.

Code	Description	Lbs	USD
535051A	¾" NPT male union	2.3	131.00
535056A	¾" press union	2.3	134.00
535057A	¾" PEX crimp union	2.3	129.00
535058A	¾" PEX expansion union	2.3	129.00
535059A	¾" sweat union	2.3	129.00
535061A	1" NPT male union	2.4	138.00
535066A	1" press union	2.4	145.00
535067A	1" PEX crimp union	2.4	139.00
535068A	1" PEX expansion union	2.4	139.00
535069A	1" sweat union	2.4	137.00



5350 AutoFill™ Body

Automatic filling valve. Brass body. Complete with integral downstream pressure gauge and pressure setting adjustment knob. See fitting selection table in Section 8.

Code	Description	Lbs	USD
535950A	AutoFill™ body, no fittings	2.0	94.50



574 AutoFill™ Combo

Pre-adjustable automatic filling valve with testable reduced pressure zone backflow preventer. Max. working pressure: 150 psi. Max. working temperature: 140°F. Pressure gauge scale: 0–100 psi /0–7 bar. Pressure setting range: 6–90 psi. Preset outlet pressure: 15 psi.

Code	Description	Lbs	USD
574151A	¾" FNPT in, ¾" NPT male union out	9.4	485.00
574156A	¾" press	9.4	515.00
574157A	¾" press in, ¾" NPT male union out	9.4	500.00



NA102

Pressure gauge fits 5350 series AutoFill™. Dial size: 2". Pressure range: 0–100 psi /0–7 bar. Connection: ½" NPT.

Code	Description	Lbs	USD
NA10273	0-100 psi/0-7 bar, ½" MNPT	0.2	12.30



Replacement cartridge for 5350 series AutoFill™.

Code	Description	Lbs	USD
535004	AutoFill™ 5350 series replacement cartridge	0.2	47.30

BOILER TRIM KITS



NA553

Boiler Trim Kits. 6 configurations combining 8 boiler installation components in one box. This kit includes:

- (1) Caleffi DISCAL® air separator
- (1) Backflow preventer: ½" NPT, sweat or press union
- (1) AutoFill™
- (1) Expansion tank check valve
- (2) Brass nipples: 3"
- (1) NPT brass tee
- (1) Expansion tank

Code	Description	Tank size (gal)	Lbs	USD
NA553362	1" FNPT	4.4	15	480.00
NA553366	1" press	4.4	15	515.00
NA553369	1" sweat	4.4	15	470.00
NA553372	1¼" FNPT	4.4	16	556.00
NA553376	1¼" press	4.4	16	619.00
NA553379	1¼" sweat	4.4	16	546.00



NA553

Boiler Trim Kits. 6 configurations combining 8 boiler installation components in one box. This kit includes:

- (1) Caleffi DISCAL® air separator
- (1) RPZ backflow preventer
- (1) AutoFill™
- (1) Expansion tank check valve
- (2) Brass nipples: 3"
- (1) NPT brass tee
- (1) Expansion tank

Code	Description	Tank size (gal)	Lbs	USD
NA553362R	1" FNPT	4.4	19.4	765.00
NA553366R	1" press	4.4	19.4	801.00
NA553369R	1" sweat	4.4	19.4	756.00
NA553372R	1¼" FNPT	4.4	20.4	842.00
NA553376R	1¼" press	4.4	20.4	905.00
NA553379R	1¼" sweat	4.4	20.4	830.00

PRESS CONNECTIONS AVAILABLE ON ALL OF OUR MOST POPULAR PRODUCTS



Precision engineered with years of proven Caleffi reliability in both plumbing and hydronic product applications. Exclusive leak detection feature reveals leakage point during system testing if a connection remains unpressed.
CALEFFI GUARANTEED.



FITTING CONFIGURATION TABLE

Product series	Code	Description	Nut code	Tailpiece code	Washer code	USD
535H PresCal™ (½")	NA20543	½" FNPT, ¾" nut, washer	incl. w/tail	F49644	incl. w/tail	16.70
533H PresCal™ (½")	NA20540	½" MNPT, ¾" nut, washer	F41186	F31868	R0001458	13.80
553 AutoFill™	NA20549	½" sweat, ¾" nut, washer	F41186	NA10001	R0001458	12.10
127 FlowCal™	NA20643	½" FNPT, 1" nut, washer	F0000698	NA10569	R20011	16.70
	NA20640	½" MNPT, 1" nut, washer	F61008	R31981	R20011	14.50
	NA20640C	½" MNPT, 1" nut, washer, check	F61008	59893A	R20011	22.50
	NA20649	½" sweat, 1" nut, washer	F61008	NA10002	R20011	11.90
	NA20649C	½" sweat, 1" nut, washer, check	F61008	NA10164	R20011	20.10
127 FlowCal+™	NA20646	½" press, 1" nut, washer	F61008	NA10403	R20011	15.40
132 QuickSetter+™	NA20647	½" PEX crimp, 1" nut, washer	F61008	F0000492	R20011	11.90
	NA20647C	½" PEX crimp, 1" nut, washer, check	F61008	NA10484	R20011	20.10
520 TankMixer™	NA20648	½" PEX expansion, 1" nut, washer	F61008	F0001007	R20011	11.90
520 AngleMix™	NA20648C	½" PEX expansion, 1" nut, washer, check	F61008	NA10634	R20011	20.10
521 MixCal™	NA20653	¾" FNPT, 1" nut, washer	incl. w/tail	F49645	incl. w/tail	19.00
	NA20650	¾" MNPT, 1" nut, washer	F61008	31901A	R20011	16.70
5213 TMV (req. inlet port check)	NA20650C	¾" MNPT, 1" nut, washer, check	F61008	59840A	R20011	28.80
5350 AutoFill™	NA20659	¾" sweat, 1" nut, washer	F61008	NA10003	R20011	14.40
	NA20659C	¾" sweat, 1" nut, washer, check	F61008	NA10165	R20011	26.30
533H PresCal™ (¾")	NA20656	¾" press, 1" nut, washer	incl. w/tail	NA16265	R20011	16.80
535H PresCal™ (¾")	NA20656C	¾" press, 1" nut, washer, check	incl. w/tail	NA16265LC	R20011	37.30
	NA20657	¾" PEX crimp, 1" nut, washer	F61008	F0000520	R20011	14.40
5517 DISCAL®	NA20657C	¾" PEX crimp, 1" nut, washer, check	F61008	NA10485	R20011	26.30
6000 LEGIOMIX (3/4")	NA20658	¾" PEX expansion, 1" nut, washer	F61008	F00001008	R20011	14.40
	NA20658C	¾" PEX expansion, 1" nut, washer, check	F61008	NA10635	R20011	26.30
644 Ball Valve	NA20660	1" MNPT, 1" nut, washer	incl. w/tail	59817A	R20011	27.70
676 Zone Valve	NA20660C	1" MNPT, 1" nut, washer, check	incl. w/tail	59894A	R20011	39.70
Z2, Z3 Zone Valve	NA20669	1" sweat, 1" nut, washer	incl. w/tail	59834A	R20011	25.00
	NA20669C	1" sweat, 1" nut, washer, check	incl. w/tail	59906A	R20011	37.00
NA512xx Serviceable check	NA20666	1" press, 1" nut, washer	incl. w/tail	NA16266	R20011	29.00
V40 flow meter	NA20666C	1" press, 1" nut, washer, check	incl. w/tail	NA16266LC	R20011	57.10
	NA20667	1" PEX crimp, 1" nut, washer	F61008	F0000521	R20011	25.00
	NA20667C	1" PEX crimp, 1" nut, washer, check	F61008	NA10486	R20011	37.00
	NA20668	1" PEX expansion, 1" nut, washer	F000698	F0001009	R20011	25.00
535H PresCal™ (1")	NA20668C	1" PEX expansion, 1" nut, washer, check	F000698	NA10636	R20011	37.00
	NA20763	1" FNPT, 1¼" nut, washer	incl. w/tail	F49646	incl. w/tail	26.70
	NA20767	1" PEX crimp, 1¼" nut, washer	R31495	NA10496	R0001454	25.50
	NA20768	1" PEX expansion, 1¼" nut, washer	R31495	NA10556	R0001454	25.00
	5206 AngleMix (1")	NA20766	1" press, 1¼" nut, washer	incl. w/tail	NA10497	R0001454
535H PresCal™ (1¼")	NA20769	1" sweat, 1¼" nut, washer	incl. w/tail	F49657	incl. w/tail	19.70
	NA20873	1¼" FNPT, 1½" nut, washer	incl. w/tail	F49647	incl. w/tail	48.50
	NA20879	1¼" sweat, 1½" nut, washer	R31589	41787 CST	R0001457	43.70
NA513xx Serviceable check	NA20876	1¼" press, 1½" nut, washer	R11221	NA10707	R0001457	64.10
535H PresCal™ (1½")	NA20983	1½" FNPT, 2" nut, washer	incl. w/tail	F0000493	R0001459	73.60
	NA20989	1½" sweat, 2" nut, washer	incl. w/tail	F0000494	R0001459	61.30
	NA20986	1½" press, 2" nut, washer	incl. w/tail	NA10715	R0001459	133.00
535H PresCal™ (2")	NA21193	2" FNPT, 2½" nut, washer	incl. w/tail	F0000495	R0001460	102.00
	NA21199	2" sweat, 2½" nut, washer	incl. w/tail	F0000496	incl. w/tail	111.00
NA514xx Serviceable check	NA21196	2" press, 2½" nut, washer	incl. w/tail	NA10709	R0001460	186.00

FITTING CONFIGURATION TABLE

Product series	Code	Description	Nut code	Tailpiece code	Washer code	USD
548, 5495 Seps (1")	NA20863	1" FNPT, 1½" nut, washer	R31589	31553 FD	R50005	29.90
	NA20869	1" sweat, 1½" nut, washer	R31589	31554 FD	R50005	30.20
	NA20866	1" press 1½" nut, washer	R31589	NA10706	R50005	49.50
548, 5495 Seps (1¼")	NA20973	1¼" FNPT, 2" nut, washer	R53003	31401 FD	R50008	63.50
	NA20979	1¼" sweat, 2" nut, washer	R53003	31403 FD	R50008	84.90
	NA20976	1¼" press 2" nut, washer	R53003	NA10407	R50008	87.10
548, 5495 Seps (1½") 5461 DISCALDIRTMAG™ (1½")	NA21083	1½" FNPT, 2¼" nut, washer	R53004	R41441	R50047	69.20
	NA21089	1½" sweat, 2¼" nut, washer	R53004	41882A	R50047	88.20
	NA21086	1½" press 2¼" nut, washer	R53004	NA10408	R50047	116.00
548, 5495 Seps (2") 5461 DISCALDIRTMAG™ (2")	NA21293	2" FNPT, 2¾" nut, washer	R53005	31426 FD	R50048	107.00
	NA21299	2" sweat, 2¾" nut, washer	R53005	31428 FD	R50048	126.00
	NA21296	2" press 2¾" nut, washer	R53005	NA10409	R50048	171.00
5231 MixCal+™ (1") 6000 LEGIOMIX® (1")	NA20860	1" MNPT 1½" nut, washer	R31589	NA10009	R0001457	33.20
	NA20869	1" sweat, 1½" nut, washer	R31589	31554 FD	R0001457	30.20
	NA20866	1" press, 1-1/2" nut, washer	R31589	NA10706	R0001457	49.50
5231 MixCal+™ (1¼") 6000 LEGIOMIX® (1¼")	NA20870	1¼" MNPT 1½" nut, washer	R31589	R41660	R0001457	58.40
	NA20879	1¼" sweat, 1½" nut, washer	R31589	41787 CST	R0001457	43.70
	NA20876	1-1/4" press, 1-1/2" nut, washer	R11221	NA10707	R0001457	64.10
5231 MixCal+™ (1½") 6000 LEGIOMIX® (1½")	NA21180	1½" MNPT 2½" nut, washer	R51838	41371A	R0001460	97.80
	NA21189	1½" sweat 2½" nut, washer	R51838	41788 CST	R0001460	86.00
	NA21186	1½" press, 2-1/2" nut, washer	R51838	NA10708	R0001460	129.00
5231 MixCal+™ (2") 6000 LEGIOMIX® (2")	NA21190	2" MNPT 2½" nut, washer	R51838	41372A	R0001460	123.00
	NA21199	2" sweat 2½" nut, washer	R51838	41789 CST	R0001460	111.00
	NA21196	2" press, 2-1/2" nut, washer	incl. w/tail	NA10709	R0001460	186.00

SMALL MIXING VALVES, ZONE VALVES, OTHERS WITH 1" UNION FITTINGS



Tail piece with check valve.
Low lead brass.

Code	Description	Lbs	USD
59893A	½" NPT male fits 1" nut	0.2	17.50
59840A	¾" NPT male fits 1" nut	0.3	23.80



Tail piece without check valve.
Low lead brass.

Code	Description	Lbs	USD
R31981	½" NPT male fits 1" nut	0.3	9.30
31901A	¾" NPT male fits 1" nut	0.4	11.70



Tail piece.
Low lead brass. Requires sealing washer R20011, not included.

Code	Description	Lbs	USD
59817A	1" NPT male with 1" nut	0.4	26.30
59894A	1" NPT male with 1" nut w/check valve	0.5	38.30



Tail piece with check valve.
Low lead brass.

Code	Description	Lbs	USD
59904A	½" NPT male fits 1" nut	0.2	15.10
59905A	¾" NPT male fits 1" nut	0.3	21.30



Copper press tail piece with 1" brass union nut. Low lead. Requires sealing washer, not included.

Code	Description	Lbs	USD
NA16264	½" press with 1" union nut	0.3	14.10
NA16265	¾" press with 1" union nut	0.4	15.50
NA16266	1" press with 1" union nut	0.5	27.60



Long copper press tail piece with 1" brass union slip nut. Low lead. Requires sealing washer, not included.

Code	Description	Lbs	USD
NA16265L	¾" long press with 1" union slip nut	0.3	35.50
NA16265LC	¾" long press with 1" union nut/check valve	0.3	45.00
NA16266L	1" long press with 1" union slip nut	0.3	53.00
NA16266LC	1" long press with 1" union nut/check valve	0.3	55.10



Washer fits 1" union thread.

Code	Description	Lbs	USD
R20011	1" union washer	0.1	1.30



Tail piece.
Low lead brass.

Code	Description	Lbs	USD
NA10002	½" sweat fits 1" nut	0.2	6.80
NA10003	¾" sweat fits 1" nut	0.3	9.30



Tail piece.
Low lead brass. Requires sealing washer R20011, not included.

Code	Description	Lbs	USD
59834A	1" sweat with 1" nut	0.4	23.70
59906A	1" sweat with 1" nut w/check valve	0.5	35.70



Tail piece with high temperature check valve.
Low lead brass.

Code	Description	Lbs	USD
NA10164	½" sweat fits 1" nut	0.2	21.00
NA10165	¾" sweat fits 1" nut	0.3	24.60



Tail piece with high temperature check valve.
Low lead brass. Requires sealing washer R20011, not included.

Code	Description	Lbs	USD
NA10166	1" sweat with 1" nut w/check valve	0.4	40.30



Copper press low lead tail piece with check valve, requires F0000698 1" slip nut.

Code	Description	Lbs	USD
NA10419C	¾" press long fits 1" slip nut w/check	0.3	36.00



Copper press low lead tail piece, requires F0000698 1" slip nut.

Code	Description	Lbs	USD
NA10403	½" press fits 1" nut	0.1	18.30
NA10419	¾" press long fits 1" slip nut F0000698	0.3	30.80
NA10404	1" press fits 1" slip nut F0000698	0.4	27.70
NA10786	1" press long fits 1" slip nut F0000698	0.5	46.80



Washer fits 1" union thread.
High temperature silicone rubber.
Working temperature: -40—350°F.

Code	Description	Lbs	USD
NA10302	1" union washer high temp silicone	0.1	2.00

SMALL MIXING VALVES, ZONE VALVES, OTHERS WITH 1" UNION FITTINGS



Union nut fits 1" union thread.

Code	Description	Lbs	USD
F61008	1" brass nut	0.2	3.70
F000698	1" brass slip nut	0.2	5.10



PEX crimp (ASTM F1807) tailpiece for 1" union nut, requires sealing washer and nut, not included.

Code	Description	Lbs	USD
F000492	1/2" PEX for 1" union nut	0.1	6.80
F000520	3/4" PEX for 1" union nut	0.1	9.30
F000521	1" PEX for 1" union nut	0.1	19.90



PEX crimp (ASTM F1807) tailpiece for 1" union nut with check valve, requires sealing washer and nut, not included.

Code	Description	Lbs	USD
NA10484	1/2" PEX for 1" union nut	0.1	15.10
NA10485	3/4" PEX for 1" union nut	0.1	21.30
NA10486	1" PEX for 1" union nut	0.1	31.90



Union nut fits 1" union thread.

Code	Description	Lbs	USD
F61008/C	1" chrome-plated nut	0.2	4.40



Compression fitting.

Code	Description	Lbs	USD
F000718	3/8" compression tailpiece for 1" nut	0.1	13.70



PEX expansion (ASTM F1960) tailpiece for 1" union nut, requires sealing washer and nut, not included.

Code	Description	Lbs	USD
F001007	1/2" PEX for 1" union nut	0.1	6.80
F001008	3/4" PEX for 1" union nut	0.1	9.30
F001009	1" PEX for 1" union nut	0.1	19.90



PEX expansion (ASTM F1960) tailpiece for 1" union nut with check valve, requires sealing washer and nut, not included.

Code	Description	Lbs	USD
NA10634	1/2" PEX for 1" union nut	0.1	15.10
NA10635	3/4" PEX for 1" union nut	0.1	21.30
NA10636	1" PEX for 1" union nut	0.1	31.90

5231 AND 6000 SERIES MIXING VALVE FITTINGS



Tail piece.
Low lead brass.

Code	Description	Lbs	USD
NA10009	1" NPT male	0.3	36.70
R41660	1 1/4" NPT male	0.3	42.00
41371A	1 1/2" NPT male	0.4	47.30
41372A	2" NPT male	0.5	61.30



Tail piece.
Low lead brass.

Code	Description	Lbs	USD
31554 FD	1" sweat	0.3	29.10
41787 CST	1 1/4" sweat	0.3	28.70
41788 CST	1 1/2" sweat	0.4	45.40
41789 CST	2" sweat	0.5	59.10



Large press tail piece.
Low lead brass.

Code	Description	Lbs	USD
NA10706	1" press tailpiece assy	0.4	36.70
NA10707	1 1/4" press tailpiece assy	0.4	67.30
NA10708	1 1/2" press tailpiece assy	0.5	95.90
NA10709	2" press tailpiece assy	0.5	171.00



Union nut.

Code	Description	Lbs	USD
F61008*	1" brass nut	0.2	3.70
F000698*	1" brass slip nut	0.2	5.10
R31589**	1 1/2" union nut	0.2	12.50
R11221	1 1/2" slip union nut for 1-1/4" press	0.2	12.20
R51838***	2 1/2" union nut	0.3	30.50

*Fits 3/4" valves
** Fits 1" and 1 1/4" valves
*** Fits 1 1/2" and 2" valves



Washer.

Code	Description	Lbs	USD
R0001462*	1" union washer	0.1	1.30
R0001457**	1 1/2" union washer	0.1	2.90
R0001460***	2 1/2" union washer	0.1	13.60

* Fits 3/4" valves
** Fits 1" and 1-1/4" valves
*** Fits 1-1/2" and 2" valves

PRESCAL™ PRESSURE REDUCING VALVE FITTINGS



NPT female tailpieces with union nut and washer.

Code	Description	Lbs	USD
F49644	1/2" NPT female tailpiece with 3/4" union nut	0.4	16.30
F49645	3/4" NPT female tailpiece with 1" union nut	0.5	18.40
F49646	1" NPT female tailpiece with 1 1/4" union nut	0.6	24.50
F49647	1 1/4" NPT female tailpiece with 1 1/2" union nut	0.7	40.80
F0000493	1 1/2" NPT female tailpiece with 2" union nut	0.9	73.40
F0000495	2" NPT female tailpiece with 2 1/2" union nut	1.0	87.70



PEX expansion tailpieces (ASTM F1960) for union nut.

Code	Description	Lbs	USD
F0001008	3/4" PEX expansion tailpiece for 1" union nut	0.1	9.30
NA10556	1" PEX expansion tailpiece for 1 1/4" union nut	0.2	12.20



NPT male tailpieces for union nut.

Code	Description	Lbs	USD
F31868	1/2" NPT male tailpiece for 3/4" union nut	0.1	9.70
31901A	3/4" NPT male tailpiece for 1" union nut	0.1	11.70



PEX crimp tailpieces (ASTM F1807) for union nut.

Code	Description	Lbs	USD
F0000520	3/4" PEX crimp tailpiece for 1" union nut	0.1	9.30
NA10496	1" PEX crimp tailpiece for 1 1/4" union nut	0.2	22.40



Sweat tailpieces.

Code	Description	Lbs	USD
NA10001	1/2" sweat tailpiece for 3/4" union nut	0.1	8.10
NA10003	3/4" sweat tailpiece for 1" union nut	0.2	9.30
F49657*	1" sweat tailpiece with 1 1/4" nut	0.4	16.30
41787 CST	1 1/4" sweat tailpiece for 1 1/2" union nut	0.3	28.70
F0000494*	1 1/2" sweat tailpiece with 2" union nut	0.7	55.10
F0000496*	2" sweat tailpiece with 2 1/2" union nut	0.8	75.50

*With washer



Union nut.

Code	Description	Lbs	USD
F41186	3/4" union nut for 1/2" 535H	0.1	3.00
F61008	1" union nut for 3/4" 535H	0.2	3.70
R0000915	1" slip union nut for 3/4" 535H NEW	0.2	3.70
R31495	1-1/4" union nut for 1" 535H	0.3	6.10
R11222	1-1/4" slip union nut for 1" 535H NEW	0.3	6.10
R31589	1-1/2" union nut for 1-1/4" 535H	0.4	12.50
R53003	2" union nut for 1-1/2" 535H	0.4	24.90
R51838	2-1/2" union nut for 2" 535H	0.5	30.50



Press tailpieces.

Code	Description	Lbs	USD
NA16265	3/4" press tailpiece with 1" nut	0.2	15.50
NA10497	1" press tailpiece with 1 1/4" union nut	0.4	30.60
NA10707	1 1/4" press tailpiece for 1 1/2" union nut	0.6	67.30
NA10715	1 1/2" press tailpiece with 2" union nut	0.8	133.00
NA10709	2" press tailpiece with 2 1/2" union nut	0.9	171.00



Union washers.

Code	Description	Lbs	USD
R0001458	3/4" union washer for 1/2" 535H	0.1	1.20
R20011	1" union washer for 3/4" 535H	0.1	1.30
R0001454	1-1/4" union washer 1" 535H	0.1	2.00
R0001457	1 1/2" union washer for 1 1/4" 535H	0.1	2.90
R0001459	2" union washer for 1 1/2" 535H	0.1	5.80
R0001460	2 1/2" union washer for 2" 535H	0.1	13.60

AUTOFILL™ FITTINGS



AutoFill™ union nut.

Code	Description	Lbs	USD
F41186	¾" union nut	0.1	3.00



AutoFill™ tail piece.

Code	Description	Lbs	USD
NA10001	½" sweat	0.3	8.10



AutoFill™ tail piece.

Code	Description	Lbs	USD
F31868	½" NPT male	0.1	9.70



AutoFill™ washer.

Code	Description	Lbs	USD
R0001458	¾" union washer	0.1	1.20

BACKFLOW PREVENTER FITTINGS



Tail piece with screen fits 573 backflow preventer.

Code	Description	Lbs	USD
R0000892	½" NPT female	0.1	12.20



Tail piece with screen fits 573 backflow preventer.

Code	Description	Lbs	USD
41380A	½" sweat	0.1	11.60



Washer union fits 573 backflow preventer.

Code	Description	Lbs	USD
R0001461	Union washer	0.1	2.90

SEPARATOR FITTINGS



Tail piece for steel 548, 5495, 5461.

Code	Description	Lbs	USD
31553 FD	1" NPT female, fits 54...6A	0.3	14.60
31401 FD	1¼" NPT female, fits 54...7A	0.3	32.80
R41441	1½" NPT female, fits 54...8A	0.3	31.70
31426 FD	2" NPT female, fits 54...9A	0.4	64.70



Tail piece for steel 548, 5495, 5461.

Code	Description	Lbs	USD
31554 FD	1" sweat, fits 54...6A	0.3	29.10
31403 FD	1¼" sweat, fits 54...7A	0.3	54.30
41882A	1½" sweat, fits 54...8A	0.3	51.30
31428 FD	2" sweat, fits 54...9A	0.4	84.40



Press tail piece for steel 548, 5495, 5461.

Code	Description	Lbs	USD
NA10406	1" press, fits 54...6A	0.6	37.60
NA10407	1¼" press, fits 54...7A	0.7	56.20
NA10408	1½" press, fits 54...8A	0.9	79.30
NA10409	2" press, fits 54...9A	1.0	130.00



Union nut for steel 548, 5495, 5461.

Code	Description	Lbs	USD
R31589	fits 54...6A	0.4	12.50
R53003	fits 54...7A	0.4	24.90
R53004	fits 54...8A	0.4	24.90
R53005	fits 54...9A	0.4	28.50



Union washer for steel 548, 5495, 5461.

Code	Description	Lbs	USD
R50005	fits 54...6A	0.2	2.90
R50008	fits 54...7A	0.2	5.80
R50047	fits 54...8A	0.2	11.60
R50048	fits 54...9A	0.2	14.10

FITTINGS WITH 3/4" THREADS



Double nipple.

Code	Description	Lbs	USD
NA12172	3/4" NPT x 3/4" NPT	0.3	17.60



Union nut.

Code	Description	Lbs	USD
F41186	3/4" union nut	0.1	3.00

FITTINGS WITH 1" THREADS



Double nipple.

Code	Description	Lbs	USD
NA12173	1" NPT x 1" NPT	0.4	21.90



Bushing.

Code	Description	Lbs	USD
NA10060	3/4" NPT female w/ 1" male thread	0.3	17.60



Sweat adapter.

Code	Description	Lbs	USD
NA10061	3/4" sweat adaptor w/ 1" male thread	0.2	18.40



Sweat adapter.

Code	Description	Lbs	USD
NA10062	1" sweat adaptor w/ 1" male thd.	0.1	19.00



Union nut fits 1" union thread.

Code	Description	Lbs	USD
F61008	1" brass nut	0.2	3.70
F000698	1" brass slip nut	0.2	5.10

FITTINGS WITH 1" THREADS



Nipple.

Code	Description	Lbs	USD
NA12162	¾" male w/ O-ring x 1" male thread	0.2	20.30



Bushing.

Code	Description	Lbs	USD
NA10089	¾" female thread x 1" male thread	0.1	14.70



Disk.

Code	Description	Lbs	USD
NA10104	1" female disk	0.1	3.00



High temperature silicone flat 1" washer.

Code	Description	Lbs	USD
NA10302	1" flat silicone gasket	0.1	2.00



Nipple.

Code	Description	Lbs	USD
NA10064	1" NPT w/ 1" male thread	0.2	19.80

FITTINGS WITH 1¼" THREADS



Sweat adapter.

Code	Description	Lbs	USD
NA10119	1" sweat adapter x 1¼" union thread	0.4	24.20



Bushing.

Code	Description	Lbs	USD
NA10087	1" female x 1¼" male thread bushing	0.4	17.70



Bushing.

Code	Description	Lbs	USD
61215A	1" NPT F x 1¼" M thread bushing	0.8	17.60



Nipple.

Code	Description	Lbs	USD
R31706	1" male x 1¼" male nipple	0.3	21.90



Union nut.

Code	Description	Lbs	USD
R31495	1¼" union nut	0.1	6.10



Washer.

Code	Description	Lbs	USD
R0001454	1¼" washer	0.1	2.00



Disk.

Code	Description	Lbs	USD
R11059	1¼" female disk	0.1	3.70

MISCELLANEOUS SYSTEM COMPONENTS



519

Differential pressure by-pass valve. Adjustable from 2 to 10 psid. Brass body. Max. working pressure: 150 psi. Working temperature range: 32 – 230°F. ¾" flow up to 9 gpm. 1" flow up to 40 gpm. 1¼" flow up to 45 gpm.

Code	Description	Lbs	USD
519502A	¾" NPT female union	1.0	108.00
519566A	¾" press union	1.0	122.00
519599A	¾" sweat union	1.0	107.00
519600A	1" FNPT in, 1" NPT male union out	1.4	168.00
519609A	1" FNPT in, 1" sweat union out	1.4	168.00
519700A	1¼" FNPT in, 1¼" NPT male union out	1.5	202.00
519709A	1¼" FNPT in, 1¼" sweat union out	1.5	202.00



538

Drain valve. Brass body. ¾" garden hose thread with cap. Max. working pressure: 150 psi. Max. working temperature: 250°F.

Code	Description	Lbs	USD
538202 FD	¼" NPT male x ¾" GHT	0.3	12.20
538402 FD	½" NPT male x ¾" GHT	0.3	12.50



NA503

Tridicator dual pressure / temperature gauge for boilers. Dial size: 3 1/8". Pressure range: 0–75 PSI. Temperature range: 60–320°F. ¼" NPT rear probe. For direct fluid stream submersion.

Code	Description	Lbs	USD
NA503040	¼" NPT male center back	0.2	30.50

NEW



Isolation ball valve. Low lead MxF union fits 1" valves between body and tailpiece.

Code	Description	Lbs	USD
290030	Isolation ball valve 1" M x 1" F union	1	35.00

UNIVERSAL FLOW SWITCH



626 Uni-Switch™

Universal flow switch. Suitable for 1" to 8" pipe size. Working pressure: 150 psi. Working temperature range: -20 – 250°F. Minimum flow: 5.7 gpm. Switch contacts: NO or NC. Switch rating: 15 A. CE, cUL, NEMA Type 5, IP 54.



Code	Description	Lbs	USD
626600A	1" NPT male thread	2.3	210.00
626009	Replacement paddle assembly*	0.1	19.70

* stainless steel

Installation

The unit is equipped with a set of paddles (blades) (1), to be used for different pipe diameters, particularly sized to allow easy installation and minimal head losses.

For diameters equal to or greater than 3" (DN 80), it is necessary to add to the preassembled blades in increasing order on the long blade (2) (supplied in the package), just by cutting it to the size corresponding to the desired diameter. Replacement paddle or blade assemblies are available, order part number 626009.

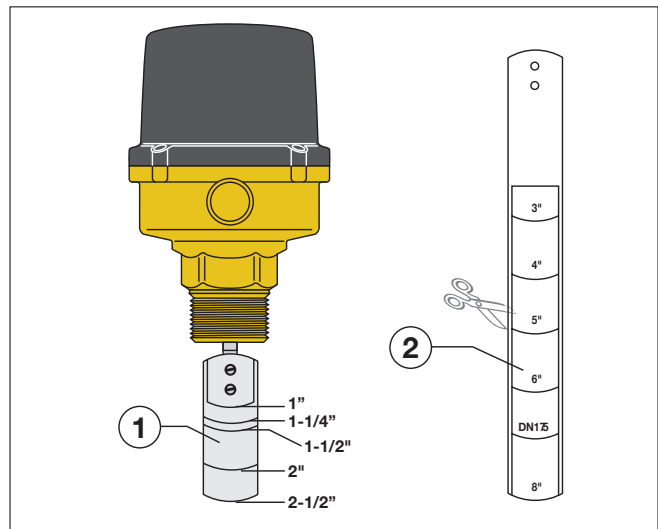

SERVICEABLE LOW LEAD CHECK VALVES

NA51



Serviceable low lead check valves.
 Max. working pressure: 150 psi (10 bar).
 Operating temperature range: 32 to 150°F (0 to 65°C).
 Max. temperature: for one hour: 190°F (88°C).
 Opening pressure differential: 0.25 psi (1/2" through 1 1/4"); 0.50 psi (1 1/2", 2").

Code	Description	Cv	Lbs	USD
NA51200	Body, small, w/o fittings	17	0.2	44.90
NA51240	1/2" MNPT	17	0.4	75.50
NA51243	1/2" FNPT	17	0.4	85.70
NA51246	1/2" press	17	0.4	91.80
NA51247	1/2" PEX crimp	17	0.4	69.40
NA51248	1/2" PEX expansion	17	0.4	69.40
NA51249	1/2" sweat	17	0.4	63.20
NA51250	3/4" MNPT	17	0.6	79.60
NA51253	3/4" FNPT	17	0.6	91.80
NA51256	3/4" press	17	0.6	97.90
NA51257	3/4" PEX crimp	17	0.6	75.50
NA51258	3/4" PEX expansion	17	0.6	75.50
NA51259	3/4" sweat	17	0.4	69.40
NA51300	Body, medium, w/o fittings	30	0.5	57.10
NA51360	1" MNPT	30	1.1	104.00
NA51363	1" FNPT	30	1.1	110.00
NA51366	1" press	30	1.1	143.00
NA51369	1" sweat	30	0.9	97.90
NA51370	1 1/4" MNPT	30	1.3	114.00
NA51373	1-1/4" FNPT	30	1.3	120.00
NA51376	1-1/4" press	30	1.3	167.00
NA51379	1 1/4" sweat	30	1.1	110.00
NA51400	Body, large, w/o fittings	75	1.8	149.00
NA51480	1 1/2" MNPT	75	2.6	292.00
NA51486	1 1/2" press	75	2.6	361.00
NA51489	1 1/2" sweat	75	2.4	275.00
NA51490	2" MNPT	75	2.6	310.00
NA51493	2" FNPT	75	2.6	322.00
NA51496	2" press	75	2.6	396.00
NA51499	2" sweat	75	2.4	292.00

Application diagram

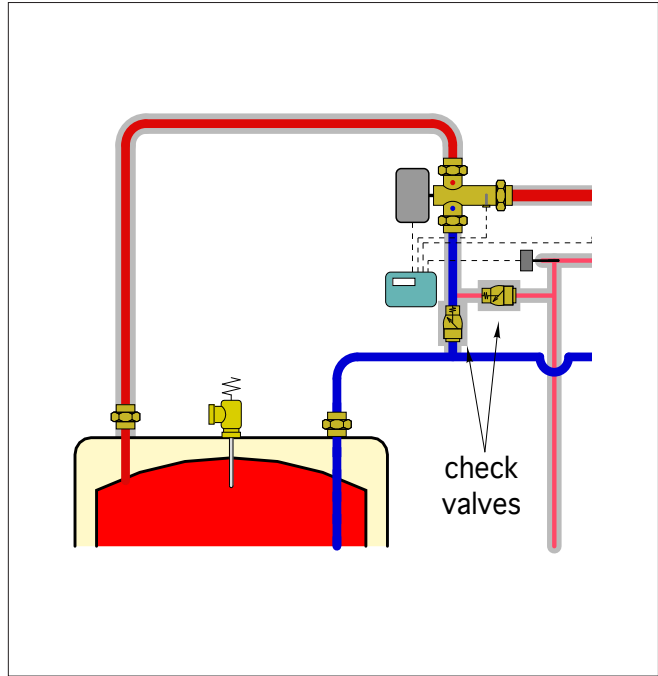

Replacement checks.



Code	Description	Cv	Lbs	USD
NA10117	Fits 1/2", 3/4" (small body)	17	0.1	8.20
NA10370	Fits 1", 1 1/4" (medium body)	30	0.1	8.20
NA10371	Fits 1 1/2", 2" (large body)	75	0.2	14.30

MISCELLANEOUS COMPONENTS

NA101



Ball valve. Brass body.
 Max. working pressure: 600 psi.
 Max. working temperature: 365°F.

Code	Description	Lbs	USD
NA10167	1/2" sweat x 1/2" sweat	0.5	8.20

NA510



NBR, POM check valve.
 Max. percentage of glycol: 50%.
 Max. working pressure: 150 psi.
 Temperature range: 32-150°F (190°F for max. 1 hour).
 Opening pressure differential: 0.25 psi (1/2" through 1 1/4"); 0.50 psi (1 1/2", 2").

Code	Description	Cv	Lbs	USD
NA51059	3/4" sweat union	12	0.7	48.00
NA51069	1" sweat union	17	1.0	61.30

WEBINAR SERIES EXCELLENCE IN EDUCATION



You are invited to join us for our monthly webinar series, Coffee with Caleffi™. The complimentary technical training webinars are intended for contractors, designers and wholesalers. A Certificate of Attendance is emailed to attendees following the webinar for continuing education consideration. Register by scanning the QR code below. Missed a webinar? No problem! Our webinars are available 24/7 on YouTube for your convenience. **CALEFFI GUARANTEED.**

Coffee with Caleffi™
bit.ly/CWC-SCHEDULE

For more information
marketingadmin@caleffi.com

RENEWABLES, SOLAR, GEOTHERMAL AND BIOMASS DEVICES

This diagram is for illustration purposes only

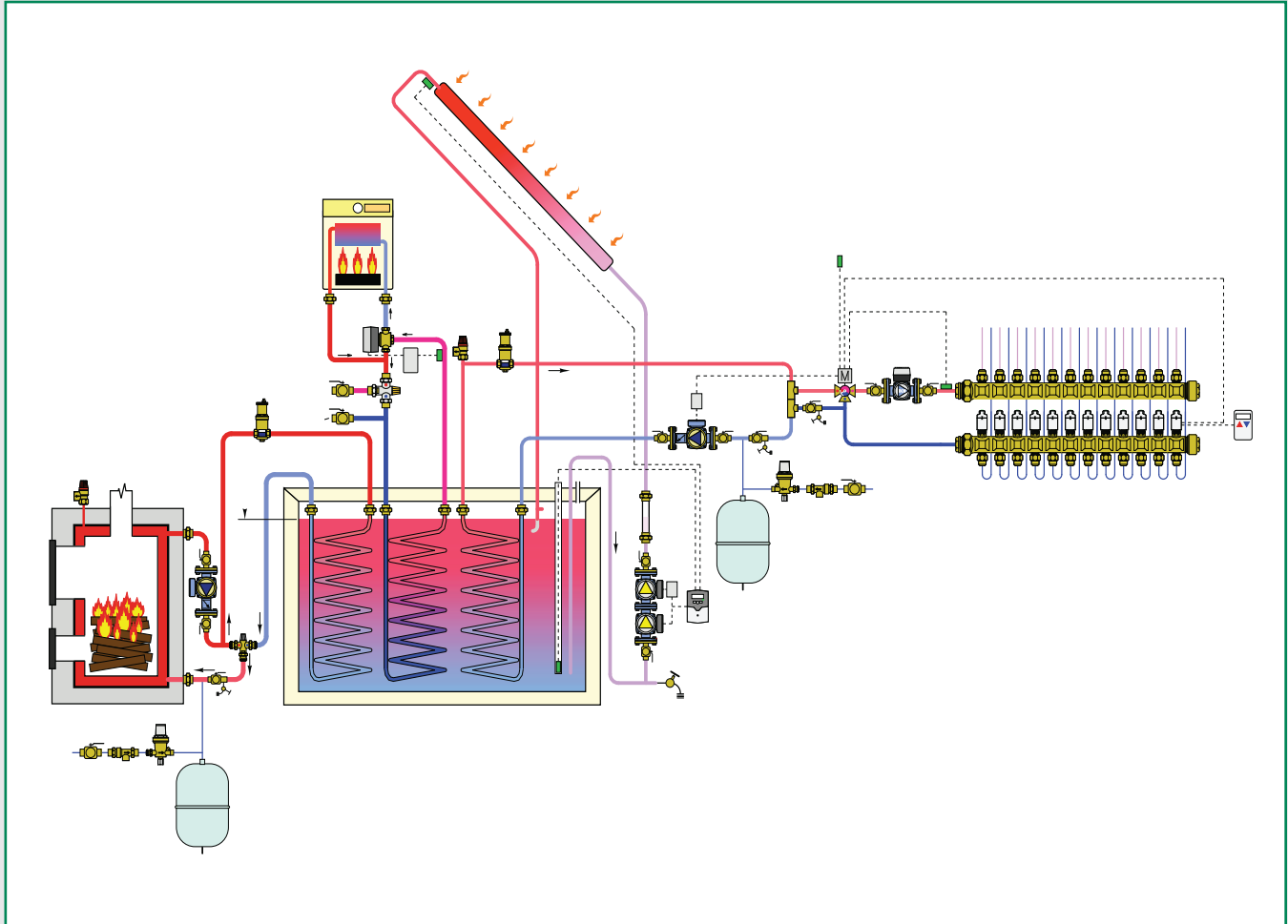

PRODUCTS INCLUDED IN SECTION

- Pump stations and fittings
- Mixing valves
- Air vents, air separator, and safety relief valves
- Geothermal manifolds and fittings
- Geothermal accessories
- Boiler protection valve accessories
- Boiler protection high-flow thermostatic mixing valve
- Boiler protection recirculation and distribution unit

SOLAR PUMP STATIONS

278 & 279



Solar pump stations are pre-assembled and leak-tested. Safety relief valve. Ball valves with built-in flow checks in return (and flow for dual-line models). Temperature gauges in return (and flow for dual-line models). Pressure gauge. Manual air vent (dual-line models only). Expansion tank connection. Connections for flushing and filling. Foam insulation. Balance/flow meter: 1 – 8 gpm scale. Pump: three speed. Pump performance: 19 ft head/8 gpm. Safety relief valve: 90 psi. Max. working pressure: 145 psi. Max. working temp: 350°F. Connections: 3/4" female thread.

(Select adaptors to the right)



Code	Description	Lbs	USD
279051A	Dual-line solar pump station	17	847.00
279051	Dual-line solar station w/o pump	12	677.00
278751A	Single-line solar pump station	14	738.00
278751	Single-line solar station w/o pump	10	569.00
278011	Controller housing	0.5	41.20



Replacement pumps fit current solar pump stations 278 & 279, plus discontinued 255 & 256 stations. 3 speed 115 V. 1" male union thread. Agency approval: cULus.

(install in-line with NA122 union fittings on page 84)

Code	Description	Lbs	USD
NA10481	Grundfos 15-58U, 21' head / 18 gpm	5	218.00



Replacement pump fits solar pump station NA255. 120 VAC / 1.3 A. 30 feet head / 30 gpm. 1 1/2" male union thread.

(install in-line with NA122 union fittings on page 94)

Code	Description	Lbs	USD
NA12169	Wilco Star S 30 replacement pump	6.0	349.00

PUMP STATION FITTINGS



3/4" SolarFlex™ directly to top or bottom. 2 each.

Code	Description	Lbs	USD
NA26650	3/4" male thread x 1" male thread	0.6	40.70



3/4" SolarFlex™ directly to top and bottom. 4 each.

Code	Description	Lbs	USD
NA26750	3/4" male thread x 1" male thread	1.0	81.50



1" SolarFlex™ directly to top or bottom. 2 each.

Code	Description	Lbs	USD
NA26660	3/4" male thread x 1 1/4" male thread	0.6	78.60



1" SolarFlex™ directly to top and bottom. 4 each.

Code	Description	Lbs	USD
NA26760	3/4" male thread x 1 1/4" male thread	1.0	157.00

SOLAR GLYCOL



NA101 SolarHD™

Pre-mixed 50% high temperature non toxic glycol, FDA reference: 21 CFR 182.1666, Gosselin TOXICITY INDEX 1, Generally recognized as safe for use as direct food additives. NSF listed, Category Code: HT1, HT2, NSF Registration No. 144912. Compatible with other propylene glycols.



NSF
National Compound
Program Listed HT1 and HT2
Registration 144912

Code	Description	Lbs	USD
NA10103	5 gallon bucket	45	179.00

PUMP STATION FITTINGS



3/4" sweat fittings to top or bottom.
2 each.

Code	Description	Lbs	USD
NA26659	3/4" male thread x 3/4" sweat fitting	0.6	69.70



3/4" sweat fittings to top and bottom. 4 each.

Code	Description	Lbs	USD
NA26759	3/4" male thread x 3/4" sweat fitting	1.0	139.00



1" sweat fittings to top or bottom.
2 each.

Code	Description	Lbs	USD
NA26669	3/4" male thread x 1" sweat fitting	0.6	76.40



1" sweat fittings to top and bottom. 4 each.

Code	Description	Lbs	USD
NA26769	3/4" male thread x 1" sweat fitting	1.0	152.00

DRAINBACK PUMP STATION

278



Drainback solar pump station designed with a high head and steep pump curve which are pre-assembled and leak-tested. Safety relief valve, ball valve, temperature gauge, pressure gauge, air fill valve. Connections for flushing and filling with foam insulation. Balance/flow meter: 2—8 gpm scale. Pump: Grundfos UP15-100. Performance: 36 feet head / 8 gpm. Safety relief valve: 90 psi. Max. working pressure: 145 psi. Max. working temp: 350°F. Connections: 3/4" female thread. (Select adaptors to the left)

Code	Description	Lbs	USD
278951A	Drainback solar pump station	14	788.00

NA121



Replacement single speed 120 V, 1" male union thread. Flow 36 feet head / 8 gpm. Agency approval: cULus. (install in-line with NA122 union fittings on page 94)

Code	Description	Lbs	USD
NA12171	Grundfos Solar 15-100	6.0	271.00

DC SOLAR PUMP

NA267



12 to 34 VDC, DC Strong solar pump for mounting in solar stations. 15 feet head / 7 gpm at 24 VDC. 12 feet head / 4 gpm at 12 VDC. Power consumption: 30—45 W. Max. working pressure: 150 psi. Max. temperature: -10—230°F.

(install in-line with NA122 union fittings on page 94)



Shown mounted in 279051 or can be mounted inside 278751.

Code	Description	Lbs	USD
NA26711	1" male union thread	3.0	469.00

LOW LEAD MIXING VALVES



2521

Adjustable thermostatic three-way mixing valve for solar systems with built-in inlet check valves.
 Setting range: 80—150°F.
 Max. working pressure: 200 psi.
 Max. inlet temperature: 210°F.
 Connection: ½", ¾", 1" sweat.
 Certified to ASSE 1017, CSA B125.3, UPC, IPC, Low Lead Laws and listed by ICC-ES for use in accordance with the U.S. and Canadian plumbing codes.

Code	Description	Lbs	USD
252149A	½" sweat unions	1.2	163.00
252158A	¾" sweat unions with gauge	1.2	211.00
252159A	¾" sweat unions	1.2	171.00
252168A	1" sweat unions with gauge	1.2	240.00
252169A	1" sweat unions	1.2	199.00



Check valve for use in 2521 mixing valve.
 Max. inlet temperature: 210°F.

Code	Description	Lbs	USD
R29326	Check valve insert	0.1	6.10

Operating principle

The controlling element of the solar thermostatic mixing valve is a temperature sensor that is fully immersed in the mixed water outlet passage. As it expands or contracts, the sensor continuously establishes the correct proportion of hot and cold water entering the valve. The flow is regulated by a piston sliding in a cylinder between the hot and cold water passages. Even when there are pressure drops due to the drawing off of hot or cold water for other uses or variations in the incoming temperature, the mixer automatically regulates the water flow to obtain the required temperature.

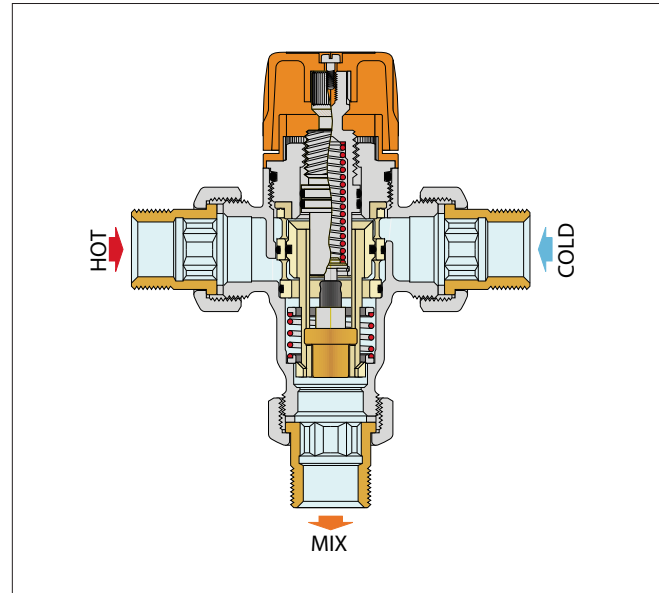

AIR SEPARATOR AND SAFETY RELIEF VALVES



251 DISCAL®

Air separator for solar heating systems.
 Working temperature range: -20—320°F.
 Max. working pressure: 150 psi.
 Max. discharge pressure: 150 psi.
 Connections: Main, ¾" NPT, female.
 Bottom, ½" NPT, female.

Code	Description	Lbs	USD
251003A	¾" NPT female	2.0	150.00



253

Safety relief valves for solar systems.
 Working temperature range: -20—360°F.
 Normal pressure: 150 psi.
 Opening over pressure: 10%.
 Closing differential: 20%.
 Discharge capacity: 171,000 Btu.
 Connections: Inlet, ½" female.
 Discharge, ¾" female.
 TÜV certified to TRD-721-SV100 7.7.
 Meets ANSI Z21.22 standard.

TÜV Rheinland is an approved U.S. Nationally Recognized Testing Laboratory (NRTL) Certification Body for Pressure Equipment. Meets ANSI Z21.22 "Relief Valves for Hot Water Supply Systems."



Code	Description	Lbs	USD
253042	Factory set to 35 psi	0.3	50.50
253043	Factory set to 45 psi	0.3	50.50
253044	Factory set to 60 psi	0.3	50.50
253046	Factory set to 90 psi	0.3	50.50
253048	Factory set to 120 psi	0.3	50.50
253040	Factory set to 150 psi	0.3	50.50

AUTOMATIC AIR VENTS



250

Automatic air vent for solar systems.
Working temperature range: -20—360°F.
Max. working pressure: 150 psi.
Max. discharge pressure: 75 psi.

Code	Description	Lbs	USD
250041A	1/2" FNPT and 3/4" MNPT	0.3	53.20

Function

Automatic air vents are used in the closed circuits of solar heating systems. They allow air contained in the fluid to be released automatically during the filling process, through a valve operated by a float in contact with fluid in the system.

The shut-off valves are used in combination with the automatic air vents to isolate them after filling the circuit of solar heating systems. These series of products have been specially made to work at high temperatures with a glycol medium.

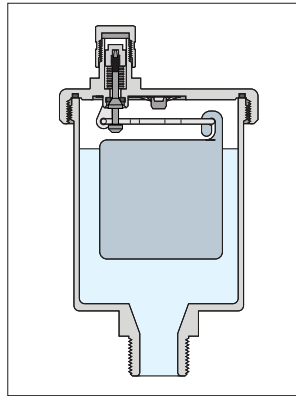

NA292



Shut-off fits automatic air vent.
Working temperature range: -20—360°F.
Max. working pressure: 150 psi.

Code	Description	Lbs	USD
NA29284	1/2" FNPT x 1/2" MNPT	0.2	41.30



251

DISCALAIR®

High-performance automatic air vent for solar heating systems.
Working temperature range: -20—320°F.
Max. working pressure: 150 psi.
Max. discharge pressure: 150 psi.

Code	Description	Lbs	USD
251004A	1/2" MNPT	0.8	113.00

Function

DISCALAIR® solar devices are used in hydronic systems or in the filling and start-up phase of solar heating systems to discharge evenly discharge large quantities of air that have formed in the circuits. This function is performed even when there is considerable pressure due to the special geometry of the discharge mechanism, which is identical to the mechanism on DISCAL® Solar 251 series air separators.

This particular series of automatic air vent valves have been specifically designed to work at high temperature with a glycol medium, which is typical of solar heating systems.

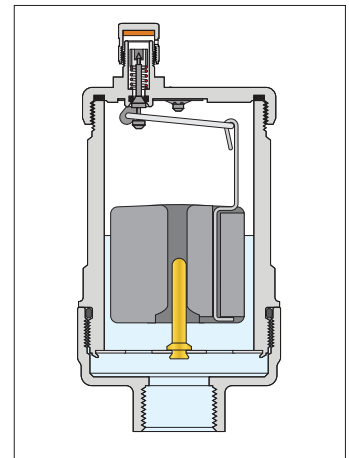

NA102



Vent cap adapter to connect discharge tube. Fits all air vents and air separators except 5026 and 5027 series.

Code	Description	Lbs	USD
NA10204	1/4" MNPT	0.1	17.60

MANIFOLDS

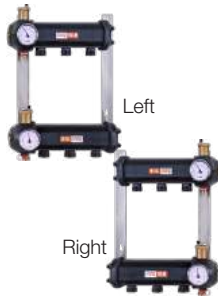

**110
GeoCal™**

GeoCal™ left or right hand distribution manifold assemblies with temperature gauges, air vents and drain valves. 1¼" F NPT brass inlet/outlet ports. Max. working pressure: 90 psi. Max. system test pressure: 150 psi. Working temperature range for: water, glycol & saline solutions: 15–140°F. Ethanol & methanol solutions: 15–90°F. Ambient temp. range: -5–140°F. Max. flow rate: 24 gpm total all circuits.

Code	Description	Lbs	USD
1107B5LA	Left side connections, 2 circuits	16	777.00
1107B5RA	Right side connections, 2 circuits	16	777.00
1107C5LA	Left side connections, 3 circuits	18	858.00
1107C5RA	Right side connections, 3 circuits	18	858.00
1107D5LA	Left side connections, 4 circuits	20	945.00
1107D5RA	Right side connections, 4 circuits	20	945.00
1107E5LA	Left side connections, 5 circuits	22	1,024.00
1107E5RA	Right side connections, 5 circuits	22	1,024.00
1107F5LA	Left side connections, 6 circuits	23	1,105.00
1107F5RA	Right side connections, 6 circuits	23	1,105.00
1107G5LA	Left side connections, 7 circuits	25	1,204.00
1107G5RA	Right side connections, 7 circuits	25	1,204.00
1107H5LA	Left side connections, 8 circuits	26	1,283.00
1107H5RA	Right side connections, 8 circuits	26	1,283.00



NA102

GeoGrip™ manifold outlet connector for joining manifold to polyethylene pipe. (Includes union nut and gasket)

Code	Description	Lbs	USD
NA10246	¾" PE pipe compression	0.8	32.70
NA10247	1" PE pipe compression	1.0	40.50

FITTINGS



110

GeoCal™ manifold outlet fitting, includes union nut and gasket.

Code	Description	Lbs	USD
110050A	¾" male NPT tail piece	0.4	25.30
110060A	1" male NPT tail piece	0.6	27.70



861

GeoGrip™ polyethylene pipe fittings. For joining polyethylene pipe to 132 series QuickSetter™.

Code	Description	Lbs	USD
861527A CST	¾" M NPT x ¾" PE pipe compression	0.2	15.40
861634A CST	1" M NPT x 1" PE pipe compression	0.6	24.70
NA10288	¾" M NPT x 1" PE pipe compression	0.2	34.40

GEOHERMAL ACCESSORIES



132

QuickSetter™ balancing valve with flow meter. Direct reading of flow rate. Brass valve body and flow meter. Graduated scale flow meter with magnetic movement flow rate indicator. Max. working pressure: 150 psi. Temperature range: 14–230°F. Max. percentage of glycol: 50%.

Code	Description	Flow scale (gpm)	Lbs	USD
132552A	¾" FNPT	2.0–7.0	1.8	181.00
132662A	1" FNPT	3.0–10.0	2.4	211.00
132772A	1¼" FNPT	5.0–19.0	2.8	281.00
132882A	1½" FNPT	8.0–32.0	3.4	333.00
132992A	2" FNPT	12.0–50.0	4.4	407.00
F19346	Replacement by-pass valve stem*		0.1	34.00

* With operating ring

BOILER PROTECTION ACCESSORIES



F296

Replacement thermostatic sensor cartridges. Sensor cartridge accuracy: ±4°F. By-pass from boiler complete closing temperature: Tset +18°F (130°+18°=148°F).

Fits 280 and 281 series boiler protection valves. Easy replacement to change the 280 valve set temperature without removing the valve body from the piping.

Code	Description	Lbs	USD
F29633	115°F Tset	0.2	25.80
F29634	130°F Tset	0.2	25.80
F29635	140°F Tset	0.2	25.80
F29636	160°F Tset	0.2	25.80

Selection note: thermostatic sensor cartridge will completely close at Tset value +18°F. Example: (130°F Tset +18°F=148°F completely closed) ±4°F.



F295

Dual scale temperature gauge 280 and 281 series boiler protection valves.

Code	Description	Lbs	USD
F29571	32–250°F	0.2	21.80

BOILER PROTECTION HIGH-FLOW THERMOSTATIC MIXING VALVES



280 ThermoProtec™

Boiler protection high-flow thermostatic mixing valve. Changeable thermostatic sensor cartridge. Brass body and lower plug. Max. working pressure: 150 psi. Working temperature range: 40–212°F. Thermostatic sensor cartridge: 130°F & 140°F Tset standard selections, see below. 115°F, 160°F Tset optional (field replaceable). Sensor cartridge accuracy: ±4°F. By-pass from boiler complete closing temperature: Tset +18°F (ex. 130°+18°=148°F).

Construction

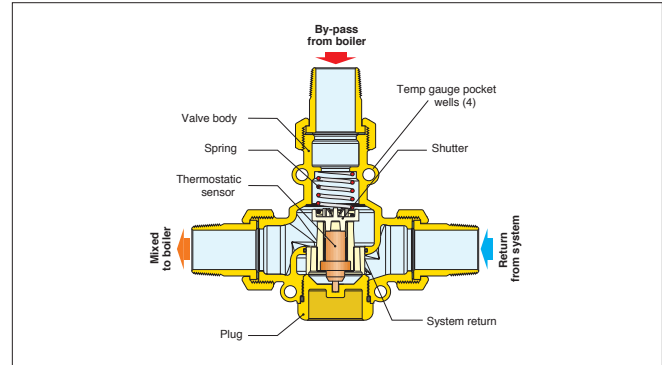

Code	Description	Lbs	USD
280965A	1" sweat unions 130°F Tset	11	255.00
280165A	1" NPT female unions 130°F Tset	11	272.00
280966A	1" sweat unions 140°F Tset	11	255.00
280166A	1" NPT female unions 140°F Tset	11	272.00
280975A	1¼" sweat unions 130°F Tset	11	300.00
280175A	1¼" NPT female unions 130°F Tset	11	313.00
280976A	1¼" sweat unions 140°F Tset	11	300.00
280176A	1¼" NPT female unions 140°F Tset	11	313.00

BOILER PROTECTION RECIRCULATION AND DISTRIBUTION UNITS



281 ThermoBloc™

ThermoBloc™ boiler protection recirculation and distribution unit. Suitable fluids: water, up to 50% glycol solutions. Max. working pressure: 150 psi. Working temperature range: 40–210°F. Maximum pumping capacity: 10 gpm. Temperature gauge scale: 30–250°F. Thermostatic sensor: 130°F & 140°F Tset standard selections, see below. 115°F, 160°F Tset optional models*. Sensor cartridge accuracy: ±4°F. By-pass from boiler complete closing temperature: Tset +18°F (ex. 130°+18°=148°F). * Consult factory

Construction

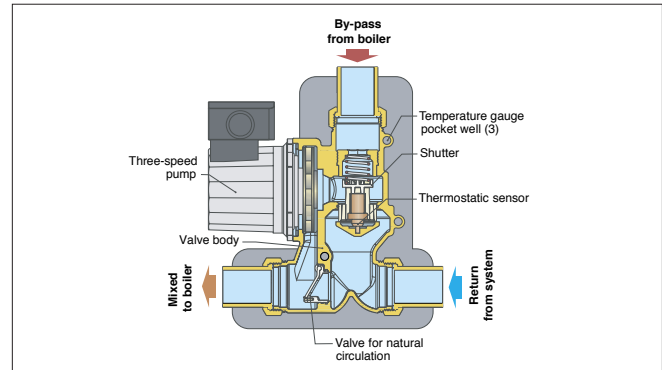

Code	Description	Lbs	USD
281965A	1" sweat unions 130°F Tset	11	783.00
281165A	1" NPT female unions 130°F Tset	11	838.00
281966A	1" sweat unions 140°F Tset	11	783.00
281166A	1" NPT female unions 140°F Tset	11	838.00
281975A	1¼" sweat unions 130°F Tset	11	922.00
281175A	1¼" NPT female unions 130°F Tset	11	964.00
281976A	1¼" sweat unions 140°F Tset	11	922.00
281176A	1¼" NPT female unions 140°F Tset	11	964.00
F19379	Replacement Pump	5	333.00

MEASURE DISPLAY AND TOTALIZE



CONTECA™ direct heat meter precisely measures and records instantaneous and totalized thermal energy usage for both heating and cooling. Included are two pulse inputs for a domestic hot and domestic water meters, and two universal pulse inputs for added metering for example gas or electric. All data can be accessed at the local user interface or remotely via Modbus, via a Datalogger which can handle up to 250 heat meters, or a Modbus-to-BACnet gateway for BAS systems. Available from .25 to 1000 GPM in an array of fittings, it complies with ASTM E3137/ E3137M – 17 Standard Specification for Heat Meter Instrumentation. **CALEFFI GUARANTEED.**



HEAT METERS

This diagram is for illustration purposes only

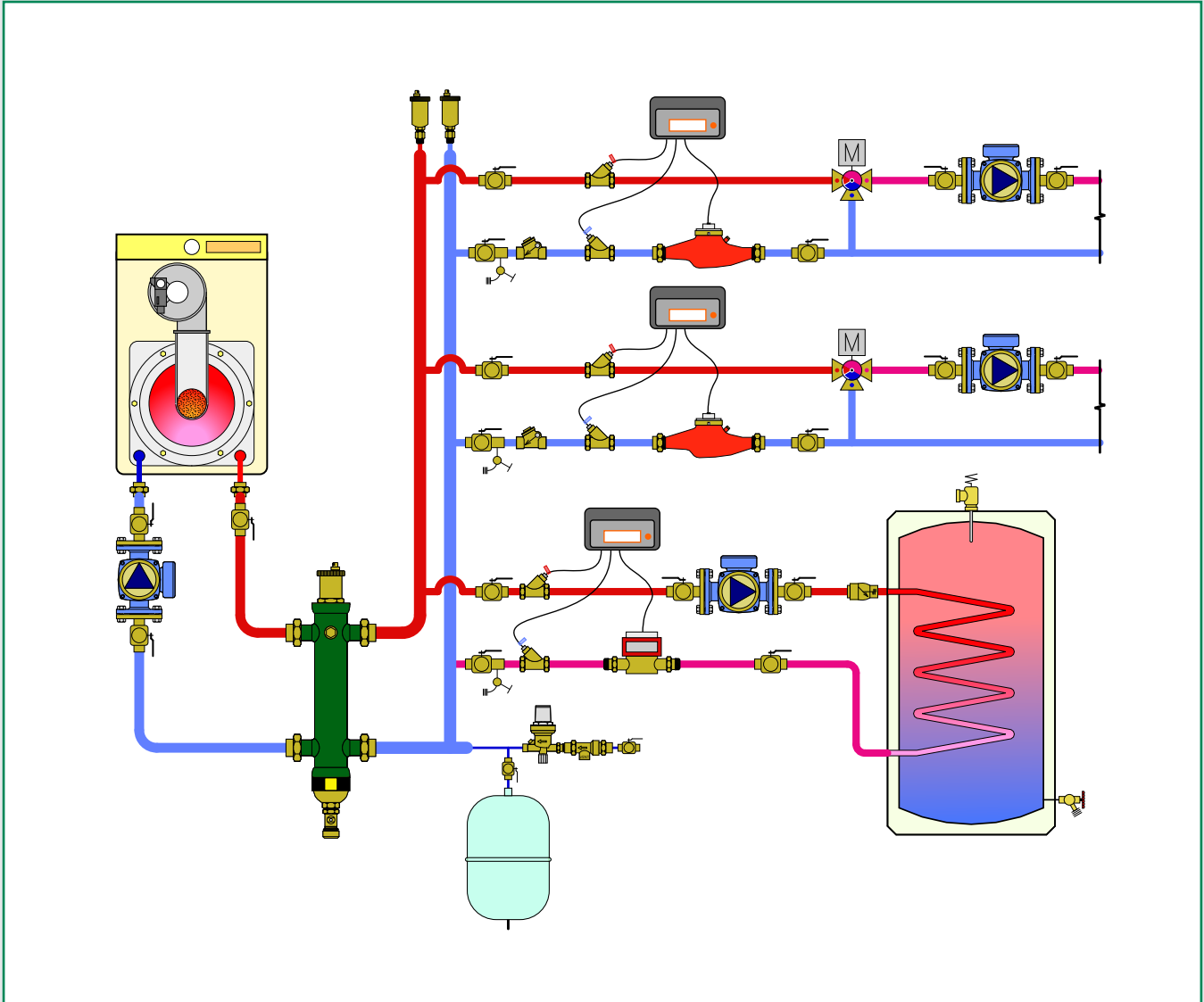

PRODUCTS INCLUDED IN SECTION

- Heat meters
- Heat meters accessories

HEAT METERS



Code	Description	Lbs	USD
750449A	Energy Meter, 0.25 to 10 GPM, ½" sweat	6.2	919.00
750440A	Energy Meter, 0.25 to 10 GPM, ½ MNPT	6.2	954.00
750446A	Energy Meter, 0.25 to 10 GPM, ½" press	6.2	1,001.00
750459A	Energy Meter, 0.25 to 10 GPM, ¾" sweat	7.1	930.00
750450A	Energy Meter, 0.25 to 10 GPM, ¾" MNPT	7.1	966.00
750456A	Energy Meter, 0.25 to 10 GPM, ¾" press	7.1	1,012.00
750469A	Energy Meter, 0.25 to 10 GPM, 1" sweat	7.9	977.00
750460A	Energy Meter, 0.25 to 10 GPM, 1" MNPT	7.9	1,012.00
750466A	Energy Meter, 0.25 to 10 GPM, 1" press	7.9	1,059.00
750463A	Energy Meter, 0.3 to 15 GPM, 1" FNPT	11.5	1,362.00
750473A	Energy Meter, 0.5 to 25 GPM, 1¼" FNPT	12.1	1,455.00
750483A	Energy Meter, 1 to 45 GPM, 1½" FNPT	18.7	1,687.00
750410A	Energy Meter 11 - 110 GPM, 2½" flanges	27	2,568.00
750411A	Energy Meter 14 - 140 GPM, 3" flanges	29	3,240.00
750412A	Energy Meter 22 - 220 GPM, 4" flanges	44	4,253.00
750413A	Energy Meter 35 - 350 GPM, 5" flanges	51	4,855.00
750414A	Energy Meter 88 - 880 GPM, 6" flanges	88	5,779.00
750415A	Energy Meter 100 - 1000 GPM, 8" flanges	110	6,473.00

Standard installation

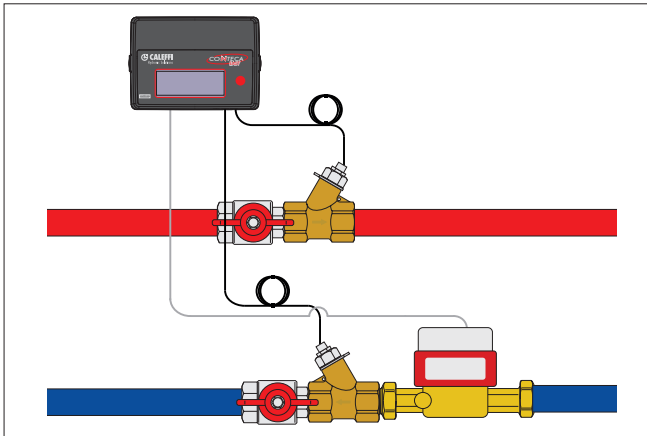

7504
CONTECA™ Energy meter

CONTECA™ is a direct heat meter designed to measure instantaneous and recorded history of thermal energy usage in residential and commercial buildings.

Micro processor:

Power supply: 24 VAC, 50/60 Hz, 1W.

Data transmission: 2-wire RS-485; selectable Modbus or M-bus (for use with Datalogger).

Ambient temperature: 40 – 113°F (4 – 45°C).

Environmental rating: NEMA 3S (IP 54).

Pulse inputs: Class 1B per EN 1434-2.

Temperature sensors:

Cable length: 26¼ feet (8 m).

Sensor type: 100 kohm NTC matched.

Temperature sensitivity: < 0.1°F.

Flow meters:

Body material: Brass.

Body threads: ISO 228 male straight.

Piping connections: Dual unions, tailpieces NPT, sweat, flanged, press.

Max. working pressure: 150 psi (10 bar)



Function

The CONTECA™ meter features an 8-digit liquid crystal display that enables easy reading of BTU consumed as well as a range of technical data indicating equipment operating status and data logging.

Each CONTECA™ includes an electronic calculator/user interface, two temperature sensors, fittings included. The flow meter comes with the CONTECA™ meter kit. In addition to the two temperature inputs and flow meter input, 4 additional pulse inputs, for optional equipment monitoring and data logging. The CONTECA™ is easy to install and commission, and complies with ASTM E3137 specification for heat metering instrumentation and European directive 2014/32/UE EN 1434 (MI 004).

The meter has integral RS-485 Modbus protocol 2-wire communication (default) for remote access and configuration when BAS is MODBUS-RT. The RS-485 protocol must be changed to M-bus when using the Datalogger. Up to 250 CONTECA meters can connect to one CONTECA® data logger.

Lead seals (included with each kit) to prevent tampering

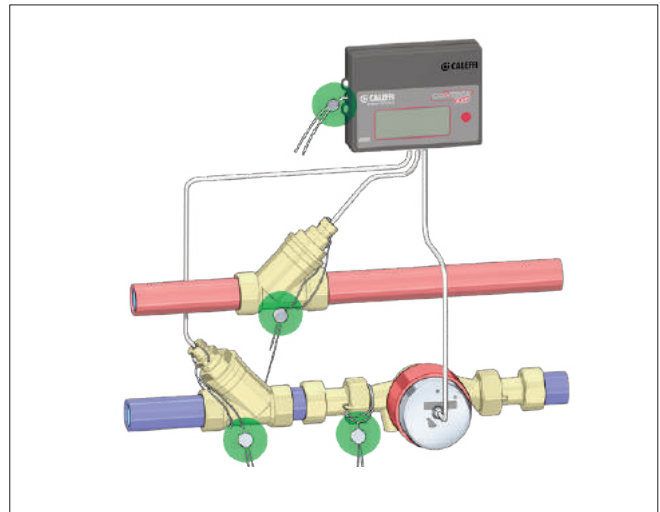

HEAT METERS

7504 CONTECA™ Datalogger



Power supply: 24 V (DC) ±10%, 24 V (AC) - 3 W.
 2 Ethernet ports: ETH1 (PoE), ETH2.
 Ambient temperature range: 32–122°F.
 Mounting: on a 35 mm DIN rail (EN 60715).
 Network addresses: up to 250 Conteca heat meters.
 Daily data logging: 10 years.
 Reports: In XLS or CSV format.



Code	Description	Lbs	USD
750450	Conteca Datalogger	2.0	2,047.00



MODBUS-RT-to-BACnet gateway.
 Converts CONTECA™ controller MODBUS-RT (RS-485 serial) output communication to BACnet IP or MSTP communication.
 Network capacity: up to 1500 registers (approx. 50 CONTECA heat meters).

Code	Description	Lbs	USD
755052	MODBUS-RT-to-BACnet gateway	1.0	1,687.00



Wall transformer.
 Input voltage: 120 V AC.
 Output voltage: 24 V AC.
 Power output: 20 VA.
 Agency approval: cULus.

Code	Description	Lbs	USD
NA10759	24 V AC wall transformer, 20 VA	1	32.50



V40 Replacement

Replacement flow meter (body only)
 Single jet rotary pulse flow meter measures liquid flow for energy heat metering production or consumption. Accurate to International Standards OIML R75, EN1434 and MID.
 Brass body.
 Sweat connections included.
 Working temperature range: -40—210°F.
 Max. fluid temperature: 265°F.
 Max. working pressure: 235 psi.
 Maximum glycol: 50%.

Code	Description	Lbs	USD
R79701	0.25 to 10 GPM	3.0	402.00



V40 Replacement

Replacement flow meter (body only)
 Multi-jet rotary pulse flow meter measures liquid flow for energy heat metering production or consumption. Accurate to International Standards OIML R75, EN1434 and MID.
 Brass body.
 Sweat connections included.
 Working temperature range: -40—210°F.
 Max. fluid temperature: 265°F.
 Max. working pressure: 235 psi.
 Maximum glycol: 50%.

Code	Description	Lbs	USD
R79702	0.3 to 15 GPM	5.0	716.00
R79703	0.5 to 25 GPM	8.0	847.00
R79704	1 to 45 GPM	14	1,006.00

Application Diagram

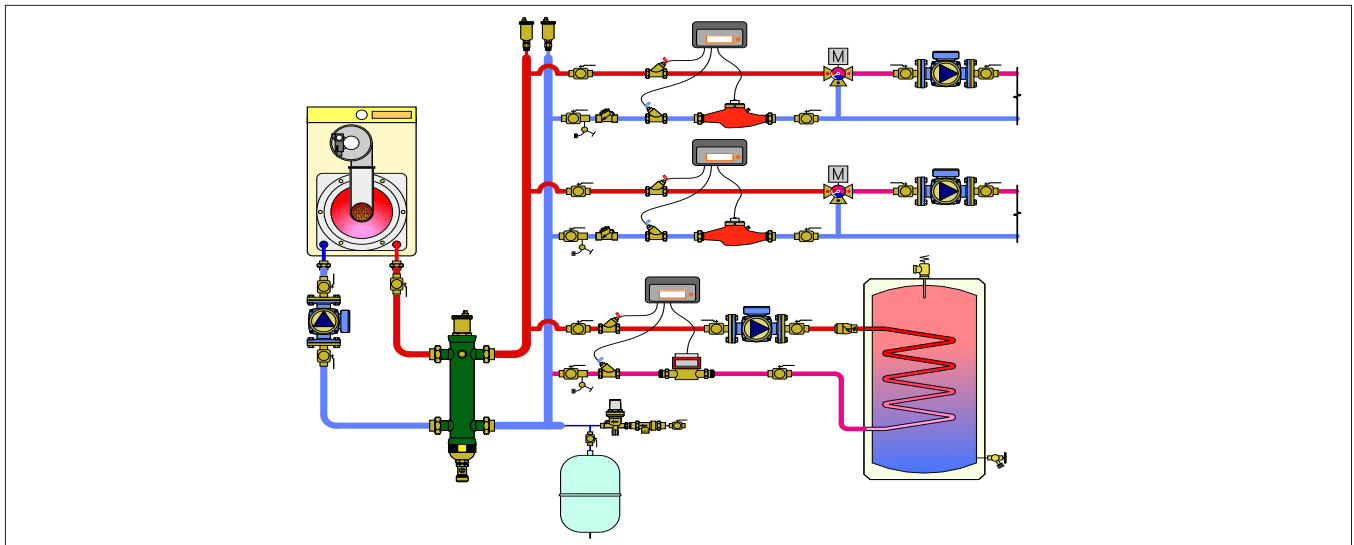

CALEFFI BIM LIBRARY THE HEART OF YOUR DESIGNS



Caleffi is BIM ready and we are eager to share our design know-how. The whole library is natively modeled in REVIT so files are of the highest quality, delivered in a user-friendly file size. Each family contains the parametric variants to allow calculation functions within AUTODESK® REVIT®. Choose Caleffi as part of your standard of excellence in design. **CALEFFI GUARANTEED.**

Download the free library

<http://bit.ly/nacaleffibim>

For more information

woody.dickinson@caleffi.com

INNOVATIVE HYDRONIC AND PLUMBING COMPONENTS

 **CALEFFI**
Hydronic Solutions



Caleffi Hydronic Solutions, a leader in state-of-the-art engineered solutions, manufactures and supplies high-quality components for hydronic heating and cooling, plumbing, heat metering and renewable energy systems for domestic, commercial and industrial buildings. Caleffi, an Italian based company, is a name recognized around the world for innovative solutions and superior performing products that help customers live comfortably and economically, while softening their impact on the environment. **CALEFFI GUARANTEED.**

Code	USD	Page(s)	Code	USD	Page(s)	Code	USD	Page(s)	Code	USD	Page(s)
100001A	13.50	75	120361A 000	226.00	75	132452AFC	212.00	66	1725E1AHE IN	1,418.00	44
110050A	25.30	108	120369A 000	214.00	75	132453AFC	243.00	66	1725F1A	1,274.00	44
110060A	27.70	108	120371A 000	255.00	75	132454AFC	212.00	66	1725F1A IN	1,274.00	44
1107B5LA	777.00	108	120379A 000	244.00	75	132455AFC	243.00	66	1725F1AHE	1,486.00	44
1107B5RA	777.00	108	121141A	119.00	74	132458AFC	243.00	66	1725F1AHE IN	1,486.00	44
1107C5LA	858.00	108	121149A	114.00	74	132459AFC	212.00	66	1725G1A	1,343.00	44
1107C5RA	858.00	108	121151A	120.00	74	132532AFC	221.00	66	1725G1A IN	1,343.00	44
1107D5LA	945.00	108	121159A	115.00	74	132533AFC	252.00	66	1725G1AHE	1,556.00	44
1107D5RA	945.00	108	121161A	246.00	74	132534AFC	221.00	66	1725G1AHE IN	1,556.00	44
1107E5LA	1024.00	108	121169A	235.00	74	132535AFC	252.00	66	1725H1A	1,412.00	44
1107E5RA	1024.00	108	121171A	276.00	74	132536AFC	235.00	66	1725H1A IN	1,412.00	44
1107F5LA	1105.00	108	121179A	263.00	74	132537AFC	266.00	66	1725H1AHE	1,624.00	44
1107F5RA	1105.00	108	121341A	129.00	74	132538AFC	252.00	66	1725H1AHE IN	1,624.00	44
1107G5LA	1204.00	108	121349A	122.00	74	132539AFC	221.00	66	1725I1A	1,480.00	44
1107G5RA	1204.00	108	121351A	131.00	74	132552A	181.00	67,108	1725I1A IN	1,480.00	44
1107H5LA	1283.00	108	121359A	123.00	74	132552AFC	221.00	66	1725I1AHE	1,693.00	44
1107H5RA	1283.00	108	121361A	255.00	74	132553AFC	252.00	66	1725I1AHE IN	1,693.00	44
112001	33.50	66	121369A	244.00	74	132554AFC	221.00	66	1725L1A	1,549.00	44
116000	54.50	71	121371A	285.00	74	132555AFC	252.00	66	1725L1A IN	1,549.00	44
116010	12.00	71	121379A	271.00	74	132556A	204.00	67	1725L1AHE	1,763.00	44
116140A	180.00	70	127140AFC	129.00	68	132556AFC	235.00	66	1725L1AHE IN	1,763.00	44
116140AC	215.00	70	127141AFC	96.10	68	132557AFC	266.00	66	1725M1A	1,617.00	44
116141A	192.00	70	127142AFC	95.00	68	132558AFC	252.00	66	1725M1A IN	1,617.00	44
116141AC	227.00	70	127143AFC	125.00	68	132559AFC	221.00	66	1725M1AHE	1,831.00	44
116150A	193.00	70	127144AFC	95.00	68	132637	168.00	66	1725M1AHE IN	1,831.00	44
116150AC	235.00	70	127145AFC	125.00	68	132657	177.00	66	1725N1A	1,687.00	44
116151A	205.00	70	127148AFC	125.00	68	132632AFC	255.00	66	1725N1A IN	1,687.00	44
116151AC	247.00	70	127149AFC	95.00	68	132633AFC	286.00	66	1725N1AHE	1,900.00	44
116160A	274.00	70	127150AFC	154.00	68	132634AFC	255.00	66	1725N1AHE IN	1,900.00	44
116160AC	381.00	70	127151AFC	102.00	68	132635AFC	286.00	66	1725O1A	1,755.00	44
116161A	287.00	70	127152AFC	103.00	68	132636AFC	270.00	66	1725O1A IN	1,755.00	44
116161AC	394.00	70	127153AFC	136.00	68	132637AFC	300.00	66	1725O1AHE	1,969.00	44
116170A	295.00	70	127154AFC	103.00	68	132638AFC	273.00	66	1725O1AHE IN	1,969.00	44
116170AC	412.00	70	127155AFC	136.00	68	132639AFC	244.00	66	200000	48.10	30
116171A	307.00	70	127156AFC	118.00	68	132652AFC	270.00	66	201000	86.00	30
116171AC	424.00	70	127157AFC	150.00	68	132653AFC	286.00	66	203502	163.00	30
116240A	234.00	70	127158AFC	136.00	68	132654AFC	255.00	66	220400A	47.20	31
116240AC	269.00	70	127159AFC	103.00	68	132655AFC	286.00	66	220500A	51.70	31
116250A	247.00	70	127160AFC	160.00	68	132656AFC	255.00	66	221400A	47.20	31
116250AC	289.00	70	127161AFC	129.00	68	132657AFC	300.00	66	221500A	51.70	31
116260A	329.00	70	127162AFC	128.00	68	132658AFC	273.00	66	250041A	53.20	107
116260AC	434.00	70	127163AFC	158.00	68	132659AFC	244.00	66	251003A	150.00	106
116270A	350.00	70	127164AFC	128.00	68	132662A	211.00	67,108	251004A	113.00	107
116270AC	467.00	70	127165AFC	158.00	68	132666A	238.00	67	252149A	163.00	106
116340A	246.00	70	127166AFC	135.00	68	132772A	281.00	67,108	252158A	211.00	106
116340AC	283.00	70	127167AFC	166.00	68	132776A	316.00	67	252159A	171.00	106
116350A	259.00	70	127168AFC	158.00	68	132882A	333.00	67,108	252168A	240.00	106
116350AC	301.00	70	127169AFC	128.00	68	132886A	375.00	67	252169A	199.00	106
116360A	341.00	70	127341AF	91.60	68	132992A	407.00	67,108	253040	50.50	106
116360AC	448.00	70	127342AF	86.60	68	132996A	459.00	67	253042	50.50	106
116370A	361.00	70	127344AF	86.60	68	142241A	93.30	73	253043	50.50	106
116370AC	478.00	70	127346AF	101.00	68	142251A	99.50	73	253044	50.50	106
116440A	163.00	71	127349AF	86.60	68	142261A	135.00	73	253046	50.50	106
116440AC	198.00	71	127351AF	95.60	68	142271A	193.00	73	253048	50.50	106
116441A	173.00	71	127352AF	91.10	68	142281A	216.00	73	278011	41.20	104
116441AC	210.00	71	127354AF	91.10	68	142291A	276.00	73	278751	569.00	104
116450A	175.00	71	127356AF	111.00	68	165001	51.10	48	278751A	738.00	104
116450AC	216.00	71	127359AF	91.10	68	165600A	916.00	48	278951A	788.00	105
116451A	186.00	71	127361AF	109.00	68	165602A	1,118.00	48	279051	677.00	104
116451AC	228.00	71	127362AF	105.00	68	165610A	916.00	48	279051A	847.00	104
116640A	234.00	70	127364AF	105.00	68	165612A	1,118.00	48	280165A	272.00	109
116640AC	269.00	70	127366AF	137.00	68	166600A	1,118.00	48	280166A	272.00	109
116650A	247.00	70	127369AF	105.00	68	166602A	1,322.00	48	280175A	313.00	109
116650AC	289.00	70	130400A	119.00	72	166610A	1,118.00	48	280176A	313.00	109
116660A	329.00	70	130500A	130.00	72	166612A	1,322.00	48	280965A	255.00	109
116660AC	434.00	70	130600A	155.00	72	167600A	1,322.00	48	280966A	255.00	109
116670A	350.00	70	130700A	194.00	72	167602A	1,525.00	48	280975A	300.00	109
116670AC	467.00	70	130800A	242.00	72	167610A	1,322.00	48	280976A	300.00	109
120141A 000	108.00	75	130900A	322.00	72	167612A	1,525.00	48	281165A	838.00	109
120149A 000	103.00	75	132060A	1,005.00	67	1725C1A	1,067.00	44	281166A	838.00	109
120151A 000	109.00	75	132080A	1,341.00	67	1725C1A IN	1,067.00	44	281175A	964.00	109
120159A 000	104.00	75	132100A	2,047.00	67	1725C1AHE	1,281.00	44	281176A	964.00	109
120161A 000	216.00	75	132432A	168.00	67	1725C1AHE IN	1,281.00	44	281965A	783.00	109
120169A 000	206.00	75	132432AFC	212.00	66	1725D1A	1,136.00	44	281966A	783.00	109
120171A 000	246.00	75	132433AFC	243.00	66	1725D1A IN	1,136.00	44	281975A	922.00	109
120179A 000	235.00	75	132434AFC	212.00	66	1725D1AHE	1,349.00	44	281976A	922.00	109
120341A 000	117.00	75	132435AFC	243.00	66	1725D1AHE IN	1,349.00	44	290030	35.00	66,69,100
120349A 000	112.00	75	132436A	190.00	67	1725E1A	1,205.00	44	301040	39.80	32
120351A 000	118.00	75	132438AFC	243.00	66	1725E1A IN	1,205.00	44	301140	39.80	32
120359A 000	113.00	75	132439AFC	212.00	66	1725E1AHE	1,418.00	44	301241	69.70	32

Code	USD	Page(s)	Code	USD	Page(s)	Code	USD	Page(s)	Code	USD	Page(s)
301341	69.70	32	520619A	275.00	56	523170A	1,099.00	57	535981HA	460.00	78
31401 FD	32.80	97	520619AC	298.00	56	523176A	1,119.00	57	535990HA	585.00	78
31403 FD	54.30	97	521101A	123.00	55	523177A	1,130.00	57	535991HA	596.00	78
31426 FD	64.70	97	521201A	100.00	58	523178A	1,051.00	57	536043A 103	168.00	80
31428 FD	84.40	97	521201AP	102.00	58	523179A	904.00	57	536043A 109	160.00	80
31553 FD	14.60	97	521301A	113.00	58	523180A	1,619.00	57	536053A 103	178.00	80
31554 FD	29.10	95,97	521333A	139.00	58	523186A	1,721.00	57	536053A 106	205.00	80
31901A	11.70	94,96	521342A	172.00	58	523188A	1,580.00	57	536053A 109	169.00	80
337221A	8.40	17	521347A	164.00	58	523190A	1,703.00	57	536063A 103	258.00	80
338452	49.70	31	521348A	164.00	58	523196A	1,913.00	57	536063A 106	297.00	80
339452	53.60	31	521349A	164.00	58	523198A	1,661.00	57	536063A 109	245.00	80
342452	32.70	31	521352A	179.00	58	523199A	1,293.00	57	536073A 103	464.00	80
343452	34.30	31	521357A	172.00	58	*533000H	1,009.00	49	536073A 106	534.00	80
386500	8.10	49	521358A	172.00	58	533340HA	88.20	79	536073A 109	441.00	80
387100	38.30	33,49	521359A	172.00	58	533341HA	99.70	79	536083A 103	700.00	80
387127	69.20	31	521362A	212.00	58	533350HA	94.80	79	536083A 106	805.00	80
39623	12.00	82	521367A	205.00	58	533351HA	106.00	79	536083A 109	665.00	80
41371A	47.30	95	521368A	205.00	58	533650HA	92.00	79	536093A 103	900.00	80
41372A	61.30	95	521369A	205.00	58	533651HA	103.00	79	536093A 106	1,035.00	80
41380A	504.00	18	521400A	167.00	54	533750HA	87.60	79	536093A 109	855.00	80
41787 CST	28.70	95,96	521400AC	184.00	54	533751HA	99.20	79	538202 FD	12.20	75,100
41788 CST	45.40	95	521406A	170.00	54	533850HA	87.60	79	538402 FD	12.50	13,24,75,100
41789 CST	59.10	95	521407A	160.00	54	533851HA	99.20	79	546016A	307.00	22
41882A	51.30	97	521407AC	177.00	54	533940HA	80.40	79	546050A	2,377.00	22
437516	6.90	33	521408A	160.00	54	533941HA	92.00	79	546060A	2,505.00	22
449000	8.10	51	521408AC	177.00	54	533950HA	87.60	79	546080A	3,226.00	22
449010	10.00	30	521409A	160.00	54	533951HA	99.20	79	546096A	293.00	22
449740	3.50	32	521409AC	177.00	54	535004	47.30	89	546097A	349.00	22
472000	164.00	30	521410A	197.00	54	535006HA	56.80	79	546100A	3,537.00	22
49684A	267.00	13,27	521410AC	213.00	54	535009HA	171.00	79	546108A	1,116.00	22
49685A	386.00	27	521416A	200.00	54	535051A	131.00	89	546109A	1,178.00	22
501502A	248.00	13,16	521417A	190.00	54	535056A	134.00	89	546116A	384.00	22
502015A	13.90	16	521417AC	206.00	54	535057A	129.00	89	546120A	5,103.00	22
502040A	13.90	16	521418A	190.00	54	535058A	129.00	89	546166A	393.00	22
502043 CST	106.00	84	521418AC	206.00	54	535059A	129.00	89	546167A	495.00	22
502043A	19.60	13,16	521419A	190.00	54	535061A	138.00	89	546168A	1,237.00	22
502113A	21.50	16	521419AC	206.00	54	535066A	145.00	89	546169A	1,380.00	22
502115A	18.70	16	521500A	175.00	54	535067A	139.00	89	546196A	367.00	22
502243A	33.60	16	521500AC	199.00	54	535068A	139.00	89	546197A	438.00	22
502343A	39.70	13,16	521506A	175.00	54	535069A	137.00	89	546198A	1,083.00	22
502630	17.30	17	521506AC	216.00	54	535340HA	110.00	78	546199A	1,135.00	22
502640	18.70	17	521507A	167.00	54	535341HA	121.00	78	546305A	195.00	24
502610A	12.40	17	521507AC	192.00	54	535350HA	118.00	78	546306A	209.00	24
502620A	13.00	17	521508A	167.00	54	535351HA	129.00	78	546306AM	230.00	25
502710A	17.20	17	521508AC	192.00	54	535360HA	154.00	78	546307A	305.00	24
502720A	18.20	17	521509A	167.00	54	535361HA	165.00	78	546307AM	335.00	25
508013A	192.00	84	521509AC	192.00	54	535370HA	329.00	78	546308A	398.00	24
508100A	5.90	17	521510A	205.00	54	535371HA	340.00	78	546308AM	438.00	25
519006	57.30	48	521510AC	228.00	54	535380HA	474.00	78	546309A	479.00	24
519502A	108.00	100	521516A	205.00	54	535381HA	485.00	78	546309AM	527.00	25
519566A	122.00	100	521516AC	246.00	54	535390HA	582.00	78	546328A	199.00	24
519599A	107.00	100	521517A	197.00	54	535391HA	593.00	78	546328AM	219.00	25
519600A	168.00	100	521517AC	221.00	54	535550HA	110.00	78	546335A	290.00	24
519609A	168.00	100	521518A	197.00	54	535551HA	120.00	78	546335AM	319.00	25
519700A	202.00	100	521518AC	221.00	54	535560HA	145.00	78	546341A	378.00	24
519709A	202.00	100	521519A	197.00	54	535561HA	156.00	78	546341AM	416.00	25
520051A	123.00	56	521519AC	221.00	54	535650HA	115.00	78	546354A	462.00	24
520051A	401.00	84	521600A	207.00	54	535651HA	126.00	78	546354AM	508.00	25
520061A	171.00	56	521600AC	231.00	54	535660HA	169.00	78	546366A	227.00	24
520410A	197.00	56	521606A	211.00	54	535661HA	180.00	78	546366AM	250.00	25
520410AC	213.00	56	521606AC	230.00	54	535670HA	469.00	78	546367A	348.00	24
520416A	200.00	56	521607A	199.00	54	535671HA	480.00	78	546367AM	383.00	25
520419A	190.00	56	521607AC	223.00	54	535680HA	673.00	78	546368A	454.00	24
520419AC	206.00	56	521608A	199.00	54	535681HA	687.00	78	546368AM	499.00	25
520500AX	230.00	63	521608AC	223.00	54	535690HA	829.00	78	546369A	554.00	24
520506AX	262.00	63	521609A	199.00	54	535691HA	840.00	78	546369AM	609.00	25
520509AX	222.00	63	521609AC	223.00	54	535750HA	110.00	78	546510A	1,788.00	21
520510A	205.00	56	521610A	238.00	54	535751HA	120.00	78	546510AM	2,495.00	26
520510AC	246.00	56	521610AC	261.00	54	535760HA	145.00	78	546550A	1,201.00	21
520510AX	262.00	63	521616A	242.00	54	535761HA	156.00	78	546550AM	1,550.00	26
520516A	197.00	56	521616AC	260.00	54	535940HA	101.00	78	546560A	1,277.00	21
520516AC	221.00	56	521617A	230.00	54	535941HA	112.00	78	546560AM	1,669.00	26
520516AX	295.00	63	521617AC	253.00	54	535950A	94.50	89	546580AM	2,256.00	26
520519A	205.00	56	521618A	230.00	54	535950HA	110.00	78	548006A	546.00	11
520519AC	228.00	56	521618AC	253.00	54	535951HA	120.00	78	548006US	410.00	11
520519AX	254.00	63	521619A	230.00	54	535960HA	145.00	78	548007A	655.00	11
520610A	283.00	56	521619AC	253.00	54	535961HA	156.00	78	548007US	463.00	11
520610AC	306.00	56	523160A	1,016.00	57	535970HA	321.00	78	548008A	859.00	11
520616A	287.00	56	523166A	1,070.00	57	535971HA	331.00	78	548008US	513.00	11
520616AC	310.00	56	523168A	1,006.00	57	535980HA	450.00	78	548009A	1,000.00	11

Code	USD	Page(s)	Code	USD	Page(s)	Code	USD	Page(s)	Code	USD	Page(s)
548009US	565.00	11	553549A	95.60	88	600086AS	10,608.00	62	6637M5A IN	929.00	47
548052A	2,406.00	11	553642A	113.00	88	600089A	2,884.00	60	6637N5A	993.00	47
548062A	2,563.00	11	553649A	108.00	88	600094A	2,999.00	60	6637N5A IN	993.00	47
548066A	585.00	11	559920A	770.00	12	600096A	3,194.00	60	6637O5A	1,056.00	47
548067A	745.00	11	559921A	793.00	12	600096AS	12,041.00	62	6637O5A IN	1,056.00	47
548068A	967.00	11	559922A	947.00	12	600099A	2,958.00	60	6637P5A	1,209.00	47
548069A	1,221.00	11	559931A	1,137.00	12	61215A	825.00	49	6637P5A IN	1,209.00	47
548082A	3,207.00	11	561402A	12.50	17	626009	19.70	100	6686C5S1A	493.00	46
548096A	518.00	11	561402A	35.00	90	626600A	210.00	100	6686C5S1A IN	493.00	46
548097A	625.00	11	562100	16.30	27	644004	154.00	41	6686D5S1A	564.00	46
548098A	817.00	11	573002A	171.00	88	644250A	262.00	41	6686D5S1A IN	564.00	46
548099A	955.00	11	573006A	191.00	88	644256A	262.00	41	6686E5S1A	635.00	46
548102A	3,589.00	11	573007A	182.00	88	644259A	257.00	41	6686E5S1A IN	635.00	46
549506A	793.00	10	573009A	164.00	88	644260A	284.00	41	6686F5S1A	708.00	46
549506US	650.00	10	573012A	185.00	88	644266A	286.00	41	6686F5S1A IN	708.00	46
549507A	962.00	10	573016A	206.00	88	644269A	278.00	41	6686G5S1A	778.00	46
549507US	758.00	10	573017A	196.00	88	644350A	283.00	41	6686G5S1A IN	778.00	46
549508A	1,258.00	10	573019A	177.00	88	644350A 3BY	283.00	41	6686H5S1A	851.00	46
549508US	894.00	10	573100A	57.30	81	644356A	298.00	41	6686H5S1A IN	851.00	46
549509A	1,428.00	10	573403A	78.10	81	644356A 3BY	298.00	41	6686I5S1A	922.00	46
549509US	1,084.00	10	573406A	95.00	81	644359A	290.00	41	6686I5S1A IN	922.00	46
549510A	5,439.00	10	573409A	74.20	81	644359A 3BY	290.00	41	6686L5S1A	993.00	46
549552A	3,641.00	10	573493A	76.40	81	644360A	329.00	41	6686L5S1A IN	993.00	46
549562A	3,881.00	10	573503A	82.00	81	644360A 3BY	329.00	41	6686M5S1A	1,065.00	46
549566A	834.00	10	574002A	397.00	88	644366A	334.00	41	6686M5S1A IN	1,065.00	46
549567A	1,057.00	10	574004A	302.00	82	644366A 3BY	334.00	41	6686N5S1A	1,136.00	46
549568A	1,373.00	10	574006A	378.00	82	644369A	321.00	41	6686N5S1A IN	1,136.00	46
549569A	1,604.00	10	574012A	409.00	88	644369A 3BY	321.00	41	6686O5S1A	1,209.00	46
549582A	4,856.00	10	574050A	363.00	82	645114	378.00	61	6686O5S1A IN	1,209.00	46
549596A	763.00	10	574056A	394.00	82	656344	88.80	36,50	6687C5S1A	522.00	46
549597A	930.00	10	574064A	320.00	82	656354	105.00	36,50	6687C5S1A IN	522.00	46
549598A	1,214.00	10	574066A	420.00	82	656354R	115.00	50	6687D5S1A	594.00	46
549599A	1,393.00	10	574151A	485.00	89	656404	66.30	30,36,50	6687D5S1A IN	594.00	46
551003A	115.00	19	574156A	515.00	89	656414	83.70	30,36,50	6687E5S1A	666.00	46
551003AC	121.00	19	574157A	500.00	89	659044	260.00	49	6687E5S1A IN	666.00	46
551004A	80.40	17	574206A	415.00	88	659064	284.00	49	6687F5S1A	736.00	46
551005A	172.00	18	574207A	406.00	88	659084	334.00	49	6687F5S1A IN	736.00	46
551005AC	180.00	18	574216A	427.00	88	659104	384.00	49	6687G5S1A	808.00	46
551006A	186.00	18	574217A	418.00	88	659124	434.00	49	6687G5S1A IN	808.00	46
551006AC	193.00	18	574700A	689.00	83	6636C5A	403.00	47	6687H5S1A	880.00	46
551007A	271.00	18	574706A	784.00	83	6636C5A IN	403.00	47	6687H5S1A IN	880.00	46
551007AC	277.00	18	59469	48.30	82	6636D5A	466.00	47	6687I5S1A	952.00	46
551008A	353.00	18	59470	51.30	82	6636D5A IN	466.00	47	6687I5S1A IN	952.00	46
551008AC	360.00	18	59471	102.00	82	6636E5A	528.00	47	6687L5S1A	1,023.00	46
551009A	431.00	18	59472	36.20	82	6636E5A IN	528.00	47	6687L5S1A IN	1,023.00	46
551009AC	438.00	18	59474A	10.20	17	6636F5A	591.00	47	6687M5S1A	1,094.00	46
551022A	111.00	19	59756	117.00	27	6636F5A IN	591.00	47	6687M5S1A IN	1,094.00	46
551022AC	118.00	19	59804A	10.90	17	6636G5A	653.00	47	6687N5S1A	1,166.00	46
551028A	177.00	18	59817A	26.30	94	6636G5A IN	653.00	47	6687N5S1A IN	1,166.00	46
551028AC	184.00	18	59829	100.00	27	6636H5A	716.00	47	6687O5S1A	1,237.00	46
551035A	258.00	18	59834A	23.70	94	6636H5A IN	716.00	47	6687O5S1A IN	1,237.00	46
551035AC	265.00	18	59840A	23.80	94	6636I5A	778.00	47	669050	27.60	51
551041A	336.00	18	59893A	17.50	94	6636I5A IN	778.00	47	675900A	8.70	51
551041AC	344.00	18	59894A	38.30	94	6636L5A	842.00	47	676000A	22.60	36
551050A	1,872.00	20	59904A	15.10	94	6636L5A IN	842.00	47	676256A	164.00	36
551050AT	1,780.00	20	59905A	21.30	94	6636M5A	904.00	47	676258A	158.00	36
551054A	411.00	18	59906A	35.70	94	6636M5A IN	904.00	47	676259A	158.00	36
551054AC	417.00	18	59977	18.80	82	6636N5A	966.00	47	676266A	188.00	36
551060A	2,001.00	20	59978	33.60	82	6636N5A IN	966.00	47	676268A	181.00	36
551060AT	1,909.00	20	59979	21.70	82	6636O5A	1,029.00	47	676269A	181.00	36
551066A	212.00	18	59980	8.20	82	6636O5A IN	1,029.00	47	676500A	44.80	36
551066AC	217.00	18	600054A	2,281.00	60	6636P5A	1,240.00	47	676756A	184.00	36
551067A	326.00	18	600056A	2,379.00	60	6636P5A IN	1,240.00	47	676758A	178.00	36
551067AC	333.00	18	600059A	2,258.00	60	6637C5A	429.00	47	676759A	178.00	36
551068A	421.00	18	600060A	10,777.00	60	6637C5A IN	429.00	47	676766A	208.00	36
551068AC	428.00	18	600060AS	13,770.00	62	6637D5A	492.00	47	676768A	199.00	36
551069A	514.00	18	600064A	2,508.00	60	6637D5A IN	492.00	47	676769A	199.00	36
551069AC	521.00	18	600064A 001	2,395.00	60	6637E5A	554.00	47	680507	8.10	49
551080A	2,649.00	20	600066A	2,559.00	60	6637E5A IN	554.00	47	680503A	8.10	49
551100A	2,963.00	20	600066A 001	2,469.00	60	6637F5A	617.00	47	680504A	8.10	49
551120A	4,313.00	20	600066AS	7,376.00	62	6637F5A IN	617.00	47	680505A	8.10	49
551150A	5,557.00	20	600069A	2,499.00	60	6637G5A	679.00	47	680555A	8.10	49
551716	200.00	19	600069A 001	2,379.00	60	6637G5A IN	679.00	47	681524	8.50	33
551705A	219.00	19	600074A	2,586.00	60	6637H5A	743.00	47	681555	8.30	33
551706A	233.00	19	600076A	2,604.00	60	6637H5A IN	743.00	47	681503A	8.50	33
551765A	231.00	19	600076AS	8,382.00	62	6637I5A	804.00	47	682530A	8.30	49
551766A	258.00	19	600079A	2,541.00	60	6637I5A IN	804.00	47	682540A	8.30	33,49
551795A	216.00	19	600080A	11,408.00	60	6637L5A	867.00	47	682545A	8.90	49
551796A	230.00	19	600084A	2,919.00	60	6637L5A IN	867.00	47	682550A	15.70	49
553542A	101.00	88	600086A	3,015.00	60	6637M5A	929.00	47	68003A	32.40	51,55,57

Code	USD	Page(s)	Code	USD	Page(s)	Code	USD	Page(s)	Code	USD	Page(s)
69122 CST	10.40	51	F19153	235.00	45	NA10407	56.20	97	NA20643	16.70	92
694045	15.80	13	F19346	34.00	66,67,108	NA10408	79.30	97	NA20646	15.40	92
750450	2047.00	113	F19379	333.00	109	NA10409	130.00	97	NA20647	11.90	92
750410A	2568.00	112	F29571	21.80	108	NA10419	30.80	94	NA20647C	20.10	92
750411A	3240.00	112	F29633	25.80	108	NA10419C	36.00	94	NA20648	11.90	92
750412A	4253.00	112	F29634	25.80	108	NA10425	21.20	13	NA20648C	20.10	92
750413A	4855.00	112	F29635	25.80	108	NA10426	3.60	13	NA20649	11.90	92
750414A	5779.00	112	F29636	25.80	108	NA10438	2.20	79	NA20649C	20.10	92
750415A	6473.00	112	F31868	9.70	96,97	NA10461	227.00	57	NA20650	16.70	92
750440A	954.00	112	F36073	6.60	31	NA10467	42.30	71	NA20650C	28.80	92
750446A	1001.00	112	F39807	48.80	27	NA10469	36.30	71	NA20653	19.00	92
750449A	919.00	112	F41186	3.00	96,97,98	NA10476	131.00	57	NA20656	16.80	92
750450A	966.00	112	F41661A	96.70	24	NA10481	218.00	104	NA20656C	37.30	92
750456A	1012.00	112	F49644	16.30	96	NA10484	15.10	95	NA20657	14.40	92
750459A	930.00	112	F49645	18.40	96	NA10485	21.30	95	NA20657C	26.30	92
750460A	1012.00	112	F49646	24.50	96	NA10486	31.90	95	NA20658	14.40	92
750463A	1362.00	112	F49647	40.80	96	NA10496	22.40	96	NA20658C	26.30	92
750466A	1059.00	112	F49657	16.30	96	NA10497	30.60	96	NA20659	14.40	92
750469A	977.00	112	F52429	4.10	55	NA10498	3.20	51,55	NA20659C	26.30	92
750473A	1455.00	112	F59650	29.70	88	NA10512	101.00	59	NA20660	27.70	92
750483A	1687.00	112	F59917	16.30	27	NA10556	12.20	96	NA20660C	39.70	92
755052	1,687.00	61,113	F61008	3.70	95,96,98	NA10615	437.00	61	NA20666	29.00	92
861527A CST	15.40	108	F61008/C	3.70	95,96,98	NA10616	641.00	61	NA20666C	57.10	92
861634A CST	24.70	108	F67037	0.70	51	NA10634	15.10	95	NA20667	25.00	92
940451	15.20	33	F69184	16.30	51	NA10635	21.30	95	NA20667C	37.00	92
942550	10.00	49	F69293	14.20	39	NA10636	31.90	95	NA20668	25.00	92
CBN116140	29.00	71	F69294	14.20	39	NA10706	36.70	95	NA20668C	37.00	92
CBN116160	31.00	71	F69590	2,940.00	60	NA10707	67.30	95,96	NA20669	25.00	92
CBN116440	28.60	71	F69591	67.30	61	NA10708	95.90	95	NA20669C	37.00	92
CBN130400	26.20	72	F69600	75.50	61	NA10709	171.00	95,96	NA20763	26.70	92
CBN130500	28.40	72	F69804	75.50	61	NA10715	133.00	96	NA20766	32.10	92
CBN130600	34.10	72	F69807	53.00	61	NA10741	15.00	58	NA20767	25.50	92
CBN130700	42.60	72	F69888	6.80	94	NA10758	388.00	61	NA20768	25.00	92
CBN130800	53.10	72	NA10001	8.10	96,97	NA10759	32.50	113	NA20769	19.70	92
CBN130900	70.80	72	NA10002	6.80	94	NA10778	23.00	13	NA20860	33.20	93
CBN142241A	24.00	73	NA10003	9.30	94,96	NA10786	46.80	94	NA20863	29.90	93
CBN142251A	25.50	73	NA10005	6.90	37	NA10796	24.00	13	NA20866	49.50	93
CBN142261A	34.80	73	NA10006	8.70	37	NA10797	25.00	13	NA20869	30.20	93
CBN142271A	49.60	73	NA10007	14.40	37	NA10801	40.00	13	NA20870	58.40	93
CBN142281A	55.80	73	NA10009	36.70	95	NA10802	44.00	13	NA20873	48.50	92
CBN546002	74.20	22	NA10038	209.00	45	NA10803	60.00	13	NA20876	64.10	92,93
CBN546118	93.80	22	NA10056	52.20	55	NA10804	68.00	13	NA20879	43.70	92,93
CBN546119	107.00	22	NA10058	57.30	55	NA10805	26.00	13	NA20973	63.50	93
CBN546205	47.30	24	NA10060	315.00	41	NA10806	30.00	13	NA20976	87.10	93
CBN546207	50.80	24	NA10061	18.40	98	NA10807	37.00	13	NA20979	84.90	93
CBN546209	55.50	24	NA10062	113.00	52	NA10808	43.00	13	NA20983	73.60	92
CBN551005	47.30	18	NA10064	8.20	101	NA11304	13.30	79	NA20986	133.00	92
CBN551007	50.80	18	NA10087	17.70	99	NA11305	14.70	79	NA20989	61.30	92
CBN551009	55.50	18	NA10089	24.60	94	NA11306	15.70	79	NA21083	69.20	93
F0000349	504.00	13,27	NA10103	8.20	101	NA11307	16.90	79	NA21086	116.00	93
F0000435	118.00	13	NA10104	17.60	27	NA11308	18.40	79	NA21089	88.20	93
F0000492	6.80	95	NA10117	8.20	101	NA11309	53.00	79	NA21180	97.80	93
F0000493	73.40	96	NA10119	24.20	99	NA11338	52.00	85	NA21186	129.00	93
F0000494	55.10	96	NA10164	21.00	94	NA12162	974.00	48	NA21189	86.00	93
F0000495	87.70	96	NA10165	24.60	94	NA12169	349.00	104	NA21190	123.00	93
F0000496	75.50	96	NA10166	40.30	94	NA12171	271.00	105	NA21193	102.00	92
F0000520	9.30	95,96	NA10167	8.20	101	NA12172	17.60	98	NA21196	186.00	92,93
F0000521	19.90	95	NA10197	1.30	88	NA12173	1,185.00	48	NA21199	111.00	92,93
F0000580	42.30	71	NA10204	17.60	27,107	NA12249	23.90	75	NA21293	107.00	93
F0000698	5.10	95,98	NA10246	32.70	108	NA12259	28.60	75	NA21296	171.00	93
F0000718	13.70	95	NA10247	40.50	108	NA12269	50.00	75	NA21299	126.00	93
F0000926	33.90	66	NA10262	9.00	33,49	NA16002	424.00	45	NA223529	100.00	75
F0000940	93.30	66,67	NA10273	17.60	107	NA16060	59.60	48	NA25510	2,444.00	85
F0000941	93.30	66,67	NA10288	34.40	108	NA16069	52.60	48	NA26650	40.70	104
F0000942	93.30	67	NA10302	9.00	33,49	NA16160	60.20	48	NA26659	27.80	69
F0000943	97.80	67	NA10313	9.70	33,49	NA16169	53.10	48	NA26660	41.80	69
F0000944	97.80	67	NA10315	115.00	57	NA16264	14.10	94	NA26669	69.40	69
F0000945	97.80	67	NA10328	47.50	55	NA16265	15.50	94,96	NA26711	469.00	105
F0000946	103.00	67	NA10342	10.00	40	NA16265L	35.50	94	NA26750	81.50	104
F0000947	103.00	67	NA10343	60.20	40	NA16265LC	45.00	94	NA26759	139.00	105
F0000948	103.00	67	NA10358	29.90	55	NA16266	27.60	94	NA26760	157.00	104
F0000962	1,513.00	61	NA10363	13.00	88	NA16266L	53.00	94	NA26769	152.00	105
F0001007	6.80	95	NA10366	50.80	57,61	NA16266LC	55.10	94	NA29284	92.00	22
F0001008	9.30	95,96	NA10367	125.00	57,61	NA17256	775.00	45	NA39588	59.10	13
F0001009	19.90	95	NA10370	8.20	101	NA17256HE	988.00	45	NA39589	25.80	13
F0001179	16.30	27	NA10371	14.30	101	NA20540	13.80	92	NA39753	35.10	13,20,27
F0001270	6.00	58	NA10403	18.30	94	NA20543	16.70	92	NA502640A	40.20	81
F0001286	42.30	71	NA10404	27.70	94	NA20549	12.10	92	NA502740A	23.60	17
F0001470	61.50	27	NA10405	2.00	55	NA20640	14.50	92	NA503040	30.50	100
F0001516	42.30	71	NA10406	37.60	97	NA20640C	22.50	92	NA51059	48.00	101

Code	USD	Page(s)	Code	USD	Page(s)	Code	USD	Page(s)	Code	USD	Page(s)
NA51069	61.30	101	NA546300A	27,172.00	23	NA553379	546.00	89	Z200053	52.80	39
NA51200	44.90	101	NA546300AM	29,607.00	23	NA553379R	830.00	89	Z200411	41.10	39
NA51240	75.50	101	NA546350A	34,358.00	23	NA57092	50.20	84	Z200412	41.10	39
NA51243	85.70	101	NA546350AM	37,004.00	23	NA57093	80.90	84	Z200413	41.10	39
NA51246	91.80	101	NA546510A	2,917.00	21	NA57094	763.00	49	Z200431	37.60	39
NA51247	69.40	101	NA546510AM	3,314.00	26	NA570971	404.00	84	Z200432	37.60	39
NA51248	69.40	101	NA546512A	4,205.00	21	NA570974	807.00	84	Z200512	56.20	39
NA51249	63.20	101	NA546512AM	4,603.00	26	NA573022	334.00	84	Z200513	56.20	39
NA51250	79.60	101	NA546515A	5,395.00	21	NA573100	151.00	84	Z200515	56.20	39
NA51253	91.80	101	NA546515AM	5,792.00	26	NA573102	77.50	84	Z200517	56.20	39
NA51256	97.90	101	NA546520A	11,030.00	21	NA59600	125.00	13,21,27	Z200532	49.70	39
NA51257	75.50	101	NA546520AM	12,588.00	26	NA61241	7.00	37	Z200535	49.70	39
NA51258	75.50	101	NA546525A	17,004.00	21	NA644200	228.00	41	Z200537	49.70	39
NA51259	69.40	101	NA546525AM	18,562.00	26	NA644300	247.00	41	Z200617	88.80	39
NA51300	57.10	101	NA546530A	21,060.00	21	NA644300 3BY	247.00	41	Z200635	84.40	39
NA51360	104.00	101	NA546530AM	22,617.00	26	NA669150	27.60	51	Z200637	84.40	39
NA51361	105.00	71	NA546535A	26,477.00	21	NA669250	27.60	51	Z200683	56.20	39
NA51363	110.00	101	NA546535AM	28,035.00	26	R0000892	7.00	37	Z200687	56.20	39
NA51366	143.00	101	NA546550A	1,925.00	21	R0000915	3.70	96	Z200737	112.00	39
NA51369	97.90	101	NA546550AM	2,199.00	26	R0001454	2.00	96,99	Z207411	56.20	39
NA51370	114.00	101	NA546560A	2,047.00	21	R0001457	2.90	95,96	Z207433	52.80	39
NA51371	115.00	71	NA546560AM	2,322.00	26	R0001458	1.20	96,97	Z207533*	64.70	39
NA51373	120.00	101	NA546580A	2,665.00	21	R0001459	5.80	96	Z207537*	64.70	39
NA51376	167.00	101	NA546580AM	3,062.00	26	R0001460	13.60	95,96	Z300053	65.80	39
NA51379	110.00	101	NA548052A	3,165.00	11	R0001461	3.70	96	Z300411	54.80	39
NA51400	149.00	101	NA548062A	3,404.00	11	R0001462	1.30	95	Z300412	54.80	39
NA51480	292.00	101	NA548082A	4,119.00	11	R11059	1.20	96,97	Z300413	54.80	39
NA51486	361.00	101	NA548102A	4,355.00	11	R11221	12.20	95	Z300431	51.40	39
NA51489	275.00	101	NA548120A	6,084.00	11	R11222	6.10	96	Z300432	51.40	39
NA51490	310.00	101	NA548150A	7,382.00	11	R19101	18.40	61	Z300512	68.50	39
NA51493	322.00	101	NA548200A	11,455.00	11	R20011	1.30	13,94,96	Z300513	68.50	39
NA51496	396.00	101	NA548250A	16,170.00	11	R29326	1,035.00	49	Z300515	68.50	39
NA51499	292.00	101	NA548300A	19,571.00	11	R31495	6.10	96	Z300517	68.50	39
NA52367HL	2,592.00	59	NA548350A	31,212.00	11	R31495	6.10	96	Z300532	63.50	39
NA533449HA	68.40	79	NA549052A	4,115.00	11	R31589	12.50	95,96,97	Z300533	63.50	39
NA533459HA	72.40	79	NA549052AM	4,239.00	10	R31706	553.00	48	Z300535	63.50	39
NA535840HA	77.00	78	NA549062A	4,426.00	11	R31981	9.30	94	Z300617	103.00	39
NA535841HA	87.00	78	NA549062AM	4,551.00	10	R39204	2.80	55	Z300635	95.60	39
NA535850HA	81.00	78	NA549082A	5,353.00	11	R39591	21.20	51,55,57	Z300637	95.60	39
NA535851HA	91.00	78	NA549082AM	5,633.00	10	R41441	31.70	97	Z300687	71.40	39
NA535860HA	107.00	78	NA549102A	5,660.00	11	R41660	42.00	95	Z300737	116.00	39
NA535861HA	117.00	78	NA549102AM	5,940.00	10	R50005	2.90	97	Z307433*	66.30	39
NA535870HA	234.00	78	NA549120A	7,905.00	11	R50008	5.80	97	Z307537*	78.60	39
NA535871HA	244.00	78	NA549120AM	8,184.00	10	R50047	11.60	97	Z40	135.00	37
NA535880HA	330.00	78	NA549150A	9,591.00	11	R50048	14.10	97	Z40F	152.00	37
NA535881HA	340.00	78	NA549150AM	9,872.00	10	R51838	30.50	95,96	Z42	147.00	37
NA535890HA	383.00	78	NA549200A	15,497.00	11	R53003	24.90	96,97	Z44	131.00	37
NA535891HA	393.00	78	NA549200AM	17,086.00	10	R53004	24.90	97	Z44P	181.00	37
NA545305	171.00	25	NA549250A	21,560.00	11	R53005	28.50	97	Z45	143.00	37
NA545306	198.00	25	NA549250AM	23,149.00	10	R56142	1.60	27	Z45P	184.00	37
NA545355	206.00	25	NA549300A	28,875.00	11	R56214	1.70	27,51	Z45PL	202.00	37
NA545356	240.00	25	NA549300AM	30,464.00	10	R59119	30.50	95,96	Z46	178.00	37
NA545365	186.00	25	NA549350A	34,326.00	11	R59681	15.50	27	Z46P	208.00	37
NA545366	223.00	25	NA549350AM	35,915.00	10	R69176	16.00	51	Z47	207.00	37
NA545376	328.00	25	NA551050A	2,243.00	20	R69413	6.10	51	Z50	138.00	37
NA545395	170.00	25	NA551060A	2,398.00	20	R79701	402.00	113	Z50F	156.00	37
NA545396	189.00	25	NA551080A	3,174.00	20	R79702	716.00	113	Z54	135.00	37
NA546050T	2,276.00	23	NA551100A	3,552.00	20	R79703	847.00	113	Z54P	184.00	37
NA546050TM	2,631.00	23	NA551120A	5,167.00	20	R79704	1006.00	113	Z55	147.00	37
NA546060A	3,062.00	23	NA551150A	6,659.00	20	Z111000	93.10	38	Z55P	187.00	37
NA546060AM	3,440.00	23	NA551200A	10,897.00	20	Z111900	93.10	38	Z55PL	205.00	37
NA546080A	3,943.00	23	NA551250A	16,344.00	20	Z116000	93.10	38	Z55S	178.00	37
NA546080AM	4,476.00	23	NA551300A	21,248.00	20	Z121000	86.30	38	Z56	181.00	37
NA546100A	4,323.00	23	NA553362	480.00	89	Z126000	86.30	38	Z56P	212.00	37
NA546100AM	4,866.00	23	NA553362R	765.00	89	Z131000	102.00	38	Z57	210.00	37
NA546120A	6,236.00	23	NA553366	515.00	89	Z136000	102.00	38	ZSR101	104.00	40
NA546120AM	6,836.00	23	NA553366R	801.00	89	Z141000	94.80	38	ZSR103	245.00	40
NA546150A	7,608.00	23	NA553369	470.00	89	Z146000	94.80	38	ZSR104	287.00	40
NA546150AM	8,249.00	23	NA553369R	756.00	89	Z151000	96.50	38	ZSR106	351.00	40
NA546200A	14,132.00	23	NA553372	556.00	89	Z161000	88.60	38	ZVR103	186.00	40
NA546200AM	16,183.00	23	NA553372R	842.00	89	Z200041	41.10	39	ZVR104	221.00	40
NA546250A	21,729.00	23	NA553376	619.00	89	Z200042	41.10	39	ZVR106	287.00	40
NA546250AM	23,365.00	23	NA553376R	905.00	89	Z200043	41.10	39			

LIMITED WARRANTY

COVERAGE: Caleffi North America Inc. ("WARRANTOR") warrants that each Caleffi PRODUCT will be free from defects in material and workmanship for a period of two years* from the date of shipment/delivery of the PRODUCT (that can be identified by the "Caleffi" trademark, trade name, or logo affixed to them). The Limited Warranty is referred to herein as "the Limited warranty." The PURCHASER'S sole and exclusive remedy under this Limited Warranty for defects in the PRODUCT shall be the repair, replacement or refund of the purchase price, in WARRANTOR'S sole discretion, of the defective PRODUCT, or components thereof.

***PRODUCT warranty exceptions:**

Switching Zone Relays	3 years
Switching zone relays + valves (Z-one valves and Z-one relays installed together)	5 years
Storage Tank	6 years

NOT COVERED: This Limited Warranty also does not apply to, and WARRANTOR shall have no liability or responsibility in respect of, damages or expenses relating to:

- The failure to properly store, transport, install or use the PRODUCT as, for example, specified in any manuals or other literature supplied by WARRANTOR, on WARRANTOR'S website, or in accordance with any applicable laws, codes, regulators or standards;
- Any PRODUCT purchased from any entity other than WARRANTOR;
- Alteration, change or modification of the PRODUCT, including its subcomponents, parts or assemblies;
- WARRANTOR also makes no warranty that a PRODUCT manufactured does not infringe the intellectual property or other proprietary rights of any third party;
- Accidents, misuse, abuse, abnormal use, improper use, negligent use, wilful misconduct, or use exceeding the recommended and permitted limits of the PRODUCT, and/or normal wear or deterioration;
- Any defect or non-conformity that has not been timely and promptly communicated in writing to WARRANTOR as set forth herein.
- Any damage, cost or expense caused by Act of God; or
- Loss of time, loss of use, inconvenience, loss of profits, lost business, lost business opportunities, damage to reputation, goodwill and any incidental or consequential damages arising out of or relating to the PRODUCT, or other matters not specifically covered hereunder.

PROCEDURE: Upon delivery, PURCHASER shall, within one (3) business day, inspect the PRODUCT for conformity and visible defects. PURCHASER shall give WARRANTOR immediate written, specific and detailed notice of any non-conformities or defects regarding the PRODUCT. Upon receipt of the written notice of claim, WARRANTOR shall have the right to inspect the PRODUCT. In the event of a defect covered by this Limited Warranty, WARRANTOR will, at WARRANTOR'S discretion, repair or replace the PRODUCT or any component of the PRODUCT or refund the purchase price for that particular PRODUCT. In the event that PURCHASER submits a warranty claim that, in the sole reasonable discretion of the WARRANTOR, is unfounded, the PURCHASER shall reimburse the WARRANTOR all reasonable costs incurred by the WARRANTOR in evaluating the warranty claim (i.e. travel, lodging, expert evaluations, etc.). WARRANTOR must approve, in advance and in writing, all repairs or replacements covered under or performed pursuant to this Limited Warranty. Any warranty repairs or service must be performed exclusively by WARRANTOR or other authorized representative of WARRANTOR or by another servicing facility pre-approved in writing by WARRANTOR. Acceptance of any Limited Warranty claim is not an admission that any PRODUCT or any of its component parts are defective. The PURCHASER forfeits any rights it may have under this Limited Warranty if the PURCHASER does not follow the procedure described herein.

All requests and notices under this Limited Warranty shall be directed to:

Caleffi North America Inc.
3883 West Milwaukee Road
Milwaukee, WI 53208
E-Mail: returns.us@caleffi.com
Phone (414) 238-2360
Fax: (414) 238-2366

LIMITATION OF DAMAGES: Except as expressly provided by this Limited Warranty, **WARRANTOR SHALL NOT BE RESPONSIBLE FOR ANY INCIDENTAL OR CONSEQUENTIAL DAMAGES ASSOCIATED WITH THE USE OR NON-USE OF THE PRODUCT OR A CLAIM UNDER THIS LIMITED WARRANTY, WHETHER THE CLAIM IS BASED ON CONTRACT, TORT OR OTHERWISE.** The foregoing statements of warranty are exclusive and in lieu of all other remedies or damages. Some states do not allow the exclusion or limitation of incidental or consequential damages, so only in this case this limitation or exclusion may not apply to you.

This Limited Warranty shall be the sole and exclusive remedy available to the PURCHASER with respect to this PRODUCT. In the event of any alleged breach of any warranty or any legal action brought by the PURCHASER, based on breach of warranty, alleged negligence or other tortious conduct by WARRANTOR, the PURCHASER'S sole and exclusive remedy will be the repair or replacement of any defective PRODUCT as stated herein. In no event shall the liability of the WARRANTOR exceed the purchase price of the PRODUCT.

DISCLAIMER: ANY IMPLIED WARRANTY OF MERCHANTABILITY OR FITNESS FOR A PARTICULAR PURPOSE AND ALL IMPLIED WARRANTIES ARISING FROM A COURSE OF DEALING, USAGE OF TRADE, BY STATUTE OR OTHERWISE, IS HEREBY STRICTLY LIMITED TO THE TERM OF THIS WRITTEN WARRANTY. This Limited Warranty shall be the sole and exclusive remedy available to the PURCHASER with respect to this PRODUCT. In the event of any alleged breach of any warranty or any legal action brought by the PURCHASER based on alleged negligence or other tortious conduct by WARRANTOR, the PURCHASER'S sole and exclusive remedy will be repair or replacement of defective materials or refund of the purchase price, as stated herein.

TRANSFER OF LIMITED WARRANTY: This warranty is made by WARRANTOR with only first PURCHASER of the PRODUCT and does not extend to any subsequent PURCHASER or any third parties. The unexpired portion of this Limited Warranty may not be transferred to any entity.

APPLICABLE LAW: The parties expressly acknowledge and irrevocably agree that any and all claims or disputes arising out of or otherwise relating to this Limited Warranty shall be decided by a binding arbitration administered by the American Arbitration Association pursuant to Commercial Industry Rules in effect as of the date of this Limited Warranty, to the exclusion of any courts of any place, except as necessary for the enforcement of arbitration rights. The place for any such arbitration shall be The State of Wisconsin. PURCHASER expressly waives any provision of law in the jurisdiction in which PURCHASER is located or any other potentially applicable law which conflicts with any provision of this Limited Warranty at any time.

OTHER RIGHTS: Your acceptance of delivery of The PRODUCT constitutes your acceptance of the terms of this Limited Warranty. This Limited Warranty gives you specific legal rights, and you may also have other rights which vary from state to state. If any term or provision of this Limited Warranty is invalid or unenforceable under any local, state, or federal law, statute, judicial decision, regulation, ordinance, executive order or other rule of law, such term shall be deemed reformed or deleted, but only to the extent necessary to comply with such statute, regulation, ordinance, order or rule and the remaining provisions of this Limited Warranty shall remain in full force and effect.

ENTIRE AGREEMENT: This document alone contains the entire Limited Warranty given by WARRANTOR in respect of the PRODUCT. Nothing in WARRANTOR'S product literature, marketing materials, advertisements and technical specifications expand or enlarge the scope of this Limited Warranty. There are no terms, promises, conditions or warranties regarding the PRODUCT other than those expressly contained herein. WARRANTOR specifically does not authorize any person, including but not limited to any dealer or other agent or employee of WARRANTOR, to extend the time, scope, terms or conditions of this Limited Warranty or to create or assume for WARRANTOR any other obligation or liability with respect to the PRODUCT or other products designed, manufactured or sold by WARRANTOR. All terms of this Limited Warranty are contractual and not mere recitals, and constitute material terms of this Limited Warranty. It is agreed and acknowledged that the provisions of this Limited Warranty allocate the risks between WARRANTOR and PURCHASER, that WARRANTOR'S pricing reflects this allocation of risk, and but for this allocation and limitation of liability, WARRANTOR would not have entered into this Limited Warranty. The agents, employees, and dealers of Caleffi Products are not authorized to make modifications to this limited warranty or make additional warranties binding on Caleffi.

THIS DOCUMENT AND ALL PROVISIONS CONTAINED HAS BEEN SPECIFICALLY AGREED BETWEEN THE PARTIES.



HAVE A QUESTION? WANT TO LEARN MORE?

We are committed to your success and are here to help. Check out our website CALEFFI.US an expansive collection of product information, training webinars, BIM objects, as well as our expansive library of educational idronics™ journals. **CALEFFI GUARANTEED.**

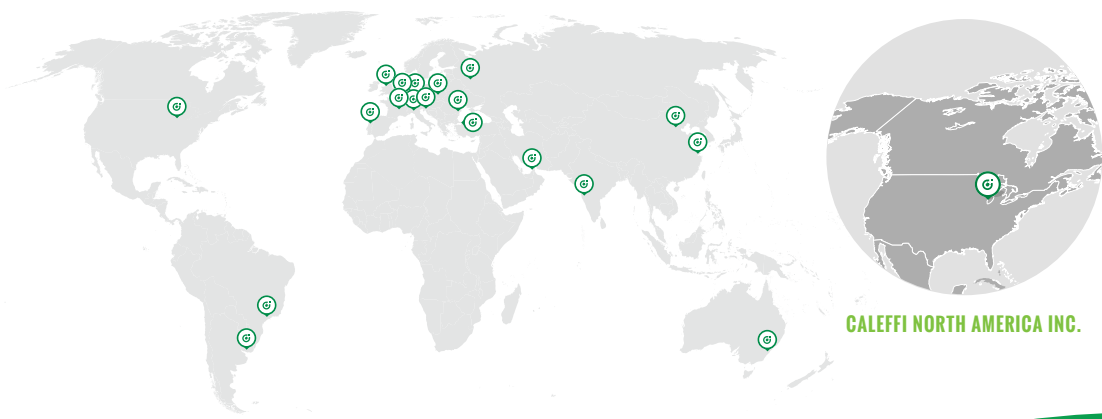

INQUIRES:

SALES:
sales@caleffi.com

TECHNICAL SUPPORT:
techsupport@caleffi.com

MARKETING/PR:
marketing.us@caleffi.com

**SEARCHING FOR A
REPRESENTATIVE**

www.caleffi.info/dealerlocator/





Suggested List Price
Effective February 1, 2021
Canceling All Prior Issues

specifications and prices are subject to change without notice

Caleffi North America, Inc..

3883 W. Milwaukee Road · Milwaukee, WI 53208

Tel: 414.238.2360 · Fax: 414.238.2366

sales@caleffi.com | www.caleffi.com

© 2021 Copyright Caleffi

SKU: 21-001

