

FlowCal™ Automatic flow balancing valve with polymer cartridge

121 series



01141/19 NA

Replaces 01141/11 NA



Function

The FlowCal™ automatic flow balancing valve maintains a constant fixed flow rate within varying system differential pressure ranges. Operation is fully automatic requiring no manual adjustment. The 121 series utilize an exclusive, interchangeable flow cartridge, made of anti-scale, low noise polymer for use in cooling and heating systems. The FlowCal 121 series automatic flow balancing valves are available with integral shut-off ball valve and optional factory-installed pressure and temperature test ports. Drain valves are also available as an accessory for installing in the blowdown port connection.

Product range

121 Series Automatic flow balancing valve with polymer cartridge, ball valve, with and without Pressure and Temperature Test ports _____ sizes 1/2" - 3/4" - 1" - 1 1/4"

Technical specifications

Valve body

- Materials:
- body: brass
 - FlowCal flow cartridge: anti-scale polymer
 - spring: stainless steel
 - seals: EPDM
 - ball: brass, chrome-plated
 - ball seat and stem seal: PTFE
 - lever: zinc coated steel with vinyl grip
 - pressure and temperature test port plugs: brass
 - pressure and temperature test ports: body and cap- brass; core- nordel
 - drain port plug: brass

Medium: water, glycol solutions
 Max. percentage of glycol: 50%
 Max. working pressure: 400 psi (400 WOG)
 Working temperature range: 32-212°F (0-100°C)

Connections: 1/2", 3/4", 1", 1 1/4" FNPT or Sweat with union x FNPT or Sweat

Pressure and temperature test ports connections: 1/4" FNPT
 Blowdown port connection: 1/2" - 3/4": 1/4" FNPT
 1" - 1 1/4": 1/2" FNPT

Flow rate: 27 flow rate settings ranging from 0.5 - 21 GPM
 Flow accuracy: ±10%
 Differential Pressure Control Ranges: 2-14, 2-32, 4-34, 5-35, 3-32, 4-35 (see table on page 5)

Identification: metal plate with ball chain stating ΔP range and fixed flow rate

Dimensions

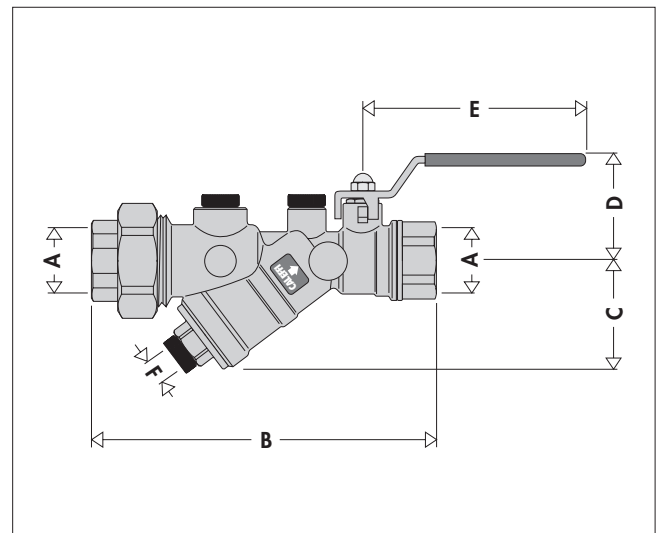

Code	A	B	C	D	E	F	Weight (lb)
121141 ..	1/2"	6 3/16"	1 15/16"	1 15/16"	3 15/16"	1/4"	2.7
121151 ..	3/4"	6 1/4"	1 15/16"	1 15/16"	3 15/16"	1/4"	2.7
121161 ..	1"	8 5/8"	3 3/4"	2 5/8"	4 3/4"	1/2"	5.0
121171 ..	1 1/4"	8 11/16"	3 3/4"	2 5/8"	4 3/4"	1/2"	5.0

Circuit balancing

Modern heating and air-conditioning systems have to guarantee a high level of thermal comfort with a low energy consumption. This means supplying the system terminals with the correct design flow rates, to produce balanced hydraulic circuits.

Unbalanced circuits

In case of an unbalanced circuit, the hydraulic imbalance between emitters creates areas with temperatures which are not uniform, and, as a consequence, problems with thermal comfort and higher energy consumption.

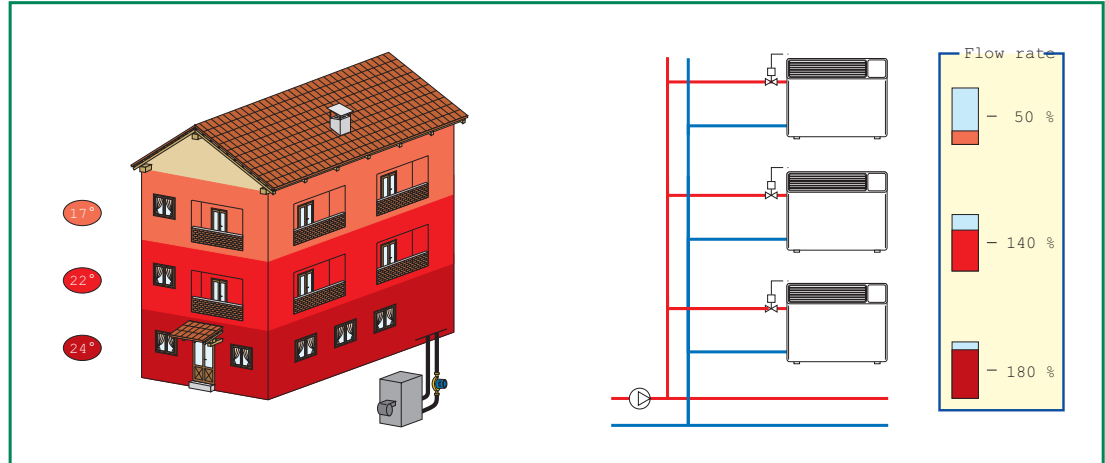

Circuits balanced with manual valves

Traditionally, hydraulic circuits are balanced using manual calibration valves. With these static-type devices, such circuits are difficult to balance perfectly and have operating limitations in case of partial closure by means of the control valves. The flow rate in the open circuits **does not remain constant at the nominal value.**

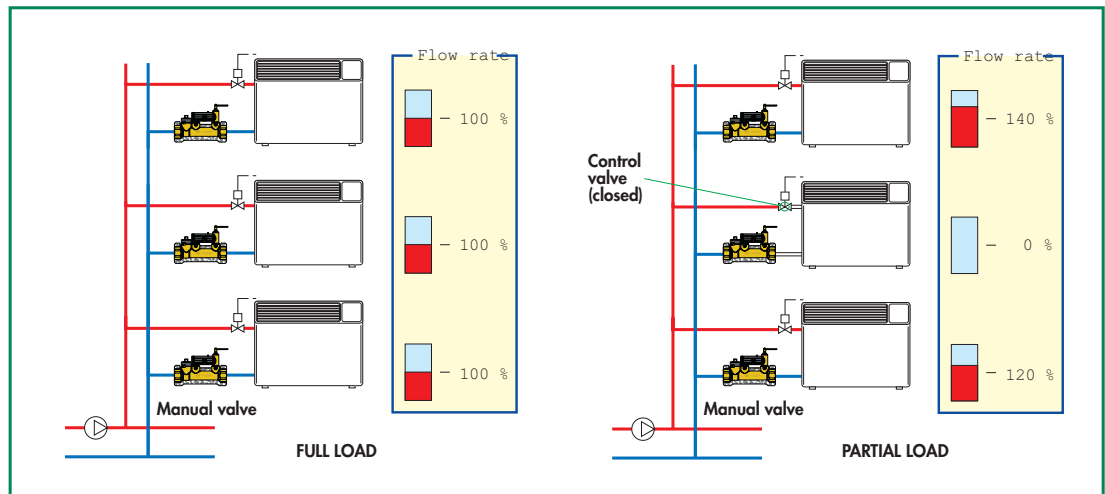

Circuits balanced with FlowCal

FlowCal balances the hydraulic circuit by automatically controlling the design flow rate to each emitter. Even with some circuits partially closed by the control valves, the flow rates in the open circuits **remain constant at the nominal value.** The system always provides the greatest comfort and the highest energy savings.

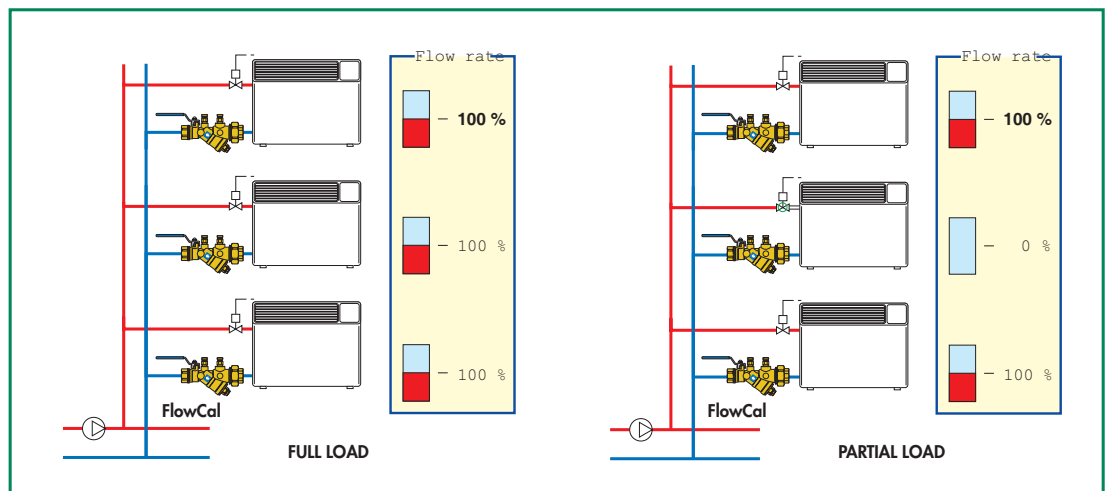

FlowCal™ Automatic Flow Balancing Valves

Function

The FlowCal automatic flow balancing valve guarantees a constant flow rate when the upstream/downstream pressure differential varies.

It is therefore necessary to refer to the Δp vs. flow rate diagram and to a basic diagram illustrating the operation methods and the relevant variable effects.

Operating principle

The FlowCal flow cartridge is composed of a cylinder, a spring-loaded piston, and a combination of fixed and variable geometric orifices through which the fluid flows. These variable orifice sizes increase or decrease by the piston movement, contingent on the system's fluid thrust. A specially calibrated spring counteracts this movement to regulate the amount of fluid which may pass through the valve orifices, maintaining a balanced system. FlowCal valves are high performance automatic flow balancing valves which control selected flow rates within a very tight tolerance (approximately 10%) and offer a wide range of operation.

Below the differential pressure control range (< 2 psid)*

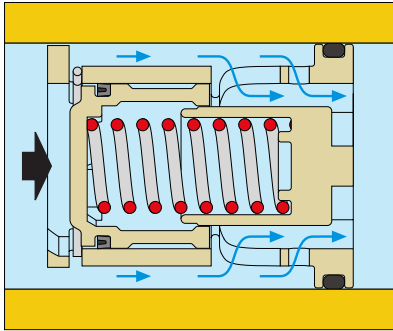

In this case, the spring-loaded regulating piston remains in equilibrium without compressing the spring and gives the fluid the maximum free flow area. When below the differential pressure control range the piston acts as a fixed orifice and thus the flow rate through the FlowCal depends only on the differential pressure.

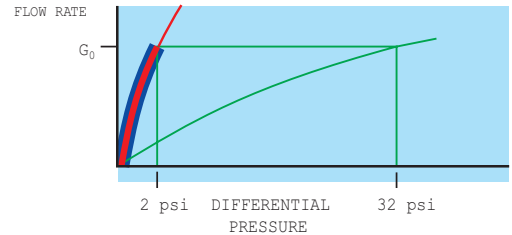
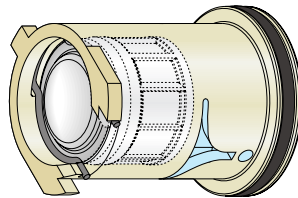

Range Δp 2-32 psi where G_0 = nominal flow

Within the differential pressure control range (2 - 32 psid)*

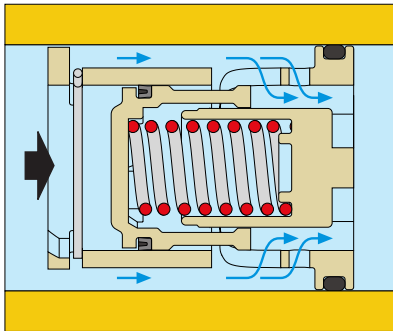

If the differential pressure is within the control range, the spring-loaded piston is positioned to give the fluid a free flow area permitting regular flow at the **nominal rate** for which the FlowCal is set up.

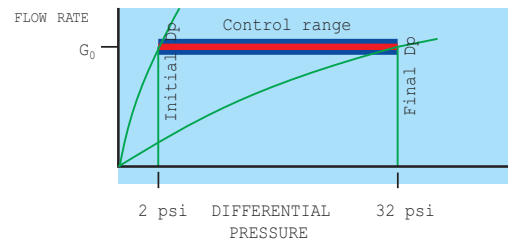
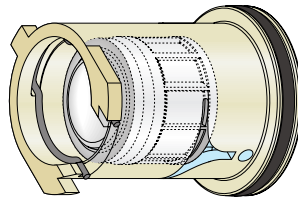

Above the differential pressure control range (> 32 psid)*

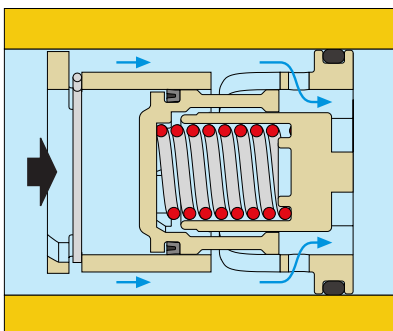

In this case, the spring-loaded piston fully compresses a spring and leaves only the fixed orifice for the fluid to pass through. The flow rate through the FlowCal depends only on the differential pressure.

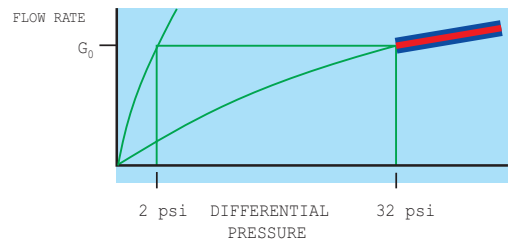
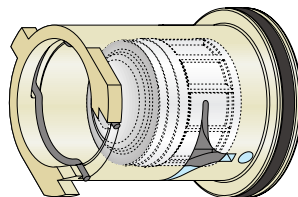

Range Δp 2-32 psi where G_0 = nominal flow

Construction details

Polymer flow cartridge

The flow rate cartridge is made of an anti-scale polymer, specially engineered for use in cooling, heating and domestic water systems, to prevent mineral buildup.

Its mechanical behavior is excellent in a wide range of working temperatures, it features high resistance to the abrasion caused by continuous fluid flow, it is insensitive to the deposit of scale and is fully compatible with glycols and additives used in circuits.

Exclusive design

With its exclusive design, the flow cartridge is able to accurately control the flow rate in a wide range of operating pressures. A special internal chamber acts as a damper for the vibrations triggered by the fluid flow, allowing low noise operating conditions to the device.

For these reasons it can be used in systems both on zone branch circuits and directly at the terminals.

Ball valve

The control stem of the ball valve has a blowout-proof stem and the reversible closing lever is covered with vinyl.

Replaceable cartridge

The internal flow cartridge can be removed easily from the valve body for inspection, cleaning or replacement by unscrewing the cap as shown. Tools are not needed as the cartridge is removed with an integral retaining wire and ring.

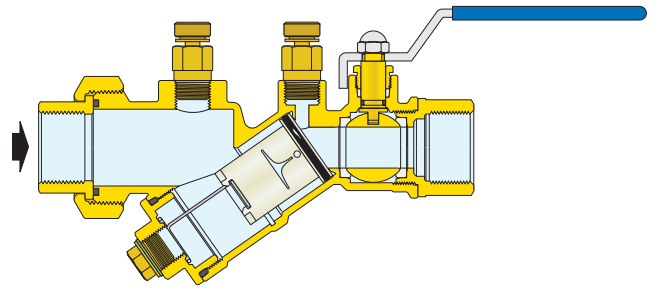
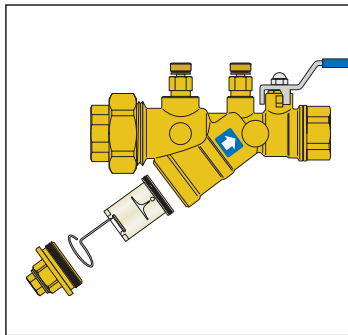

Pressure and temperature testing

The FlowCal balancing valve body is fitted with connections for the pressure and temperature test ports to read the pressure difference between inlet and outlet sides. This is useful when checking operation in the working range. In addition, drain valve (538202 FD -1/4" NPT; 538402 FD -1/2" NPT) can be connected for blowdown operations.

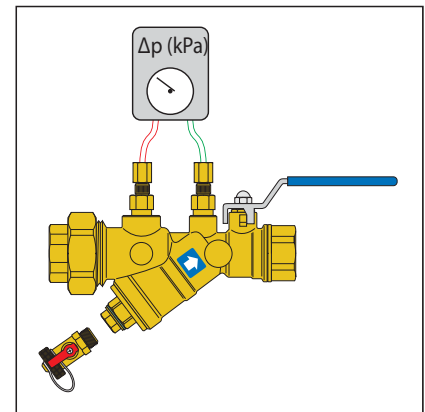

Sizing the circuit with FlowCal

Size the hydronic system with FlowCal automatic balancing valves as follows:

1. $\Delta P_{MAXCIRCUIT}$

Determine the pressure head loss for the zone circuit with the greatest pressure drop (flow resistance). This is true for any hydronic system with supply and return headers. As an example, this would be circuit #8 for the 2-pipe direct return system with circuits having identical resistance, illustrated to the right, as it is farthest from the pump. If, however, all circuits are not identical, choose the circuit with the greatest pressure drop.

2. $\Delta P_{MINFlowCal}$

Add the minimum differential operating pressure (2, 4, or 5 psid) required for the FlowCal model selected for the circuit with the greatest pressure drop.

3. PUMP HEAD = $\Delta P_{MAXCIRCUIT} + \Delta P_{MINFlowCal}$

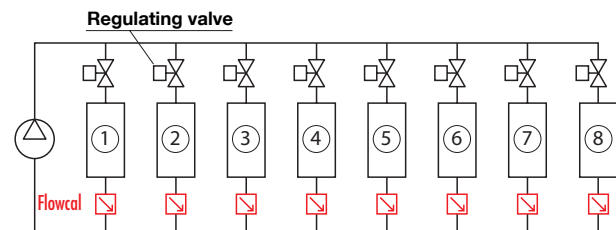

Differential pressures (Δp)

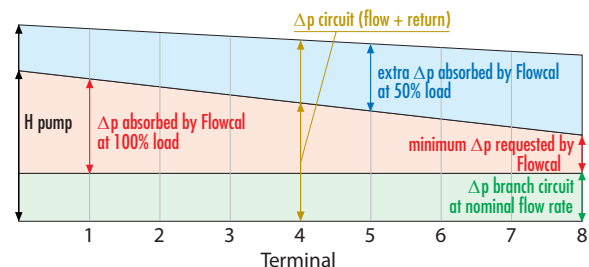

Applications of FlowCal ()

Installation of FlowCal

In air-conditioning systems, FlowCal devices must preferably be installed on the circuit return pipe. Some typical installation examples are given below.

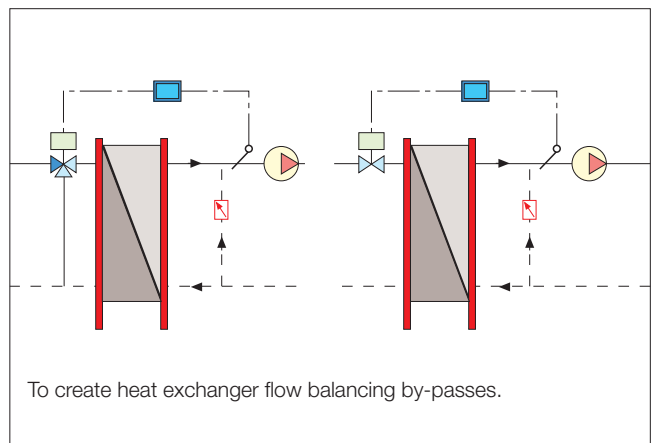
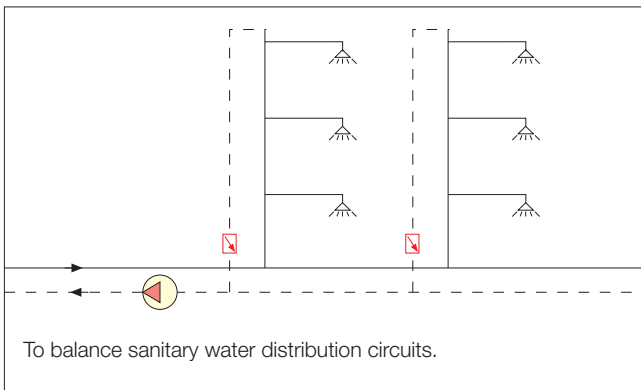
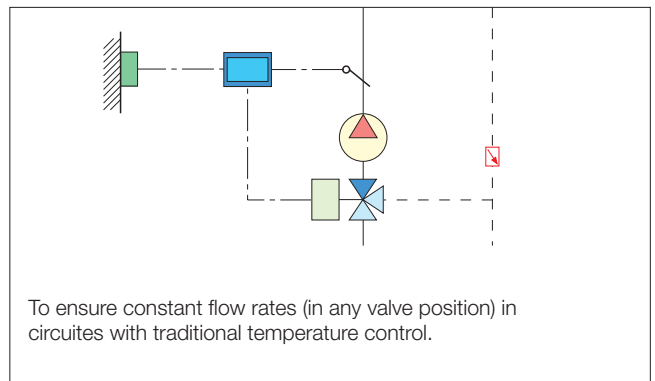
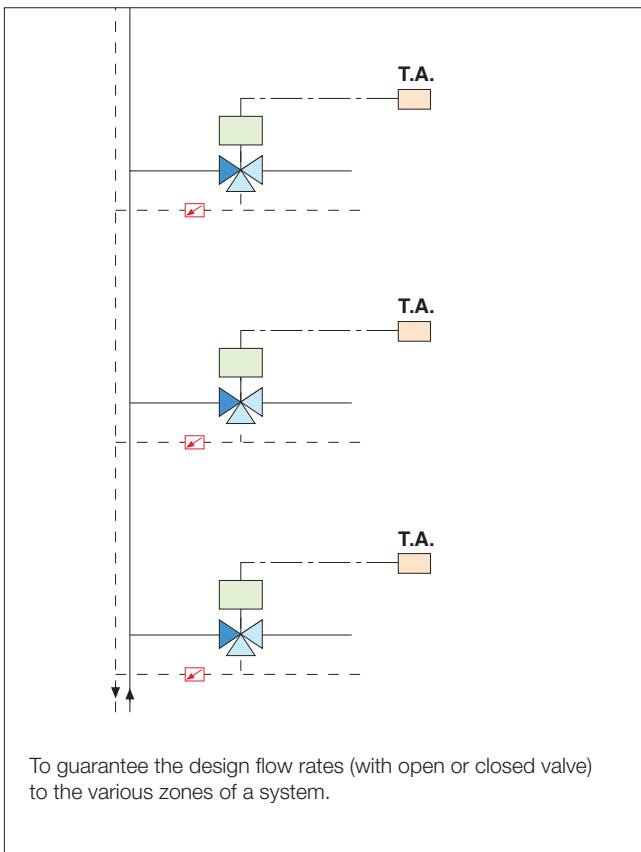
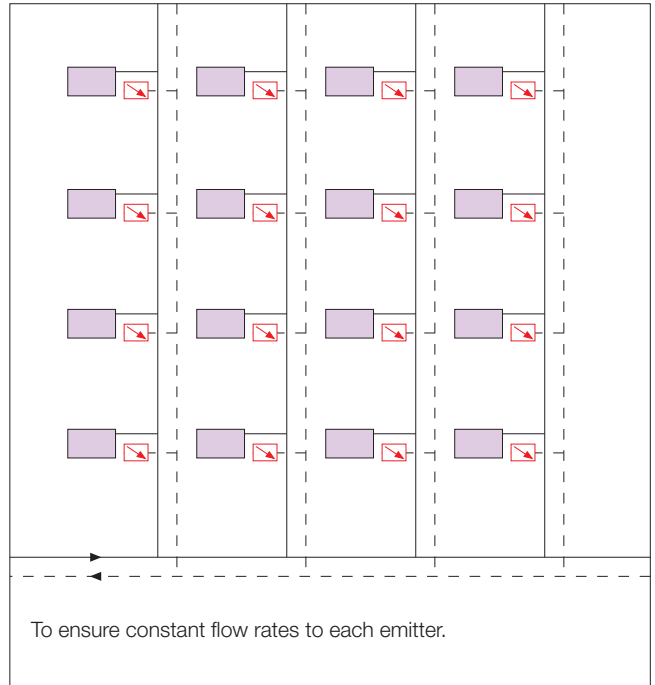
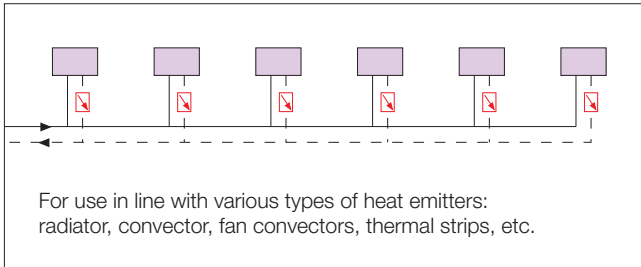

NOTES

Accessories

120 Y-Strainer

Combination of Y-strainer and ball valve.



Brass body.
Stainless steel filter cartridge.
Maximum working pressure: 400 psig (400 WOG)
Working temperature range: 32–212°F (0–100°C)
Strainer mesh diameter: 0.87 mm (20 mesh)
Connections: - body: 1/2", 3/4", 1", 1 1/4" FNPT union x FNPT, or sweat union x sweat
Pressure and temperature ports: 1/4" NPT
Drain port connection: 1/4" for 1/2" & 3/4"; 1/2" for 1" & 1 1/4"

Code*	Size	Cv
120.4A 000	1/2"	8.0
120.5A 000	3/4"	8.4
120.6A 000	1"	19.0
120.7A 000	1 1/4"	20.0

*4th digit: 1 = No PT ports; 3 = Factory-installed PT ports.

6th digit: 1 = NPT end connections; 9=Sweat end connections.

PT test ports

Fast-plug pressure/temperature test ports for FlowCal automatic flow balancing valves and the 120 series Y-strainer.

Their special construction enables rapid and accurate measurements without the need to leave expensive test equipment inline. The double-sealing core insures long and trouble-free service.

Can be used for:

- checking the operation of FlowCal balancing valve;
- checking for strainer clogging;
- checking the heat output of the emitter terminals.

Low Lead brass body.

Nordel Core.

Working temperature range: 0–275°F (-18–135°C)

Max. working pressure: 435 psi (30 bar).



Code	Size
100001A	1/4" NPT PT Test Port and Cap, standard size, 1 1/2" length (pair)



538

Drain valve with 3/4" garden hose connection.

Code	Size
538202 FD	1/4"
538402 FD	1/2"

SPECIFICATION SUMMARIES

121 series

Automatic flow balancing valve and integral ball valve, FlowCal. Brass body. Anti-scale low noise polymer cartridge. Stainless steel spring. EPDM seals. Chrome-plated brass ball. PTFE ball seat and stem seal. Zinc-plated steel lever with vinyl grip. Brass pressure and temperature port plugs. Medium: water and glycol solutions. Maximum working pressure rating is 400 psig (400 WOG). Maximum percentage of glycol 50%. Temperature range 32 - 212°F (0–100°C). Accuracy ± 10%. Δp Range 2–35 psid. Range of available flow rates: 0.5–21 GPM. Connections 1/2", 3/4", 1" and 1 1/4" NPT female or Sweat with union x NPT female or Sweat.



Caleffi North America, Inc.
3883 W. Milwaukee Road
Milwaukee, WI 53208
Tel: 414-238-2360 · Fax: 414-238-2366
sales@caleffi.com · www.caleffi.com
© Copyright 2019 Caleffi North America, Inc.