

**Electronic to Pneumatic Transducers
General Instructions**

Application

The CP-8551 and CP-8552 transducers receive a variable electronic input signal and produce a 3 to 15 psig (21 to 103 kPa) pneumatic output signal to position pneumatic damper and valve actuators in HVAC systems.

Features

- Durable enclosure with easily accessible wiring terminations
- Panel or DIN rail mounting for quick, snap-on installation
- Two-wire loop powered or three-wire voltage input
- High accuracy with low hysteresis
- Long-term driftless operation with high repeatability
- Low air consumption and large air flow capacity
- Control input protection from short circuit or reverse polarity

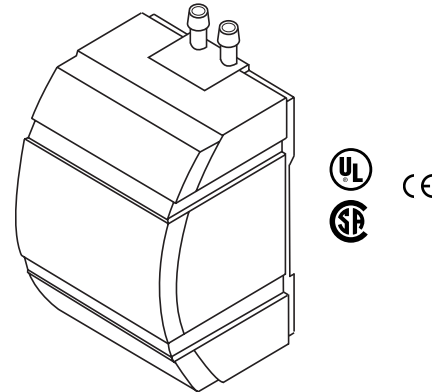

Applicable Literature

- TAC Environmental Controls Reference Manual, F-21683
- EN-123 Air Quality Requirements for Pneumatic HVAC Control Systems Engineering Information, F-22516
- TAC Pneumatic Products Catalog, F-27383

SPECIFICATIONS

Transducer Inputs

Input Signal:

CP-8551, 4 to 20 mA.

CP-8552, 4 to 20 mA, 6 to 9 V, and 0 to 10 V.

Input Impedance:

CP-8551, 550 Ω maximum, 400 Ω minimum.

CP-8552, 550 Ω maximum, 400 Ω minimum, 4 to 20 mA input; >10,000 Ω voltage input.

Power Input Requirements:

4 to 20 mA Input, None.

0 to 10 and 6 to 9 V Input, Requires 20 to 30 Vac, 3.9 VA (CP-8552), 50/60 Hz, or 24 to 30 Vdc power supply, 1.6 watts maximum.

Input Range Selection:

CP-8551, None.

CP-8552, Jumper selectable.

Air Supply Required: 20 psig (138 kPa) nominal, 30 psig (207 kPa) maximum. Clean, dry, oil free air required (refer to EN-123, F-22516).

Air Consumption for Sizing Air Compressor: Maximum 0.012 scfm (5.66 ml/s) @ 20 psig (138 kPa) supply.

Air Capacity for Sizing Air Mains: Minimum 550 scim (150.24 ml/s).

Air Connections: Male barbed fittings for flexible 1/4" O.D. pneumatic tubing.

Wiring Connections: Screw terminals for use with 16 to 22 AWG wire.

Transducer Outputs

Output Signal: 3 to 15 psig (21 to 103 kPa) nominal, Direct Acting.

Maximum Pneumatic Output: 1 to 18 psig (7 to 124 kPa).

Output Air Capacity & Pressure: 515 scim (141 ml/s) maximum with a 20 psig (138 kPa) supply.

Operating Characteristics:

Linearity, $\pm 1\%$ of span @ 75°F (24° C).

Hysteresis, 0.75% of span @ 75°F (24° C).

Adjustments:

CP-8551, None.

CP-8552,

4 to 20 mA Range None.

0 to 10 and 6 to 9 V Range Adjustable start point and span potentiometers.

Environment

Ambient Temperature Limits:

Shipping and Storage, -40 to 160°F (-40 to 71° C).

Operating, 32 to 140°F (0 to 60° C).

Humidity: 5 to 95% R.H., non-condensing.

Locations: NEMA Type 1.

Agency Listings:

UL 873: Underwriters Laboratories (File #E9429 Category Temperature-Indicating and Regulating Equipment).

CSA: Certified for use in Canada by Underwriters Laboratories. Canadian Standards C22.2 No. 24-93.

European Community: EMC Directive (89/336/EEC). Low Voltage Directive (72/23/EEC).

Accessories

| | |
|--------|--|
| AL-3X2 | Pressure gauge. |
| K-335 | In-line air filter. |
| B-371 | Branch tee. |
| M-127 | 90° drop ear elbow. |
| M-636 | 4 in. T and B wire tie. |
| P-610 | 35 mm DIN rail (1-3/8 W x 36 L x 3/10 H in). |

Note: Order the AL-3X2 Pressure Gauge, the B-371 Branch Tee, and the M-127 90° Drop Ear Elbow separately and field assemble to provide optional pressure indication for the CP-8551 and CP-8552 transducers.

TYPICAL APPLICATIONS (wiring diagram)

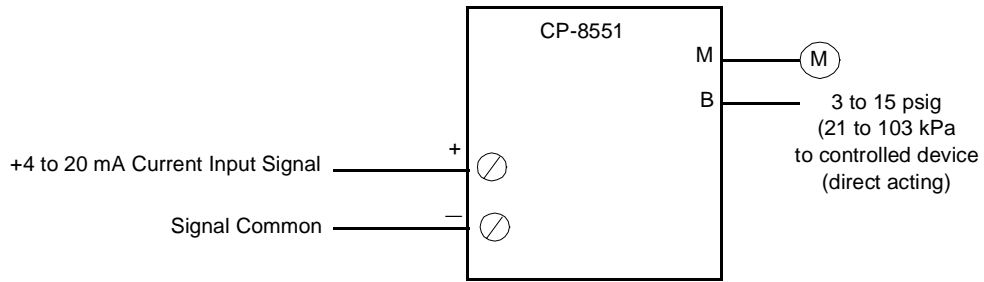
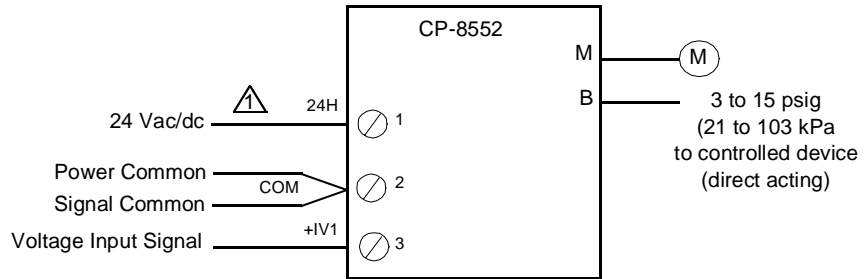

Figure-1 CP-8551 Typical Wiring.



 When multiple CP-8552s or other devices are powered by a common source, uniform wiring polarity must be maintained between all 24H and COM terminals. Check to ensure that the controller's COM terminal is not connected to any other ground reference.

Figure-2 CP-8552 Typical Wiring for Voltage Input.

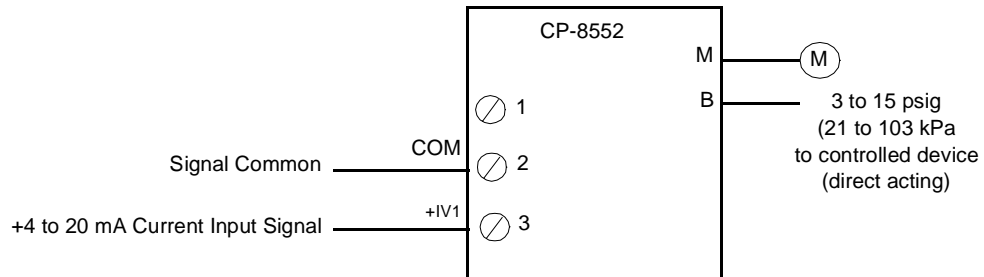

Figure-3 CP-8552 Typical Wiring for Current Input.

INSTALLATION

Inspection

Inspect the package for damage. If damaged, notify the appropriate carrier immediately. If undamaged, open the package and inspect the device for obvious damage. Return damaged products.

Requirements

- Wiring diagrams.
- Tools (not provided):
 - Screwdriver for mounting screws.
 - Drill and drill bit for mounting screws.
- Appropriate accessories.
- Two (2) # 6 mounting screws (not provided).
- M-636 4 in. T and B wire tie (not provided).
- Training: Installer must be a qualified, experienced technician.

Precautions



General

Warning:

- Disconnect the power supply (line power) before installation to prevent possible electrical shock and equipment damage.
 - Make all connections in accordance with the wiring diagram and in accordance with national and local electrical codes. Use copper conductors only.
 - Do not exceed the ratings of the device(s).
-

Supply Air

Caution:

- Particles in the air supply larger than 0.03 microns (4 mPa) may adversely affect the reliability and life of the transducer. If air supply is questionable, install a K-335 in line air filter between the main air supply and the main air port of the device.
 - A refrigerated air dryer, particulate filter, and coalescing filter should provide a quality air supply (refer to EN-123, F-22516).
 - Compressor oil must be non-paraffin mineral base or naphtha base. Synthetic base oils will destroy pneumatic controls and void the warranty.
-

Location

Caution:

- NEMA Type 1 devices are intended for indoor use primarily to provide a degree of protection against contact with the enclosed equipment.
 - Do not locate unit in areas subject to incidental contact, vibration, severe mechanical shock, excessive moisture, or corrosive fumes.
-

Mounting

Refer to Figure-5 for mounting dimensions.

Caution: The CP-8551 and CP-8552 transducers must be mounted within 5° of the upright position. (Refer to "UP" arrow on printed circuit board.)

1. Remove transducer cover by grasping both sides of cover and pulling gently.
2. Select the mounting location.
3. Rail mount transducer on a vertical surface by snapping to a 35 mm DIN mounting rail (not provided) or wall mount with two screws (not provided). Multiple units can be mounted side by side on a DIN mounting rail.
4. Pull wires through bottom of enclosure and make necessary connections.
5. Position wires to clear the wiring access hole in the cover.
6. Use a small plastic wire tie to secure the wires to the strain relief tab provided on the mounting base to the left of the wiring terminations (Figure-4).
7. Replace cover and make pneumatic connections.

Wiring

Use 16 to 22 AWG wire for Class II wiring terminals. Use flexible 1/4" O.D. tubing for main and branch male pneumatic connections.

Jumper Selection (CP-8552 Only)

Note: The CP-8552 is factory calibrated for the 4 to 20 mA and 0 to 10 V ranges. Switching to the 6 to 9 V range requires recalibration of the start point and span potentiometers.

The CP-8552 has three jumper selectable input ranges. Refer to Figure-4 for jumper block detail. Make proper jumper selection as follows:

1. Choose input range.
2. Consult Table-1 for jumper position.
3. Place jumper over square posts on appropriate lettered block (Figure-4).
4. Calibrate by performing appropriate CHECKOUT procedure.

Table-1 CP-8552 Jumper Selection.

| Range | x = Insert jumper at position shown in chart. | | |
|------------------------|---|---|---|
| | A | B | C |
| 4 to 20 mA | X | | |
| 6 to 9 V | | X | |
| 0 to 10 V ^a | | | X |

^a CP-8552 factory supplied at 0 to 10 V input.

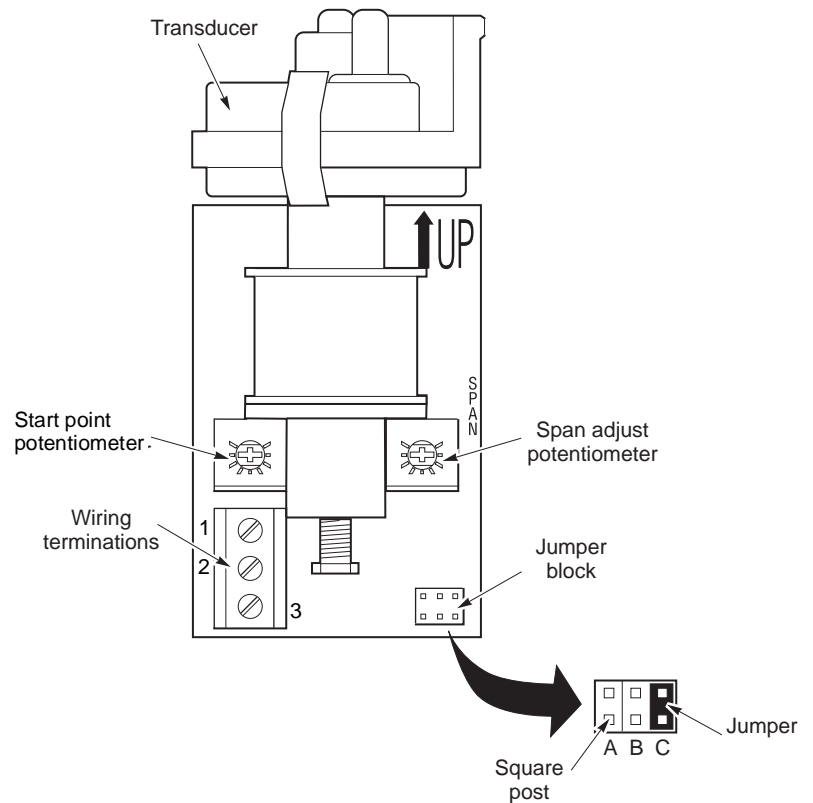

Figure-4 CP-8552 Internal View.

Controller Output Scaling

In order to properly control the actuator, the output of the controller must be scaled appropriately. Table-2 below illustrates the correct output which corresponds to the electronic input of the transducer.

Table-2 Electronic/Pneumatic Transducer Conversion Chart.

| Output (PSI) | Electronic Input | | |
|-----------------|------------------|---------------|----------------|
| | 4-20 mA | 6-9 Volts* | 0-10 Volts* |
| 3 | 4.00 | 6.00 | 0.00 |
| 4 | 5.33 | 6.25 | 0.83 |
| 5 | 6.67 | 6.50 | 1.67 |
| 6 | 8.00 | 6.75 | 2.50 |
| 7 | 9.33 | 7.00 | 3.33 |
| 8 | 10.67 | 7.25 | 4.17 |
| 9 | 12.00 | 7.50 | 5.00 |
| 10 | 13.33 | 7.75 | 5.83 |
| 11 | 14.67 | 8.00 | 6.67 |
| 12 | 16.00 | 8.25 | 7.50 |
| 13 | 17.33 | 8.50 | 8.33 |
| 14 | 18.67 | 8.75 | 9.17 |
| 15 | 20.00 | 9.00 | 10.00 |

* Applies only to CP-8552.

CHECKOUT

4 to 20 mA Range (CP-8551 and CP-8552)

Note: The CP-8551 and CP-8552 4 to 20 mA span and start point potentiometers are not field adjustable.

To check transducer operation:

1. Check for foreign material such as dirt or oil in the air supply. Also check for clogged filters. Supply air contamination by dirt or oil is the most likely cause of malfunction.
2. Verify that the unit is mounted upright and wired correctly.
3. Verify that 20 psig (138 kPa) main air is present.
4. Verify with a digital multimeter that a 4 to 20 mA_{dc} signal is present and of correct polarity.
5. Adjust the input signal to 4 mA. Branch pressure should be 3 psig \pm 1.0 (21 kPa).
6. Adjust the input signal to 20 mA. Branch pressure (direct acting) should be 15 psig \pm 1.0 (103 kPa).
7. Unit is functional if correct pressures are indicated. Replace an inoperative transducer with a functional unit.

0 to 10 or 6 to 9 V Range (CP-8552 only)

To check transducer operation:

1. Check for foreign material such as dirt or oil in the air supply. Also check for clogged filters. Supply air contamination by dirt or oil is the most likely cause of malfunction.
2. Verify that the unit is mounted upright and wired correctly.
3. Verify that 24 Vac power is available and 20 psig (138 kPa) main air is present.
4. Verify with a digital voltmeter that an input signal between 0 to 10 or 6 to 9 V is present and of correct polarity.
5. Use a digital voltmeter to verify the presence of the correct power supply voltage between terminals 1 and 2.
6. Adjust the input signal to bottom of range (0 or 6 V).
7. Branch pressure should be 3 psig (21 kPa). If not, adjust start point potentiometer (Figure-4) to obtain a 3 psig (21 kPa) output.
8. Adjust input to top of range (9 or 10 V).
9. Branch pressure should be 15 psig (103 kPa). If not, adjust SPAN potentiometer (Figure-4) to obtain a 15 psig (103 kPa) output.
10. Recheck steps 6 through 9.
11. Unit is functional if correct pressures are indicated. Replace an inoperative transducer with a functional unit.

MAINTENANCE

Regular maintenance of the total system is recommended to assure sustained optimum performance.

FIELD REPAIR

Field repair is not recommended. Replace an inoperative transducer with a functional unit.

DIMENSIONAL DATA

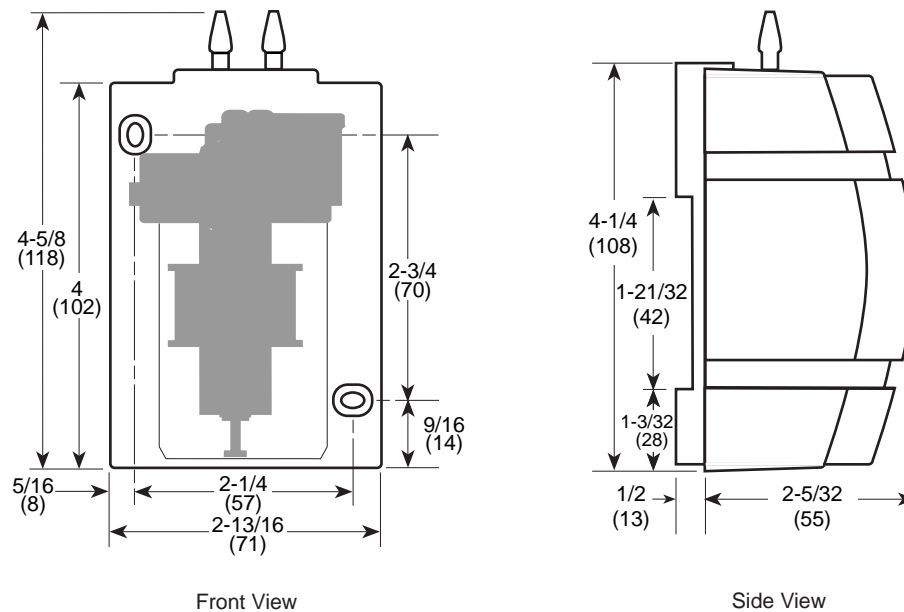

Dimensions shown are in inches (mm).

Figure-5 CP-8551 and CP-8552 Dimensions.

Copyright 2008, TAC
All brand names, trademarks and registered
trademarks are the property of their respective
owners. Information contained within this
document is subject to change without notice.

F-26159-5

TAC
1354 Clifford Avenue
P.O. Box 2940
Loves Park, IL 61132-2940
www.tac.com

t.a.c. [®]
by **Schneider Electric**