

# CHA24W-410-650 SERIES

AUGUST 23, 1994

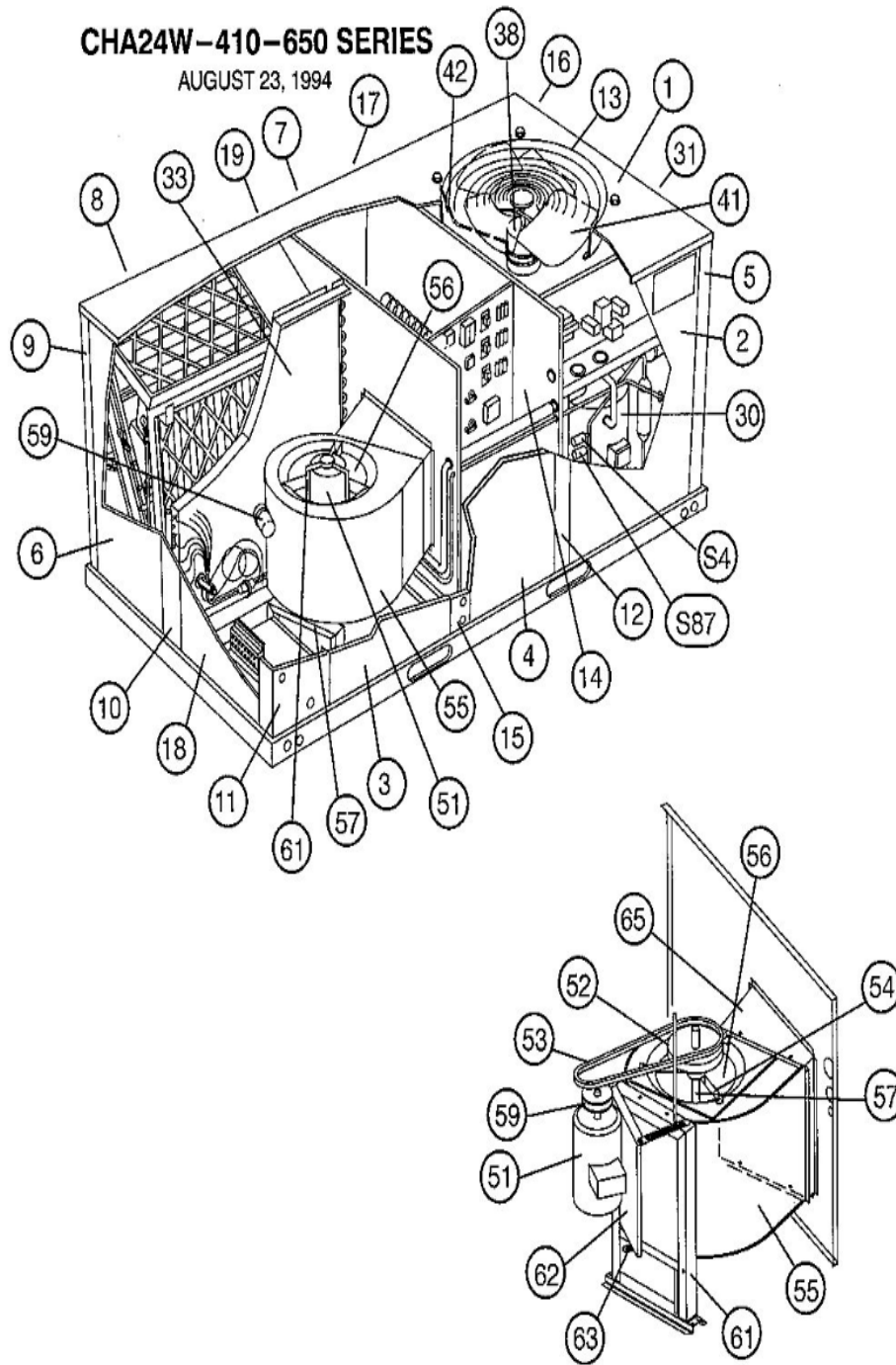

# CHA24W-410-650 CONTROL PANEL

AUGUST 23, 1994

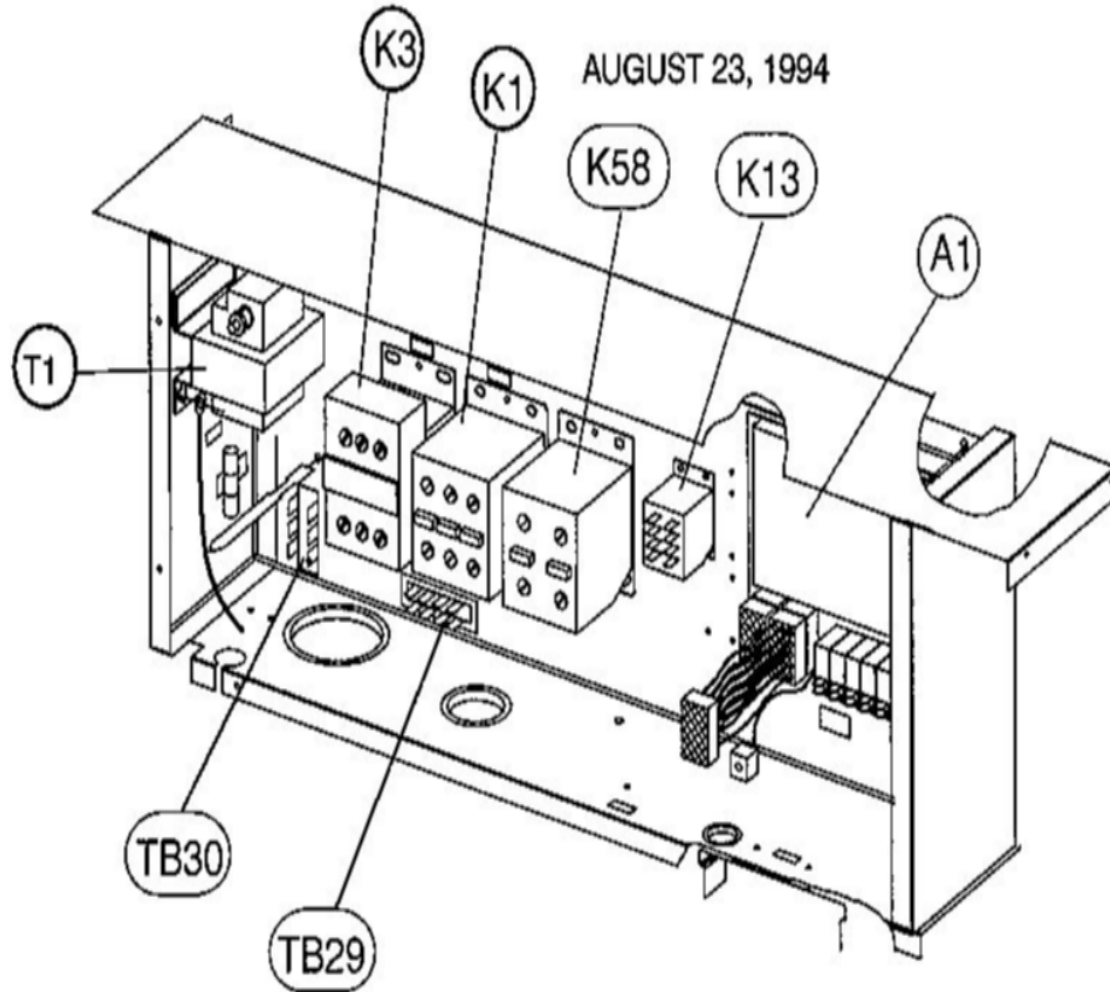

### REMD24M-ECONOMIZER (Factory Installed)

AUGUST 8, 1994

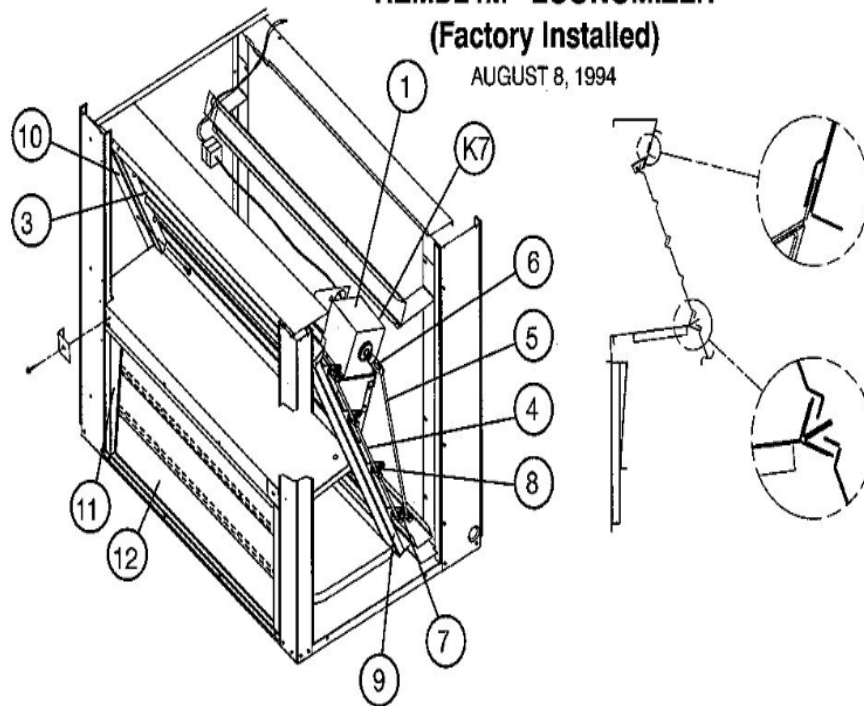

### OUTSIDE AIR DAMPER (Factory Installed)

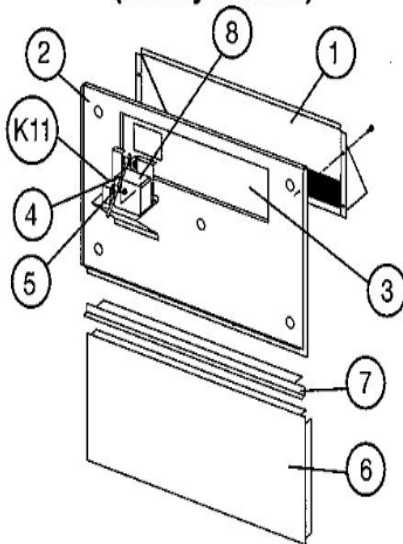

Callout	Name	Quantity	Description
LC KIT	KIT-LO PRESS SWITCHPRICE BOOK CAT #70L71 Cat #: Model/Part #:	1	

**Note:**

There are no technical notes for this product.