

CHA16-2553W-2 WALMART CONTROL PANEL

NOVEMBER 18, 1992

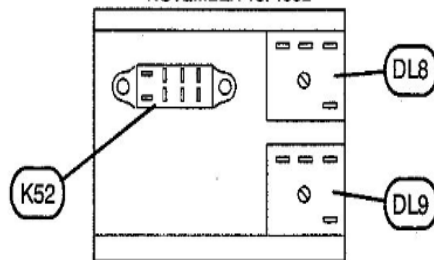

COMPRESSOR CYCLE CONTROL
(LOCATED IN FILTER COMPARTMENT)

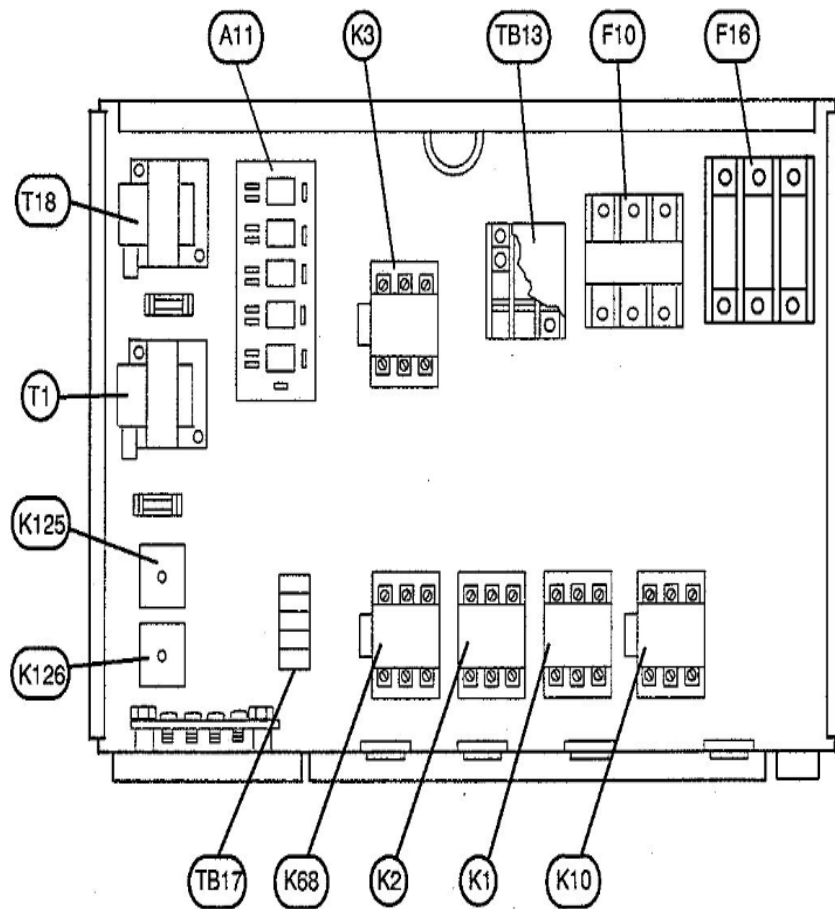

CHA16-2553W-3-4 WALMART CONTROL PANEL

FEBRUARY 8, 1993

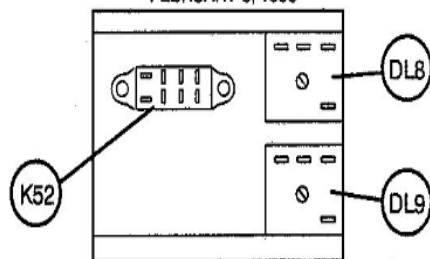

COMPRESSOR CYCLE CONTROL
(LOCATED IN FILTER COMPARTMENT)

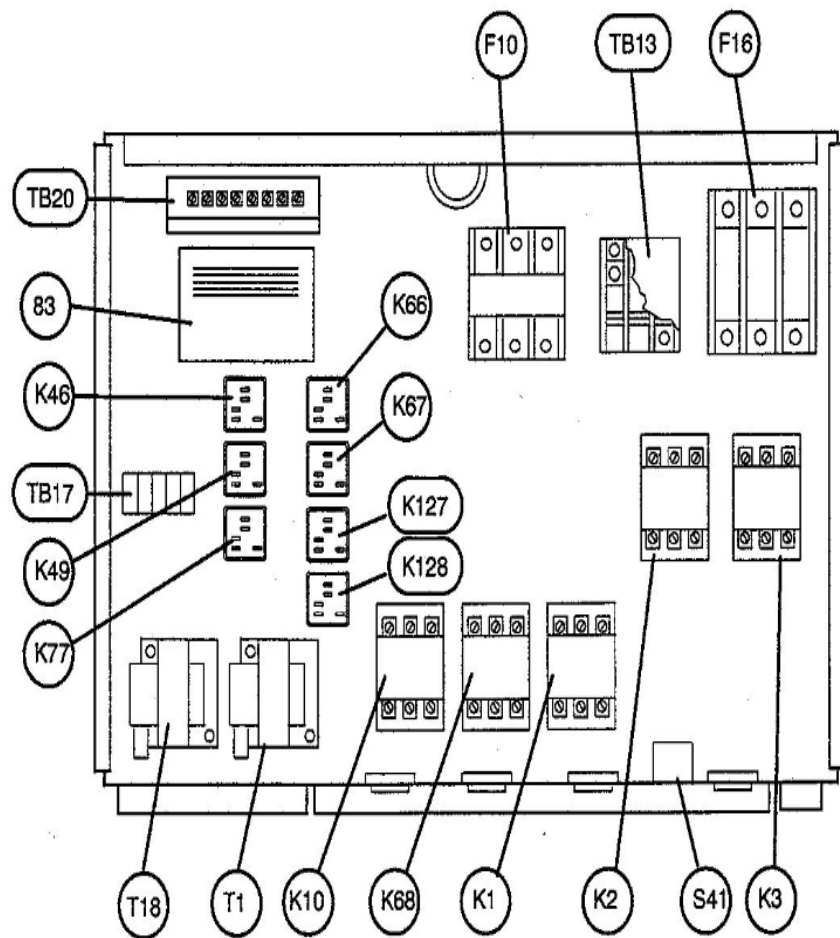

CHA16-2553W-2 WALMART NOVAR CONTROL PANEL (Filter Compartment)

APRIL 6, 1993

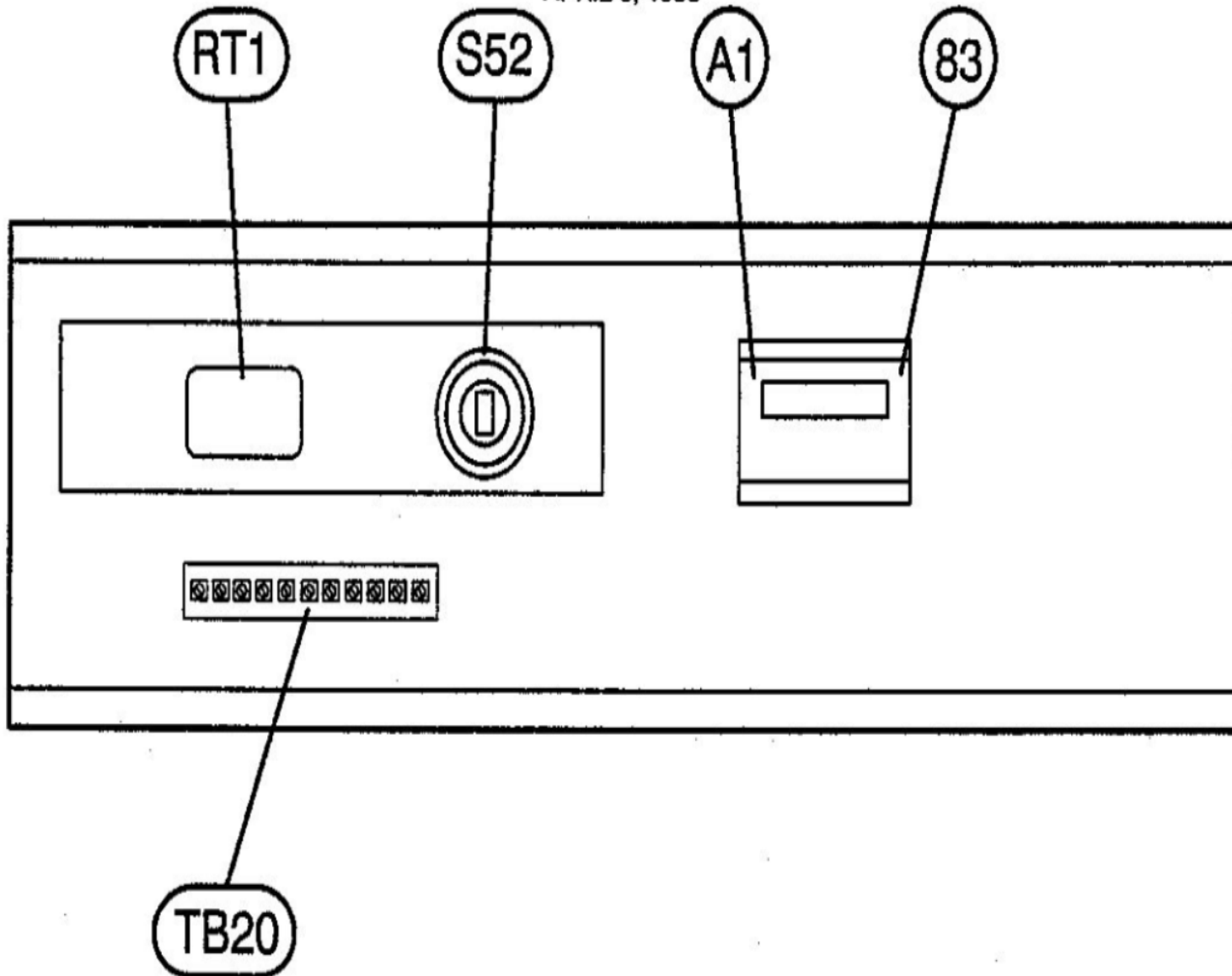

RT1

S52

**CHA16-2553W-3-4 WALMART
NOVAR CONTROL PANEL
(Filter Compartment)**

APRIL 16, 1993

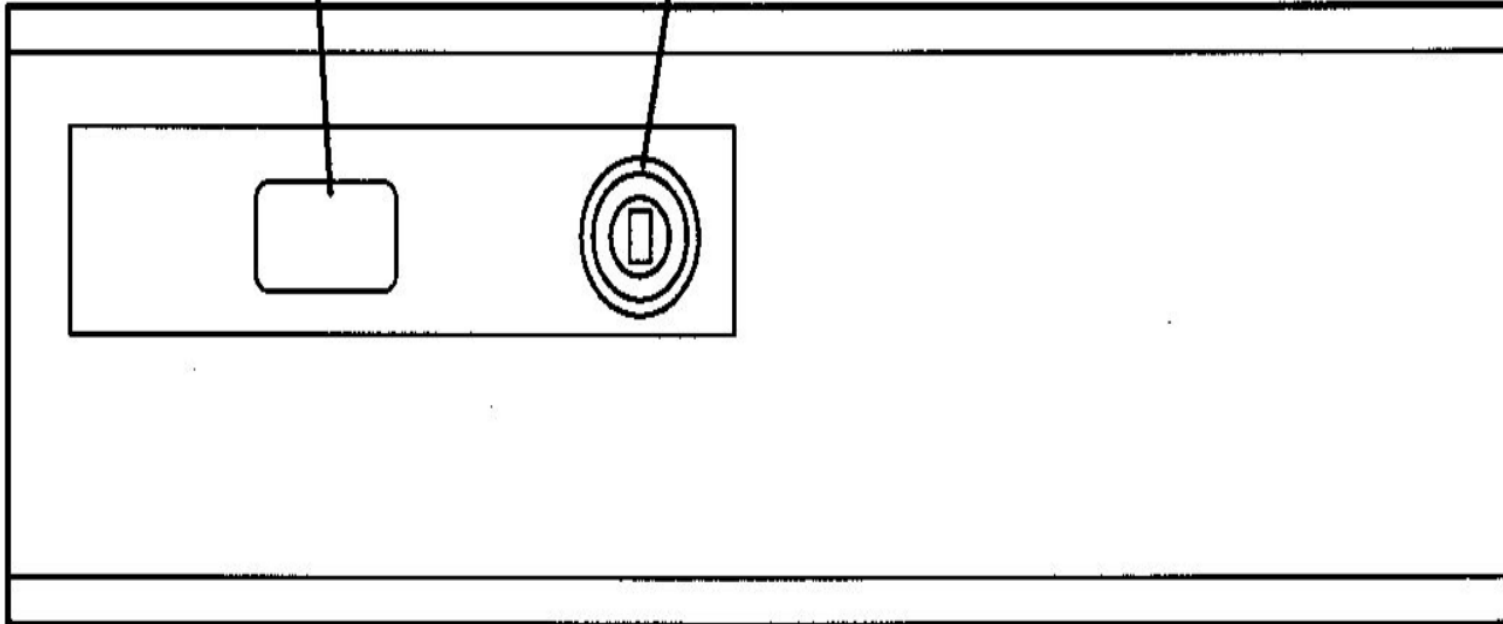

CHA16-2553W -2 SERIES

MAY 6, 1993

