

INSTALLATION, OPERATING AND SERVICE INSTRUCTIONS FOR

SCG™ GAS - FIRED BOILER



As an ENERGY STAR® Partner, Burnham by U.S. Boiler Company has determined that the SCG meets the ENERGY STAR® guidelines for energy efficiency established by the United States Environmental Protection Agency (EPA).

For service or repairs to boiler, call your heating contractor. When seeking information on boiler, provide Boiler Model Number and Serial Number as shown on Rating Label.

Boiler Model Number SCG	Boiler Serial Number	Installation Date
Heating Contractor		Phone Number
Address		



IMPORTANT INFORMATION - READ CAREFULLY

NOTE: The equipment shall be installed in accordance with those installation regulations enforced in the area where the installation is to be made. These regulations shall be carefully followed in all cases. Authorities having jurisdiction shall be consulted before installations are made.

All wiring on boilers installed in the USA shall be made in accordance with the National Electrical Code and/or local regulations.

All wiring on boilers installed in Canada shall be made in accordance with the Canadian Electrical Code and/or local regulations.

The New York City Department of Buildings has approved the SCG™ Series boiler: Approval No. MEA 5-06-E.

The City of New York requires a Licensed Master Plumber supervise the installation of this product.

The Massachusetts Board of Plumbers and Gas Fitters has approved the SCG™ Series boiler. See the Massachusetts Board of Plumbers and Gas Fitters website, http://license.reg.state.ma.us/pubLic/pl_products/pb_pre_form.asp for the latest Approval Code or ask your local Sales Representative.

The Commonwealth of Massachusetts requires this product to be installed by a Licensed Plumber or Gas Fitter.

The following terms are used throughout this manual to bring attention to the presence of hazards of various risk levels, or to important information concerning product life.

DANGER

Indicates an imminently hazardous situation which, if not avoided, will result in death, serious injury or substantial property damage.

CAUTION

Indicates a potentially hazardous situation which, if not avoided, may result in moderate or minor injury or property damage.

WARNING

Indicates a potentially hazardous situation which, if not avoided, could result in death, serious injury or substantial property damage.

NOTICE

Indicates special instructions on installation, operation, or maintenance which are important but not related to personal injury hazards.

DANGER

DO NOT store or use gasoline or other flammable vapors or liquids in the vicinity of this or any other appliance.

If you smell gas vapors, DO NOT try to operate any appliance - DO NOT touch any electrical switch or use any phone in the building. Immediately, call the gas supplier from a remotely located phone. Follow the gas supplier's instructions or if the supplier is unavailable, contact the fire department.

Special Installation Requirements for Massachusetts

- A. For all side wall horizontally vented gas fueled equipment installed in every dwelling, building or structure used in whole or in part for residential purposes and where the side wall exhaust vent termination is less than seven (7) feet above grade, the following requirements shall be satisfied:
1. If there is no carbon monoxide detector with an alarm already installed in compliance with the most current edition of NFPA 720, NFPA 70 and the Massachusetts State Building Code in the residential unit served by the side wall horizontally vented gas fueled equipment, a battery operated carbon monoxide detector with an alarm shall be installed in compliance with the most current edition of NFPA 720, NFPA 70 and the Massachusetts State Building Code.
 2. In addition to the above requirements, if there is not one already present, a carbon monoxide detector with an alarm and a battery back-up shall be installed and located in accordance with the installation requirements supplied with the detector on the floor level where the gas equipment is installed. The carbon monoxide detector with an alarm shall comply with 527 CMR, ANSI/UL 2034 Standards or CSA 6.19 and the most current edition of NFPA 720. In the event that the requirements of this subdivision can not be met at the time of the completion of the installation of the equipment, the installer shall have a period of thirty (30) days to comply with this requirement; provided, however, that during said thirty (30) day period, a battery operated carbon monoxide detector with an alarm shall be installed in compliance with the most current edition of NFPA 720, NFPA 70 and the Massachusetts State Building Code. In the event that the side wall horizontally vented gas fueled equipment is installed in a crawl space or an attic, the carbon monoxide detector may be installed on the next adjacent habitable floor level. Such detector may be a battery operated carbon monoxide detector with an alarm and shall be installed in compliance with the most current edition of NFPA 720, NFPA 70 and the Massachusetts State Building Code.
 3. A metal or plastic identification plate shall be permanently mounted to the exterior of the building at a minimum height of eight (8) feet above grade directly in line with the exhaust vent terminal for the horizontally vented gas fueled heating appliance or equipment. The sign shall read, in print size no less than one-half (1/2) inch in size, **“GAS VENT DIRECTLY BELOW. KEEP CLEAR OF ALL OBSTRUCTIONS”**.
 4. A final inspection by the state or local gas inspector of the side wall horizontally vented equipment shall not be performed until proof is provided that the state or local electrical inspector having jurisdiction has granted a permit for installation of carbon monoxide detectors and alarms as required above.
- B. EXEMPTIONS: The following equipment is exempt from 248 CMR 5.08(2)(a) 1 through 4:
1. The equipment listed in Chapter 10 entitled “Equipment Not Required To Be Vented” in the most current edition of NFPA 54 as adopted by the Board; and
 2. Product Approved side wall horizontally vented gas fueled equipment installed in a room or structure separate from the dwelling, building or structure used in whole or in part for residential purposes.
- C. When the manufacturer of Product Approved side wall horizontally vented gas equipment provides a venting system design or venting system components with the equipment, the instructions for installation of the equipment and the venting system shall include:
1. A complete parts list for the venting system design or venting system; and
 2. Detailed instructions for the installation of the venting system design or the venting system components.
- D. When the manufacturer of a Product Approved side wall horizontally vented gas fueled equipment does not provide the parts for venting flue gases, but identifies “special venting systems”, the following shall be satisfied:
1. The referenced “special venting system” instructions shall be included with the appliance or equipment installation instructions; and
 2. The “special venting systems” shall be Product Approved by the Board, and the instructions for that system shall include a parts list and detailed installation instructions.
- E. A copy of all installation instructions for all Product Approved side wall horizontally vented gas fueled equipment, all venting instructions, all parts lists for venting instructions, and/or all venting design instructions shall remain with the appliance or equipment at the completion of the installation.

WARNING

This boiler requires regular maintenance and service to operate safely. Follow the instructions contained in this manual.

Improper installation, adjustment, alteration, service or maintenance can cause property damage, personal injury or loss of life. Read and understand the entire manual before attempting installation, start-up operation, or service. Installation and service must be performed only by an experienced, skilled, and knowledgeable installer or service agency.

This boiler must be properly vented.

This boiler needs fresh air for safe operation and must be installed so there are provisions for adequate combustion and ventilation air.

The interior of the venting system must be inspected and cleaned before the start of the heating season and should be inspected periodically throughout the heating season for any obstructions. A clean and unobstructed venting system is necessary to allow noxious fumes that could cause injury or loss of life to vent safely and will contribute toward maintaining the boiler's efficiency.

Installation is not complete unless a pressure relief valve is installed into the tapping located on top of appliance. - See the Water Piping and Trim Section of this manual for details.

This boiler is supplied with safety devices which may cause the boiler to shut down and not re-start without service. If damage due to frozen pipes is a possibility, the heating system should not be left unattended in cold weather; or appropriate safeguards and alarms should be installed on the heating system to prevent damage if the boiler is inoperative.

This boiler contains very hot water under high pressure. Do not unscrew any pipe fittings nor attempt to disconnect any components of this boiler without positively assuring the water is cool and has no pressure. Always wear protective clothing and equipment when installing, starting up or servicing this boiler to prevent scald injuries. Do not rely on the pressure and temperature gauges to determine the temperature and pressure of the boiler. This boiler contains components which become very hot when the boiler is operating. Do not touch any components unless they are cool.

Boiler materials of construction, products of combustion and the fuel contain alumina, silica, heavy metals, carbon monoxide, nitrogen oxides, aldehydes and/or other toxic or harmful substances which can cause death or serious injury and which are known to the state of California to cause cancer, birth defects and other reproductive harm. Always use proper safety clothing, respirators and equipment when servicing or working nearby the appliance.

Failure to follow all instructions in the proper order can cause personal injury or death. Read all instructions, including all those contained in component manufacturers manuals which are provided with the boiler before installing, starting up, operating, maintaining or servicing.

Keep boiler area clear and free from combustible materials, gasoline and other flammable vapors or liquids.

All cover plates, enclosures and guards must be in place at all times.

NOTICE

This boiler has a limited warranty, a copy of which is printed on the back of this manual. It is the responsibility of the installing contractor to see that all controls are correctly installed and are operating properly when the installation is complete.

Table of Contents

I. Pre-Installation.....	7	VI. Electrical.....	54
II. Unpack Boiler	8	VII. Modular Installation	63
III. Venting/Air Intake Piping	9	VIII. System Start-up	65
IV. Water Piping and Trim	46	IX. Service	72
V. Gas Piping.....	51	X. Repair Parts.....	78

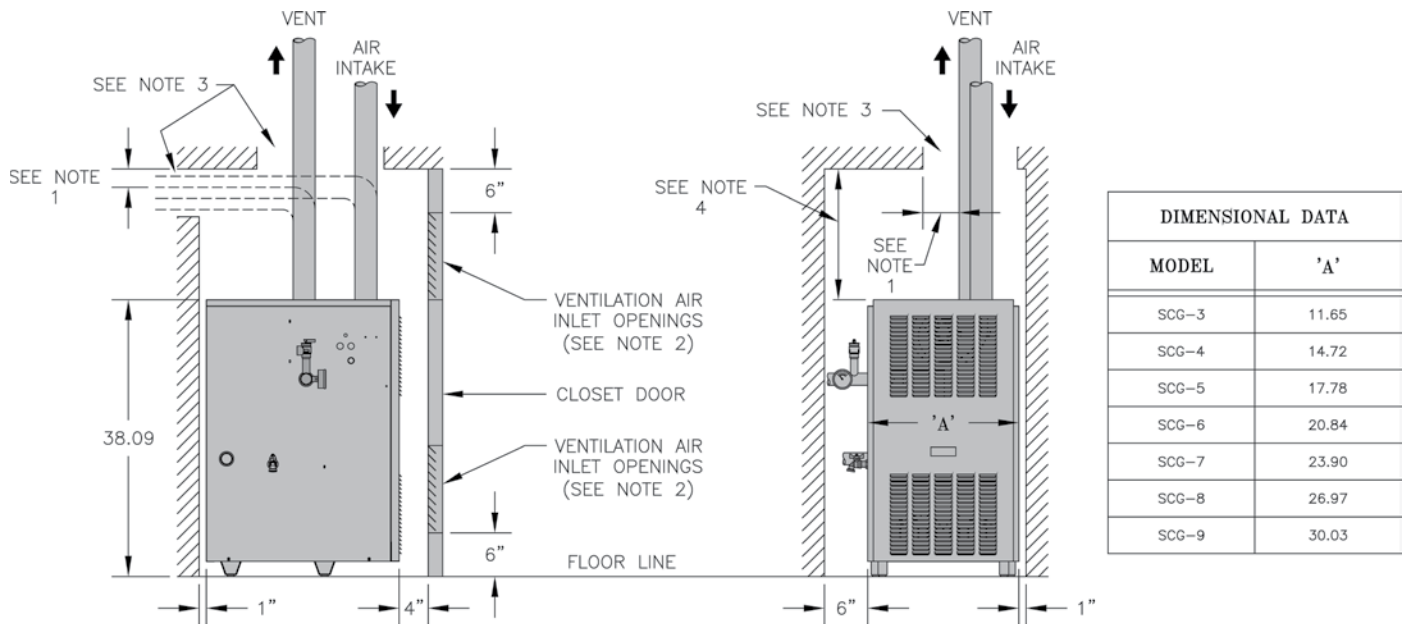

NOTES:

1. VENT PIPE MINIMUM CLEARANCE TO COMBUSTIBLE MATERIAL IS FOUR (4) INCHES WHEN VENT IS INSTALLED IN A FULLY ENCLOSED CHASED APPLICATION OR THREE (3) INCHES WHEN VENT IS INSTALLED WITH AT LEAST ONE SIDE OPEN, SIMILAR TO A JOIST BAY APPLICATION.
2. AREA OF EACH OPENING, 1 SQ. INCH FOR EACH 1000 BTUH INPUT – WITH MINIMUM OF 100 SQ. INCHES. HEIGHT OF OPENING SHOULD BE HALF THE WIDTH.
3. USE DOUBLE WALL THIMBLE WHEN PENETRATING A COMBUSTIBLE WALL.
4. 18 INCH CLEARANCE REQUIRED FOR CLOSET INSTALLATION.
4 INCH CLEARANCE REQUIRED FOR OPEN INSTALLATION.

Figure 1: Minimum Clearances to Combustibles

DIMENSIONAL DATA	
MODEL	'A'
SCG-3	11.65
SCG-4	14.72
SCG-5	17.78
SCG-6	20.84
SCG-7	23.90
SCG-8	26.97
SCG-9	30.03

CONNECTION SIZES (DIMENSIONS IN INCHES)					
MODEL	'SUPPLY'	RETURN	VENT	AIR INTAKE	RELIEF VALVE
SCG-3	1½ NPT	1½ NPT	3	3	¾ NPT
SCG-4	1½ NPT	1½ NPT	3	3	¾ NPT
SCG-5	1½ NPT	1½ NPT	3	4	¾ NPT
SCG-6	1½ NPT	1½ NPT	3	4	¾ NPT
SCG-7	1½ NPT	1½ NPT	3	5	¾ NPT
SCG-8	1½ NPT	1½ NPT	4	5	¾ NPT
SCG-9	1½ NPT	1½ NPT	4	5	¾ NPT

DIMENSIONAL DATA	
MODEL	'A'
SCG-3	11.65
SCG-4	14.72
SCG-5	17.78
SCG-6	20.84
SCG-7	23.90
SCG-8	26.97
SCG-9	30.03

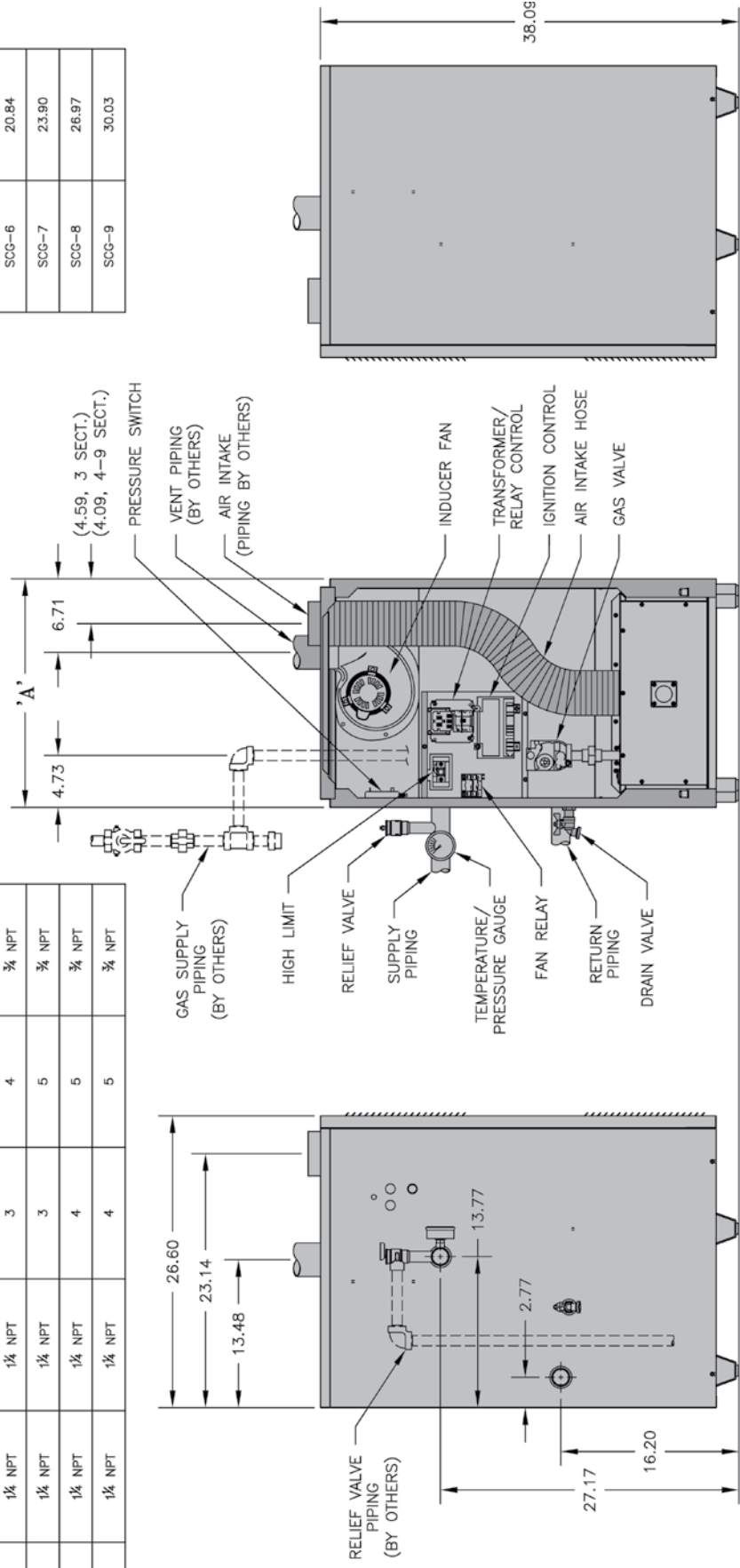

(LESS FRONT PANEL)

Figure 2: Dimensions

I. Pre-Installation

WARNING

If you do not follow these instructions exactly, a fire or explosion may result causing property damage or personal injury.

DANGER

Do not install boiler where gasoline or other flammable vapors or liquids, or sources of hydrocarbons (i.e. bleaches, cleaners, chemicals, sprays, paint removers, fabric softeners, etc.) are used or stored.

NOTICE

Due to the low water content of the boiler, mis-sizing of the boiler with regard to the heating system load will result in excessive boiler cycling and accelerated component failure. U.S. Boiler DOES NOT warrant failures caused by mis-sized boiler applications. DO NOT oversize the boiler to the system. Modular boiler installations greatly reduce the likelihood of boiler oversizing.

- A. Installation must conform** to the requirements of the authority having jurisdiction. In the absence of such requirements, installation must conform to the *National Fuel Gas Code*, NFPA 54/ANSI Z223.1, and/or CAN/CSA B149.1 Installation Codes.
- B. Appliance is design certified** for installation on combustible flooring. Do not install boiler on carpeting.
- C. Provide clearance** between boiler jacket and combustible material in accordance with local fire ordinance. Refer to Figure 1 for minimum listed clearance from combustible material. Recommended service clearance is 24 inches from left side, right side and front. Service clearances may be reduced to minimum clearances to combustible materials.
- D. Install on level floor.** For basement installation provide solid base such as concrete, if floor is not level or if water may be encountered on floor around boiler. Floor must be able to support weight of boiler, water and all additional system components.
- E. Protect gas ignition system components** from water (dripping, spraying, rain, etc.) during boiler operation and service (circulator replacement, condensate trap, control replacement, etc.).

- F. Provide combustion and ventilation air** in accordance with applicable provisions of local building codes, or: USA - *National Fuel Gas Code*, NFPA 54/ANSI Z223.1, Air for Combustion and Ventilation; Canada - *Natural Gas or Propane Installation Code*, CAN/CSA-B149.1.

WARNING

Adequate combustion and ventilation air must be provided to assure proper combustion.

The following guideline is based on the *National Fuel Gas Code*, NFPA 54/ANSI Z223.1.

1. Determine volume of space (boiler room). Rooms communicating directly with space (through openings not furnished with doors) are considered part of space.
Volume [ft³] = Length [ft] x Width [ft] x Height [ft]
2. Determine Total Input of all appliances in space. Round result to nearest 1,000 Btu per hour (Btuh).
3. Determine type of space. Divide Volume by Total Input.
 - a. If result is greater than or equal to 50 ft³ per 1,000 Btuh, space is considered an *unconfined space*.
 - b. If result is less than 50 ft³ per 1,000 Btuh, space is considered a *confined space*.
4. Determine building type. A building of *unusually tight construction* has the following characteristics:
 - a. Walls and ceiling exposed to outside atmosphere have a continuous water vapor retarder with a rating of 1 perm or less with openings gasketed and sealed, and;
 - b. Weather-stripping has been added on openable windows and doors, and;
 - c. Caulking or sealants applied in joints around window and door frames, between sill plates and floors, between wall-ceiling joints, between wall panels, at plumbing and electrical penetrations, and at other openings.
5. For boiler located in an *unconfined space in a building of other than unusually tight construction*, adequate combustion and ventilation air is normally provided by fresh air infiltration through cracks around windows and doors.

NOTICE

Boilers operated with direct vent (sealed combustion) are exempt from needing provisions for combustion air from the room, provided air intake piping is installed per Code and the instructions in the manual.

6. For boiler located within *unconfined space in building of unusually tight construction* or within *confined space*, provide outdoor air through two permanent openings which communicate directly or by duct with the outdoors or spaces (crawl or attic) freely communicating with the outdoors. Locate one opening within twelve (12) inches of top of space. Locate remaining opening within twelve (12) inches of bottom of space. Minimum dimension of air opening is three (3) inches. Size each opening per following:
- Direct communication with outdoors. Minimum free area of one (1) square inch per 4,000 Btu per hour input of all equipment in space.
 - Vertical ducts. Minimum free area of one (1) square inch per 4,000 Btu per hour input of all equipment in space. Duct cross-sectional area shall be same as opening free area.

- Horizontal ducts. Minimum free area of one (1) square inch per 2,000 Btu per hour input of all equipment in space. Duct cross-sectional area shall be same as opening free area.

Alternate method for boiler located within confined space. Use indoor air if two permanent openings communicate directly with additional space(s) of sufficient volume such that combined volume of all spaces meet criteria for unconfined space. Size each opening for minimum free area of one (1) square inch per 1,000 Btu per hour input of all equipment in spaces, but not less than 100 square inches.

7. Combustion Air/Ventilation Duct Louvers and Grilles. Equip outside openings with louvers to prevent entrance of rain and snow, and screens to prevent entrance of insects and rodents. Louvers and grilles must be fixed in open position or interlocked with equipment to open automatically before burner operation. Screens must not be smaller than ¼ inch mesh.

Consider the blocking effect of louvers, grilles and screens when calculating the opening size to provide the required free area. If free area of louver or grille is not known, assume wood louvers have 20-25 percent free area and metal louvers and grilles have 60-75 percent free area.

CAUTION

If using indoor air for combustion (see Venting Section - Indoor Air), avoid operating this boiler in an environment where saw dust, loose insulation fibers, dry wall dust, etc. are present. If boiler is operated under these conditions, the burner interior and ports must be cleaned and inspected daily to insure proper operation.

II. Unpack Boiler

CAUTION

Do not drop boiler. Do not bump boiler jacket against floor.

- Move boiler to approximate installed position.
- Remove all crate fasteners.
- Lift and remove outside container. Save two of the wooden slats from the container sleeve for use in Steps E and F.
- Remove all boiler hold-down fasteners.

WARNING

Installation of this boiler should be undertaken only by trained and skilled personnel from a qualified service agency.

- Tilt the boiler to its front side or back side and slide a wooden slat under the three raised feet.
- Tilt the boiler in the opposite direction and slide another wooden slat under the three raised feet.
- Slide the boiler left or right off the skid using the two wooden slats as runners.
- Move boiler to its permanent location.

III. Venting / Air Intake Piping

WARNING

Do not use this boiler with galvanized, Type 304 or Type 316 stainless steel, non metallic or any other non AL29-4C® based vent systems.

Do not use a barometric damper or draffhood with this appliance.

Do not use vent dampers with this boiler.

Moisture and ice may form on surfaces around termination. To prevent deterioration, surfaces should be in good repair (sealed, painted, etc.).

This appliance needs fresh air for safe operation and must be installed so there are provisions for adequate combustion and ventilation air.

Do not reduce size of air intake pipe.

Read, understand and follow combustion air instruction restrictions contained in the Pre-Installation instructions of this manual.

Do not operate appliance where gasoline or other flammable vapors or liquids, or sources of hydrocarbons (i.e. bleaches, cleaners, chemicals, sprays, paint removers, fabric softeners, etc.) are used, stored and/or present in the air.

When installing vent pipe through chimney, no other appliance can be vented into the chimney.

Do not exceed maximum vent/air intake lengths. Refer to Table 4.

TABLE 1: AIR INTAKE / VENT SYSTEM OPTIONS

Option	Description	Additional Vent Kit Required	Part Number	Installation Drawing and Specification (See Section)
1. Separate Horizontal	Direct Vent (sealed combustion) with both the vent pipe and air intake pipe terminating horizontally (through a sidewall) with individual penetrations for the vent and air intake piping and terminals.	No	See Table 2	D.
2. Separate Vertical	Direct Vent (sealed combustion) with both the vent pipe and air intake pipe terminating vertically (through the roof) with individual penetrations for the vent and air intake piping and terminals.	No	See Table 2	E.
3. Combination Horizontal	Direct Vent (sealed combustion) with the vent pipe and air intake pipe joining at a common terminal and terminating horizontally (through a sidewall up to 15" thick) with only one penetration.	Yes	3 - 6 Section (61106012)	F.
4. Combination Vertical	Direct Vent (sealed combustion) with the vent pipe and air intake pipe joining at a common terminal and terminating vertically (through the roof) with only one penetration.	Yes	3 - 4 Section (100222-01) 5 - 6 Section (100223-01)	G.
5. Indoor Air	Power Vent - Air used for combustion is provided from within the building.	No	-----	H.
6. Optional Separate Horizontal	Direct Vent (sealed combustion) with both the vent pipe and air intake pipe terminating horizontally (through a sidewall) with individual penetrations for the vent and air intake piping and terminals.	No	See Table 2	I.

TABLE 2: VENT SYSTEM COMPONENTS INCLUDED WITH BOILER

Vent System Components	Part Number
Gasketed Vent Terminal 3" Horizontal (SCG-3 thru SCG-7)	8110701
Gasketed Vent Terminal 4" Horizontal (SCG-8 & SCG 9)	8110702
Disc Air Intake - 3" (SCG-3 & SCG-4)	6116045
Disc Air Intake - 4" (SCG-5 & SCG-6)	6116044
Air Intake - 5" (SCG-7 thru SCG-9)	6116063

TABLE 3: VENT SYSTEM AND AIR INTAKE SYSTEM COMPONENTS

Vent System Component	Part Number	Equivalent Feet of Pipe
3" Dia. Pipe x 1 Ft	8116296U	1
4" Dia. Pipe x 1 Ft	100176-01	
3" Dia. Pipe x 3 Ft	8116298U	3
4" Dia. Pipe x 3 Ft	100177-01	
3" Dia. Pipe x 5 Ft	8116300U	5
4" Dia. Pipe x 5 Ft	100178-01	
3" Dia. Pipe x Adjustable	8116319U	Equal to Installed Length (1.06 TO 1.64)
4" Dia. Pipe x Adjustable	100179-01	
3" Dia. 90° Elbow	8116294U	5
4" Dia. 90° Elbow	100180-01	
3" Dia. 45° Elbow	8116292U	5
4" Dia. 45° Elbow	100181-01	
3" Dia. Horizontal Drain Tee	8116302U	2
4" Dia. Horizontal Drain Tee	100182-01	
3" Dia. Vertical Drain Tee	8116304U	7½
4" Dia. Vertical Drain Tee	100183-01	
3" Single Wall Thimble	8116116	---
4" Single Wall Thimble	100184-01	
3" Double Wall Thimble	8116115	---
4" Double Wall Thimble	100185-01	

Intake System Components (Parts by Others)	Equivalent Feet of Pipe *
3", 4", or 5" ID Pipe x 1 Ft	1
3", 4", or 5" ID Pipe x 2 Ft	2
3", 4", or 5" ID Pipe x 4 Ft	4
3", 4", or 5" ID Pipe x 5 Ft	5
3", or 4" 90° Elbow	5
3", or 4" 45° Elbow	5
5" 90° Elbow	6
5" 45° Elbow	6

* Equivalent Feet of Pipe Based on Standard 4" Smoke Pipe Design

TABLE 4: VENT/AIR INTAKE LENGTH

Model	3" Air Intake Pipe (Equiv. Ft.)		4" Air Intake Pipe (Equiv. Ft.)		5" Air Intake Pipe (Equiv. Ft.)		3" Vent Pipe (Equiv. Ft.)		4" Vent Pipe (Equiv. Ft.)	
	Min.	Max.	Min.	Max.	Min.	Max.	Min.	Max.	Min.	Max.
SCG-3 & SCG-4	8	50	---	---	---	---	8	50	---	---
SCG-5 & SCG-6	---	---	8	50	---	---	8	50	---	---
SCG-7	---	---	---	---	8	50	8	50	---	---
SCG-8 & SCG-9	---	---	---	---	8	40	---	---	8	40

A. Vent Guidelines Due to Removal of an Existing Boiler

For installations not involving the replacement of an existing boiler, proceed to Step B.

When an existing boiler is removed from a common venting system, the common venting system is likely to be too large for proper venting of the remaining appliances. At the time of removal of an existing boiler, the following steps shall be followed with each appliance remaining connected to the common venting system placed in operation, while the other appliances remaining connected to the common venting system are not in operation:

1. Seal any unused openings in the common venting system.
2. Visually inspect the venting system for proper size and horizontal pitch and determine there is no blockage or restriction, leakage, corrosion, and other deficiencies which could cause an unsafe condition.
3. Insofar as is practical, close all building doors and windows and all doors between the space in which the appliances remaining connected to the common venting system are located and other spaces of the building. Turn on clothes dryers and any appliance not connected to the common venting system. Turn on any exhaust fans, such as range-hoods and bathroom exhausts, so they will operate at maximum speed. Do not operate a summer exhaust fan. Close fireplace dampers.
4. Place in operation the appliance being inspected. Follow the Lighting (or Operating) Instructions. Adjust thermostat so appliance will operate continuously.
5. Test for spillage at the draft hood relief opening after five (5) minutes of main burner operation. Use the flame of a match or candle, or smoke from a cigarette, cigar or pipe.
6. After it has been determined that each appliance remaining connected to the common venting system properly vents when tested as outlined above, return doors, windows, exhaust fans, fireplace dampers and any other gas burning appliance to their previous conditions of use.
7. Any improper operation of the common venting system should be corrected so the installation conforms with the *National Fuel Gas Code*, NFPA 54/ANSI Z223.1. When resizing any portion of the common venting system, the common venting system should be resized to approach the minimum size as determined using the appropriate tables in Part II in the *National Fuel Gas Code*, NFPA 54/ANSI Z223.1.

B. General Guidelines

1. Vent system installation must be in accordance with *National Fuel Gas Code*, NFPA 54/ANSI Z221.3 or applicable provisions of local building codes. Contact local building or fire officials about restrictions and installation inspection in your area.
2. The SCG is designed to be installed as either a Direct Vent boiler or Power Vent boiler. In the Direct Vent configuration all of the air for combustion is supplied directly to the burner enclosure from outdoors and flue gases are vented directly outdoors (through wall or roof). In the Power Vent configuration, room air provides air for combustion and ventilation. Flue gases are still vented directly outdoors (through wall or roof). Note: Venting requirements change if indoor air is used.
3. Refer to the appropriate drawings in this section of this manual to determine the proper configuration of venting system. See Table 1.
4. This appliance requires a Special Gas Vent. The product is designed to use supplied AL 29-4C® Stainless Steel vent system components. The following manufacturers offer similar AL 29-4C® components and are approved for use with this product. Heat-Fab Inc. - Saf-T-Vent (800-772-0739); Flex-L International Inc. - Star-34 (800-561-1980); Z-Flex U. S., Inc. - Z-Vent (800-654-5600); and Protech Systems, Inc.- FasNSeal™ (800-766-3473) or equivalent. The use of these alternate manufacturer's venting systems will require adapters to connect to the supplied vent connector and vent terminal. These adapters are not supplied with this unit and should be obtained from the supplier of the alternate manufacturer's venting system. See Table 3 for complete list of U.S. Boiler Vent System Components.
5. Horizontal vent pipe must maintain a minimum ¼ inch per foot slope down towards boiler.
6. Use noncombustible ¾ inch pipe strap to support horizontal runs and maintain vent location and slope while preventing sags in pipe. Do not restrict thermal expansion or movement of vent system. Maximum support spacing is five (5) feet. Do not penetrate any part of the vent system with fasteners.
7. Vent length restrictions are based on equivalent length of vent/air pipe (total length of straight pipe plus equivalent length of fittings). Maximum vent/air lengths are listed in Table 4. Do not exceed maximum vent/air intake lengths. Table 3 lists equivalent lengths for fittings. Do not include vent/air terminals in equivalent feet calculations.
8. Provide and maintain vent pipe minimum clearances to combustible materials. Vent pipe minimum clearance to combustible material is four (4) inches when vent is installed in a fully enclosed (chase) application or three (3) inches when vent is installed

with at least one side open, similar to a joist bay application. Use double wall thimble [Part No. 8116115 (3"), 100185-01 (4")] when penetrating a combustible wall.

9. Do not install venting system components on the exterior of the building except as specifically required by these instructions. The vent termination location is restricted as follows:

a. Minimum twelve (12) inches above grade plus normally expected snow accumulation level, or seven (7) feet above grade if located adjacent to public walkway. Do not install over public walkway where local experience indicates appliance flue gas vapor or condensate creates a nuisance or hazard.

b. Minimum three (3) feet above any forced air inlet located within ten (10) feet.

c. Direct Vent - Minimum one (1) foot below, one (1) foot horizontally from, or one (1) foot above any door, window, or gravity air inlet.

Power Vent - Minimum four (4) feet below, four (4) feet horizontally from, or four (4) feet above any door, window, or gravity air inlet.

d. Minimum four (4) feet horizontally from electric meters, gas meters, regulators, and relief valves. This distance may be reduced if equipment is protected from damage due to condensation or vapor by enclosure, overhangs, etc.

e. Minimum twelve (12) inches from overhang or corner of building.

10. Enclose vent passing through occupied or unoccupied spaces above the boiler with material having a fire resistance rating of at least equal to the rating of the adjoining floor or ceiling. Maintain minimum clearances to combustible materials. See Figure 1.

Note: For one or two family dwellings, fire resistance rating requirement may not need to be met, but is recommended.

11. Plan venting system to avoid possible contact with plumbing or electrical wires. Start at vent connector on top of boiler and work towards vent terminal.
12. Once a vent pipe manufacturer and system is chosen never mix and match vent systems.
13. If a non-standard length pipe is required:

Gasketed Vent System: The use of the adjustable length pipe (P/N 8116319U) is recommended to complete a non-standard pipe length. This pipe requires a minimum installed length of 12¾ inch and can adjust across a 7 inch gap up to a maximum of 19¾ inch long. (Note for the adjustable pipe the installed length should be measured from the centerline of the bead on the male end of the first pipe to the end of the female pipe excluding the locking band of the second pipe with a single gasket.) Only in the event the adjustable length pipe is not sufficient a standard length pipe may be cut using the procedure outlined below for the Gasket-Less Vent System.

WARNING

Never exceed maximum installed length of 19¾ inches for adjustable length pipe. Risk of flue gas leakage is possible.

NOTICE

Cut must be square with pipe and filed or sanded smooth before joining. Carefully ensure roundness of cut pipe by hand with gloves before installing. Seal joint with RTV specified in this manual.

C. Install Vent Pipe, U.S. Boiler Gasketed Vent System.

1. Procedure for Joining U.S. Boiler Gasketed Vent Pipe and Fittings. See Figure 3.

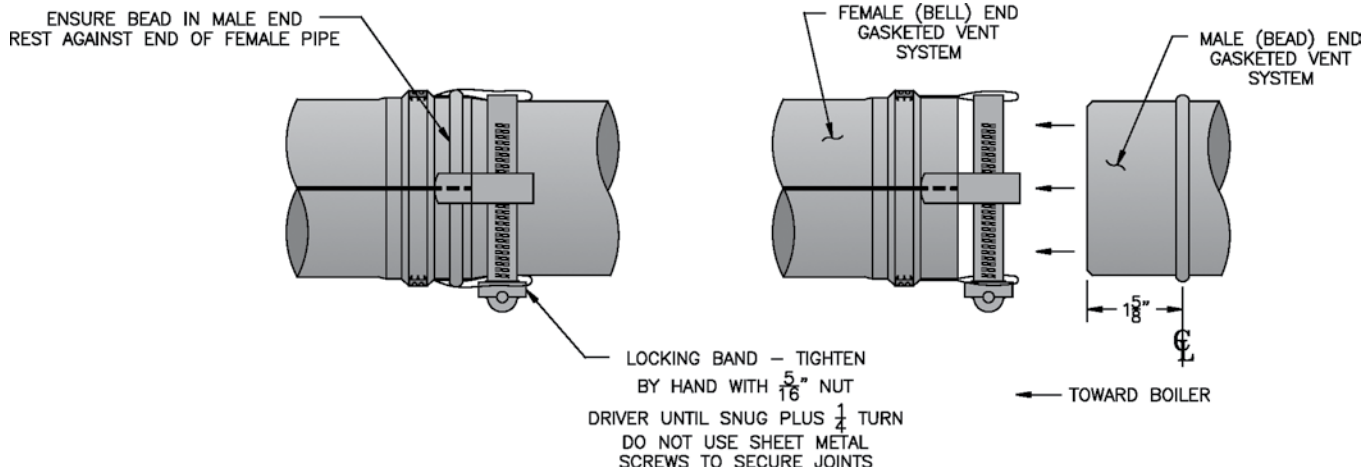

Figure 3: U.S. Boiler Gasketed Vent Joint Detail

- a. Wipe the male end of each joint using an alcohol pad to remove any dirt and grease.
- b. Align weld seams in pipes and use a slight twisting motion to FULLY insert male end into female end of joint. Ensure bead in male end of pipe is below locking band and rest against the end of the female pipe. Verify the factory-installed gasket is not dislodged or cut.
- c. Tighten locking band by HAND with a 5/16" nut driver until snug plus ¼ turn. DO NOT SECURE JOINTS WITH SHEET METAL SCREWS OR POP RIVETS. DO NOT PUNCTURE THE VENT SYSTEM!
- d. Once the installation is complete, operate appliance and inspect all joints to ensure that flue gases and/or liquid condensate will not escape.

D. Separate Horizontal Venting System. See Figures 4A, 4B, 5A and 5B. See Figure 43 on Page 73 for Blower Vent Connector Assembly.

Vent Piping –

1. This boiler is supplied with components as standard equipment for installation of the separate horizontal venting system.
2. Do not exceed maximum vent/air intake lengths. Refer to Table 4.
3. Recommended horizontal installation consists of vent being sloped down ¼ inch per foot away from boiler. See Figure 4A. See Figure 48 for an alternate horizontal installation.
4. Use appropriate designed thimbles when passing through combustible walls (thimble use optional for noncombustible walls). Insert thimble through wall from outside. Secure outside flange to wall with nails or screws, and seal ID, OD and vent holes with sealant material. Install inside flange to inside wall, secure with nails or screws, and seal with sealant material.
5. For noncombustible wall application when thimble is not used, size opening such that bell with locking band attached cannot pass through.
6. Join vent terminal to vent pipe. See Figures 5A and 5B.
7. Insert vent pipe through thimble/opening from outside and join to vent system. Apply sealant between vent pipe and opening/thimble to provide weathertight seal.

Air Intake piping - See Figures 4A, 4B, 5A and 5B.

8. Locate air intake termination on the same wall as the vent termination if possible, to prevent nuisance boiler shutdowns. However, boiler may be installed with vertical venting and sidewall combustion air inlet or visa versa, if installation conditions do not allow alternate arrangement.
9. Do not exceed air intake length. See Table 4.
10. Use single wall metal or PVC pipe.
 - a. Air intake pipe diameter is based on boiler size.
 - SCG-3 & SCG-4 uses 3 inch diameter piping.
 - SCG-5 & SCG-6 uses 4 inch diameter piping.
 - SCG-7 thru SCG-9 uses 5 inch diameter piping.
11. Air intake termination must be located:
 - Horizontal - At least twelve (12) inches above grade plus the expected snow accumulation.
12. Start at collar on boiler jacket and work towards the air intake terminal.
13. Maintain minimum of ¼ inch per foot slope on horizontal runs. Slope towards air inlet terminal when possible. If not, slope towards boiler.
14. The air intake pipe must be adequately supported with straps or supports no less than five (5) feet apart on horizontal runs. The complete air intake piping system must be rigid and able to withstand minor impacts without collapse.
15. Inlet air pipe penetration:
 - Horizontal - Size wall penetration to allow easy insertion of air inlet piping. Seal around pipe with sealant to form weathertight exterior joint.
16. Seal all joints airtight, using silicone caulk or self-adhesive aluminum tape.
17. Install Air Intake Terminal:
 - Horizontal - Remove four (4) screws from cover plate and remove cover plate from terminal. Insert intake piping into intake terminal collar. Secure terminal to intake piping and seal joint with silicone caulk or self-adhesive aluminum tape. Apply continuous bead of silicone caulk around the back of the intake terminal, approximately ¼ inch from its edge. Push inlet terminal inward until terminal's back flange is against the wall surface. Secure the terminal with noncorrosive fasteners (stainless steel, brass or aluminum) to the wall. Reinstall the cover plate with four (4) screws. Apply a bead of silicone caulk to perimeter of intake terminal's back flange to provide a weathertight seal.

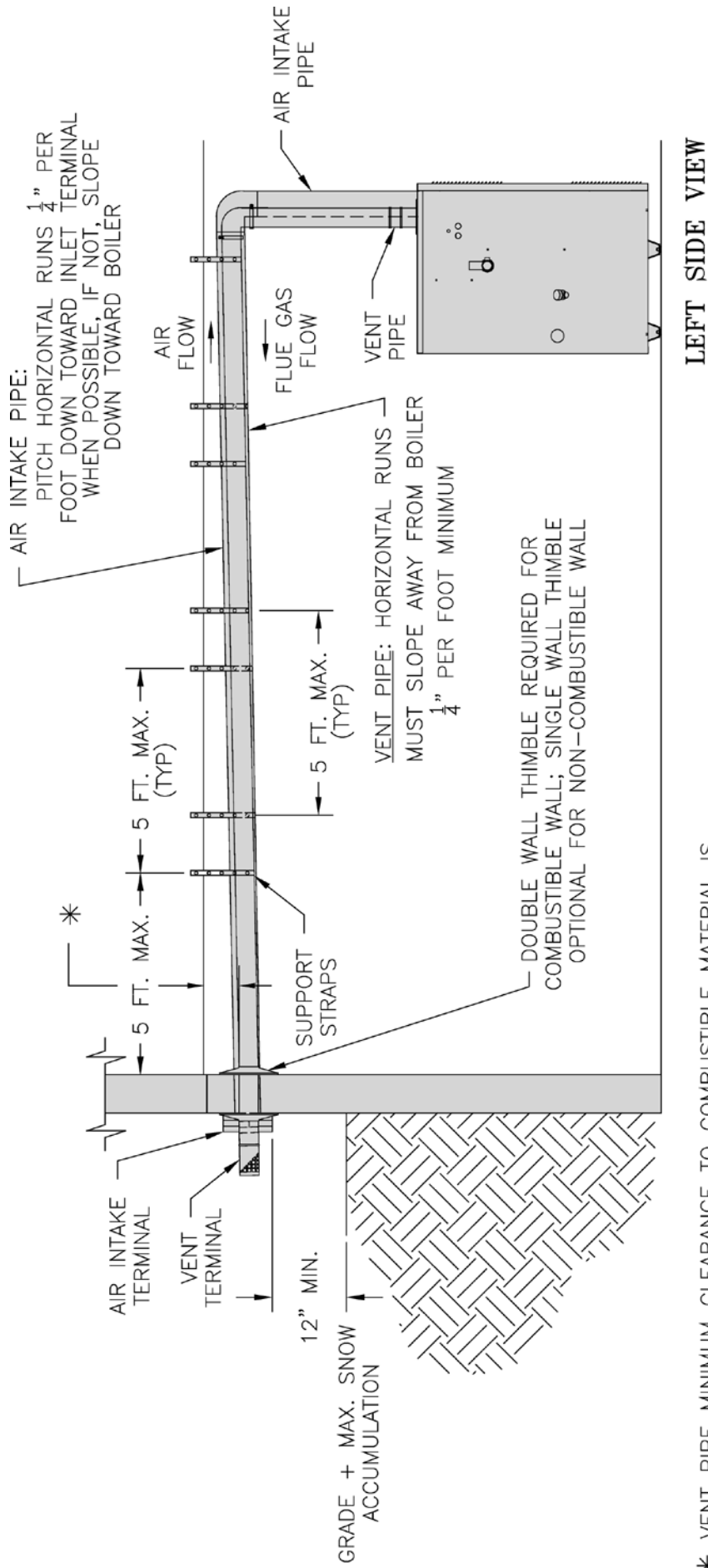

* VENT PIPE MINIMUM CLEARANCE TO COMBUSTIBLE MATERIAL IS FOUR (4) INCHES WHEN VENT IS INSTALLED IN A FULLY ENCLOSED (CHASE) APPLICATION OR THREE (3) INCHES WHEN VENT IS INSTALLED WITH AT LEAST ONE SIDE OPEN, SIMILAR TO A JOIST BAY APPLICATION.

Figure 4A: Recommended Separate Horizontal – Vent/Air Intake Installation

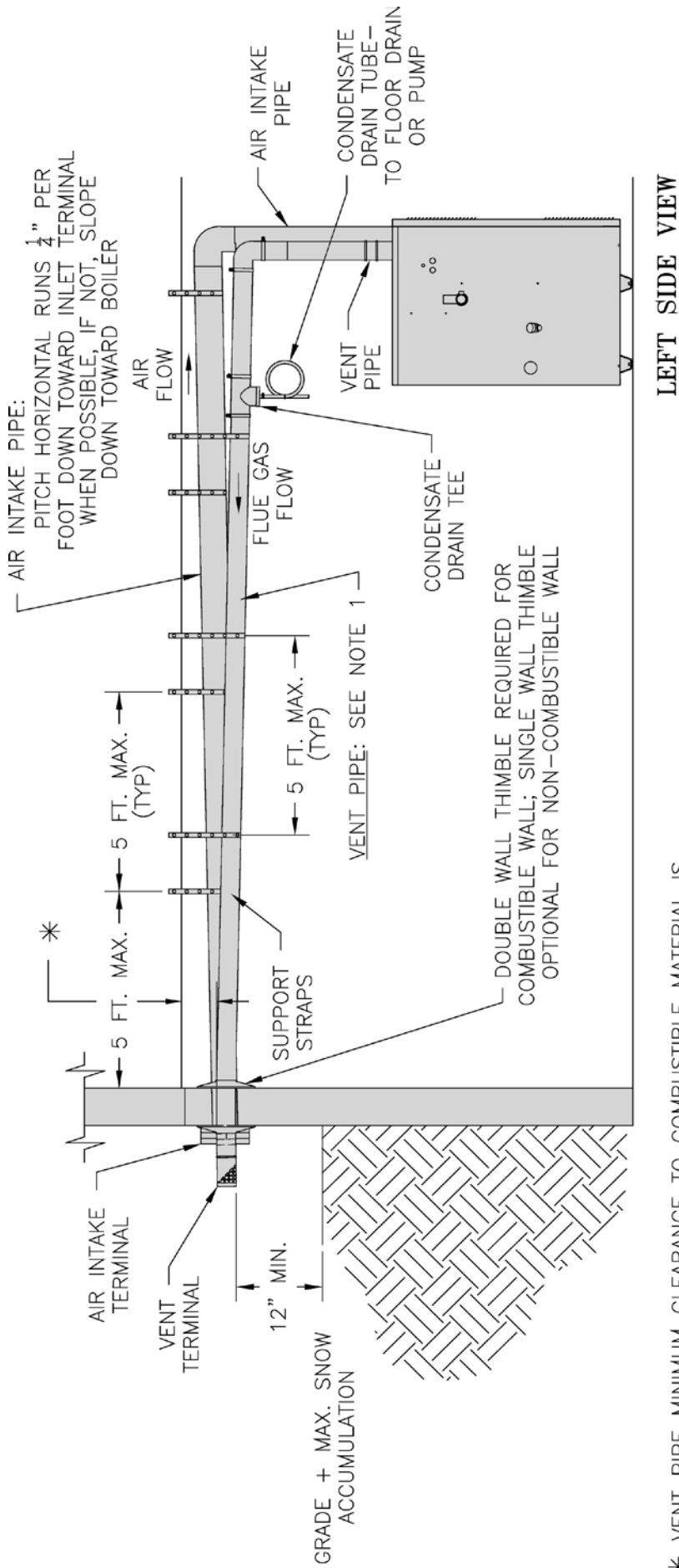

* VENT PIPE MINIMUM CLEARANCE TO COMBUSTIBLE MATERIAL IS FOUR (4) INCHES WHEN VENT IS INSTALLED IN A FULLY ENCLOSED (CHASE) APPLICATION OR THREE (3) INCHES WHEN VENT IS INSTALLED WITH AT LEAST ONE SIDE OPEN, SIMILAR TO A JOIST BAY APPLICATION.

NOTE 1:

HORIZONTAL RUNS MUST SLOPE TOWARD THE BOILER $\frac{1}{4}$ " PER FOOT MIN. WHEN USING A CONDENSATE TEE.

Figure 4B: Alternate Separate Horizontal – Vent/Air Intake Installation

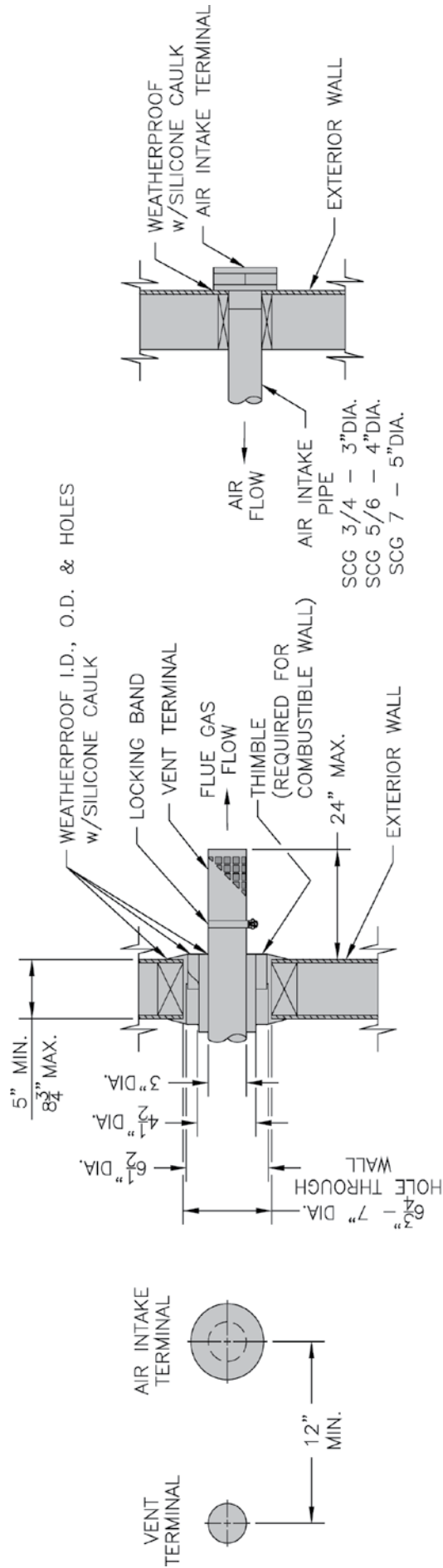

HORIZONTAL

VENT TERMINAL

AIR INTAKE TERMINAL

Figure 5A: Separate Horizontal – Vent/Air Intake Terminal Configuration (SCG-3 thru 7)

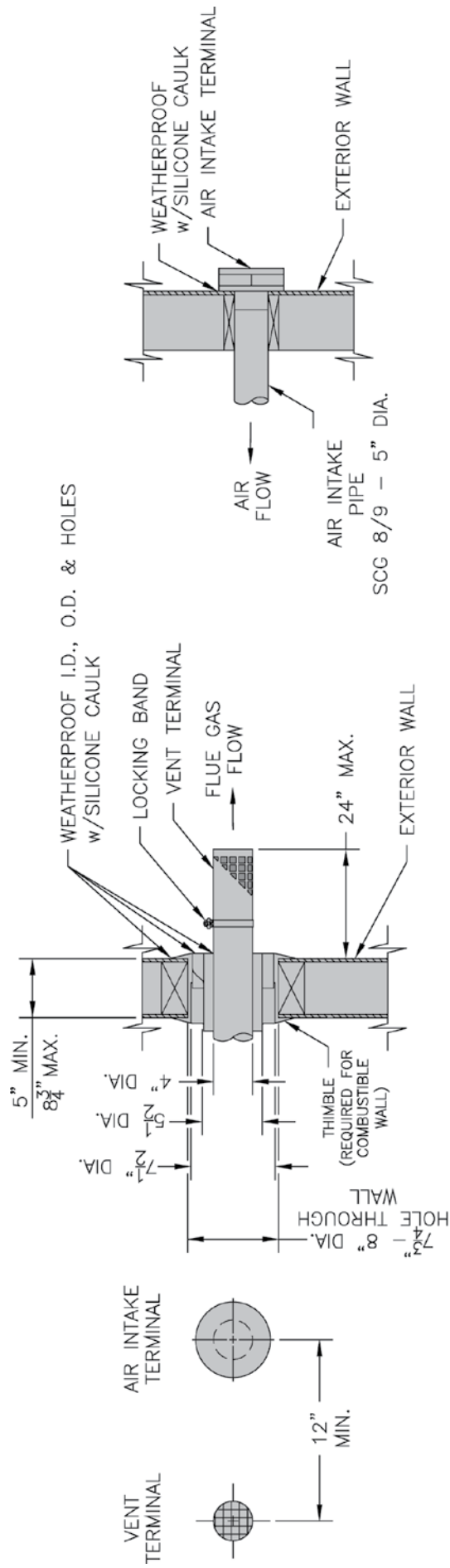

HORIZONTAL

VENT TERMINAL

AIR INTAKE TERMINAL

Figure 5B: Separate Horizontal – Vent/Air Intake Terminal Configuration (SCG-8 and 9)

E. Separate Vertical Venting System - See Figures 6, 7, 8A, 8B and 9.

NOTICE

Roof penetrations require the use of roof flashing and storm collar - not supplied with boiler.

Vertical Venting –

1. See Figure 43 on Page 73 for Blower Vent Connector Assembly. Do not exceed maximum vent lengths. Refer to Table 4.
2. Installation of a vertical vent drain tee 8116304U is required on all vertical vent applications. See Figures 6 and 7. Attach vertical vent drain tee directly to elbow or horizontal pipe from an elbow immediately after vent connector.
3. Slope horizontal runs minimum ¼ inch per foot. Slope towards vertical vent drain tee. Position weld seams in vent pipes, in all horizontal runs, at the top to avoid condensate from lying on the seams.
4. Install fire stops where vent passes through floors, ceilings or framed walls. The fire stop must close the opening between the vent pipe and the structure.
5. Whenever possible, install vent straight through the roof. Refer to Figure 7 if offset is necessary. Maintain minimum clearance to combustible materials.
6. Install Vent Terminal.
 - a. Size roof opening to maintain minimum clearance from combustible materials.
 - b. Extend vent pipe to maintain minimum vertical and horizontal distance of twelve (12) inches from roof surface. Allow additional vertical distance for expected snow accumulation. Provide brace as required. Refer to Figures 8A and 8B.

NOTICE

Vertical venting requires the use of roof flashing and a storm collar to prevent moisture from entering the structure.

- c. Install storm collar on vent pipe immediately above flashing. Apply Dow Corning Silastic 732 RTV Sealant between vent pipe and storm collar to provide weathertight seal.
- d. Attach vent terminal.

Vertical Air Intake Piping –

7. Do not exceed maximum air intake length. Refer to Table 4.

8. Locate air intake termination on the same roof location as the vent termination if possible, to prevent nuisance boiler shutdowns. However, boiler may be installed with vertical venting and sidewall combustion air inlet or visa versa, if installation conditions do not allow alternate arrangement.
9. Use single wall metal pipe or PVC and fittings available at most heating distributors.
 - a. Air intake pipe diameter is based on boiler size.
SCG-3 & SCG-4 uses 3 inch diameter piping.
SCG-5 & SCG-6 uses 4 inch diameter piping.
SCG-7 thru SCG-9 uses 5 inch diameter piping.
10. Air intake termination must be located:
Vertical - At least twelve (12) inches above the roof surface plus the expected snow accumulation.
11. Start at collar on burner enclosure (inside boiler jacket) and work towards the air intake terminal.
12. Maintain minimum of ¼ inch per foot slope on horizontal runs. Slope down towards boiler.
13. The air intake pipe must be adequately supported with straps or supports no less than five (5) feet apart on horizontal runs. The complete air intake piping system must be rigid and able to withstand minor impacts without collapse.
14. Inlet air pipe penetration:
Vertical - Size roof opening to allow easy insertion of inlet piping and allow proper installation of flashing and storm collar.
 - a. Use appropriately designed vent flashing when passing through roofs. Follow flashing manufacturers' instructions for installation procedures. Flashing manufacturers are Air-Jet, American Metal Products, Metal Fab, and Simpson Dura-Vent.
 - b. Extend air intake pipe to maintain minimum vertical and horizontal distance of twelve (12) inches from roof surface. Allow additional vertical distance for expected snow accumulation. Provide brace as required. Refer to Figures 8A and 8B.
 - c. Vertical air intake requires flashing and a storm collar to prevent moisture from entering the structure.

- d. Install storm collar on air intake pipe immediately above flashing. Apply Dow Corning Silastic 732 RTV Sealant between air intake pipe and storm collar to provide weathertight seal.
 - e. All exposed air intake piping must be constructed of corrosion resistant material such as aluminum, stainless steel or PVC.
- 15. Seal all joints airtight, using silicone caulk or self-adhesive aluminum tape.
 - 16. Install Air Intake Terminal:
 - Vertical - Insert intake piping into intake terminal collar. Secure terminal to intake piping and seal joint with silicone caulk.

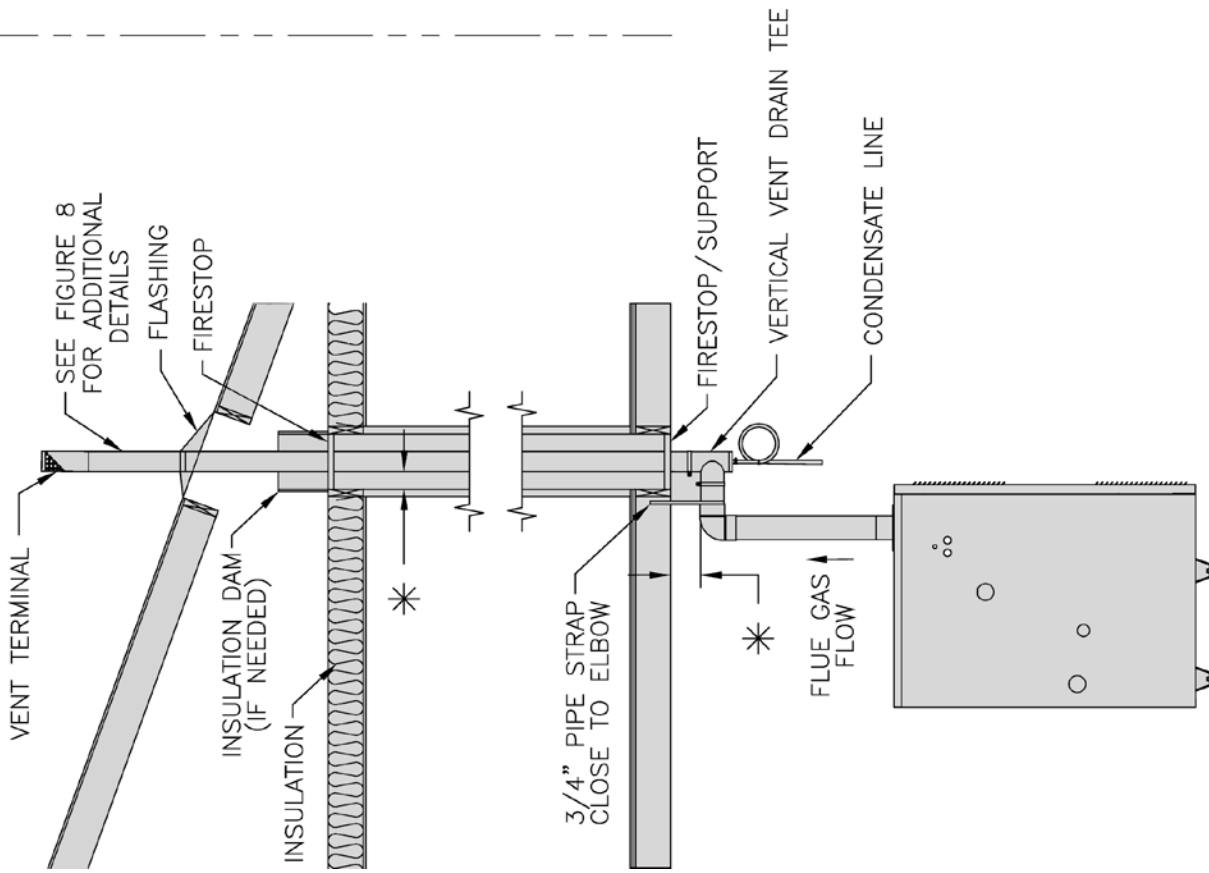

LEFT SIDE VIEW

Figure 6: Vertical Vent Installation

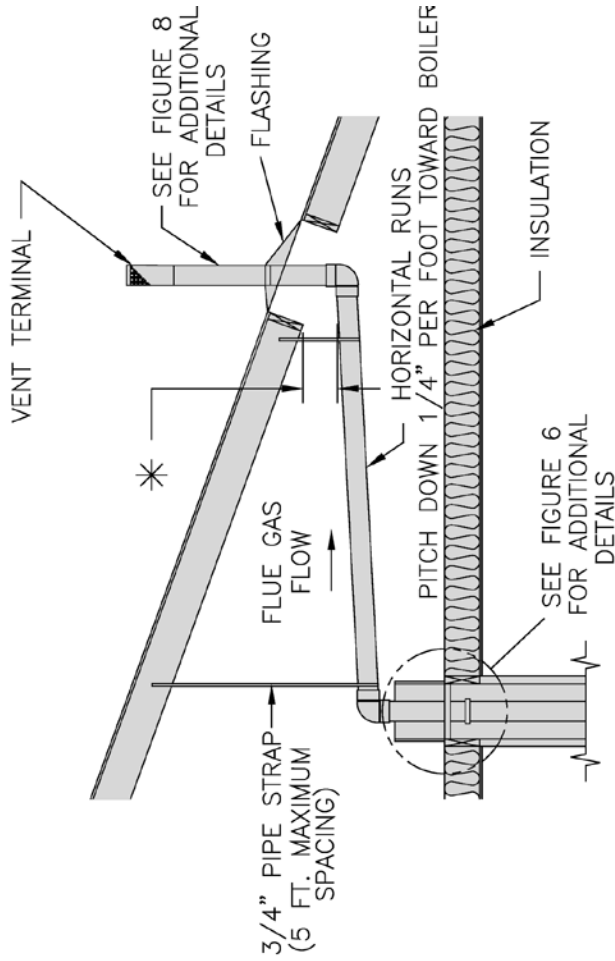

* VENT PIPE MINIMUM CLEARANCE TO COMBUSTIBLE MATERIAL IS FOUR (4) INCHES WHEN VENT IS INSTALLED IN A FULLY ENCLOSED (CHASE) APPLICATION OR THREE (3) INCHES WHEN VENT IS INSTALLED WITH AT LEAST ONE SIDE OPEN, SIMILAR TO A JOIST BAY APPLICATION.

Figure 7: Attic Offset

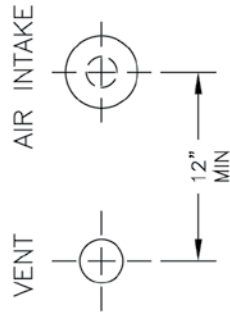
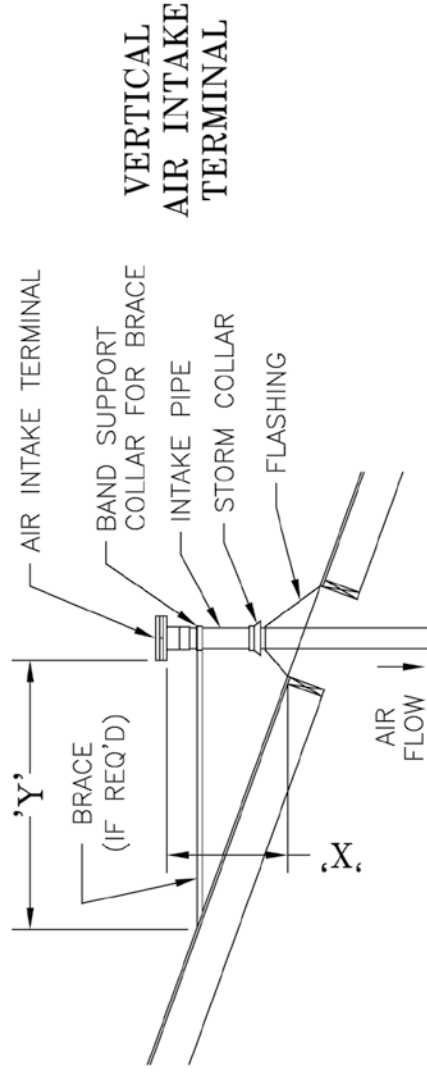
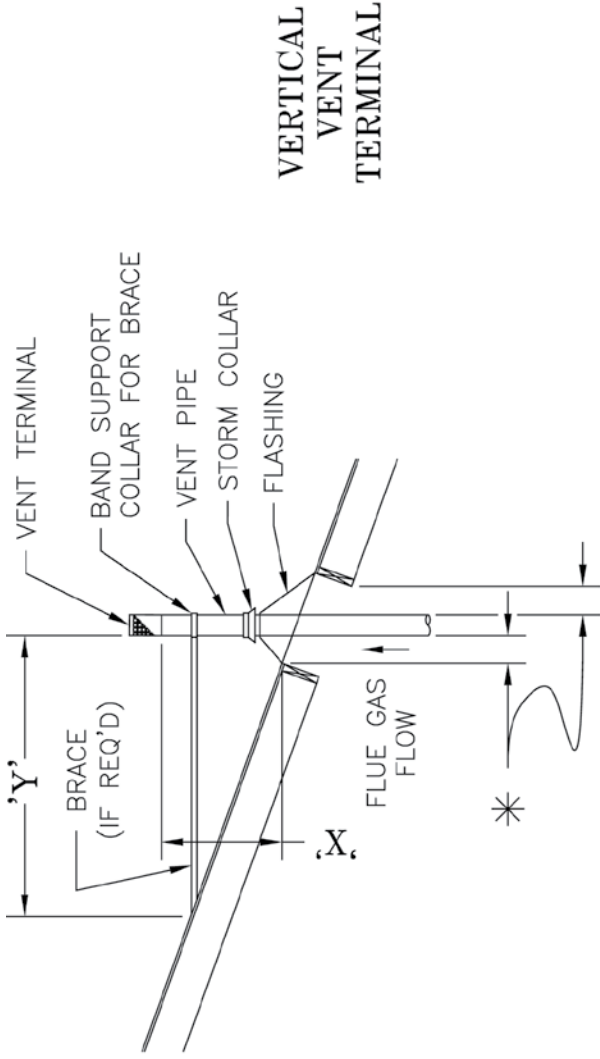

VERTICAL

VENT/AIR INTAKE
TERMINAL RELATIONSHIP
(AIR INTAKE TERMINAL
MAY BE INSTALLED
ON RIGHT OR LEFT SIDE)

* VENT PIPE MINIMUM CLEARANCE TO COMBUSTIBLE MATERIAL IS FOUR (4) INCHES WHEN VENT IS INSTALLED IN A FULLY ENCLOSED (CHASE) APPLICATION OR THREE (3) INCHES WHEN VENT IS INSTALLED WITH AT LEAST ONE SIDE OPEN, SIMILAR TO A JOIST BAY APPLICATION.

Figure 8A: Vertical Vent/Air Termination (3" Vent Terminal)

Extend Vent/Air Intake Piping to maintain minimum vertical ("X") and minimum horizontal ("Y") distance of twelve (12) inches from roof surface. Allow additional vertical ("X") distance for expected snow accumulation.

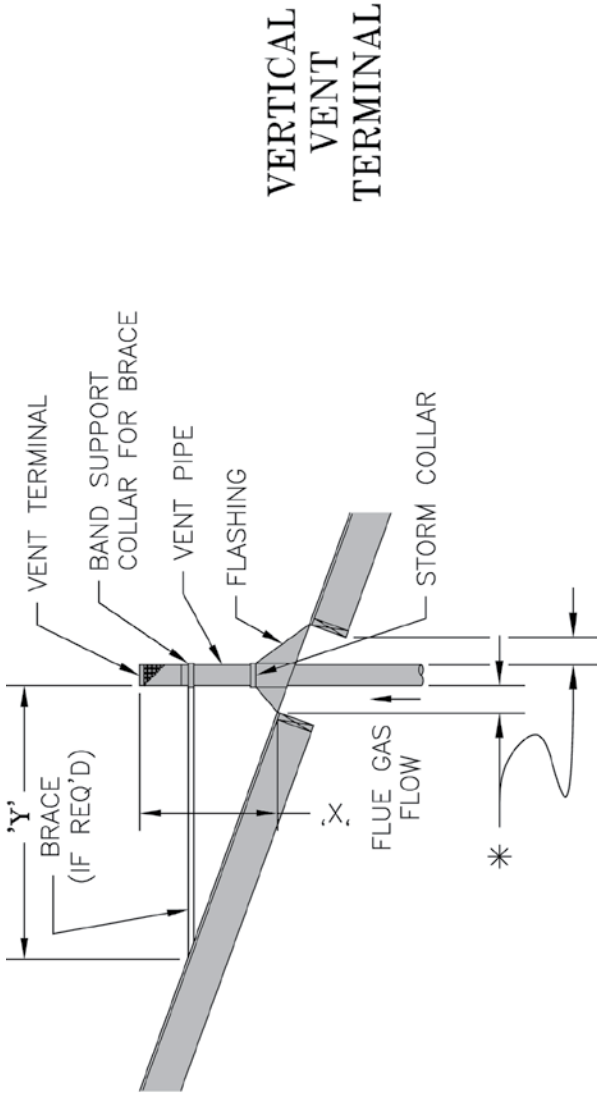

**VERTICAL
VENT
TERMINAL**

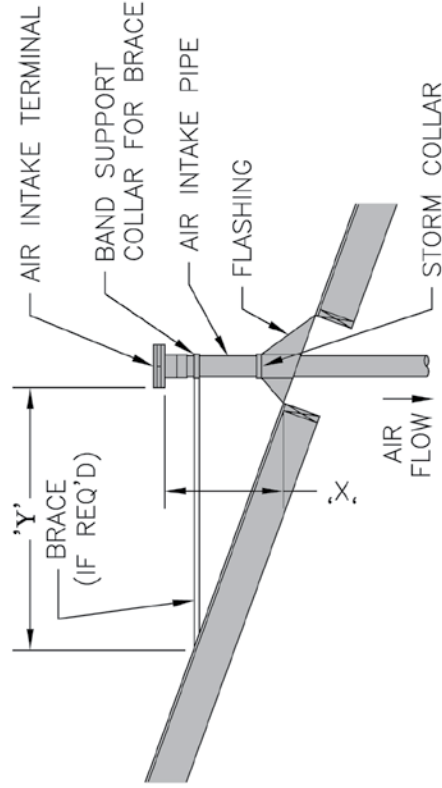

**VERTICAL
AIR INTAKE
TERMINAL**

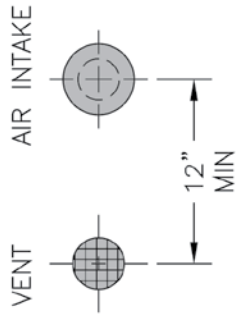

VERTICAL

VENT/AIR INTAKE
TERMINAL RELATIONSHIP
(AIR INTAKE TERMINAL
MAY BE INSTALLED
ON RIGHT OR LEFT SIDE)

* VENT PIPE MINIMUM CLEARANCE TO COMBUSTIBLE MATERIAL IS FOUR (4) INCHES WHEN VENT IS INSTALLED IN A FULLY ENCLOSED (CHASE) APPLICATION OR THREE (3) INCHES WHEN VENT IS INSTALLED WITH AT LEAST ONE SIDE OPEN, SIMILAR TO A JOIST BAY APPLICATION.

Figure 8B: Vertical Vent/Air Termination (4" Vent Terminal)

Extend Vent/Air Intake Piping to maintain minimum vertical ("Y") and minimum horizontal ("X") distance of twelve (12) inches from roof surface. Allow additional vertical ("X") distance for expected snow accumulation.

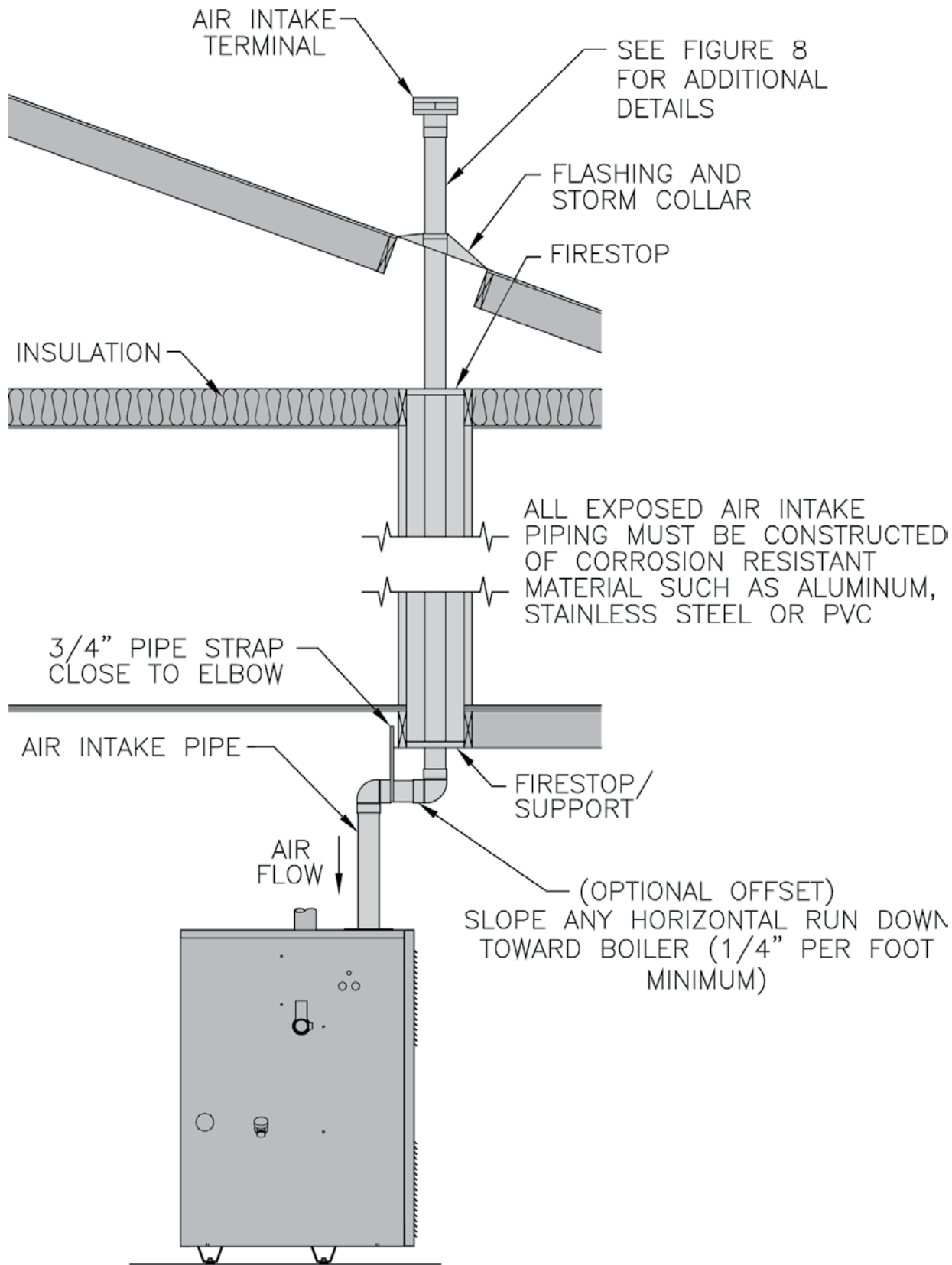

LEFT SIDE VIEW

Figure 9: Vertical Air Intake Piping

F. Combination Horizontal Venting System –SCG-3 Through SCG-6 ONLY – See Figures 10 and 11.

NOTICE

This vent system requires components not supplied with the boiler.

1. Do not exceed maximum vent/air intake lengths. Refer to Table 4.

2. Install Combination Vent/Air Terminal. See Figure 11.
- After determining the location with reference to Section B - General Venting Guidelines, cut a 6-1/8 inch square opening in the wall for the air box sub-assembly which is 6 inch square.
 - Remove and save shipping screw from end panel with collar and vent pipe assembly. This will be reinstalled in a later step.

Vent Carton Part Number 61106012 (Includes Items Below)		
Description		Component Part Number
A	Air Box Sub-Assembly (6" square x 2' long)	61106011
B	Exterior Wall Cover (10" square)	71106016
C	4" x 3" Vent Pipe Reducer	8116239
D	Plate-Seal Exterior Cover (2)	71106017
E	#8 x 1/2" Stainless Steel Sheet Metal Screw (19)	80860047
F	#10 - 32 x 1/4" Stainless Steel Machine Screw (8)	80860842
G	#10 - 32 x 1/2" Aluminum Spacer (4)	80861617

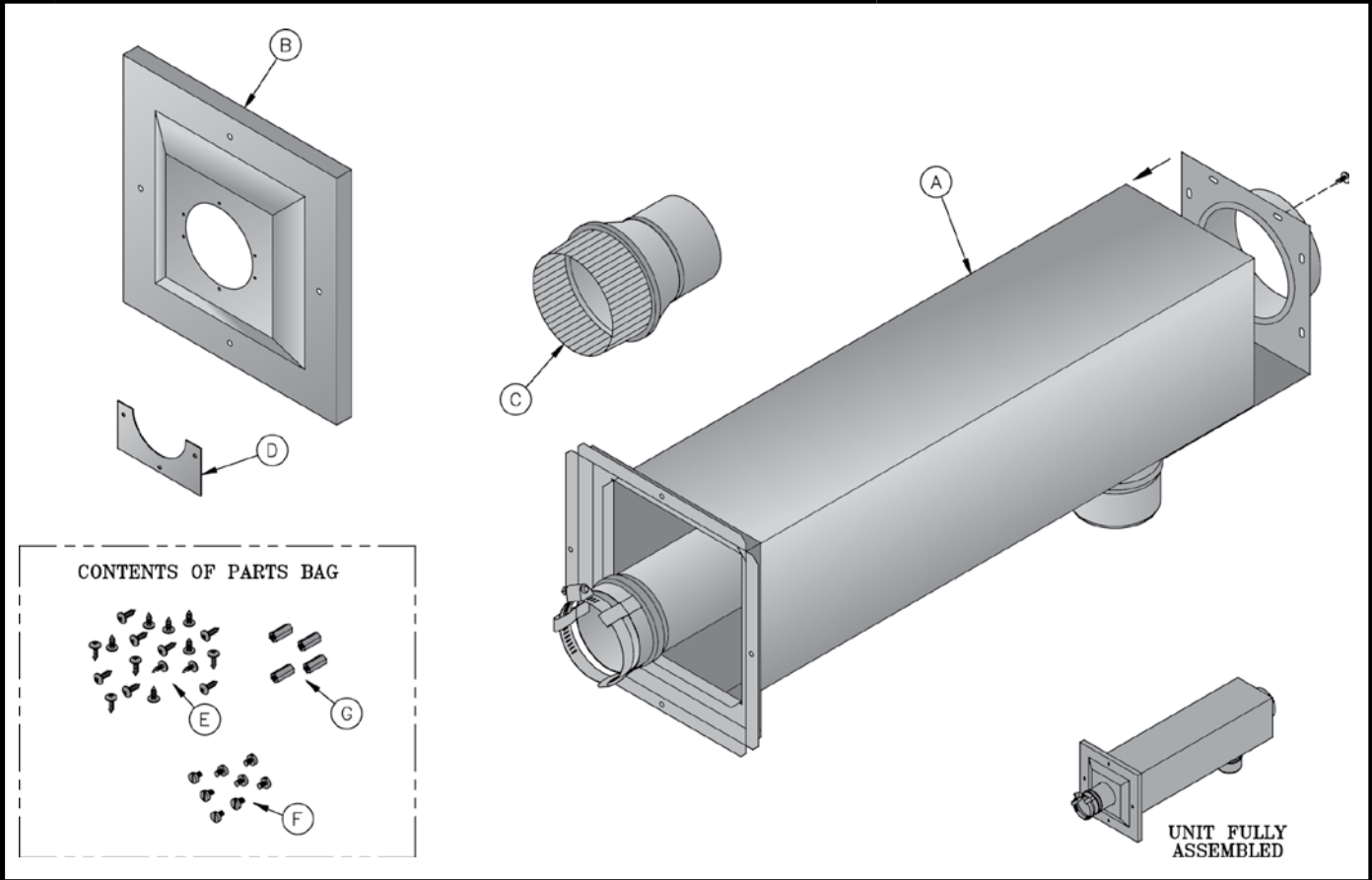

COMBINATION HORIZONTAL VENT SYSTEM COMPONENTS

- c. From exterior of building, insert air box sub-assembly into square opening. Push air box inward until wall flange is against wall, check for level and mark the location of the four (4) securing holes on the exterior wall. Remove air box from wall.
- d. Drill four (4) pilot holes, properly sized for the non-corrosive fasteners (stainless steel, brass, or aluminum) to be used to secure the wall flange to the exterior wall. (Securing screws not supplied with kit.)
- e. Attach four (4) 1/2 inch long threaded aluminum spacers to the outer flanges of the exterior wall flange with four (4) number 10 - 32 x 1/4 inch stainless steel machine screws provided. (See Figure 11.)
- f. Apply a 1/4 inch thick continuous bead of silicone caulk to perimeter of exterior wall flange's back surface to provide a weathertight seal.
- g. Reinstall air box sub-assembly into opening in exterior wall and secure to wall.

WARNING

Non-corrosive fasteners must be used.

- h. Apply a bead of silicone caulk to perimeter of wall flange, where the wall and flange join. Use a tool or your finger and apply pressure while smoothing caulking to provide a weathertight seal.
- i. From interior of building, insert end panel with collar and vent pipe assembly into open end of air box sub-assembly. (See Figure 11.)
- j. Secure end panel to air box sub-assembly with shipping screw and thirteen (13) number 8 sheet metal screws provided.
- k. From exterior of building, position 10 inch square exterior wall cover over exterior wall flange. Insert 3 inch diameter vent pipe into center opening in terminal cover. Align four (4) holes on cover with 1/2 inch long threaded spacers on wall flange. Secure terminal cover with four (4) number 10 - 32 x 1/4 inch stainless steel machine screws provided.
- l. Apply a bead of silicone caulk to perimeter of plate-seal and around pipe. Secure plate-seal to exterior cover with six (6) #8 stainless steel sheet metal screws provided. Smooth caulk around plate-seal and pipe to provide weathertight seal.
- m. Install Vent Terminal supplied with boiler to vent pipe penetrating through terminal cover. Join terminal and pipe with locking band and seal with RTV (see Figure 3).

3. Install Vent Piping. See Figures 10 and 11.
 - a. Start at vent connector on boiler, see Figure 43 on Page 73, and work towards combination vent/air terminal.
 - b. Installation of a vertical vent tee 8116304U is required on all vertical vent applications. See Figures 12 and 13. Attach vertical vent drain tee directly to elbow or horizontal pipe from an elbow immediately after vent connector.
 - c. Slope horizontal runs minimum 1/4 inch per foot. Slope towards vertical vent drain tee. Position weld seams in vent pipes, in all horizontal runs, at the top to avoid condensate from lying on the seams.
 - d. Use 3/4 inch pipe strap to support horizontal runs and maintain vent location and slope. Maximum support spacing is five (5) feet.
 - e. Install vent piping to connect vent connector on boiler and combination vent/air terminal. Reference Section B - General Venting Guidelines for proper procedure for joining pipe and fittings.
 - f. Connect vent piping to combination vent/air terminal. See Figure 10.
4. Install Air Intake Piping. See Figures 10 and 11.
 - a. Do not exceed air intake length. See Table 4.
 - b. Use single wall metal pipe or PVC and fittings available at most heating distributors.
 - c. Air intake pipe diameter is based on boiler size. SCG-3 & SCG-4 uses 3 inch diameter piping. SCG-5 & SCG-6 uses 4 inch diameter piping. SCG-7 thru SCG-9 uses 5 inch diameter piping.
 - d. Start at collar on burner enclosure (inside boiler jacket) and work towards the combination vent/air terminal.
 - e. Maintain minimum of 1/4 inch per foot slope on horizontal runs. Slope down towards boiler.
 - f. The air intake pipe must be adequately supported with straps or supports no less than five (5) feet apart on horizontal runs. The complete air intake piping system must be rigid and able to withstand minor impacts without collapse.
 - g. Connect Air Intake Piping to Combination Vent/Air Terminal. See Figure 10.

NOTE: When installing 3 inch diameter air intake piping for a SCG-3 or SCG-4 application, the use of a 4 inch x 3 inch reducer will be required to connect air intake piping to combination vent/air terminal. (Reducer included with combination horizontal venting kit).

 - h. Seal all joints airtight, using silicone caulk or self-adhesive aluminum tape.

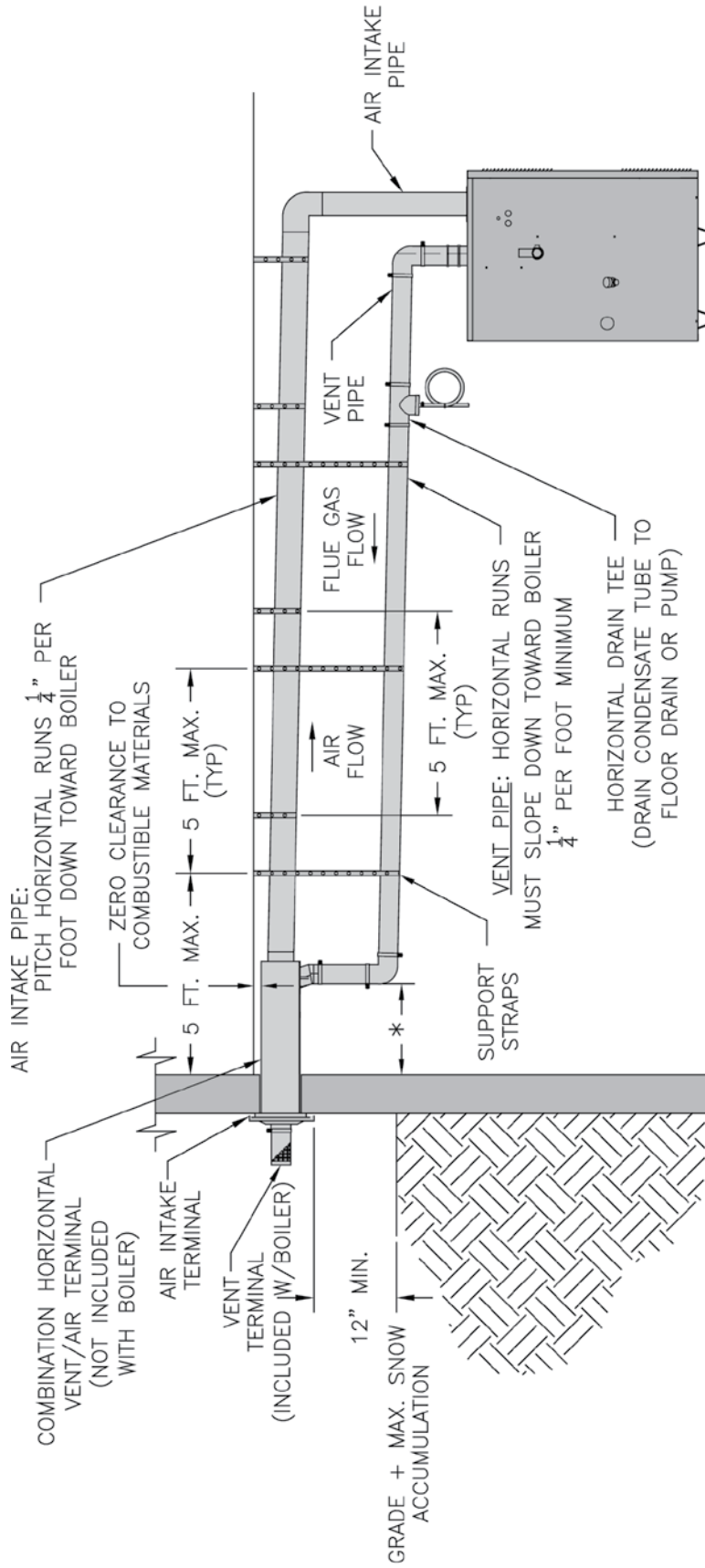

LEFT SIDE VIEW

* VENT PIPE MINIMUM CLEARANCE TO COMBUSTIBLE MATERIAL IS FOUR (4) INCHES WHEN VENT IS INSTALLED IN A FULLY ENCLOSED (CHASE) APPLICATION OR THREE (3) INCHES WHEN VENT IS INSTALLED WITH AT LEAST ONE SIDE OPEN, SIMILAR TO A JOIST BAY APPLICATION.

Figure 10: Combination Horizontal – Vent/Air Installation (SCG-3 thru 6)

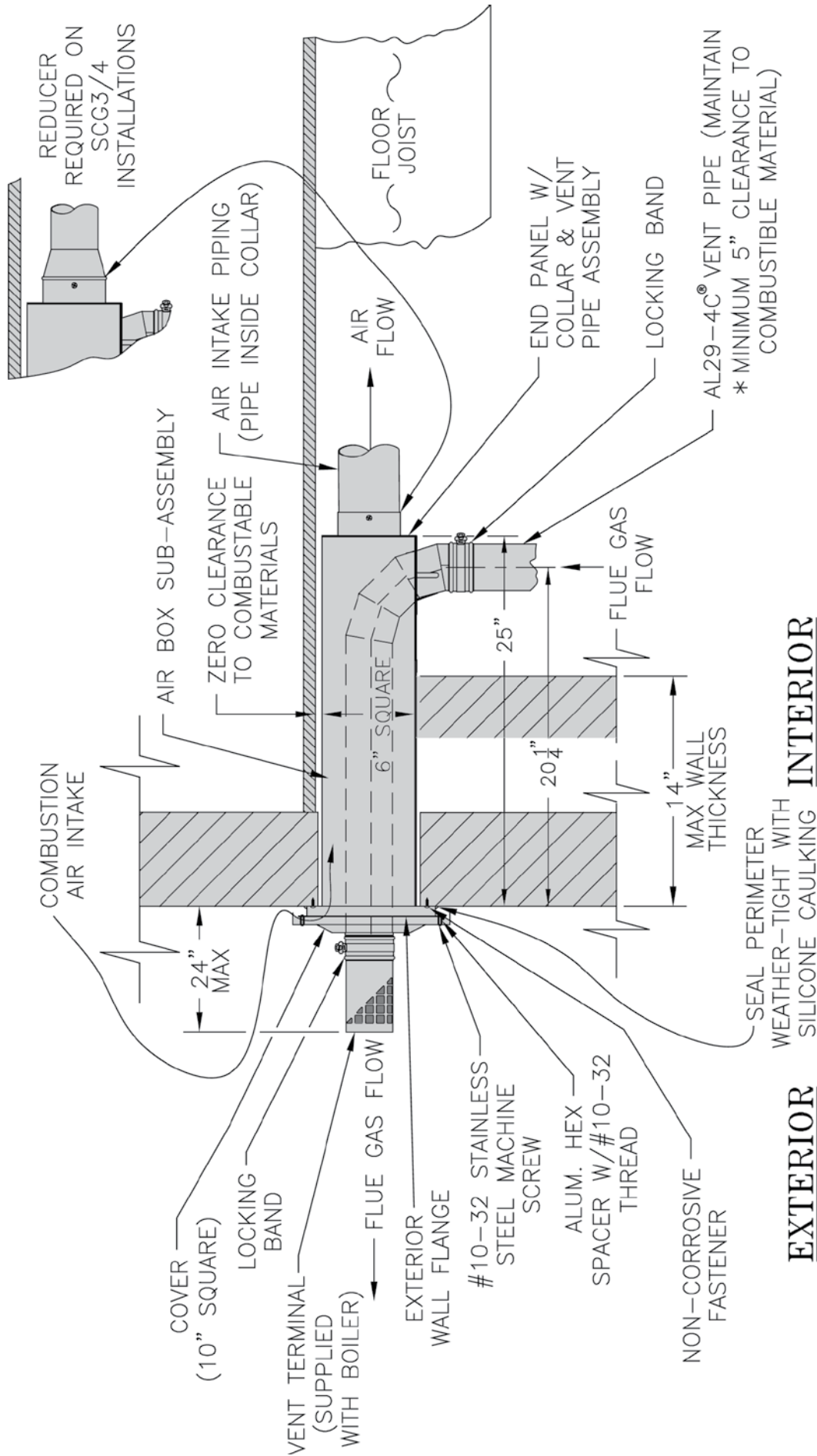

EXTERIOR **INTERIOR**

* VENT PIPE MINIMUM CLEARANCE TO COMBUSTIBLE MATERIAL IS FOUR (4) INCHES WHEN VENT IS INSTALLED IN A FULLY ENCLOSED (CHASE) APPLICATION OR THREE (3) INCHES WHEN VENT IS INSTALLED WITH AT LEAST ONE SIDE OPEN SIMILAR TO A JOIST BAY APPLICATION

Figure 11: Combination Horizontal – Vent/Air Terminal Installation (SCG-3 thru 6)

G. Combination Vertical Venting System – SCG-3 Through SCG-6 ONLY – See Figures 12, 13 and 14.

NOTICE

This vent system requires components not supplied with the boiler.

Description	Part Number	
	SCG-3 & SCG-4	SCG-5 & SCG-6
Vent Carton Part Number	100222-01	100223-01
Air Intake Tee	100224-01	100225-01
Termination Adapter	100226-01	
Saf-T / U.S. Boiler Vent Adapters	102386-01	

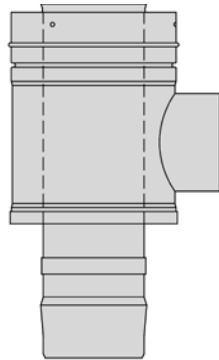

AIR INTAKE TEE

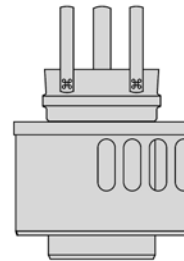

VERTICAL TERMINATION ADAPTER

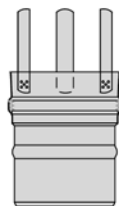

U.S. BOILER VENT TO SAF-T ADAPTER



SAF-T TO U.S. BOILER VENT ADAPTER

COMBINATION VERTICAL VENT SYSTEM COMPONENTS

1. Saf-T Vent SC is an advanced concentric vent system designed for zero clearance installation in residential applications. The inner wall is constructed from superferritic AL29-4C® stainless steel. The outer wall is also constructed from stainless steel, providing durability and a lasting finish.
2. **As a Special Gas Vent system:** Saf-T Vent is approved for use on ANSI Category I, II, III, and IV Gas-Burning Appliances and certain Direct Vent Appliances. Saf-T Vent SC is appropriate for use on appliances that specify an AL29-4C venting system.
3. **As a Sealed Combustion system:** The unique concentric design of Saf-T Vent SC also allows it to function as a pipe-in-a-pipe vent. Products of combustion are exhausted out through the inner wall while combustion air is drawn in through the outer wall. An appliance can be direct-vented with only a single penetration through the building structure. **This application must be approved by the Appliance Manufacturer.**

Note: Saf-T Vent SC includes an integral seal and does not require RTV sealant. However, sealant may be necessary when connecting Saf-T Vent SC components directly to certain appliance flue collars and to the gasket-less Saf-T Vent GC and Saf-T Vent CI vent systems.

For applications up to 550°F/288°C, approved sealants include GE RTV 106 and Dow Corning 736.

For applications up to 300°F/149°C, approved sealants include GE RTV 106 and Dow Corning 732.

4. **Pre-Installation Considerations:**
 - Proper planning prior to installation is essential as to avoid possible contact with concealed plumbing or electrical wiring inside walls, floors or ceilings as well as maintaining proper clearances. Be sure to plan a sufficient number of supports for the entire system that will maintain the required straight-line pitch and hold

the system in place. A continuous straight-line pitch of at least ¼” (2°) to the foot on horizontal runs must be maintained in order to properly rid the system of the corrosive condensate.

5. General Installation Requirements:

- Saf-T Vent SC vent sections, or other Saf-T Vent products, *must* be used throughout the entire length of the system. Alternatives such as galvanized pipe, PVC, nonmetallic pipe, prefabricated chimney, field-fabricated vents or Type B vent sections must not be used. Do not mix pipes, fittings, or joining methods from different manufacturers.
- More than one appliance may not be interconnected to any part of the venting system.
- Any penetrations of ceilings, floors or walls must be properly fire-stopped.
- Whenever gas-burning equipment is installed in the same space where halogenated substances may exist (refrigerants, solvents, bleaches, salts, etc.), clean outside air must be utilized for combustion.
- The vent system shall not be routed into, through or within any other actively used vent or chimney.
- Seal weather exposed joints of the outer jacket with foil tape or an exterior grade silicone sealant.
- Combustible Material is any material made of or surfaced with wood, compressed paper, plant fibers, or other materials that are capable of being ignited or burned. Such material shall be considered combustible even though it is flame-proofed, fire-retardant, or plastered. (Source: NFPA54/ANSI Z223.1-1999.)
- Non-Combustible Material is any material that is not capable of being ignited and burned, such material consisting entirely of, or a combination of, steel, iron, brick, tile, concrete, slate, asbestos, glass and plaster. (Source: NFPA54/ANSI Z223.1-1999.)

CLEARANCES TO COMBUSTIBLES:

Diameter	Clearance to Combustible Material	Maximum Flue Gas Temp. (°F)	Orientation	Enclosure
3" - 4"	0"	550	Vertical, No Offsets	Fully enclosed by combustible material on all sides
		330	Horizontal, Vertical with Offsets	
	1"	400		
	0"	400		Unenclosed, at least 1 side open, combustible material on a maximum of 3 sides
	1"	550		
	0"	550	Any	Noncombustible material

- For a venting system that extends through any zone above that on which the connected appliance is located (except for one and two family dwellings), the vent system shall be enclosed with an enclosure having a fire resistance rating equal to or greater than that of the floor or roof assemblies through which it passes.
- Design any enclosure to permit inspection of the system.
- Do not place any type of insulation in any required clearance spaces surrounding the vent system.

6. Vertical Installation Requirements:

- Seal weather exposed joints of the outer jacket with foil tape or an exterior grade silicone sealant.**
- The vent system must terminate at least 3 feet above the roof line and at least 2 feet higher than any portion of the building within 10 feet.
- When terminated at a height of more than 6 feet the stack must be supported by a support bracing. The vent should be supported every 10 feet.
- The total continuous distance of the vent system from the appliance flue collar to the termination shall not exceed that specified in the appliance manufacturer's installation instructions.
- In cold climates do not install a condensate drain on the exterior of the building. Doing so may result in dangerous icy conditions on surfaces near the drain and may cause damage to the vent system and/or the building exterior.
- Install supports every 10 feet vertically along the vent pipe route. Vertical supports are required after every transition to vertical and are required after every offset elbow. When the vent is free standing and penetrates a roof/ceiling another means of support must be used at a second location. Refer to the Vertical Supports section in this manual.

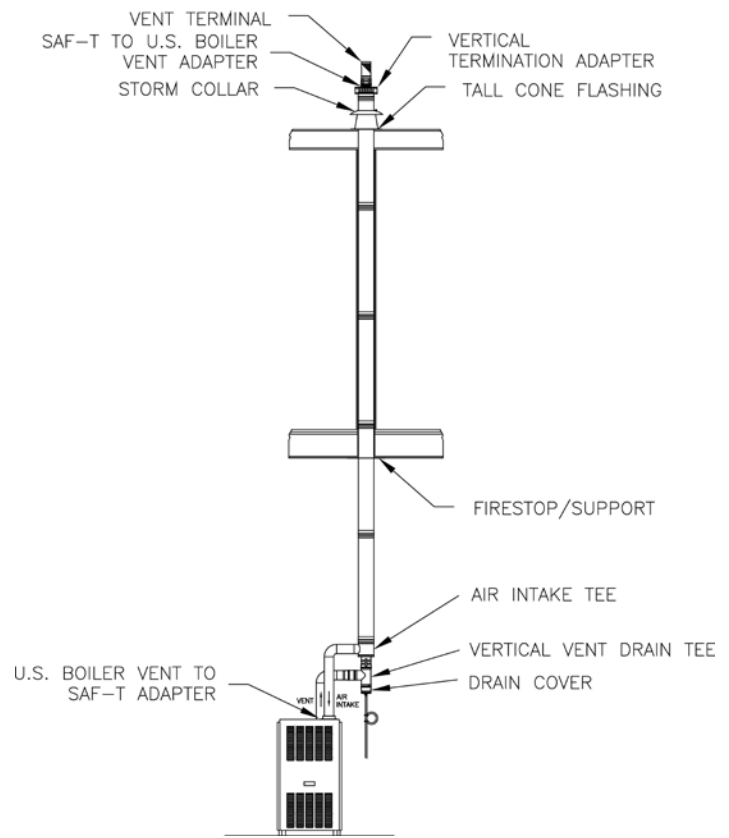
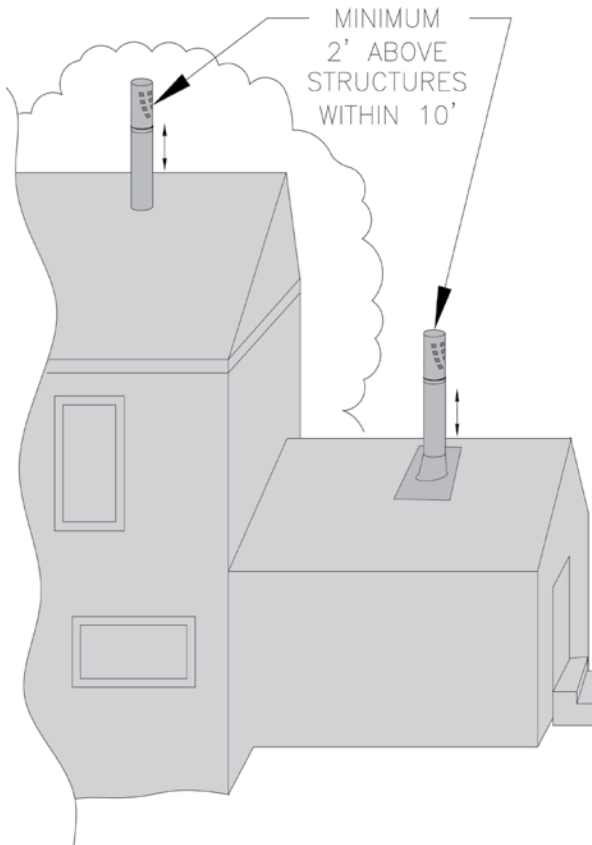

7. Joint Assembly Instructions:

- a. Before joining the sections or fittings together, use an alcohol pad to wipe the joint area of both ends of the inner pipe. This will remove any foreign matter which may affect the integrity of the seal. Install the system with the female ends (ends with the red seal) pointing away from the appliance. (Unless specified differently by the appliance manufacturer.)

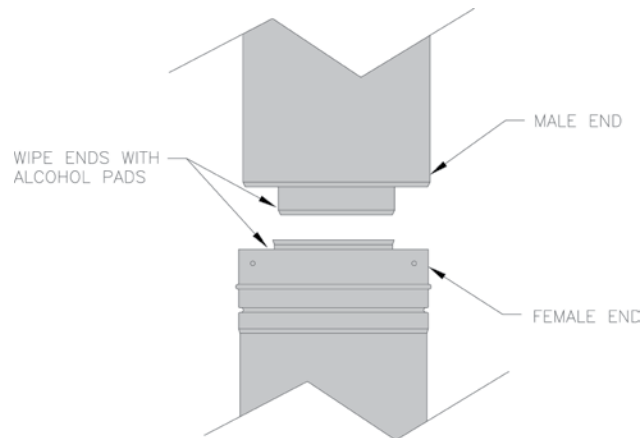

- b. Insert the male end of the inner pipe into the female end of the previous section. In extremely dry conditions it may be helpful to moisten the seal with clean water prior to assembly. Push firmly until the outer jacket has made contact with the snap ring located inside the female end of the previous section. When fully assembled the outer female end will overlap the male end 1".

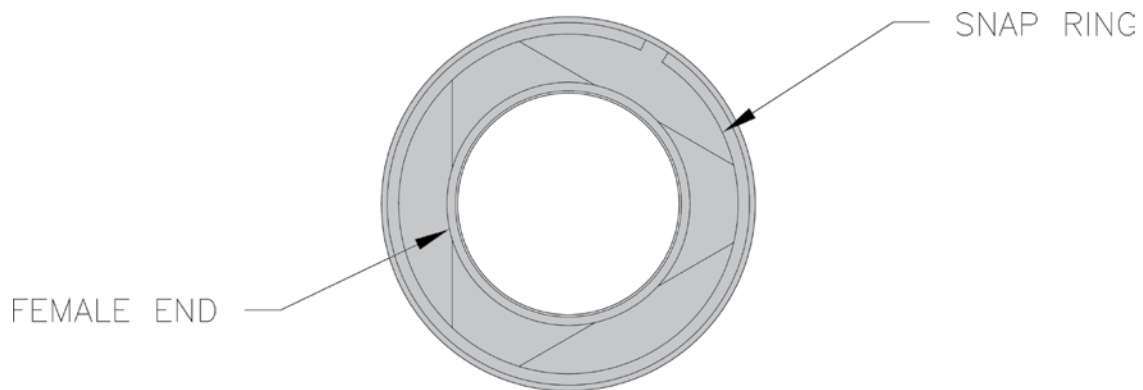

- c. Use the three (3) self-tapping screws provided to connect the outer vents. No pre-drilling is required.

NOTICE

Do not overtighten. If using a variable torque drill, use a low torque setting to install screws, as not to strip out the holes. If a hole becomes stripped due to overtightening, a larger diameter screw (1/2" long max.) or short pot rivet can be used.

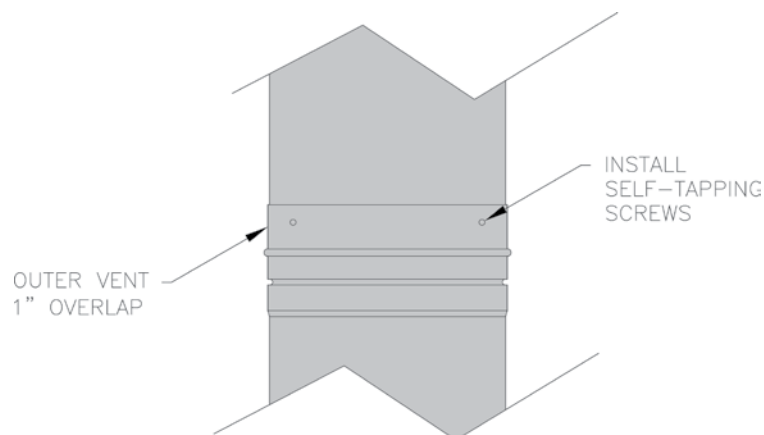

8. Straight Sections Cut To Length:

If a custom length of SC is necessary, a standard vent section can be cut.

- Measure the distance of the length needed, taking the measurement from the end of one of the outer jackets to the beginning of the other outer jacket on the section to connect to, (A to B on diagram).
- Select a section that is longer than the required length.
- It will be necessary to disassemble the vent prior to cutting.
Stand the section on end with the holes up. Find the end of snap ring and pry it out of its groove, being careful not to damage the ends of the vent pipes. Pull up on end of the snap ring and pull it out from the end of the pipe. It may want to spiral out as it is removed. After the snap ring is removed, the inner vent pipe can be separated from the outer jacket.
- Add 2" to the distance measured previously for the cut length of the outer jacket. Mark a cut line on the outer jacket on the male end (the end without holes in it).

An effective way of marking is to run a length of tape around the section, assuring a square cut.

- Add 3" to the distance measured previously for the cut length of the inner vent pipe. Mark a cut line on the inner vent on the male end (the end without the red seal).

The inner pipe is always cut 1" longer than the outer pipe.

- WEAR GLOVES**, as cut ends are very sharp. Cut the pipes with an abrasive cutoff saw, plasma cutter, or compound snips. If using snips, start the cut at the male end and follow a spiral path around the pipe until the cutoff mark is reached. File off any burrs or rough edges that develop in the cutting process and clean off any dust or grit. If the cutting process distorts the roundness of the pipes, carefully use your thumbs to re-round the ends.
- Reassemble the inner vent into the outer jacket and reinstall the snap ring into the groove. Push the inner vent into the outer jacket until the triangle on the inner vent is seated firmly against the bead on outer jacket. Start one end of the snap ring into the groove of the outer pipe. Slowly turn and feed the snap ring into the groove in a spiral motion, and continue around the pipe until the snap ring is fully inserted. Ensure that the triangle on the inner vent is all the way down against the bead of the outer jacket by pushing in firmly. Also ensure that the snap ring is completely in the groove all the way around outer jacket.

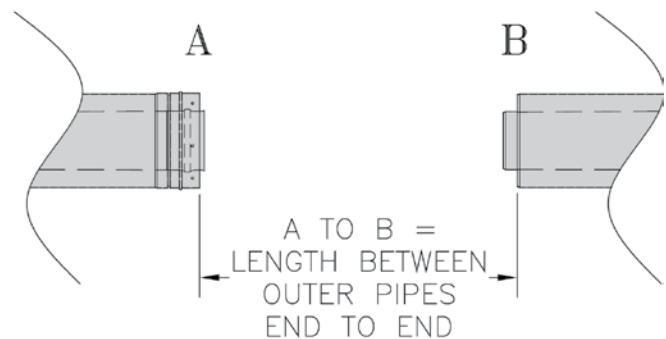
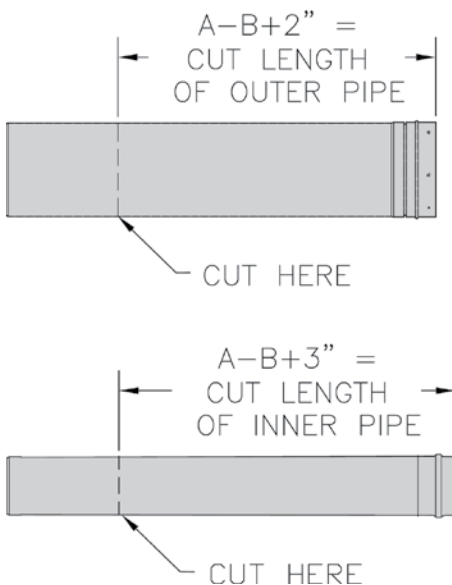

9. Air Intake Connections for Direct Vent and Sealed Combustion Appliances*:

The Air Intake Tee may be used on approved direct vent and sealed combustion appliances that have separate (non-concentric) air intake and flue exhaust collars. The male end of the tee connects to EZ Seal appliance adapters and the tee takeoff/snout connects to the appliance air intake.

- Insert the male end of the Air Intake Tee into the female end of the EZ Seal vent section or appliance adapter and complete the ring and tab connection.
- Insert the male end of the next SC section into the female end of the Air Intake Tee and secure as described elsewhere in this manual.
- Connect the tee takeoff to the appliance combustion air inlet using appropriate hose or pipe.

* Direct Vent Appliances are constructed and installed so that all air for combustion is supplied directly from the outside atmosphere. The passage for the combustion air is allowed a small amount of leakage in the building environment. No special installation considerations are required to use Saf-T Vent SC on Direct Vent appliances unless specified by the appliance manufacturer. Sealed Combustion appliances are similar to Direct Vent except the combustion air passage must be sealed to prevent leakage within the building envelope. When Saf-T Vent SC is used on approved Sealed Combustion appliances the joints of the outer jacket must be sealed with a foil tape (example: 3M 425), or approved silicone sealant (example: Dow Corning 732).

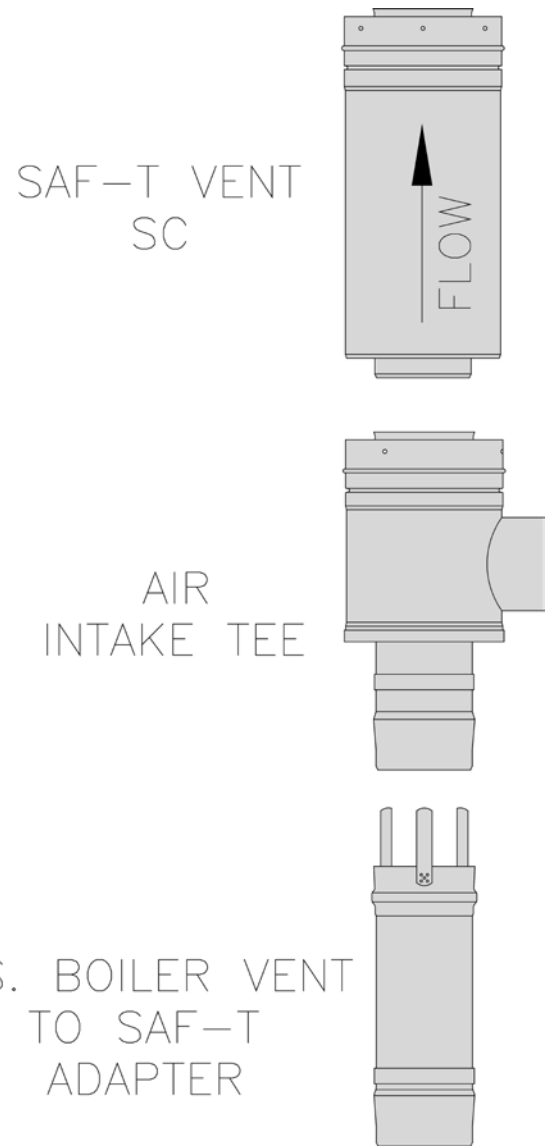

10. Condensate Drains:

When An Internal Condensate Drain is NOT Part of the Appliance:

- A Saf-T Vent SC In-Line Drain Section is strongly recommended. Install this drain fitting as close to the appliance flue collar as possible.
- A condensate drain is required for every 30 feet of horizontal vent and at/near the bottom of a vertical stack.
- Use the In-Line Drain Section for a straight horizontal or vertical run. When used horizontally, rotate the fitting so that the drain tube is as vertical as possible.
- A Condensate Drain Tube Kit is available to direct the condensate to an appropriate location, i.e. floor drain or vented sanitary sewer connection. A trap loop must be formed into the drain hose and must be a diameter that is at least four (4) times the appliance's rated stack pressure in inches of water column or 3 inches, whichever is greater. Secure the loop with a cable tie. Prior to final assembly the trap loop must be 'primed' by pouring a small quantity of water into the drain hose. Inspect at least annually to verify the trap is 'primed'.
- Follow all local and national codes and regulations for the draining of acidic condensate.
- In cold climates do not install a condensate drain on the exterior of the building. Doing so may result in dangerous icy conditions on surfaces near the drain and may cause damage to the vent system and/or the building exterior.

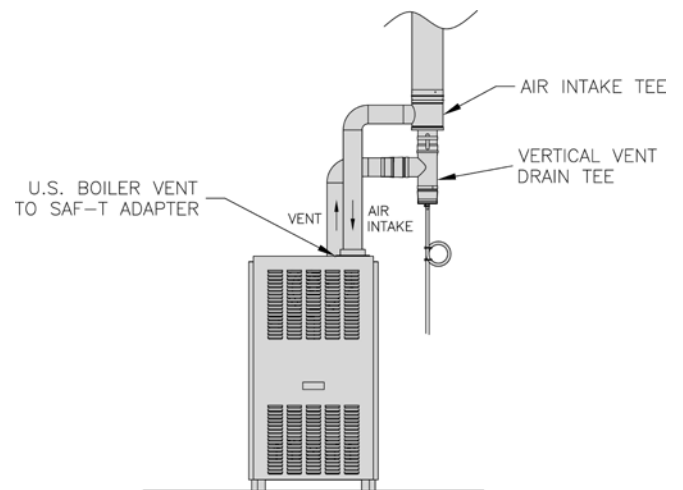

11. Horizontal Supports:

Saf-T Vent SC must have supports for every six (6) feet of horizontal run and after every transition from vertical to horizontal. Support hangers by themselves do not maintain the necessary clearances to combustible materials; be sure to consider clearances when planning the system.

The supports must be secured to solid material using at least #10 fasteners. Do not fasten supports to drywall sheathing without using hollow wall anchors. The conduit supports must maintain the 1/4" per foot pitch to avoid collection of condensate in the vent. Position the vent so that the welded seam is on the top.

0" Clearance Support Clamp, (SC__SUP): Attach the bracket to the structure but do not tighten in place. Open the hose clamp and slip it under the support bracket. Position the clamp between the mounting screws and rotate the clamp so that the screw housing will be accessible after the vent is installed. Restart the threads on the hose clamp and securely tighten the mounting screws to the structure. This can also be installed vertically.

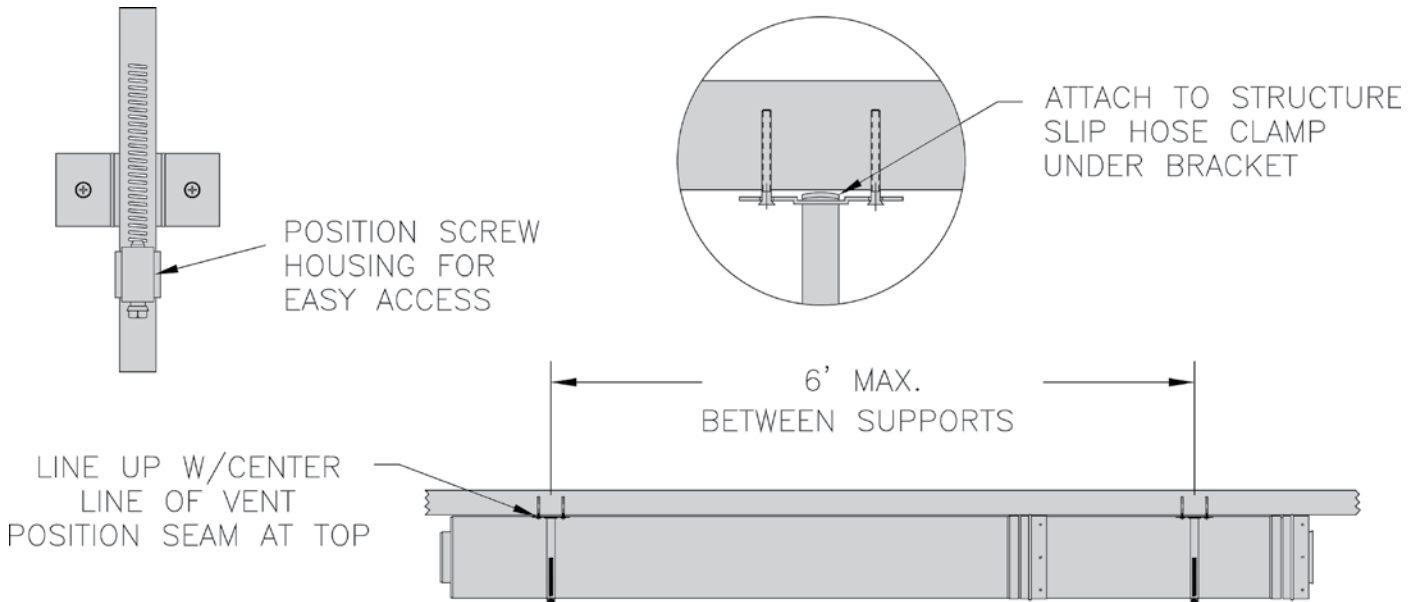

1" Clearance Support Clamp, (SC__SUP1): Supports the vent at 1" clearance to the structure. Line up the support mounting brackets so that the mounting screws will follow the center line of the vent section. This can also be installed vertically.

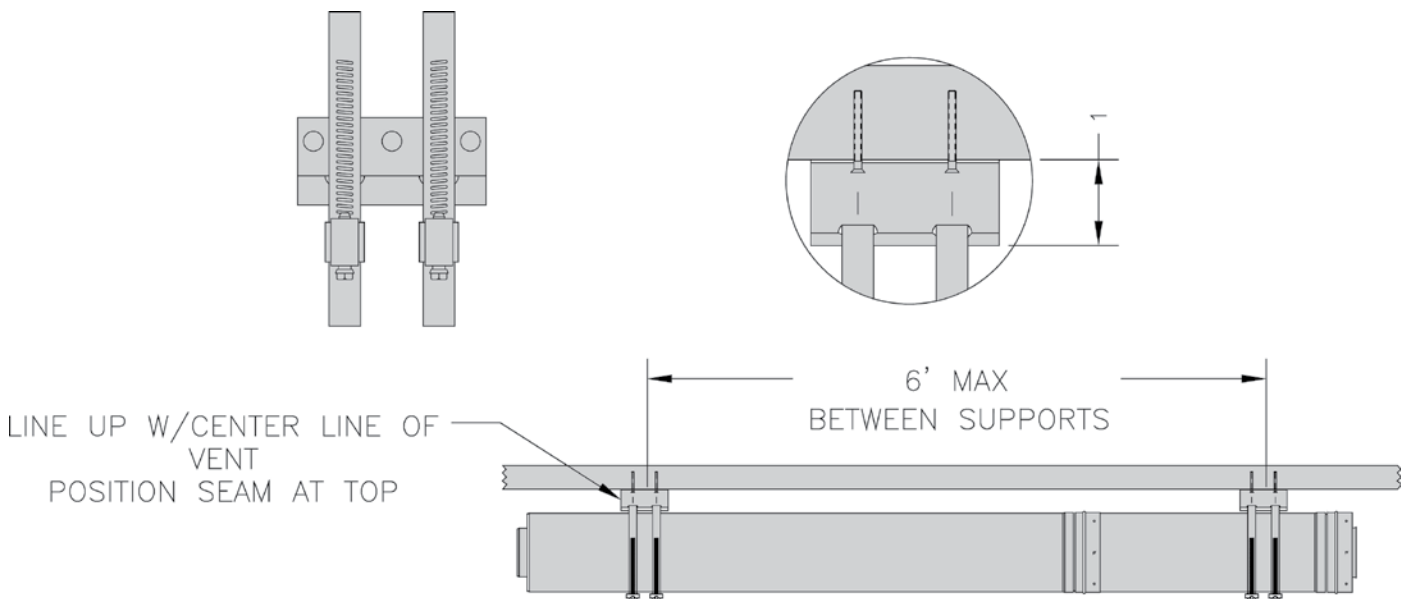

Support Clamp, (4__27SS): Support clamps are sold in pairs and can be clamped around the vent and suspended from a rod or cable. They can be used singularly as a saddle clamp to rest the vent in and suspended from two (2) rods or cables.

Support Legs Rotated Horizontally: Support legs can be used on horizontal runs by rotating the clamp at the rivet connection. The legs can be cut to shorter lengths if necessary.

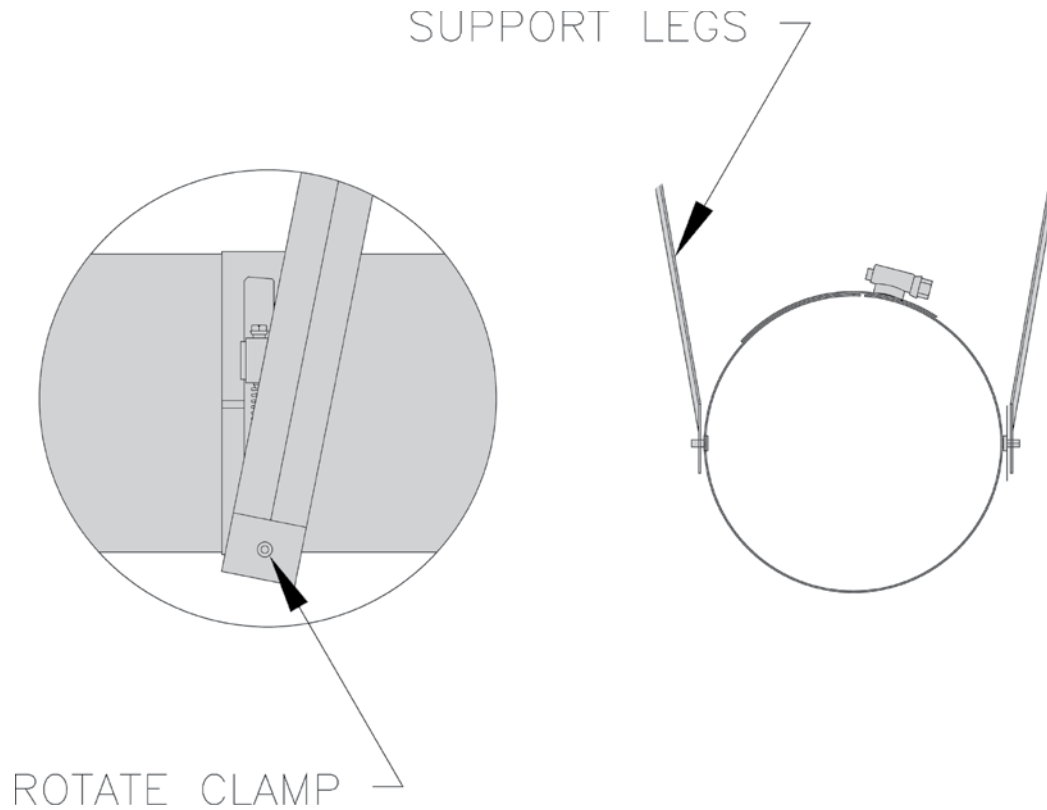

Vertical Supports, (SC__VSL): Vertical support legs can be used above or below a structure for support. To install, slide the support clamp over the end of the vent section, leaving the clamp loose. Position the support legs and install two (2) screws through each leg into the structure. Tighten the clamp around vent pipe. The legs can be cut to shorter lengths if necessary and can rotate around the support clamp at the rivet connection. By rotating the clamp to a horizontal position the support legs can be used on horizontal runs.

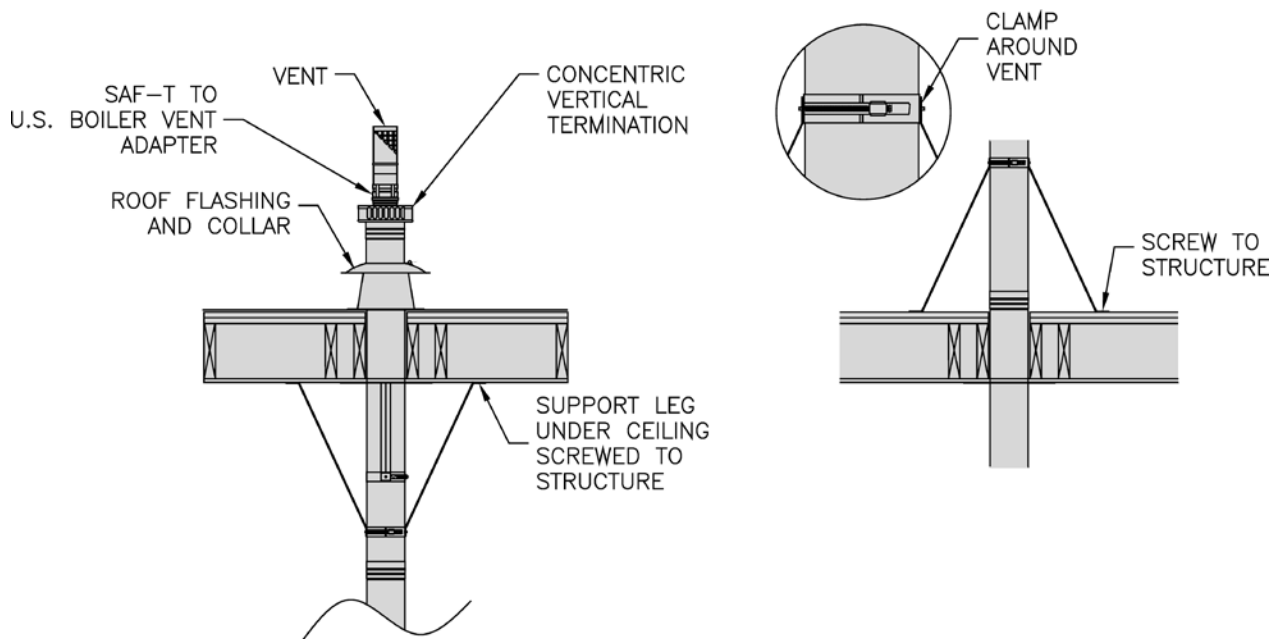

Fire Stop/Wall Thimble/Support, (SC__FS):

- The Saf-T Vent SC Fire Stop can be used as a firestop, a wall thimble, or as a support plate.
- To use as a Wall Thimble prepare an opening according to the chart below. Remove any insulation from the opening, using additional framing if necessary. Attach the plate over the center of the opening using appropriate fasteners.

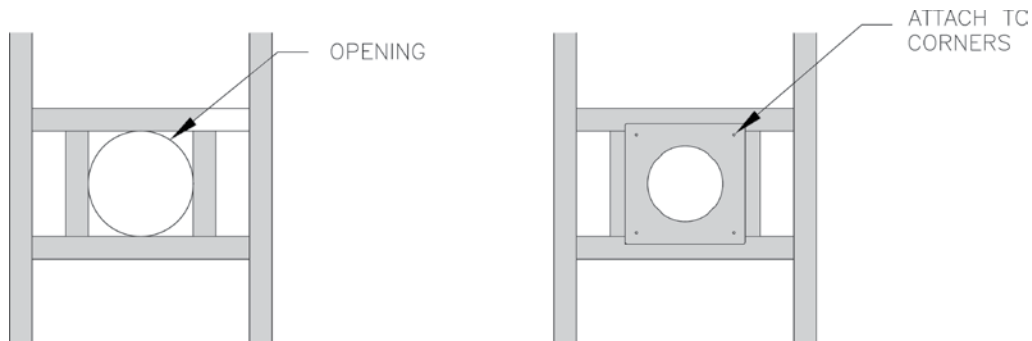

- Install the vent section through the thimble plate and secure the section to the thimble by screwing the self-tapping screws through the holes in the tabs on the plate and into the outer wall of the vent. Apply silicone sealant around the vent section where it passes through the plate and around the plate where it is attached to the structure.
- To use as a Firestop before passing through ceilings or enclosed chases, prepare a round or square opening $\frac{1}{4}$ " larger than the outer jacket ($5\frac{1}{4}$ " for 3" vent or $7\frac{1}{4}$ " for 4" vent). Remove any insulation from the opening. Secure the firestop to the structure at the four (4) corners. Install the vent section through the firestop and secure to the thimble by screwing the self-tapping screws through the holes in the tabs on plate and into outer wall of the vent. This method can also be used to support the vent section either vertically or horizontally.

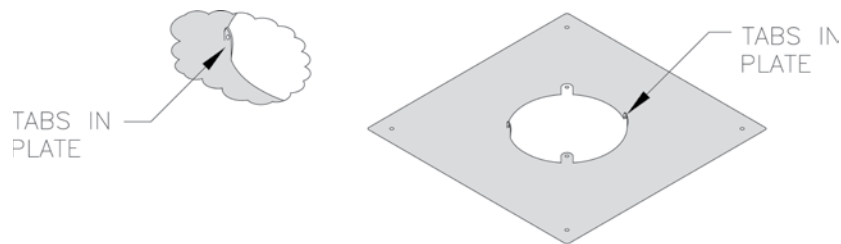

FIRE STOP/WALL THIMBLE/SUPPORT

Tall Cone Flashing:

Directly On Roof or Curb:

Tall Cones are available for flat (SC__TCF), 2/12 pitch (SC__TCFA), and 6/12 - 12/12 pitch roofs (SC__TCFB). Prepare a square or round opening at least $\frac{1}{4}$ " larger than the outer jacket ($5\frac{1}{4}$ " for 3" vent or $7\frac{1}{4}$ " for 4" vent). Remove any insulation from the opening. Apply weather-stripping or outdoor caulk to the bottom of the cone plate and attach the plate to the roof using common construction methods. Flash over the cone plate and seal the fastener heads using normal roofing requirements. When the vent pipe is in place through the Tall Cone, attach a storm collar (sold separately) around the pipe. Apply high temperature silicone sealant around the pipe where it passes through the top of the storm collar. Continue to install vent sections as needed to meet the height requirements by code. **Seal weather exposed joints of the outer jacket with foil tape or an exterior grade silicone sealant.**

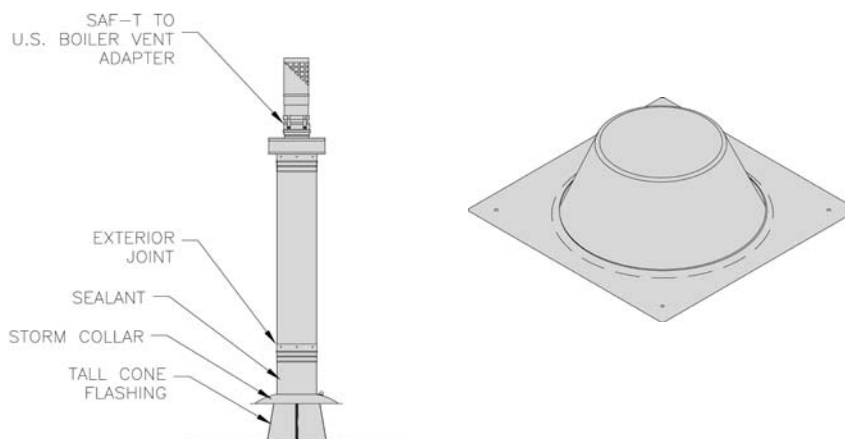

Vertical Terminations, (SC_VT): Install the vertical termination adapter into the last vent section and secure with the three (3) self-tapping screws provided. Attach the “Saf-T to U.S. boiler Vent Adapter”, then attach the vent terminal. If the exhaust termination needs to be extended, a section of EZ Seal vent can be connected directly to the vertical termination adapter. **Seal weather exposed joints of the outer jacket with foil tape or an exterior grade silicone sealant.** To allow for inspection of the system, do not seal the exhaust termination.

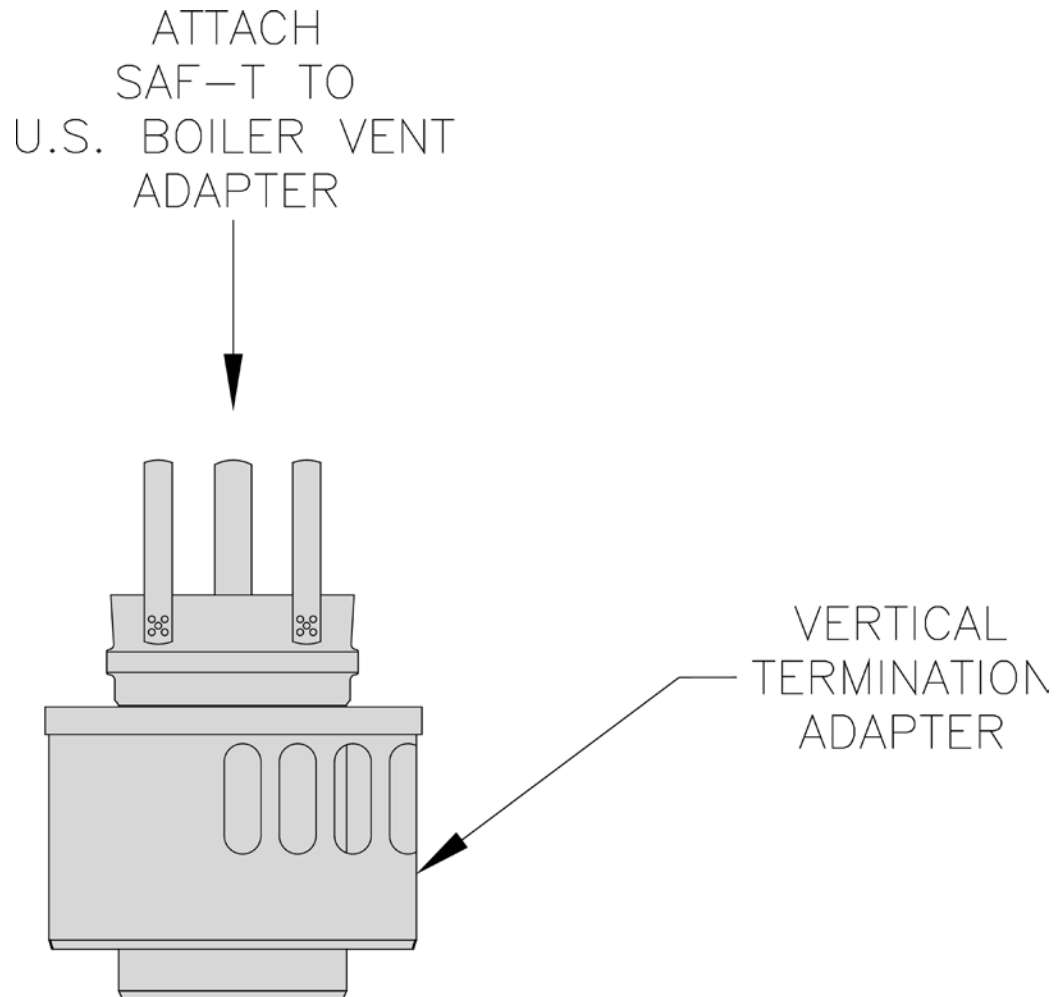

H. Indoor Air Installation – See Figures 12, 13, 14, 15 and 16.

1. Do not exceed maximum vent length. Refer to Table 4.

Horizontal –

2. Maintain minimum $\frac{1}{4}$ inch per foot slope in horizontal runs. Position weld seams in vent pipes, in all horizontal runs, at the top to avoid condensate from lying on the seams.
3. Recommended horizontal installation consists of vent being sloped down away from boiler. See Figure 12.
4. Alternate horizontal installation consists of vent being sloped down toward the boiler. A horizontal vent tee is required. See Figure 13.
5. Use appropriately designed thimbles when passing through combustible walls (thimble use optional for noncombustible walls). Insert thimble through wall from outside. Secure outside flange to wall with nails or screws, and seal with sealant material. Install inside flange to inside wall, secure with nails or screws, and seal with sealant material.
6. For noncombustible wall application when thimble is not used, size opening such that female (bell) end with locking band attached cannot pass through.
7. Join vent terminal to vent pipe. Locate vent terminal between seventeen (17) inches and twenty-nine (29) inches from wall when joined to inside vent piping. See Figure 14.
8. Insert vent pipe through thimble/opening from outside and join to vent system. Apply sealant between vent pipe and opening/thimble to provide weathertight seal.

Vertical –

10. Installation of a vertical vent drain tee is required on all vertical vent applications. See Figure 6. Attach vertical vent drain tee directly to elbow or horizontal pipe from an elbow immediately after vent connector.

11. Install fire stops where vent passes through floors, ceilings or framed walls. The fire stop must close the opening between the vent pipe and the structure. Fire stop manufacturers are Air-Jet, American Metal Products, Metal-Fab, and Simpson Dura-Vent.
12. Whenever possible install vent straight through roof. Refer to Figure 6. Maintain minimum clearance to combustible materials. For attic offset see Figure 7.
13. Install Vent Terminal.
 - a. Size roof opening to maintain minimum clearance from combustible materials.
 - b. Use appropriately designed vent flashing when passing through roofs. Follow flashing manufacturers' instructions for installation procedures. Flashing manufacturers are Air-Jet, American Metal Products, Metal Fab, and Simpson Dura-Vent.
 - c. Extend vent pipe to maintain minimum vertical and horizontal distance of twelve (12) inches from roof surface. Allow additional vertical distance for expected snow accumulation. Provide brace as required. Refer to Figure 15.
 - d. Vertical venting requires flashing and a storm collar to prevent moisture from entering the structure.
 - e. Install storm collar on vent pipe immediately above flashing. Apply Dow Corning Silastic 732 RTV Sealant between vent pipe and storm collar to provide weathertight seal.
 - f. Attach vent terminal.

Vent Terminal and Air Intake Terminal –

14. Join vent terminal to 45° elbow (supplied by installer). Join 45° elbow/terminal assembly to vent pipe. Refer to Section C for proper procedures for joining vent pipe and fittings. See Figure 3.
15. Install supplied air intake terminal. See Figure 16.

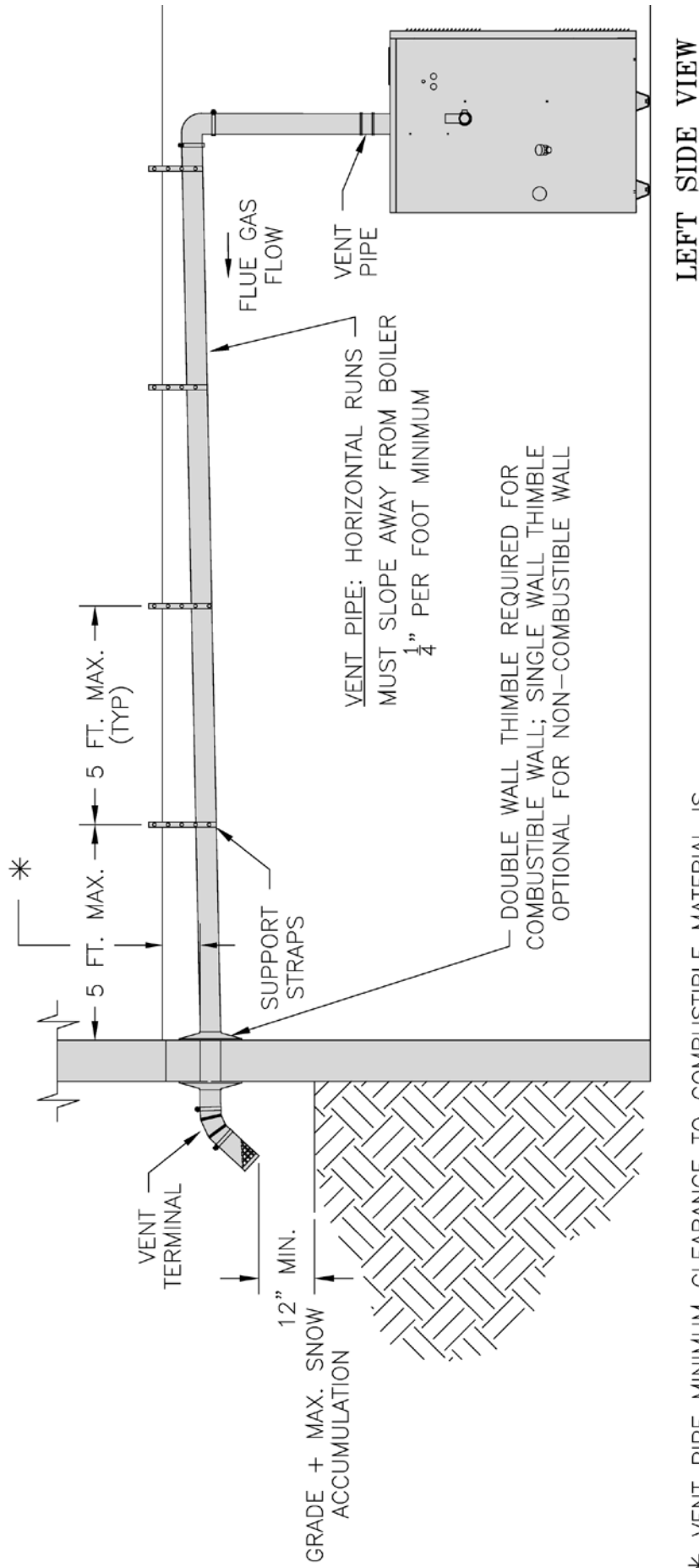

LEFT SIDE VIEW

* VENT PIPE MINIMUM CLEARANCE TO COMBUSTIBLE MATERIAL IS FOUR (4) INCHES WHEN VENT IS INSTALLED IN A FULLY ENCLOSED (CHASE) APPLICATION OR THREE (3) INCHES WHEN VENT IS INSTALLED WITH AT LEAST ONE SIDE OPEN, SIMILAR TO A JOIST BAY APPLICATION.

Figure 12: Recommended Separate Horizontal - Vent Installation

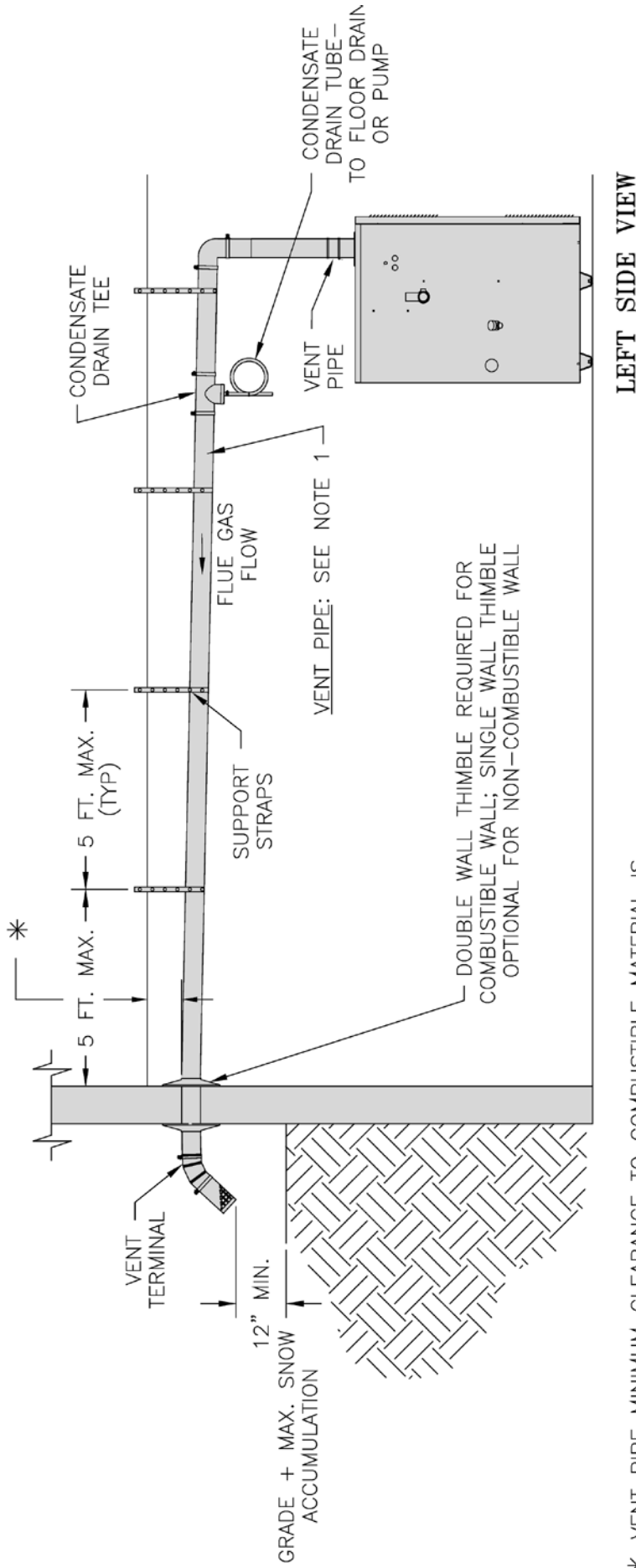

* VENT PIPE MINIMUM CLEARANCE TO COMBUSTIBLE MATERIAL IS FOUR (4) INCHES WHEN VENT IS INSTALLED IN A FULLY ENCLOSED (CHASE) APPLICATION OR THREE (3) INCHES WHEN VENT IS INSTALLED WITH AT LEAST ONE SIDE OPEN, SIMILAR TO A JOIST BAY APPLICATION.

NOTE 1:
 HORIZONTAL RUNS MUST SLOPE TOWARD THE BOILER 1/4" PER FOOT MIN. WHEN USING A CONDENSATE TEE.

Figure 13: Alternate Separate Horizontal - Vent Installation

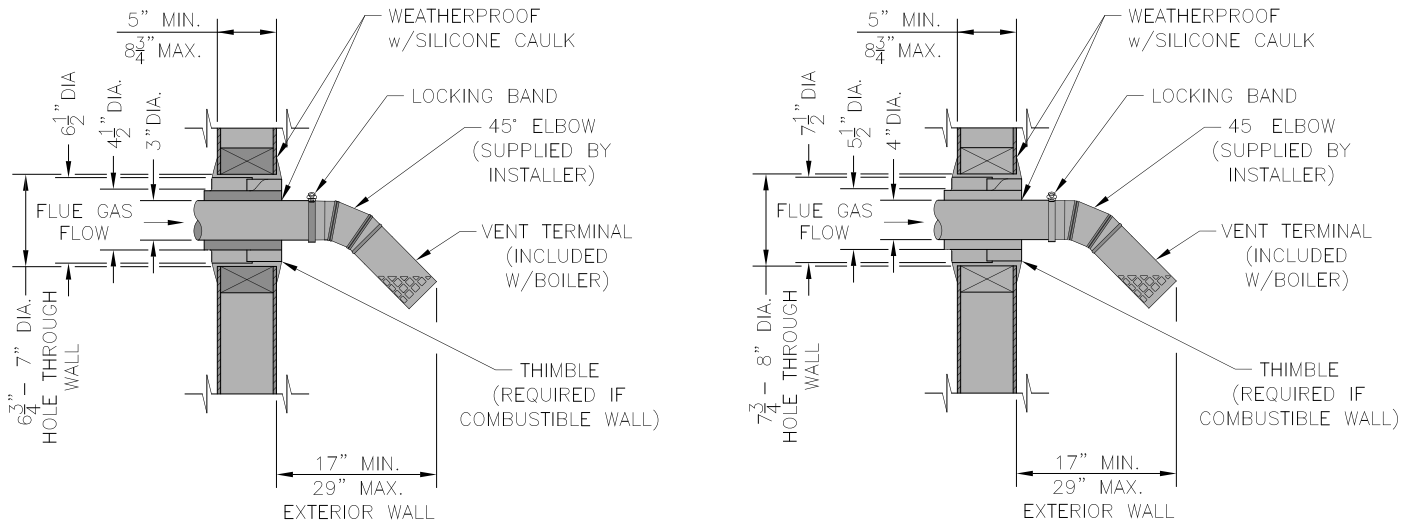

3" HORIZONTAL VENT TERMINAL

4" HORIZONTAL VENT TERMINAL

Figure 14: Optional Indoor Air - Vent Terminal Installation

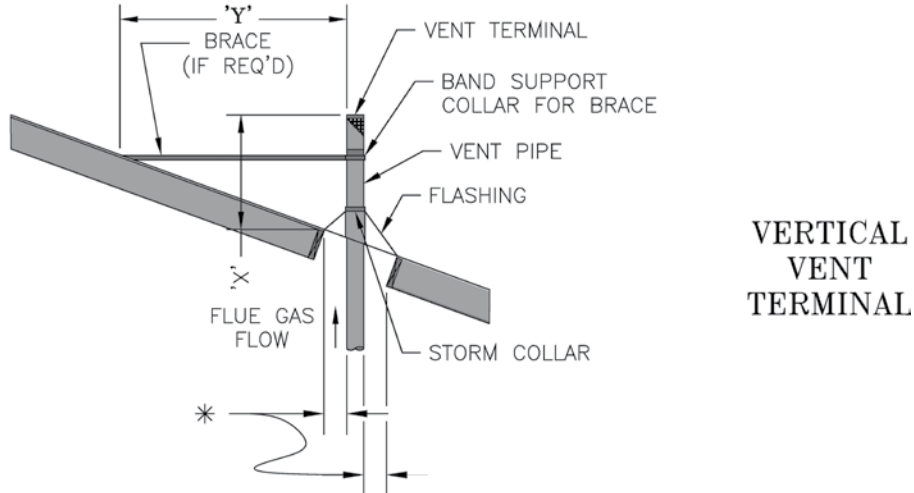

Figure 15: Indoor Air - Vertical Vent Terminal Installation

Extend Vent/Air Intake Piping to maintain minimum vertical ("X") and minimum horizontal ("Y") distance of twelve (12) inches from roof surface. Allow additional vertical ("X") distance for expected snow accumulation.

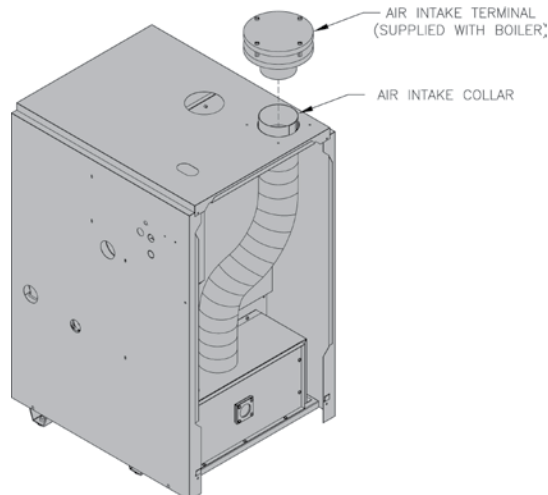

Figure 16: Indoor Air - Air Intake Terminal Installation

I. Optional Exterior Separate Horizontal Vent/Air Intake Terminal Mounting – See Figures 17, 18, 19, 20, 21 and 22.

1. Do not exceed maximum vent/air intake lengths. Refer to Table 4.
2. This installation will allow a maximum of seven (7) feet vertical exterior run of the vent/air intake piping to be installed on separate horizontal venting and indoor air horizontal venting.

NOTICE

Exterior run to be included in equivalent vent/air intake lengths.

3. Install vent piping.
 - a. Install vent piping for desired venting system. Refer to specific section for details for vent pipe installation.
 - b. After penetrating wall/thimble, install an AL 29-4C® 90° elbow so that elbow leg is in the up direction.
 - c. Install maximum of seven (7) feet of AL 29-4C® vent pipe. Refer to Sections C through E for proper procedures for joining vent pipe and fittings.

- d. At top of vent pipe length install an AL 29-4C® 90° elbow so that elbow leg is opposite the building's exterior surface.
- e. If installation requires indoor air, install AL 29-4C® 45° elbow to upper AL 29-4C® 90° elbow so that leg of 45° is in down direction (see Figure 21 or 22). If not using indoor air, proceed to Step f.
- f. Install horizontal vent terminal (provided with boiler).
- g. Brace piping if required.

4. Air Intake Piping (not required for indoor air).
 - a. Install air intake piping for desired venting system. Refer to specific section for details for air intake installation.
 - b. After penetrating wall, install a corrosion resistant 90° elbow so that elbow leg is in the up direction.
 - c. Install maximum of seven (7) feet of corrosion resistant air intake pipe.
 - d. At top of air intake pipe install air intake terminal (provided with boiler).
 - e. Brace piping if required.

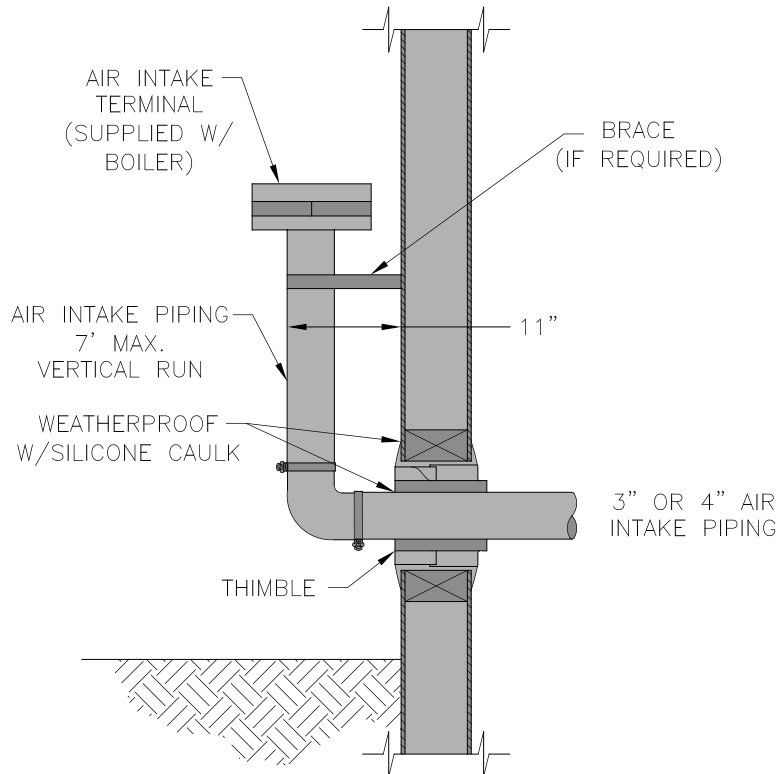

NOTE:
ALL EXPOSED AIR INTAKE PIPING MUST BE CONSTRUCTED OF CORROSION RESISTANT MATERIAL SUCH AS ALUMINUM, STAINLESS STEEL OR PVC.

Figure 17: Optional Separate Horizontal Air 3" or 4" Intake Terminal Installation

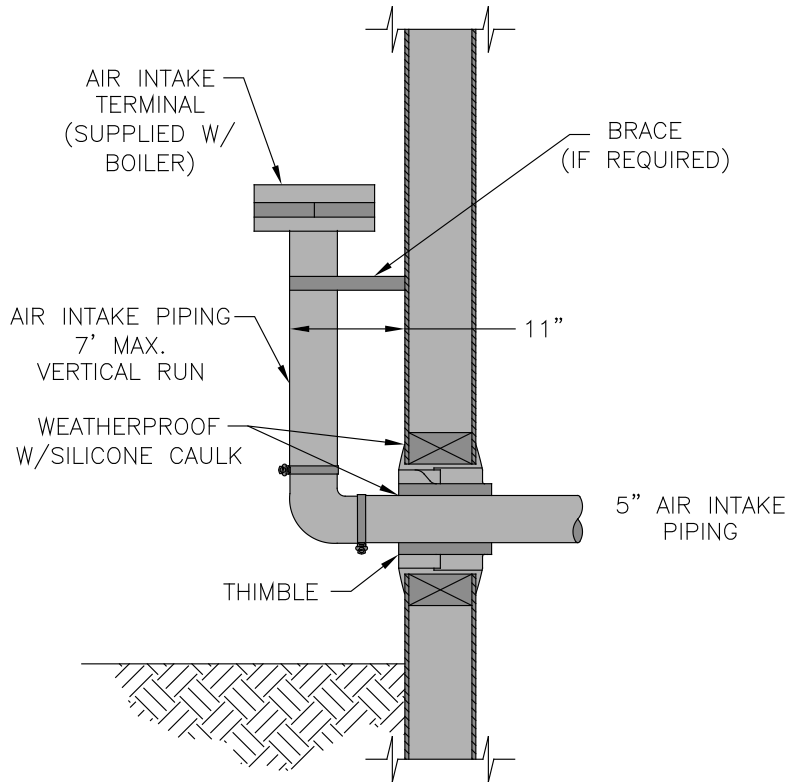

NOTE:
 ALL EXPOSED AIR INTAKE PIPING MUST BE CONSTRUCTED OF CORROSION RESISTANT MATERIAL SUCH AS ALUMINUM, STAINLESS STEEL OR PVC.

Figure 18: Optional Separate Horizontal Air 5" Intake Terminal Installation

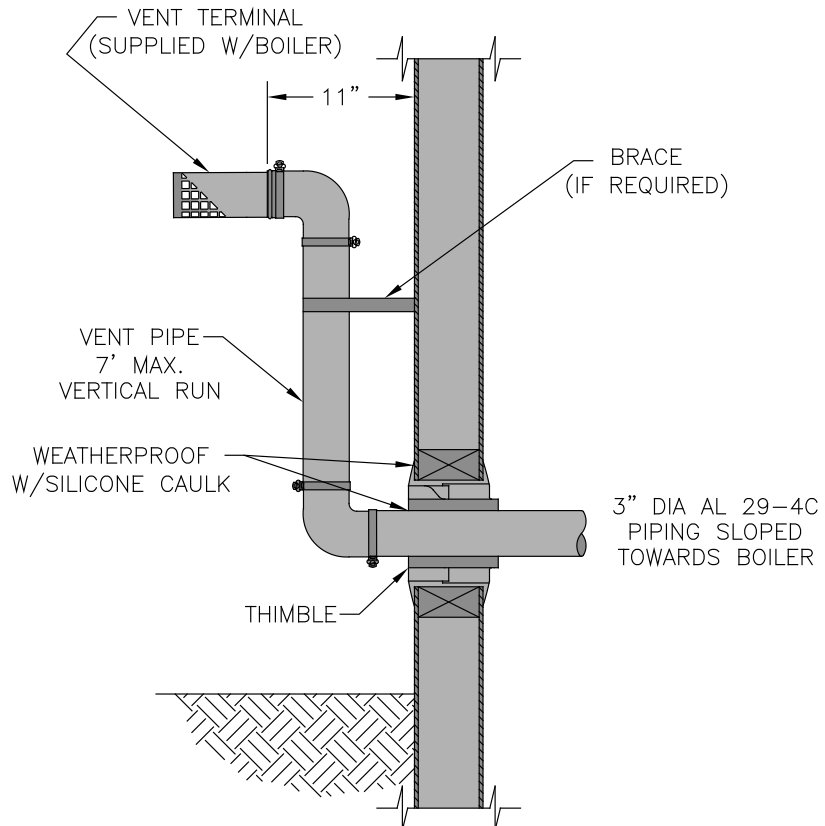

Figure 19: Optional Separate Horizontal 3" Vent Terminal Installation

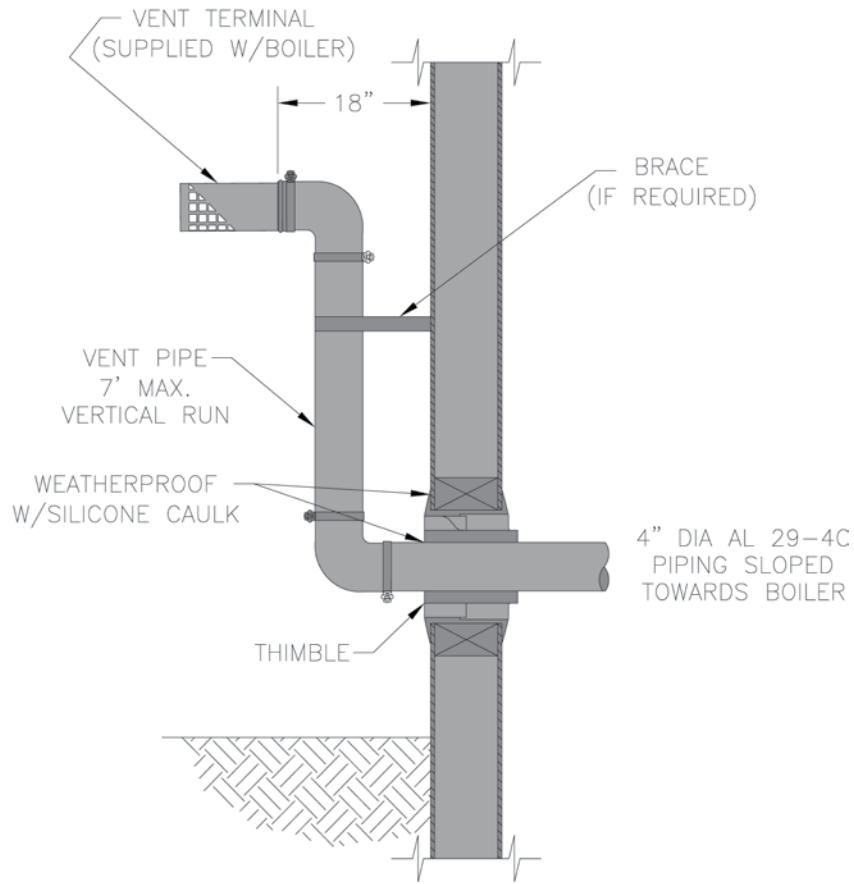

Figure 20: Optional Separate Horizontal 4" Vent Terminal Installation

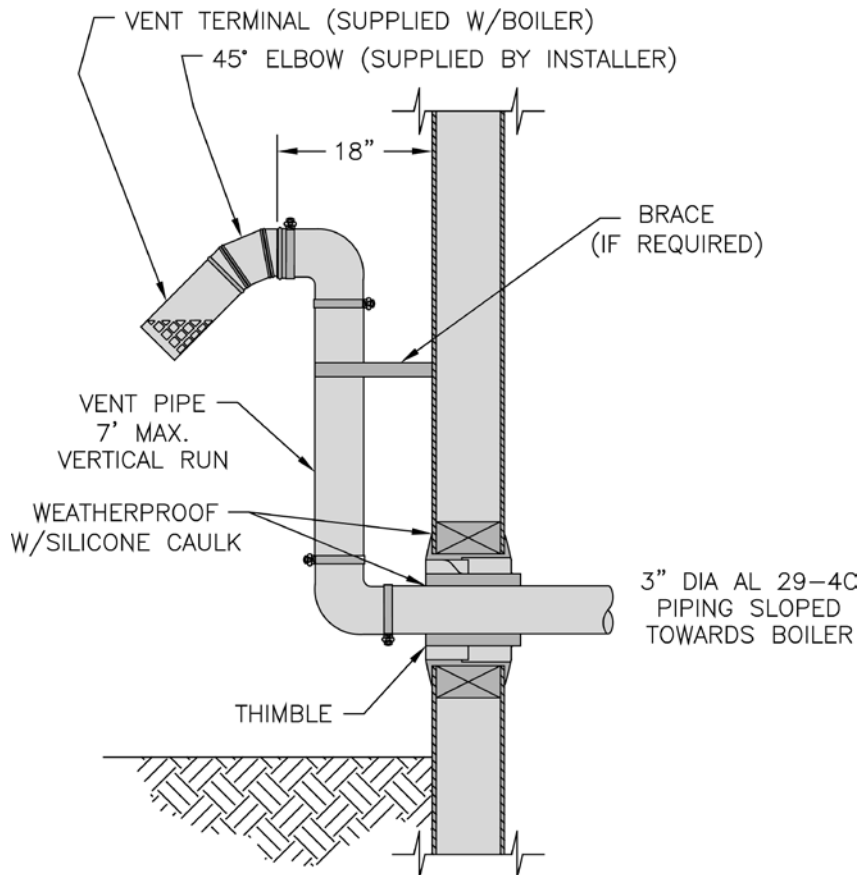

Figure 21: Optional Separate Horizontal 3" Vent Terminal Installation (Indoor Air)

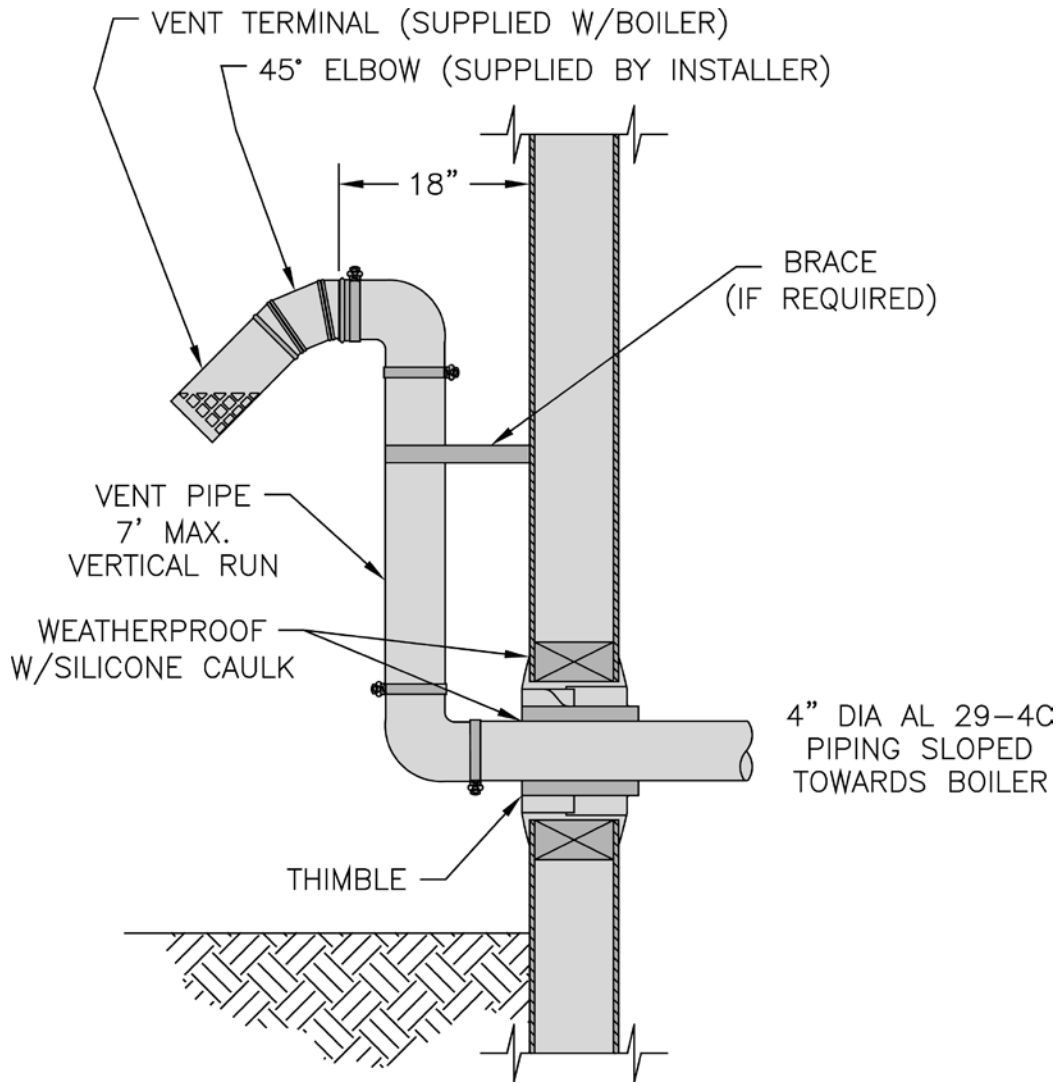

Figure 22: Optional Separate Horizontal 4" Vent Terminal Installation (Indoor Air)

IV. Water Piping and Trim

WARNING

Failure to properly pipe boiler may result in improper operation and damage to boiler or structure.

Oxygen contamination of boiler water will cause corrosion of iron and steel boiler components, and can lead to boiler failure. U.S. Boiler's Standard Warranty does not cover problems caused by oxygen contamination of boiler water or scale (lime) build-up caused by frequent addition of water.

A. Design and install boiler and system piping to prevent oxygen contamination of boiler water and frequent water additions.

1. There are many possible causes of oxygen contamination such as:
 - a. Addition of excessive make-up water as a result of system leaks.
 - b. Absorption through open tanks and fittings.
 - c. Oxygen permeable materials in the distribution system.
2. In order to insure long product life, oxygen sources must be eliminated. This can be accomplished by taking the following measures:
 - a. Repairing system leaks to eliminate the need for addition of make-up water.
 - b. Eliminating open tanks from the system.
 - c. Eliminating and/or repairing fittings which allow oxygen absorption.
 - d. Use of non-permeable materials in the distribution system.
 - e. Isolating the boiler from the system water by installing a heat exchanger.
 - f. Use properly designed and operating air elimination devices in water piping.

B. Low Water Cut Off (LWCO) on Hot Water Boilers (Optional)

WARNING

DO NOT ATTEMPT to cut factory wires to install an aftermarket Low Water Cut Off (LWCO). Only use connections specifically identified for Low Water Cut Off.

In all cases, follow the Low Water Cut Off (LWCO) manufacturer's instructions.

When

A low water cutoff is required to protect a hot water boiler when any connected heat distributor (radiation) is installed below the top of the hot water boiler (i.e. baseboard on the same floor level as the boiler). In addition, some jurisdictions require the use of a LWCO with a hot water boiler.

Where

The universal location for a LWCO on both gas and oil hot water boilers is above the boiler, in either the supply or return piping. The minimum safe water level of a water boiler is at the uppermost top of the boiler; that is, it must be full of water to operate safely.

What Kind

The SCG boiler is designed to accept the wiring of the Safgard Model 1100-H4 (P/N 100592-01) LWCO. This is a probe type LWCO. The factory wiring is designed to allow simple "Plug-in" installation of the wiring.

How to Pipe

A "tee" is commonly used to connect the probe LWCO to the supply or return piping, as shown below.

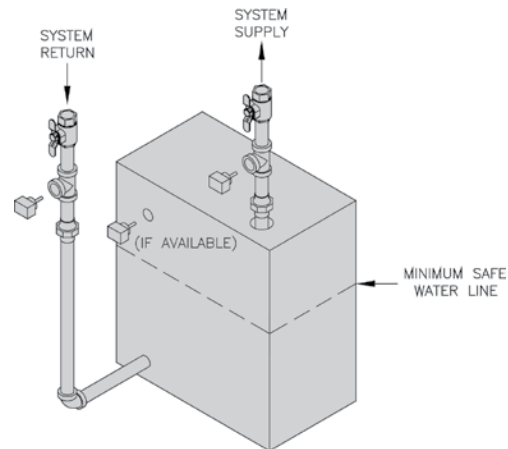

LWCO Location

Select the appropriate size tee using the LWCO manufacturer's instructions. Often, the branch connection must have a minimum diameter to prevent bridging between the probe and the tee. Also, the run of the tee must have a minimum diameter to prevent the end of the probe from touching or being located too close to the inside wall of the run of the tee.

Ideally, manual shutoff valves should be located above the LWCO and the boiler to allow for servicing. This will allow probe removal for inspection without draining the heating system. Many probe LWCO manufacturers recommend an annual inspection of the probe.

How to Wire

Ensure power is turned off to boiler.
Locate the LWCO jumper wire in the factory wiring harness. Remove the jumper wire and install the LWCO wiring from LWCO Model 1100-H4 (P/N 100592-01) into the plug of the SCG factory wiring.

How to Test

Shut off fuel supply. Lower water level until water level is BELOW the LWCO. Generate a boiler demand by turning up thermostat. Boiler should not attempt to operate. Increase the water level by filling the system. The boiler should attempt to operate once the water level is above the LWCO.

NOTICE

Ensure the location of the LWCO in the piping will allow for connection of the LWCO wiring harness to the factory wiring of the SCG.

- C. Connect system supply and return piping to boiler.**
See Figures 25 and 26. Maintain minimum ½ inch clearance from hot water piping to combustible materials.

NOTICE

U.S. Boiler recommends sizing the system circulator to supply sufficient flow (GPM) to allow a 20°F temperature differential in the system. When sizing the system circulator, the pressure drop of all radiators, baseboard and radiant tubing and all connecting piping must be considered.

- D. Install circulator with flanges, gaskets and bolts provided.** Circulator harness allows circulator to be mounted on supply or return. Connect harness to circulator and secure any excess conduit.
- E. Install supply manifold, pressure/temperature gauge and pressure relief valve.**
See Figure 24. Pressure Relief Valve must be installed with spindle in vertical position. Installation of the relief valve must comply with the ASME Boiler and Pressure Vessel Code, Section IV.

WARNING

Pressure relief valve discharge piping must be piped such that the potential of severe burns is eliminated. DO NOT pipe in any area where freezing could occur. DO NOT install any shut-off valves, plugs or caps. Consult Local Codes for proper discharge piping arrangement.

- F. Space heating and domestic water heating with Alliance SL™ water heater.** Install Alliance SL™ water heater as a separate heating zone. Refer to Alliance SL™ Installation, Operating and Service Instructions for additional information.
- G. If boiler is used in connection with refrigeration systems,** boiler must be installed with chilled medium piped in parallel with the heating boiler using appropriate valves to prevent chilled medium from entering boiler, see Figure 23.

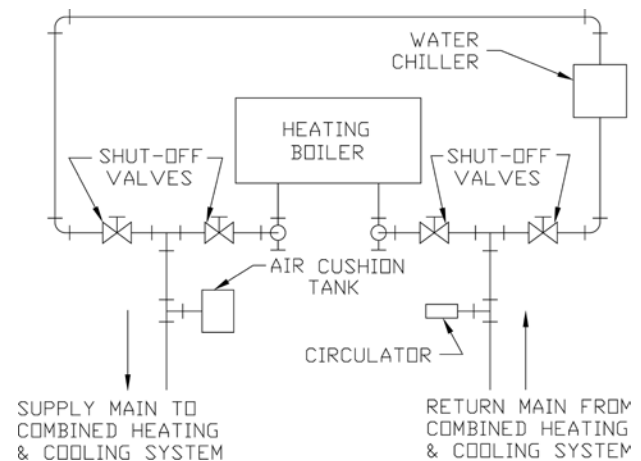

Figure 23: Recommended Piping for Combination Heating & Cooling (Refrigeration) System

- H. If boiler is connected to heating coils located in air handling units where they may be exposed to refrigerated air,** boiler piping must be equipped with flow control valves to prevent gravity circulation of boiler water during operation of cooling system.
- I. Use a boiler bypass** if the boiler is to be operated in a system which has a large volume or excessive radiation where low boiler water temperatures may be encountered (i.e. converted gravity circulation system, etc.).

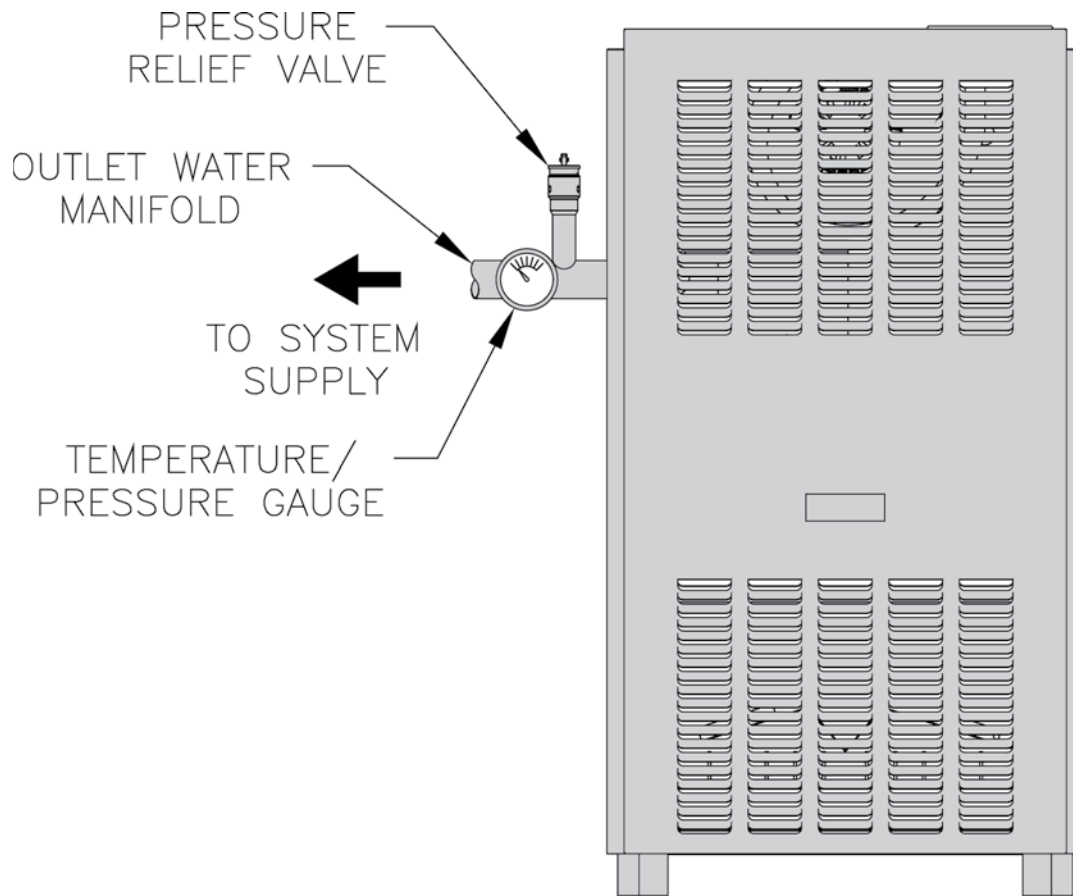

Figure 24: Supply Water Manifold Piping

Install pipe tee between circulator and boiler return along with second tee in supply piping as shown in Figure 25 or 26. Bypass should be same size as the supply and return lines with valves located in bypass and supply outlet as illustrated in Figure 25 or 26 in order to regulate water flow to maintain higher boiler water temperatures.

After the boiler is operational (reference Section VIII. System Start-Up) set by-pass and boiler supply valves to half throttle position to start. Operate boiler until system water temperature reaches normal operating range.

Adjust valves to provide 180° to 200°F supply water temperature. Opening the boiler supply valve will raise system temperature, while opening the by-pass valve will lower system supply temperature.

J. A hot water boiler installed above radiation level must be provided with a low water cutoff device as part of installation.

K. If a low water cutoff is required, it must be mounted in the system piping above the boiler. The minimum safe water level of a hot water boiler is just above the highest water containing cavity of the boiler; that is, a hot water boiler must be full of water to operate safely.

L. Oil, grease, and other foreign materials which accumulate in new hot water boilers and a new or reworked system should be boiled out, and then thoroughly flushed. A local qualified water treatment chemical specialist is a suggested source for recommendations regarding appropriate chemical compounds and concentrations which are compatible with local environmental regulations.

M. After the boiler and system have been cleaned and flushed, and before refilling the entire system add appropriate water treatment chemicals, if necessary, to bring the pH between 7 and 11.

N. If it is required to perform a long term pressure test of the hydronic system, the boiler should first be isolated to avoid a pressure loss due to the escape of air trapped in the boiler.

To perform a long term pressure test including the boiler, ALL trapped air must first be removed from the boiler.

A loss of pressure during such a test, with no visible water leakage, is an indication that the boiler contained trapped air.

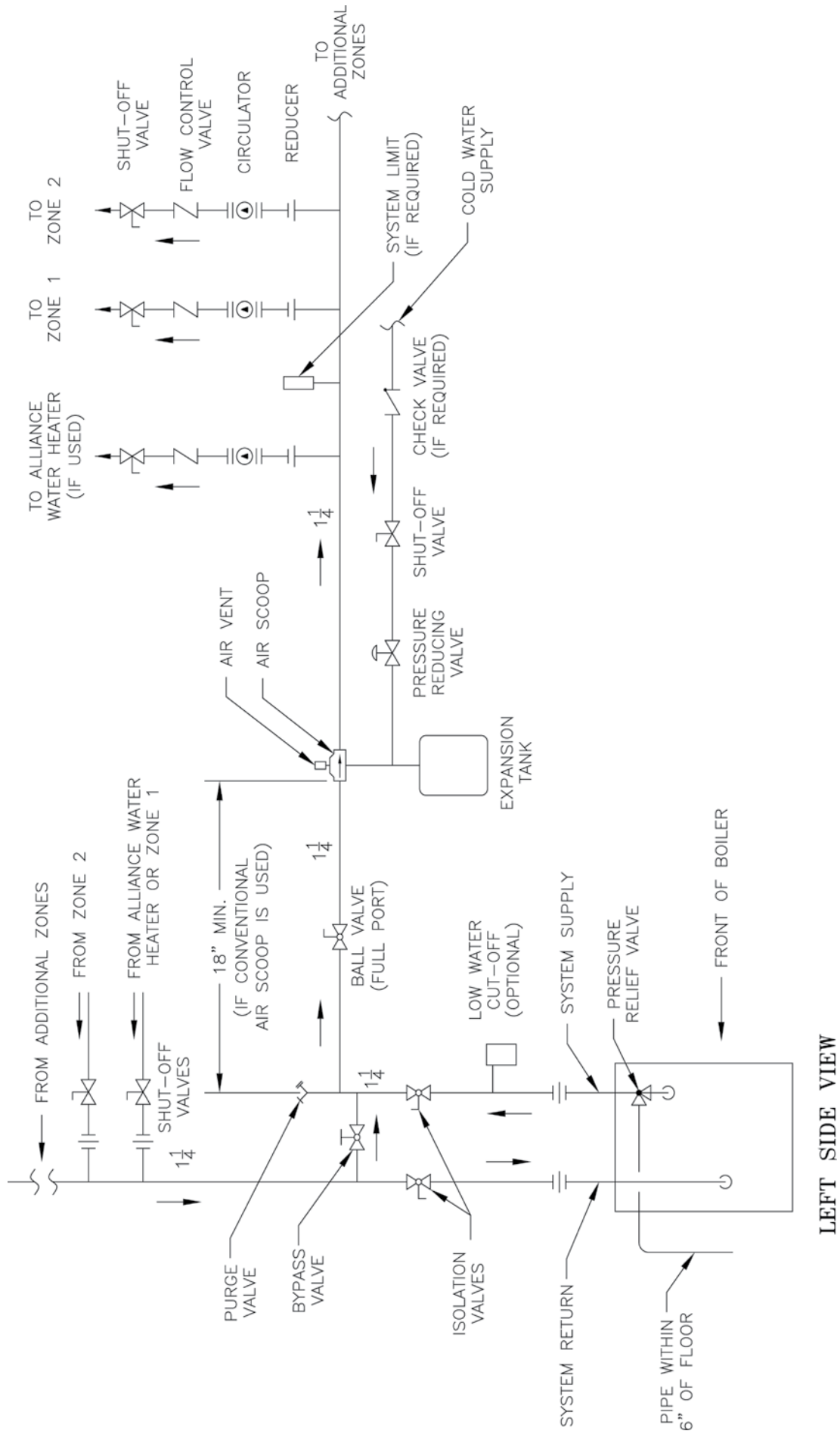

Figure 25: Recommended Water Piping for Circulator Zoned Heating Systems

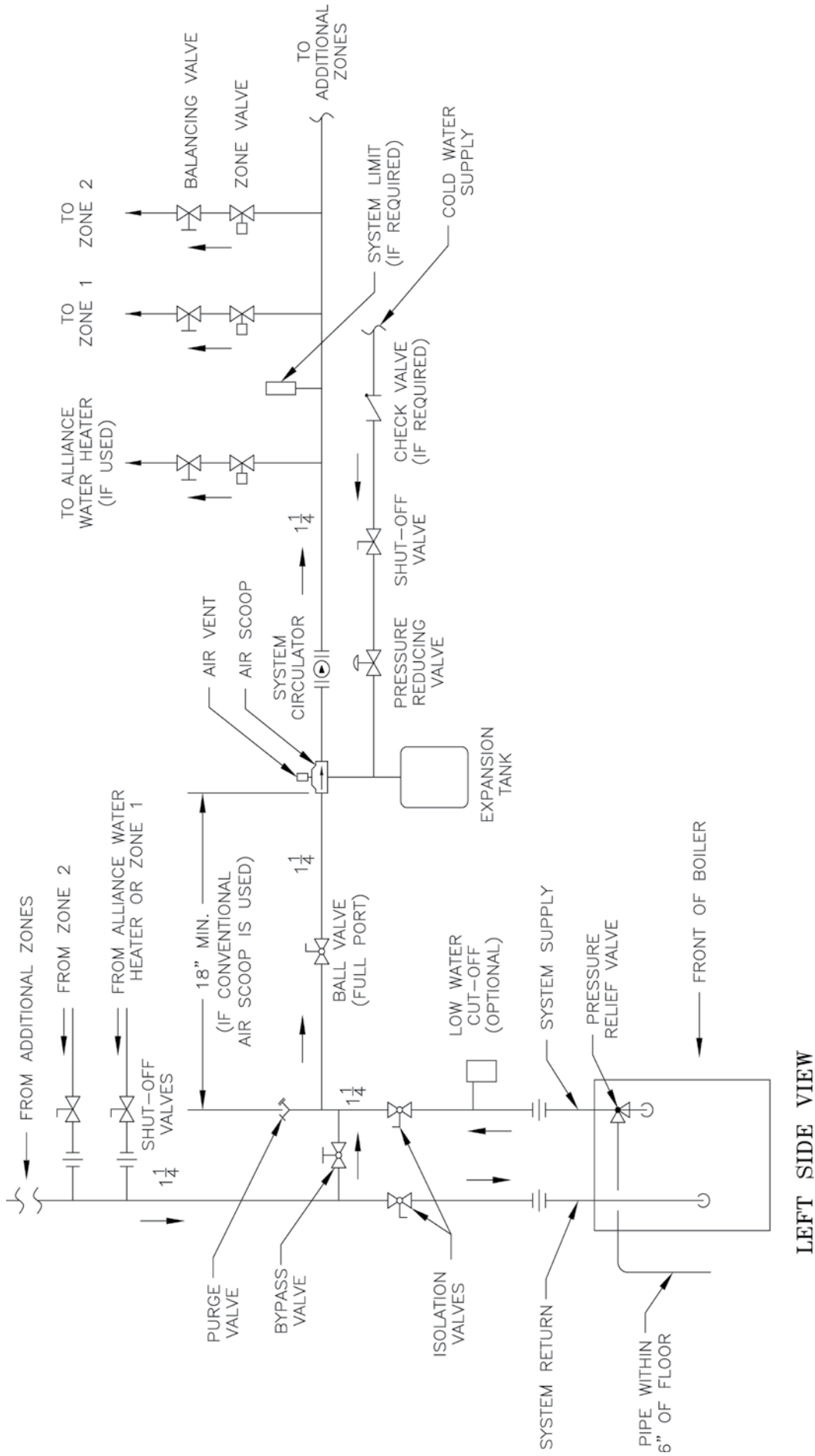

Figure 26: Recommended Water Piping for Zone Valve Zoned Heating Systems

V. Gas Piping

WARNING

Failure to properly pipe gas supply to boiler may result in improper operation and damage to the boiler or structure. Always assure gas piping is absolutely leak free and of the proper size and type for the connected load.

An additional gas pressure regulator may be needed. Consult gas supplier.

A. Size gas piping. Design system to provide adequate gas supply to boiler. Consider these factors:

1. Allowable pressure drop from point of delivery to boiler. Maximum allowable system pressure is $\frac{1}{2}$ psig. Actual point of delivery pressure may be less; contact gas supplier for additional information. Minimum gas valve inlet pressure is stamped on the rating label located in the boiler's vestibule compartment.
2. Maximum gas demand. Refer to the boiler's input as printed on its rating label. Also consider existing and expected future gas utilization equipment (i.e. water heater, cooking equipment).

3. Length of piping and number of fittings. Refer to Table 7 for maximum capacity of Schedule 40 pipe. Table 8 lists equivalent pipe length for standard fittings.
4. Corrections for the specific gravity of natural gas can be found in Table 6.

For materials or conditions other than those listed above, refer to *National Fuel Gas Code*, NFPA54/ANSI Z223.1, or size system using standard engineering methods acceptable to authority having jurisdiction.

TABLE 6: SPECIFIC GRAVITY CORRECTION FACTORS FOR NATURAL GAS

Specific Gravity	Correction Factor	Specific Gravity	Correction Factor
---	---	0.85	0.81
---	---	0.90	0.82
0.60	1.00	1.00	0.78
0.65	0.96	1.10	0.74
0.70	0.93	1.20	0.71
0.75	0.90	1.30	0.68
0.80	0.87	1.40	0.66

TABLE 5: GAS RATINGS

Boiler Model Number	Natural/LP Maximum Gas Pressure (in. w.c.)	Minimum Natural Gas Pressure (in. w.c.) Inlet to Gas Valve	Minimum LP Gas Pressure (in. w.c.) Inlet to Gas Valve	Natural Manifold Pressure (in. w.c.)	LP Manifold Pressure (in. w.c.)
SCG-3	14	4.5	11.5	3.5	10.5
SCG-4					
SCG-5					
SCG-6					
SCG-7					
SCG-8					
SCG-9					

NOTICE

SCG boilers built for altitudes greater than 4,999 feet above sea level need to be specially orificed to adjust for changes in atmospheric conditions. The SCG boiler "H" Model has been certified to operate in atmospheric conditions from 5,000 to 10,000 feet above sea level. Input is de-rated by 10% for applications at 5,000 feet above sea level, and 20% for applications at 10,000 feet above sea levels. De-rate is based on 2% reduction per 1000 feet.

The SCG boiler is available in two (2) altitude Models: The "S" Model 0 to 4,999 feet above sea level, and the "H" Model 5,000 to 10,000 feet above sea level.

For applications above 10,000 feet, consult the manufacturer.

TABLE 7: MAXIMUM CAPACITY OF SCHEDULE 40 PIPE IN CFH* FOR NATURAL GAS PRESSURES OF 0.5 PSIG OR LESS

Length [Feet]	0.3 Inch w.c. Pressure Drop				0.5 Inch w.c. Pressure Drop			
	½	¾	1	1¼	½	¾	1	1¼
10	132	278	520	1,050	175	360	680	1,400
20	92	190	350	730	120	250	465	950
30	73	152	285	590	97	200	375	770
40	63	130	245	500	82	170	320	660
50	56	115	215	440	73	151	285	580
60	50	105	195	400	66	138	260	530
70	46	96	180	370	61	125	240	490
80	43	90	170	350	57	118	220	460
90	40	84	160	320	53	110	205	430
100	38	79	150	305	50	103	195	400

* 1 CFH of Natural Gas is approximately equal to 1 MBH; 1 CFH of LP is approximately equal to 2.5 MBH; contact your gas supplier for the actual heating value of your gas.

B. Connect boiler gas valve to gas supply system.

WARNING

Failure to use proper thread compounds on all gas connectors may result in leaks of flammable gas.

WARNING

Gas supply to boiler and system must be absolutely shut off prior to installing or servicing boiler gas piping.

1. Use methods and materials in accordance with local plumbing codes and requirements of gas supplier. In absence of such requirements, follow *National Fuel Gas Code*, NFPA 54/ANSI Z223.1.
2. Use thread (joint) compounds (pipe dope) resistant to action of liquefied petroleum gas.
3. Install sediment trap, ground-joint union and manual shut-off valve upstream of boiler gas control valve and outside jacket. See Figure 27.

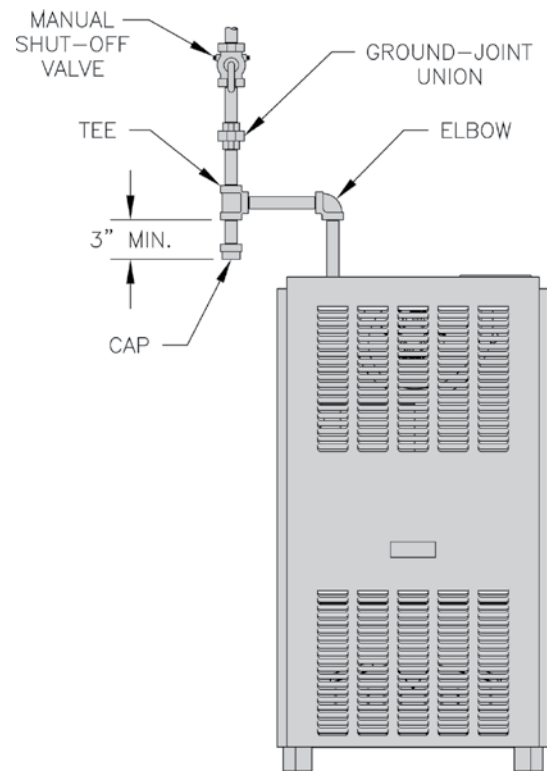

Figure 27: Recommended Gas Piping

TABLE 8: EQUIVALENT LENGTHS OF STANDARD PIPE FITTINGS & VALVES

VALVES FULLY OPEN									
Pipe Size	I.D. Inches	Gate	Globe	Angle	Swing Check	90° Elbow	45° Elbow	90° Tee, Flow Through Run	90° Tee, Flow Through Branch
½"	06.22	0.35	18.6	9.3	4.3	1.6	0.78	1.0	3.1
¾"	0.824	0.44	23.1	11.5	5.3	2.1	0.97	1.4	4.1
1"	1.049	0.56	29.4	14.7	6.8	2.6	1.23	1.8	5.3
1¼"	1.380	0.74	38.6	19.3	8.9	3.5	1.60	2.3	6.9

4. All above ground gas piping upstream from manual shut-off valve must be electrically continuous and bonded to a grounding electrode. Do not use gas piping as grounding electrode. Refer to *National Electrical Code*, NFPA 70.

C. Pressure test. The boiler and its gas connection must be leak tested before placing boiler in operation.

1. Protect boiler gas control valve. For all testing over ½ psig, boiler and its individual shutoff valve must be disconnected from gas supply piping. For testing at ½ psig or less, isolate boiler from gas supply

piping by closing boiler's individual manual shutoff valve.

2. Locate leaks using approved combustible gas detector, soap and water, or similar nonflammable solution.

DANGER

Do not use matches, candles, open flames or other ignition source to check for leaks.

VI. Electrical

DANGER

Positively assure all electrical connections are unpowered before attempting installation or service of electrical components or connections of the boiler or building. Lock out all electrical boxes with padlock once power is turned off.

WARNING

Failure to properly wire electrical connections to the boiler may result in serious physical harm.

Electrical power may be from more than one source. Make sure all power is off before attempting any electrical work.

Each boiler must be protected with a properly sized over-current device.

Never jump out or make inoperative any safety or operating controls.

The wiring diagrams contained in this manual are for reference purposes only. Each boiler is shipped with a wiring diagram attached to the front door. Refer to this diagram and the wiring diagram of any controls used with the boiler. Read, understand and follow all wiring instructions supplied with the controls.

A. General. Install wiring and electrically ground boiler in accordance with authority having jurisdiction or, in the absence of such requirements, follow the *National Electrical Code*, NFPA 70, and/or CSA C22.1 Electrical Code.

B. A separate electrical circuit must be run from the main electrical service with an over-current device/disconnect in the circuit. A service switch is recommended and may be required by some local jurisdictions. Install the service switch in the line voltage “Hot” leg of the power supply. Locate the

service switch such that the boiler can be shut-off without exposing personnel to danger in the event of an emergency. Connect the main power supply and ground to the three (3) boiler wires (black, white and green) located in the junction box at the inside top of the boiler jacket. If a low water cutoff is to be used, connect the low water cutoff so that all 120V power to boiler is interrupted if the low water cutoff’s switch opens.

C. Refer to Figures 28 and 29 for details on the internal boiler wiring.

NOTICE

This boiler is equipped with a high water temperature limit located inside the internal wiring of the boiler. This limit provides boiler shutdown in the event the boiler water temperature exceeds the set point of the limit control. Certain Local Codes require an additional water temperature limit. In addition, certain types of systems may operate at temperatures below the minimum set point of the limit contained in the boiler.

If this occurs, install an additional water temperature limit (Honeywell L4006 Aquastat) located in the system piping as shown in the Water Piping and Trim Section of this manual. Wire as indicated in the Electrical Section of this manual.

NOTICE

All wire, wire nuts, controls etc. are installer supplied unless otherwise noted.

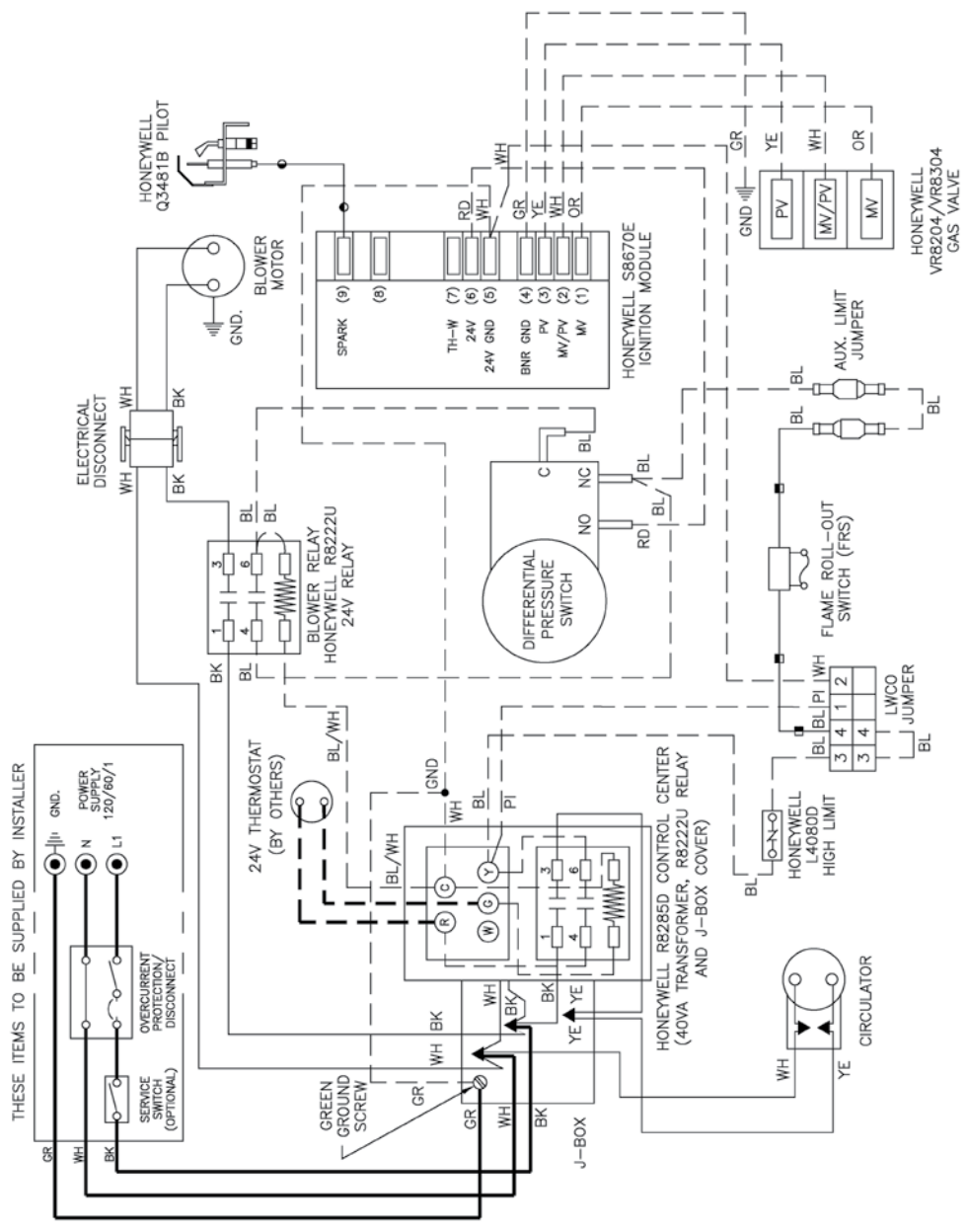

SCHEMATIC DIAGRAM LEGEND

- LOW VOLTAGE SIZE 18 AWG WIRE TYPE TW/AWM STRANDED WIRE - 105° C
- LOW VOLTAGE SIZE 18/2 AWG POWER LIMITED CIRCUIT CABLE - 75-105° C
- LINE VOLTAGE SIZE 18 AWG WIRE TYPE TW OR TEW/AWM
- LINE VOLTAGE SIZE 14 AWG WIRE TYPE TW
- HONEYWELL IGNITION/SENSOR CABLE - 250° C
- CONTINENTAL SRGX600 18 AWG WIRE TYPE SF-2/SEW-2, 200°C, STRANDED,
- 3/4" THICK INSULATION

NOTES:

1. IF ANY OF THE ORIGINAL WIRE, AS SUPPLIED WITH THE APPLIANCE, MUST BE REPLACED, IT MUST BE REPLACED WITH WIRE ITS EQUIVALENT.
SI UN DES CONDUCTEURS FOURNI AVEC L'APPAREIL DOIT ÊTRE REMPLACÉ UTILISER UN CONDUCTEUR DE OU L'ÉQUIVALENT.
2. HONEYWELL SB670E IGNITION MODULE CAN ONLY BE REPLACED WITH MODULE HAVING 30 SECONDS MINIMUM PREPURGE FEATURE.
3. WHEN CONNECTING FIELD WIRING TO THE BOILER, WIRING MATERIAL HAVING A MINIMUM SIZE OF 18 AWG AND A TEMPERATURE RATING OF AT LEAST 105°C/221°F SHALL BE USED.
UTILISER DES CONDUCTEURS DE SECTION ÉGALE OU SUPÉRIEURE À 18 AWG, CONVARIANT À AU MOINS 105°C (221°F) POUR LES RACCORDEMENTS A PIED D'ŒUVRE À LA CHAUDIÈRE.

Figure 28: Internal Boiler Wiring Schematic Diagram

NOTICE

If an additional system limit is used, install in series with the auxiliary limit jumper shown in the drawing below.

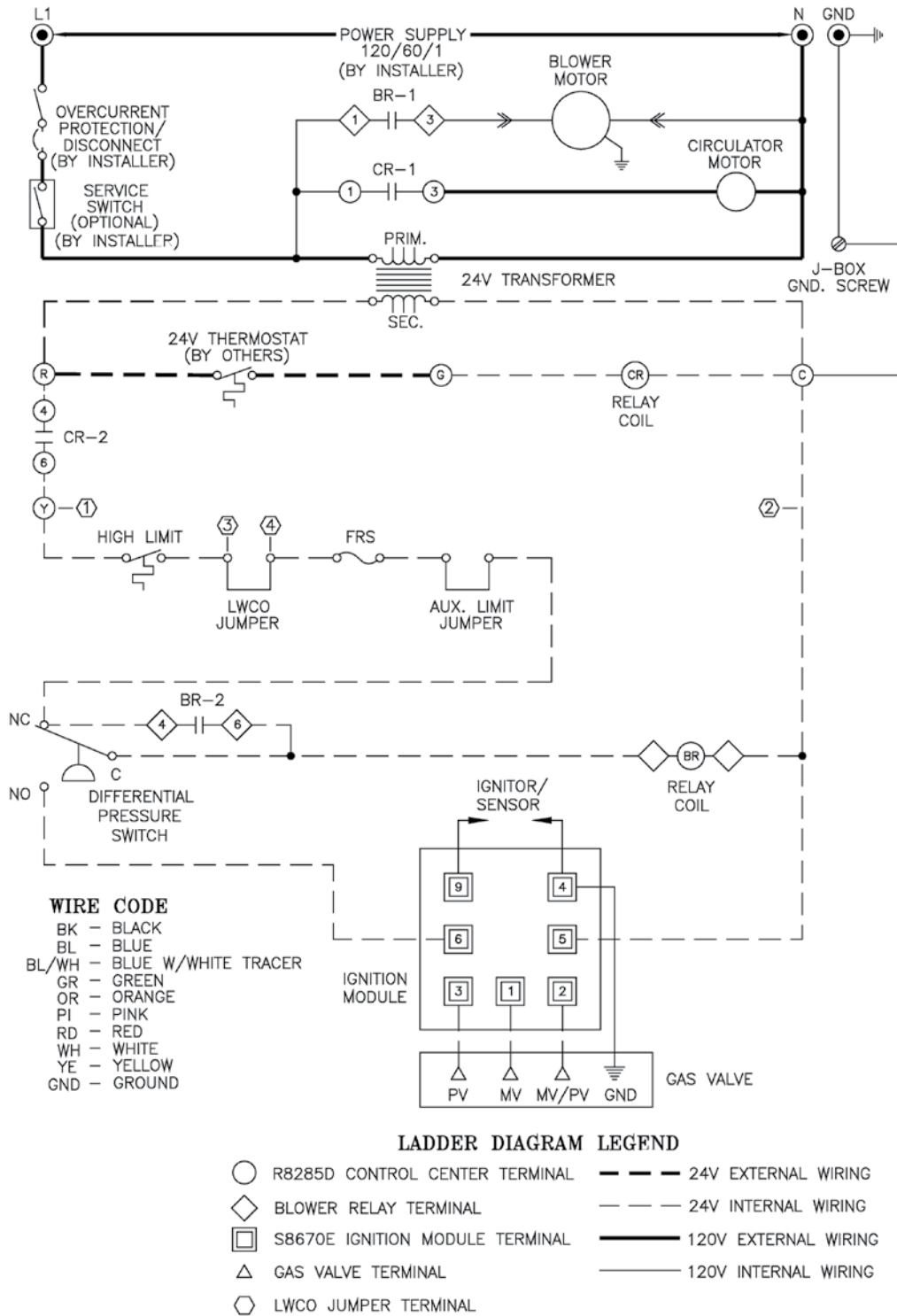

Figure 29: Internal Boiler Wiring Ladder Diagram

D. System Controls and Wiring

1. Refer to National Electric Code or Local Electric Codes for proper size and type of wire required. Follow Code.
2. Use anti-short bushings on all wiring passing through boiler jacket, junction boxes and/or control boxes.
3. Use armored cable (BX) over all exposed line voltage wiring.
4. If an Alliance SL™ indirect water heater is used, use priority zoning except for Hydro-Air Systems.
5. Single Zone Heating System – Refer to Figure 30 of this manual for the electrical diagram for this type of system.
Set the thermostat heat anticipator to 0.60 amps.
6. Single Zone Heating System with Alliance SL™ Water Heater - Refer to Figure 31 of this manual for the electrical diagram for this type of system.
Set the thermostat heat anticipator to 0.60 amps.
7. Conventional Circulator Zoned System – Refer to Figure 32 of this manual for the electrical diagram for this type of system.
Read, understand and follow all of the instructions provided with the Honeywell R8888 control.
Connect the thermostat of each zone and the circulator for that zone to R8888 panel. If an Alliance SL™ indirect water heater is used, connect the Alliance SL™ thermostat and circulator to the Zone 1 terminals of the R8888.
Set the thermostat heat anticipator to 0.12 amps.

NOTICE

The Honeywell R8888 Control is available in a three (3) zone Model (R8888A) and a four (4) zone Model (R8888B). Up to four (4) R8888's may be used together to provide control for up to twelve (12) individual zones. Only one (1) zone, the first zone of the main control, will provide priority circulation. If more than four (4) zones are required, connect additional R8888's by wiring the A, B, and C terminals of each control together. Each R8888 requires a 120 volt power supply. If more than one (1) R8888 is used, set the panel type switch to "main" on the first R8888 and set the panel type switch to "expansion" on the second, third or fourth R8888.

8. Conventional Zone Valve Zoned System – Refer to Figure 33. Wiring to the most popular models of zone valves is given in Figure 34.
Connect the thermostat of each zone and the zone valve for that zone to the R8889 control. If an Alliance SL™ indirect water heater is used, connect the Alliance SL™ thermostat and zone valve to the "zone 1" terminals of the R8889.
Set the thermostat heat anticipator to 0.12 amps.

NOTICE

The Honeywell R8889 Control is available in two three (3) zone models and two four (4) zone models. U.S. Boiler recommends using Model R8889A for three (3) zone systems and Model R8889B for four (4) zone systems. Models R8889C and R8889D have less load capacity and may not operate with certain types of zone valves. Up to four (4) R8889's may be used together to provide up to sixteen (16) individual zones. Only one (1) zone, the first zone of the main control will provide priority zoning for the Alliance SL™ indirect water heater. If more than four (4) zones are required, connect additional R8889's by wiring the A, B and C terminals of each control together. Each R8889 requires a 120 volt power supply. If more than one (1) R8889 is used, set the panel type switch to "main" on the first R8889 and set the panel type switch to "expansion" on the second, third or fourth R8889.

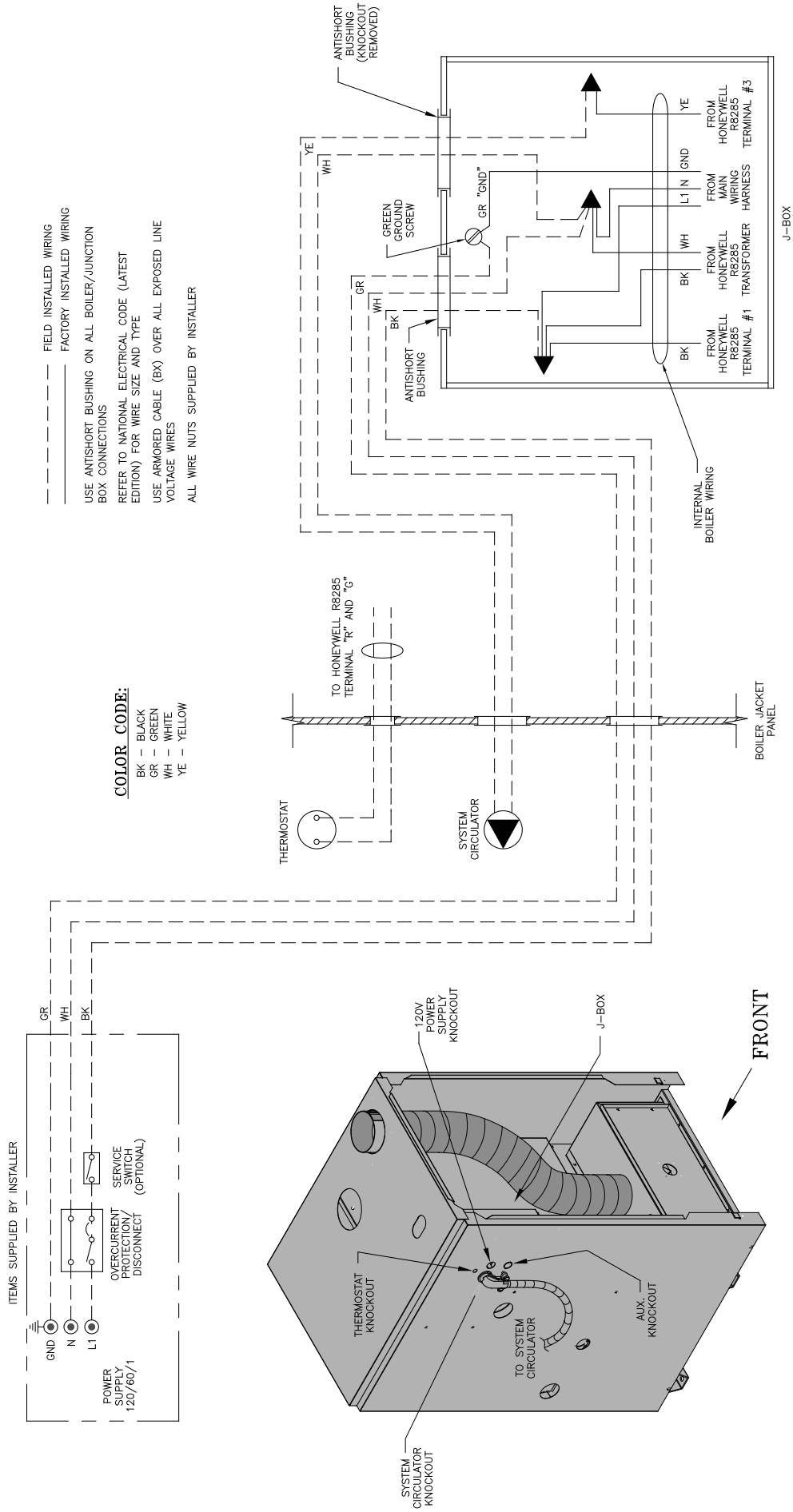
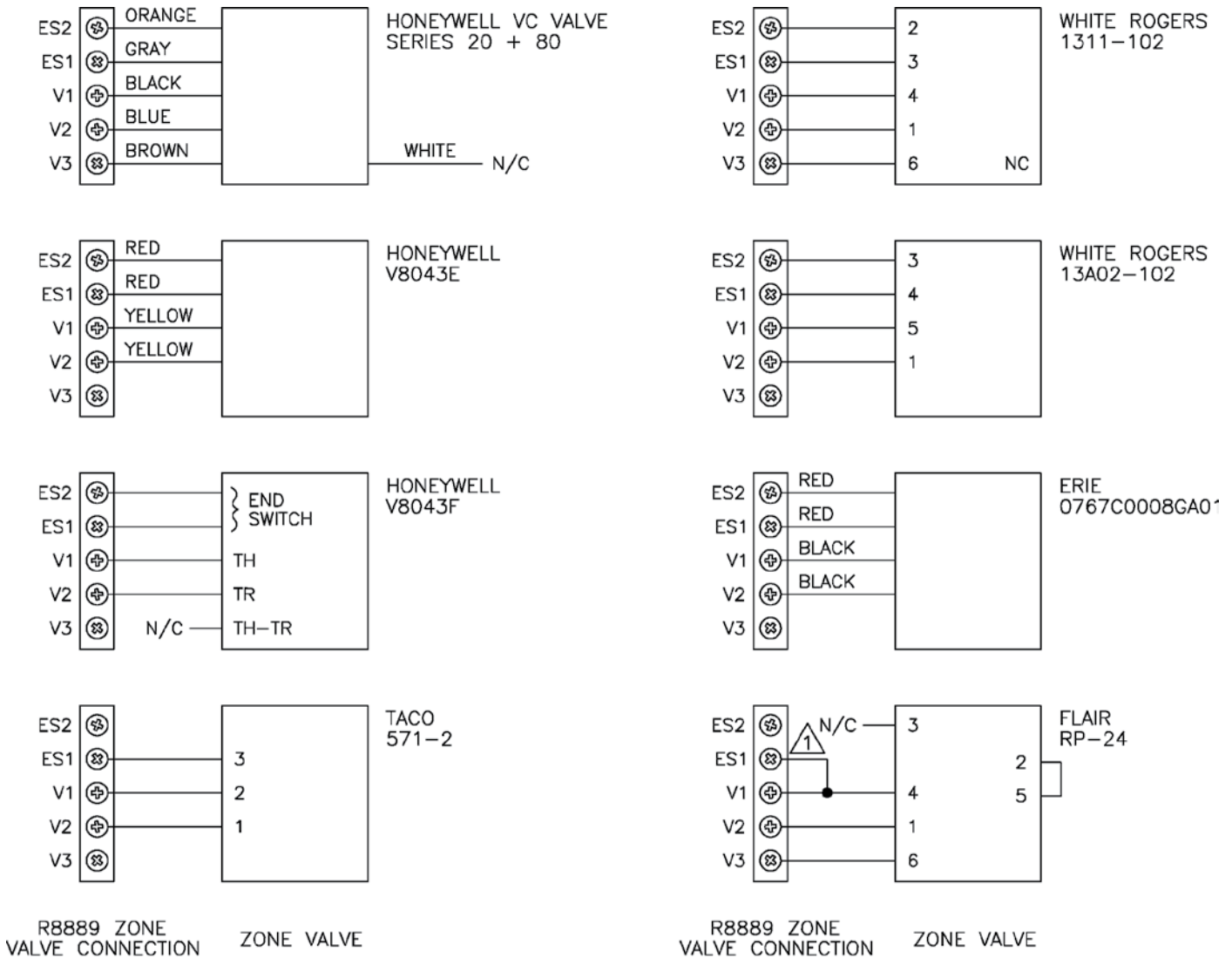

Figure 30: System Wiring Schematic for Single Zone Space Heating Only



1 JUMPER V1 TO ES1 WHEN USING ZONE VALVES WITHOUT END SWITCHES.

Figure 34: Different Manufacturer's Zone Valve Connections to Honeywell R8889

VII. Modular Installation

A. General Guidelines

1. Read and follow all venting, combustion air, water piping, gas piping and electrical instructions contained in this manual unless otherwise instructed in this section.
2. Consult Local Building Codes or National Fuel Gas Code, NFPA 54/ANSI Z222.3 for restrictions and instructions on modular boiler installations.

B. Module Sizing

U.S. Boiler recommends sizing each boiler in a modular system to provide 20 % of the combined heating load where ever possible.

C. Venting

1. Each boiler must have an individual vent pipe. Refer to Venting Section of this manual for venting guidelines and options.

WARNING

Do not manifold vent pipes together.

2. The maximum vent length for each boiler is fifty (50) equivalent feet.
3. The minimum horizontal distance between vent terminations is one (1) foot. Additional horizontal distance is desirable to avoid frost damage to the building. Vent terminations must be at least twelve (12) inches above the ground plus the expected snow accumulation.

CAUTION

Installing multiple vent terminations close together promotes frost buildup on buildings. To minimize this possibility, extend the distance from the building to the end of the vent termination and increase the horizontal distance between terminations.

4. Multiple vertical vent pipes may be piped through a common conduit or chase so that one roof penetration may be made. Each vent termination must be one (1) foot from other terminations.

D. Air Intake Piping

1. Each boiler must have an individual air intake pipe, refer to Venting Section of this manual for Air Intake Guidelines and Options.
2. The maximum air intake length for each boiler is fifty (50) equivalent feet.
3. Locate air intake termination on the same wall as the vent termination if possible, to prevent nuisance boiler shutdowns. However, boiler may be installed with vertical venting and sidewall combustion air

inlet (or visa versa) if installation conditions do not allow alternate arrangement.

TABLE 9: MODULAR BOILER WATER MANIFOLD SIZING

Combined Output (MBH)	Recommended Minimum Common Water Manifold Size (NPT)
≤ 166	1¼"
≤ 260	1½"
≤ 550	2"
≤ 900	2½"
≤ 2000	3"

E. Water Piping (See Table 9)

Installing a low water cutoff in the system piping of modular systems is strongly recommended and may be required by Local Codes.

F. Gas Piping

1. Refer to National Fuel Gas Code, Local Codes and Tables 7 and 8 for gas pipe sizing.
2. Each boiler must be piped as shown in Figure 27.

WARNING

If gas pressure in the building is above ½ psig, an additional gas pressure regulator is required. Using one additional regulator for multiple boilers may result in unsafe boiler operation. The additional regulator must be able to properly regulate gas pressure at the input of the smallest boiler. If the regulator cannot do this, two or more additional regulators are required. Consult regulator manufacturer and/or local gas supplier for instructions and equipment ratings.

G. Electrical

1. Each boiler must be provided with a fused disconnect and service switch.
2. Install wiring in accordance with requirements of authority having jurisdiction. In the absence of such requirements, follow the National Electric Code, NFPA 70 and/or CSA C22.1 Electric Code.

H. Modular Boiler Control Systems

Contact a controls manufacturer such as Honeywell or Tekmar to properly apply a modular control system.

Common systems may use outdoor temperature, return water temperature or both to stage the boilers.

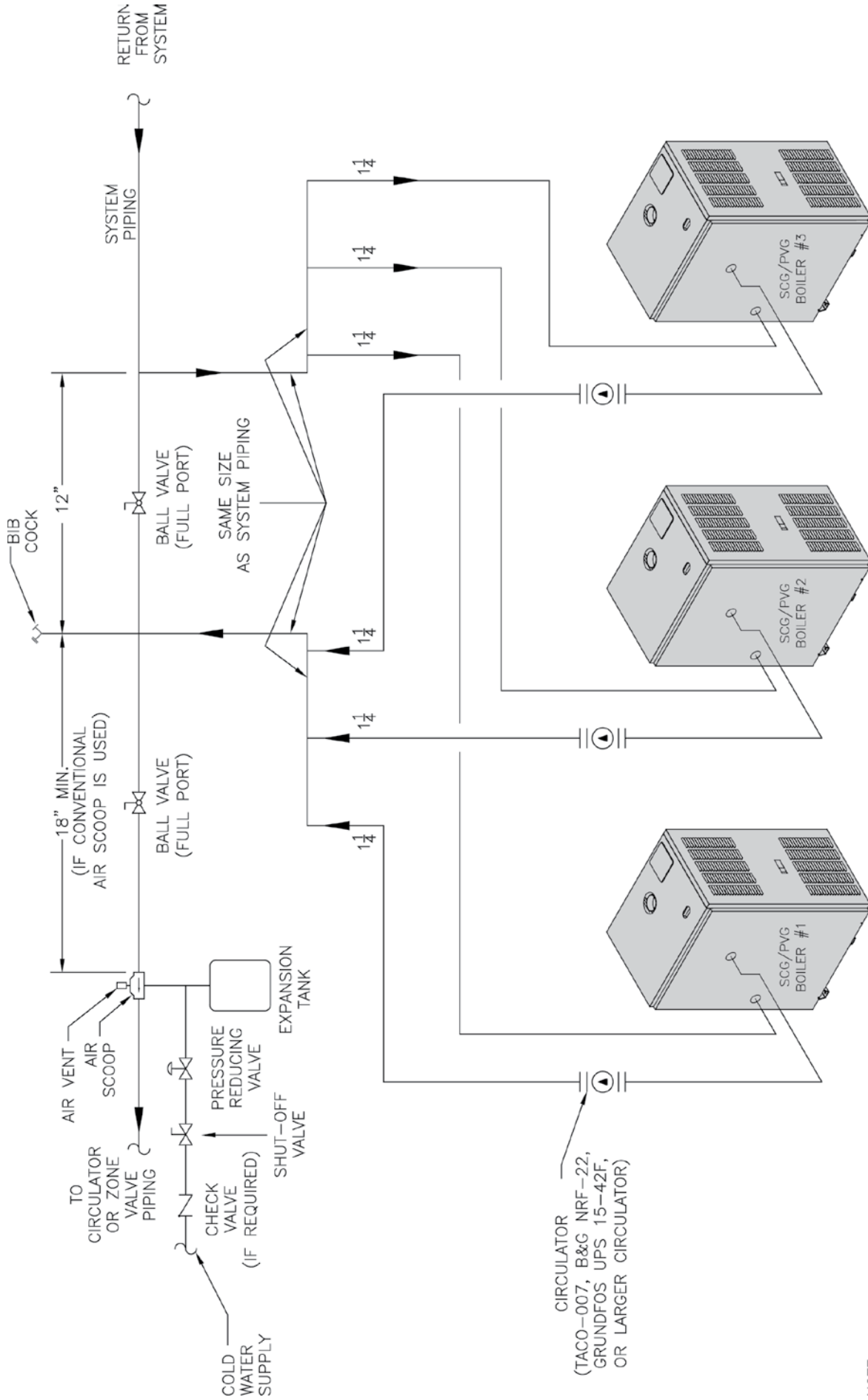

NOTE:
 1. MAINTAIN MINIMUM PIPING TO EQUALIZE SUPPLY AND RETURN PIPE LENGTHS. INSTALL BALANCING VALVE TO EQUALIZE FLOW.

Figure 35: Modular Boiler Gas Piping

VIII. System Start-up

- A. Safe operation** and other performance criteria were met with gas manifold and control assembly provided on boiler when boiler underwent tests specified in *American National Standard for Gas-Fired Low-Pressure Steam and Hot Water Boilers*, ANSI Z21.13.
- B.** Verify that the venting, water piping, gas piping and electrical system are installed properly. Refer to installation instructions contained in this manual.
- C. Confirm** all electrical, water and gas supplies are turned off at the source and that vent is clear of obstructions.
- D. Confirm** that all manual shut-off gas valves between the boiler and gas source are closed.

WARNING

Completely read, understand and follow all instructions in this manual before attempting start up.

- E. Fill entire heating system with water** and vent air from system. Use the following procedure on a Series Loop or multi-zoned system installed as per Figure 25 or 26 to remove air from system when filling.

WARNING

The maximum operating pressure of this boiler is 30 psig. Never exceed this pressure. Do not plug or change pressure relief valve.

NOTICE

If it is required to perform a long term pressure test of the hydronic system, the boiler should first be isolated to avoid a pressure loss due to the escape of air trapped in the boiler.

To perform a long term pressure test including the boiler, ALL trapped air must first be removed from the boiler.

A loss of pressure during such a test, with no visible water leakage, is an indication that the boiler contained trapped air.

1. Close full port ball valve in boiler supply piping.
2. Isolate all zones by closing zone valves or shut-off valves in supply and return of each zone(s).
3. Attach a hose to the vertical hose bib located prior to the full port ball valve in the system supply piping. (Note - Terminate hose in five gallon bucket at a suitable floor drain or outdoor area).
4. Starting with one circuit at a time, open zone valve

- or shut-off valve in system supply and return piping.
5. Open hose bib.
6. Open fill valve (Make-up water line should be located directly after full port ball valve in system supply piping between air scoop and expansion tank).
7. Allow water to overflow from bucket until discharge from hose is bubble free for 30 seconds.
8. Close the opened zone valve or shut-off valve for the zone being purged of air, then open the zone valve or shut-off valve for the next zone to be purged. Repeat this step until all zones have been purged. At completion, open all zone valves or shut-off valves.
9. Close hose bib, continue filling the system until the pressure gauge reads 12 psi. Close fill valve.
(Note - If make-up water line is equipped with pressure reducing valve, system will automatically fill to 12 psi. Follow fill valve manufacturer's instructions).
10. Open isolation valve in boiler supply piping.
11. Remove hose from hose bib.

- F. Confirm that the boiler and system have no water leaks.**

- G. Prepare to check operation.**

1. Obtain gas heating value (in Btu per cubic foot) from gas supplier.
2. Connect manometer to pressure tap on gas valve. Use 1/8 NPT tapping provided.
3. Temporarily turn off all other gas-fired appliances.
4. Turn on gas supply to the boiler gas piping.
5. Confirm that the supply pressure to the gas valve is 14 in. w.c. or less. Refer to Table 5 for minimum supply pressure.
6. Open the field installed manual gas shut-off valve located upstream of the gas valve on the boiler.
7. Using soap solution, or similar non-combustible solution, electronic leak detector or other approved method. Check that boiler gas piping valves, and all other components are leak free. Eliminate any leaks.

DANGER

Do not use matches, candles, open flames or other ignition source to check for leaks.

8. Purge gas line of air.

FOR YOUR SAFETY READ BEFORE OPERATING

WARNING: If you do not follow these instructions exactly, a fire or explosion may result causing property damage, personal injury, or loss of life.

- A. This appliance is equipped with an ignition device which automatically lights the pilot. Do not try to light the pilot by hand.
- B. **BEFORE OPERATING** smell all around the appliance area for gas. Be sure to smell next to the floor because some gas is heavier than air and will settle on the floor.

WHAT TO DO IF YOU SMELL GAS

- ▶ Do not try to light any appliance.
- ▶ Do not touch any electric switch; do not use any phone in your building.
- ▶ Immediately call your gas supplier from a neighbor's phone. Follow the gas supplier's instructions.

▶ If you cannot reach your gas supplier, call the fire department.

- C. Use only your hand to push in or turn the gas control knob. Never use tools. If the knob will not push in or turn by hand, don't try to repair it, call a qualified service technician. Force or attempted repair may result in a fire or explosion.
- D. Do not use this appliance if any part has been under water. Immediately call a qualified service technician to inspect the appliance and to replace any part of the control system and any gas control which has been under water.

OPERATING INSTRUCTIONS

1. **STOP!** Read the safety information above on this label.
2. Set the thermostat to lowest setting.
3. Turn off all electric power to the appliance.
4. This appliance is equipped with an ignition device which automatically lights the pilot. Do not try to light the pilot by hand.
5. Remove front door.
6. Locate the gas control valve at the end of the gas supply pipe going into the boiler. The gas control knob is the brown or blue plastic knob located on top of the gas control valve.

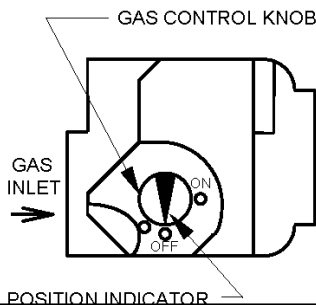

7. Rotate gas control knob clockwise from "ON" position to "OFF". Make sure knob rests against stop.
8. Wait five (5) minutes to clear out any gas. Then smell for gas, including near the floor. If you smell gas, **STOP!** Follow "B" in the safety information above on this label. If you do not smell gas, go to the next step.
9. Rotate gas control knob counterclockwise from "OFF" to "ON". Make sure knob rest against stop. Do not force.
10. Replace front door.
11. Turn on all electric power to the appliance.
12. Set thermostat to desired setting.
13. If the appliance will not operate, follow the instructions "TO TURN OFF GAS TO APPLIANCE" and call your service technician or gas supplier.

TO TURN OFF GAS TO APPLIANCE

1. Set the thermostat to lowest setting.
2. Turn off all electric power to the appliance if service is to be performed.
3. Remove front door.
4. Rotate gas control knob clockwise from "ON" position to "OFF". Make sure knob rests against stop.
5. Replace front door.

31460 47

Figure 36: Operating Instructions

H. Operating Instructions.

1. Follow Operating Instructions to place boiler in operation. See Figure 36.
2. Enhanced Electronic Ignition Module with single Status LED indicator. See Figure 37A “Location of LED”.

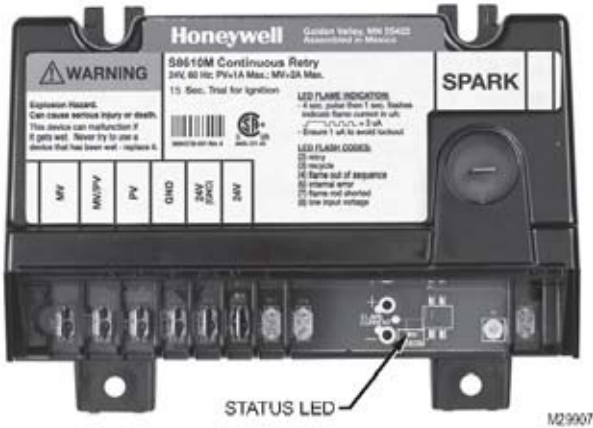

Figure 37A: Location of LED

Table 10 cross-references the ignition module terminal designations to the ignition terminal numbers in the wiring ladder diagrams.

Table 11 provides green LED status codes and recommended service action where applicable.

3. Flame Current Measurement Procedure. See Figure 37B . “Measuring pilot flame current with micro-ammeter”

TABLE 10: IGNITION MODULE TERMINAL CROSS-REFERENCE

Ignition Module Terminal Designation	Wiring Ladder Diagram Terminal Number
MV	1
MV/PV	2
PV	3
GND	4
24V (GND)	5
24V	6
SPARK	9

- a. Pilot flame current in micro amps can be measured using any standard micro-ammeter by inserting the meter probes into the module holes labeled FLAME CURRENT as shown in Figure 37B.
- b. Flame current **must be measured with pilot valve open/pilot lit but the main valve closed.**
- c. Disconnect MV lead wire from the module before measuring flame current. Trying to measure the pilot flame current in series with the wiring will not yield the accurate reading.
- d. The **minimum steady pilot flame signal must be 1 μ Amp** (microampere) DC (direct current).
- e. **For reliable operation** the flame current should be **2 μ Amp or greater.**
- f. To ensure **adequate flame current:**
 - i. Turn off boiler power at circuit breaker or fuse box

Figure 37B: Measuring Pilot Flame Current with Micro-ammeter

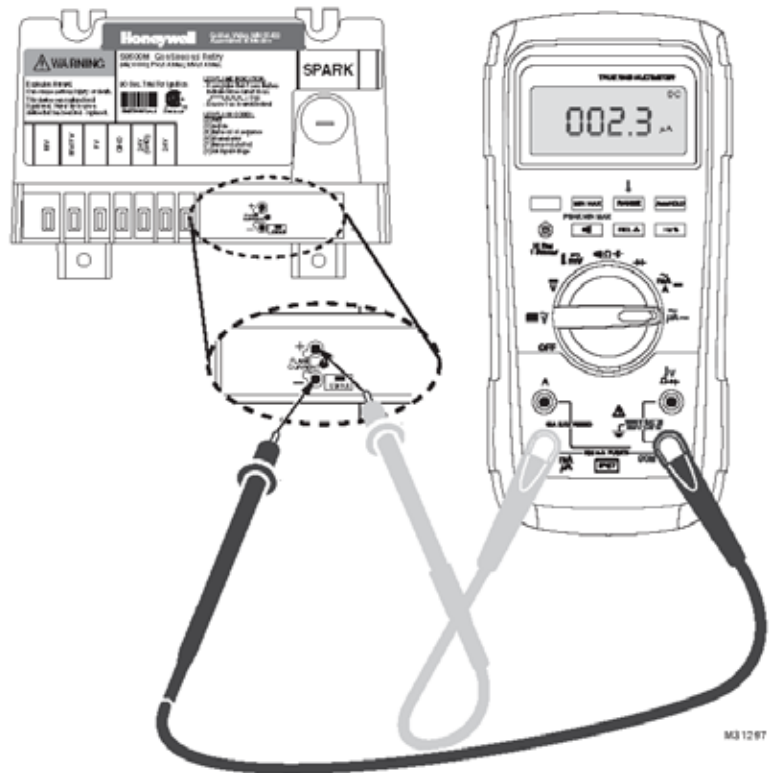

- ii. Clean the flame rod with emery cloth if required
- iii. Make sure electrical connections are clean and tight, and wiring not damaged, repair/replace as needed
- iv. Check for igniter/sensor cracked ceramic insulator, replace if needed
- v. Check the pilot flame. It must be blue, steady and envelop the flame sensing rod 3/8" to 1/2".
- vi. If needed, adjust pilot flame by turning the gas valve pilot adjustment screw clockwise to decrease or counterclockwise to increase pilot flame. Always reinstall pilot adjustment screw cover and tighten securely upon completion to assure proper gas valve operation.
- g. Reconnect MV lead wire to the module upon satisfactory completion of pilot flame current measurement.
- h. Check the pilot burner operation/ignition sequence during ignition cycle:
 - i. Restore boiler power at circuit breaker or fuse box.
 - ii. Set thermostat to call for heat.
 - iii. Watch ignition sequence at burner.
 - iv. If spark does not stop after pilot lights, replace ignition module.
 - v. If main burners do not light or if main burners light but system locks out, check the module ground wire and gas control as described in Figure 38 "Honeywell Electronic Ignition Troubleshooting Guide".

TABLE 11: GREEN LED STATUS CODES

Green LED Flash Code ^a	Indicates	Next System Action	Recommended Service Action
OFF	No "Call for Heat"	N/A	None
Flash Fast	Power up - internal check	N/A	None
Heartbeat	Normal startup - ignition sequence started (including prepurge)	N/A	None
4 Seconds ON then "x" flashes	Device in run mode. "x" = flame current to the nearest μ A.	N/A	None
2	5 minute Retry Delay - Pilot flame not detected during trial for ignition	Initiate new trial for ignition after retry delay completed.	If system fails to light on next trial for ignition check gas supply, pilot burner, spark and flame sense wiring, flame rod contamination or out of position, burner ground connection.
3	Recycle - Flame failed during run	Initiate new trial for ignition. Flash code will remain through the ignition trial until flame is proved.	If system fails to light on next trial for ignition, check gas supply, pilot burner, flame sense wiring, contamination of flame rod, burner ground connection.
4	Flame sensed out of sequence	If situation self corrects within 10 seconds, control returns to normal sequence. If flame out of sequence remains longer than 10 seconds, control will resume normal operation 1 hour after error is corrected.	Check for pilot flame. Replace gas valve if pilot flame present. If no pilot flame, cycle "Call for Heat." If error repeats, replace control.
6	Control Internal Error	Control remains in wait mode. When the fault corrects, control resumes normal operation.	Cycle "Call for Heat". If error repeats, replace control.
7	Flame rod shorted to ground	Control remains in wait mode. When the fault corrects, control resumes normal operation.	Check flame sense lead wire for damage or shorting. Check that flame rod is in proper position. Check flame rod ceramic for cracks, damage or tracking.
8	Low secondary voltage supply- (below 15.5 Vac)	Control remains in wait mode. When the fault corrects, control resumes normal operation.	Check transformer and AC line for proper input voltage to the control. Check with full system load on the transformer.

^aFlash Code Descriptions:

- Flash Fast: rapid blinking
- Heartbeat: Constant 1/2 second bright, 1/2 second dim cycles.
- 4 second solid on pulse followed by "x" 1 second flashes indicates flame current to the nearest μ A. This is only available in run mode.
- A single flash code number signifies that the LED flashes X times at 2Hz, remains off for two seconds, and then repeats the sequence.

Honeywell Electronic Ignition Troubleshooting Guide

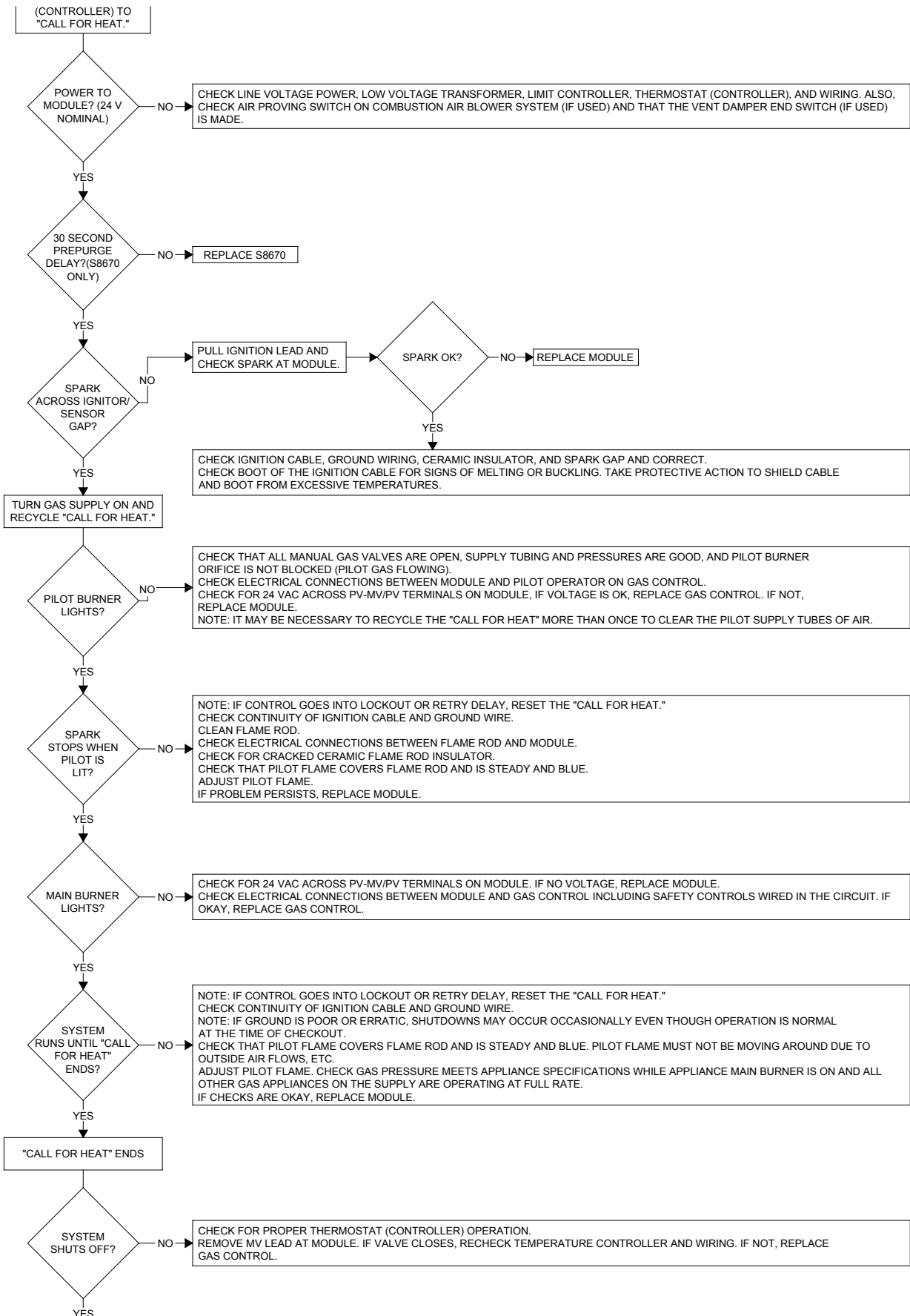

Figure 38: Troubleshooting Guide

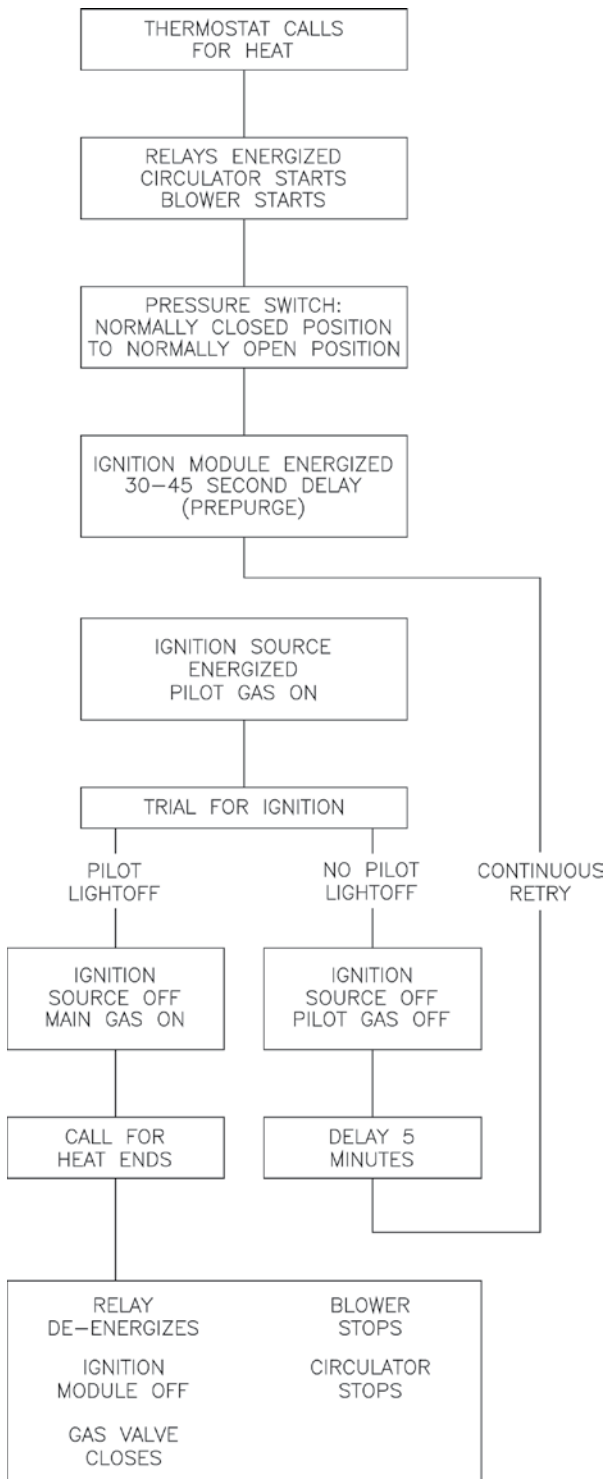

Figure 39: Sequence of Operation

- I. Sequence of Operation.** See Figure 39. If boiler fails to operate properly, see Troubleshooting Tree in Section IX: Service.
- J. Check pilot burner flame.** See Figure 41. Flame should be steady, medium hard blue enveloping 3/8 to 1/2 inch of sensing probe.
- K. Check main burner flame.** See Figures 40. Flame should have clearly defined inner cone with no yellow

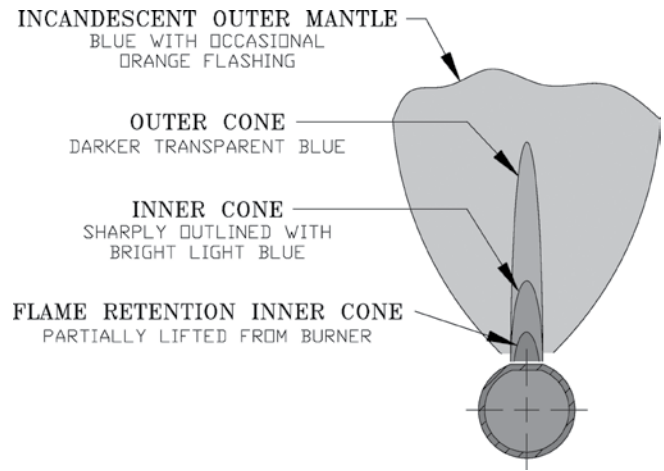

Figure 40: 1 Inch Main Burner flame

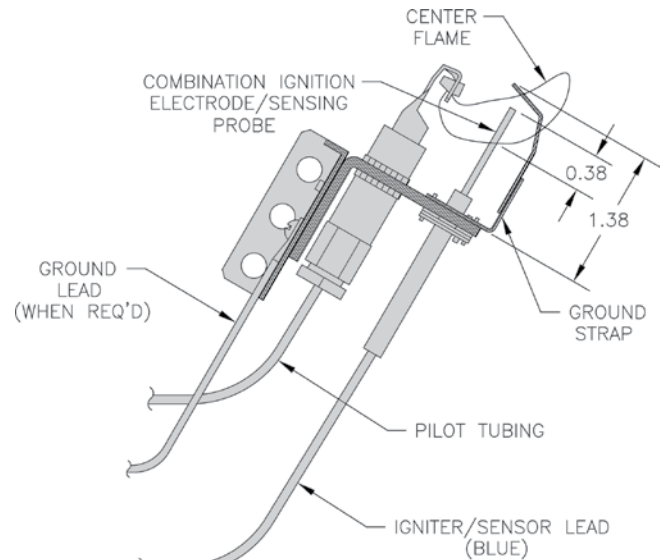

Figure 41: Pilot Burner Flame

tipping. Orange-yellow streaks should not be confused with true yellow tipping.

- L. Check thermostat operation.** Raise and lower temperature setting to start and stop boiler operation.
- M. Check ignition control module shut-off.** Disconnect pilot lead wires from gas valve. If burners do not shutdown, determine cause of malfunction. Replace necessary items and check operation.
- N. Check low water cutoff** (if so equipped).
 1. Adjust thermostat to highest setting.
 2. With boiler operating, open drain valve and slowly drain boiler.
 3. Main burners and pilot burner will extinguish and blower will stop when water level drops below low water cutoff probe. Verify limit, thermostat or other controls have not shut off boiler.
 4. Adjust thermostat to lowest setting. Refill boiler.

O. Check limit.

1. Adjust thermostat to highest setting.
2. Observe temperature gauge. When temperature is indicated, adjust limit to setting below observed temperature. Main burners and pilot burner should extinguish, and blower should stop.
3. Adjust limit to setting above observed temperature. Ignition sequence should begin.
4. Adjust thermostat to lowest setting. Adjust limit to desired setting.

P. Adjust gas input rate to boiler.

1. Adjust thermostat to highest setting.
2. Check manifold gas pressure. See Table 5 or rating label located in the boiler’s vestibule compartment. Adjust gas valve pressure regulator as necessary (turn adjustment screw counterclockwise to decrease manifold pressure, or clockwise to increase manifold pressure). If pressure cannot be attained, check gas valve inlet pressure. If less than minimum indicated in Table 5 or boiler’s rating label, contact gas supplier for assistance.
3. Clock gas meter for at least 30 seconds. Use Table 13 to determine gas flow rate in Cubic Feet per Hour.

WARNING

Failure to properly adjust gas input rate will result in over firing or under firing of the appliance. Improper and unsafe boiler operation may result.

4. Determine Input Rate. Multiply gas flow rate by gas heating value.
5. Compare measured input rate to input rate stated on rating plate.
 - a. Boiler must not be over fired. Reduce input rate by decreasing manifold pressure. Do not reduce more than 0.3 inch w.c. If boiler is still overfired, contact your U.S. Boiler distributor or Regional Office for replacement Gas Orifice.

- b. Increase input rate if less than 98% of rating plate input. Increase manifold gas pressure no more than 0.3 inch w.c. If measured input rate is still less than 98% of rated input:
 - i. Remove Main Burners per procedure in Section IX: Service.
 - ii. Remove gas orifices. Drill one (1) drill size larger (drill size is stamped on orifice, or see Section X: Repair Parts).
 - iii. Reinstall gas orifices and main burners. Measure input rate.
6. Recheck Main Burner Flame.
7. Return other gas-fired appliances to previous conditions of use.

Q. Review User’s Information Manual and system operation with owner or operator.

TABLE 13: GAS FLOW RATE IN CUBIC FEET PER HOUR

Seconds for One Revolution	Size of Gas Meter Dial		
	One-Half Cu. Ft.	One Cu. Ft.	Two Cu. Ft.
30	60	120	240
32	56	113	225
34	53	106	212
36	50	100	200
38	47	95	189
40	45	90	180
42	43	86	172
44	41	82	164
46	39	78	157
48	37	75	150
50	36	72	144
52	35	69	138
54	33	67	133
56	32	64	129
58	31	62	124
60	30	60	120

IX. Service

DANGER

This boiler uses flammable gas, high voltage electricity, moving parts, and very hot water under high pressure. Assure that all gas and electric power supplies are off and that the water temperature is cool before attempting any disassembly or service.

Assure that all gas valves and electrical disconnect switches are off before attempting any disassembly or service.

Do not attempt any service work if gas is present in the air in the vicinity of the boiler. Never modify, remove or tamper with any control device.

WARNING

This boiler must only be serviced and repaired by skilled and experienced service technicians.

If any controls are replaced, they must be replaced with identical models.

Read, understand and follow all the instructions and warnings contained in all the sections of this manual.

If any electrical wires are disconnected during service, clearly label the wires and assure that the wires are reconnected properly.

Never jump out or bypass any safety or operating control or component of this boiler.

Read, understand and follow all the instructions and warnings contained in ALL of the component instruction manuals.

Assure that all safety and operating controls and components are operating properly before placing the boiler back in service.

A. General. Inspection and service should be conducted annually. Turn off electrical power and gas supply while conducting service or maintenance. Follow instructions TO TURN OFF GAS TO APPLIANCE. See Figure 36.

B. Low water cutoff (if so equipped).

Probe Type (Annual Service). Probe type LWCO should be removed once a year, examined and cleaned of any dirt accumulations to assure proper operations. Do not attempt to repair mechanisms in the field. Complete replacement mechanisms, including necessary gaskets and installation instructions, are available from the manufacturer.

C. Vent/Air Intake System. Inspect for obstructions, soot accumulation, proper support, and deterioration of pipe, fittings, and joints.

1. Clean terminal screens. Terminals must be free of obstruction, undamaged, with screens securely in place.
2. Terminal and wall thimbles (if used) must be weathertight.
3. Pipe must be full round shape, and show no damage from impact or excessive temperature.

4. Pipe must be supported at minimum five (5) foot intervals and must not sag.
5. All vent joints must be secure and watertight.
6. All air intake joints must be secure and airtight. Horizontal vent tee drain or vertical vent tee drain (if used) must have minimum 6 inch trap and allow condensate to flow freely. To Clean:
 - a. Disconnect drain tube from drain fitting.
 - b. Flush drain tube with water. Fill trap with water.
 - c. Securely fasten drain tube to drain fitting, providing gas-tight and watertight seal.
7. If pipe must be disassembled for removal of obstructions or resealing of joint, see Section III, Paragraph C.

D. Boiler Flue Passages. Inspect for blockage or soot accumulation.

1. Remove Main Burners. See Figure 44.
 - a. Remove front door.
 - b. Remove air intake box front door.
 - i. Remove sheet metal screws.
 - c. Disconnect pilot tubing and pilot lead wires at the gas valve.

- d. Remove wires to Flame Roll-out Switch.
 - e. Remove air diffuser screen.
 - f. Remove Burner Access Panel.
 - g. Mark location of Main Burner with Pilot Bracket on gas manifold.
 - h. Hold Main Burner on throat. Lift front of burners to clear orifice. Burner which holds pilot can be removed by lifting the burner adjacent to its right first.
2. Disconnect Vent Connector and Vent Pipe from Blower Outlet
 3. Remove Jacket Top Panel.
 4. Disconnect the Black and Gary Silicone Tubing from the Canopy.
 5. Disconnect Wiring Harness from Blower Motor.
 6. Remove Canopy/Blower Assembly.
 - a. Loosen the (4) screws from Canopy.
 7. Remove Flue Gas Baffles. Inspect Flue Gas Baffles for deterioration.
 8. Inspect flue passages. Clean with flue brush. See Figure 44.
 9. Inspect heating surface in combustion chamber. Clean with straight handle wire brush.
 10. Install Flue Gas Baffles.
 11. Replace Canopy/Blower Assembly.
 12. Connect Silicone Tubing between Pressure Fittings on Canopy Assembly and Pressure Switch. Route through bushings in Vestibule Panel . See Figure 42.

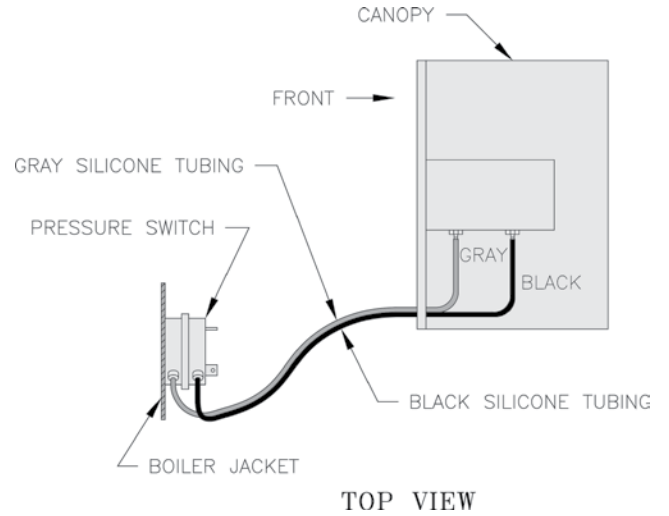

Figure 42: Silicone Tubing Assembly

13. Install Jacket Top Rear Panel.
14. Connect Vent System. See Figure 43.
15. Connect Blower Motor Wiring Harness.

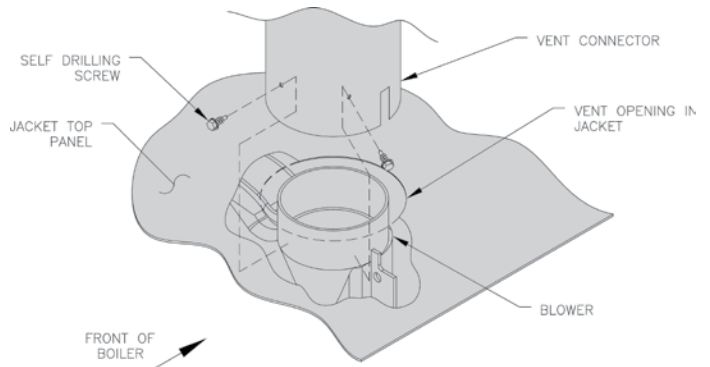

Figure 43: Blower Vent Connector Assembly

TABLE 14: PILOT BURNER LOCATION

Boiler Model	Main Burner with Pilot Bracket	Pilot Burner Located Between Main Burners *
SCG-3	2	2 & 3
SCG-4	3	3 & 4
SCG-5	4	4 & 5
SCG-6	5	5 & 6
SCG-7	6	6 & 7
SCG-8	7	7 & 8
SCG-9	8	8 & 9

* Main burners numbered left to right as viewed from front of boiler.

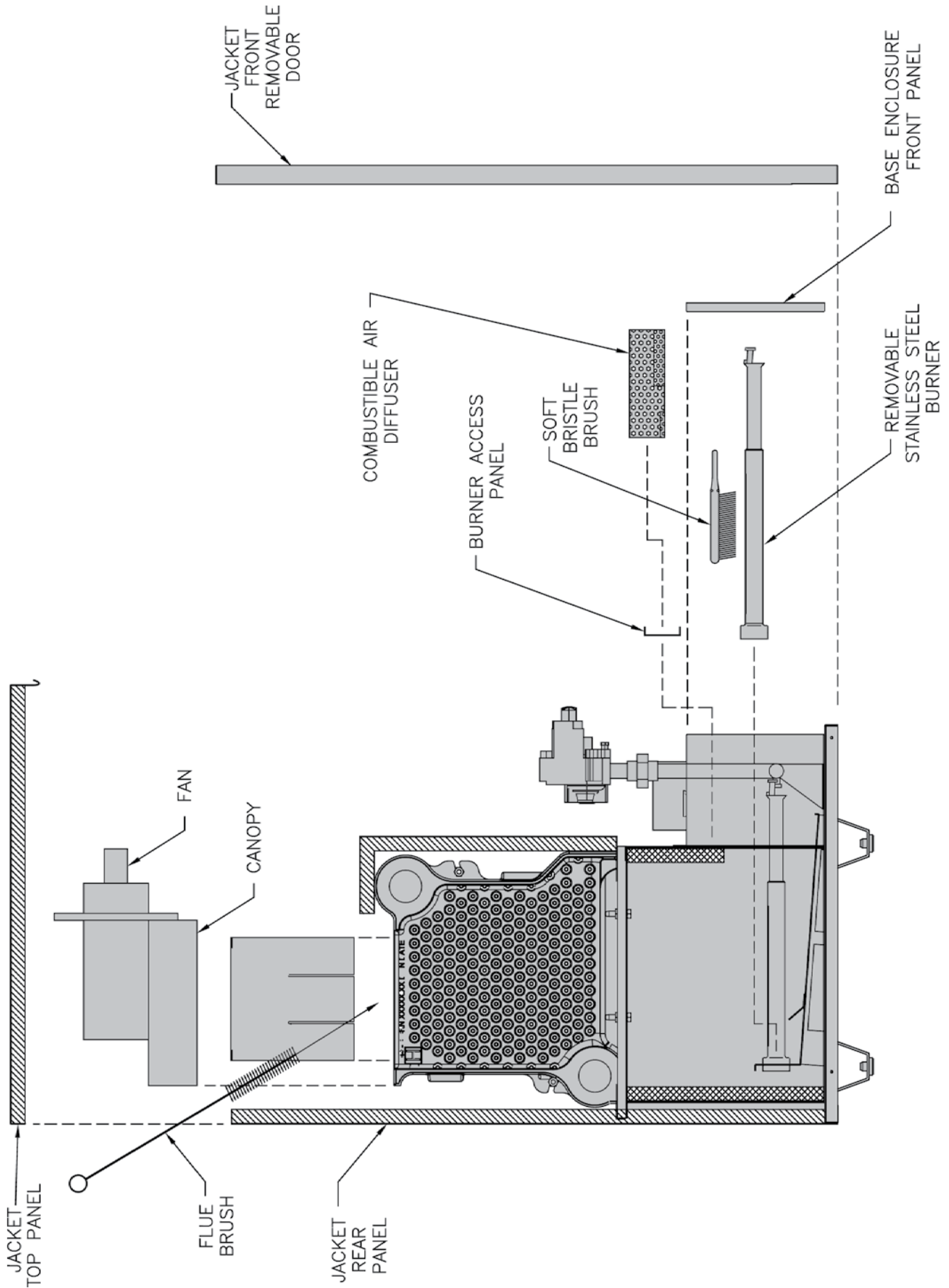

Figure 44: Flue and Burner Cleanout, 1" Burner

E. Main Burners and Firebox.

1. Vacuum firebox. Exercise care - do not damage base insulation.
2. Clean main burners. Brush top of burners with soft bristle brush. See Figure 44. Vacuum to remove any dirt and lint.
3. Vacuum tip of pilot burner.
4. Check gas orifices for lint and dirt. Clean as necessary.
5. Install main burners by reversing procedure to remove burners.
 - a. Pilot burner must be installed in original location. See Table 14.
 - b. Main burners must be properly secured in burner tray slot at rear of firebox and over gas orifice. See Figure 44.
 - c. Pilot gas supply and pilot lead wires must be reconnected.
 - d. Burner access panel must be securely in place.
 - e. Reinstall air diffuser screen.
 - f. Reconnect Flame Roll-out wires.
 - g. Air Intake Box Front Door must be installed.

F. Check operation. Follow steps G through P from Section VIII: System Start-up.

G. Procedure for Measuring Differential Pressure (See Figure 45).

1. With boiler off, remove Gray and Black Hoses at differential pressure switch.
2. With tees and ¼ inch aluminum stubs, connect water manometer as shown with additional tubing.
3. Start boiler and read Pressure on Manometer when boiler water temperature reaches operating temperature. Refer to Table 15 for minimum readings.

NOTE: If switch drops-out before boiler reaches temperature or if pressure differential readings are below minimums shown in Table 15, check for cracks in hose or contact your nearest U.S. Boiler representative.

4. Stop boiler, remove manometer and reconnect hoses to differential pressure switch. See Figures 42 and 45.

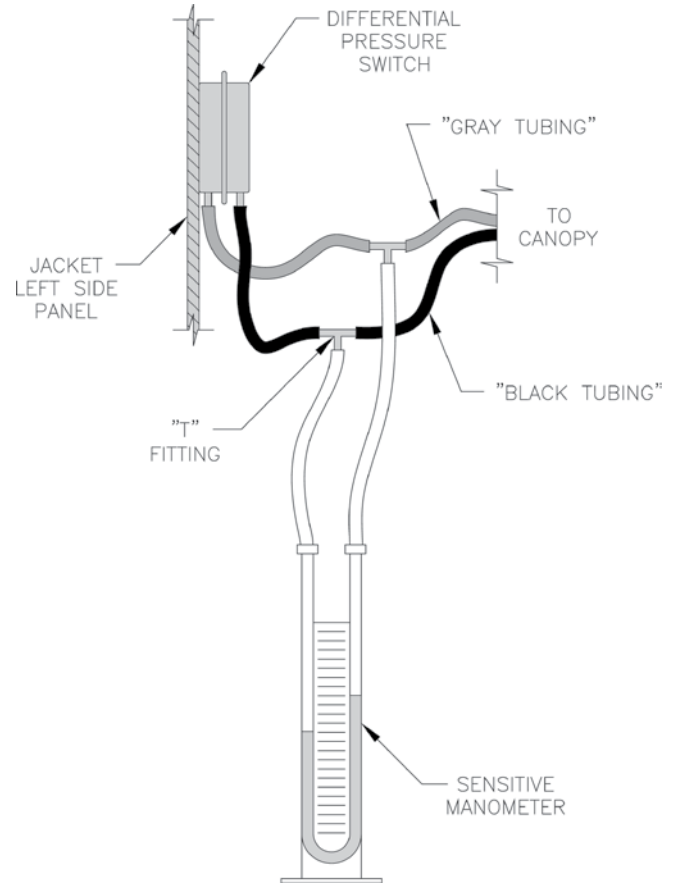
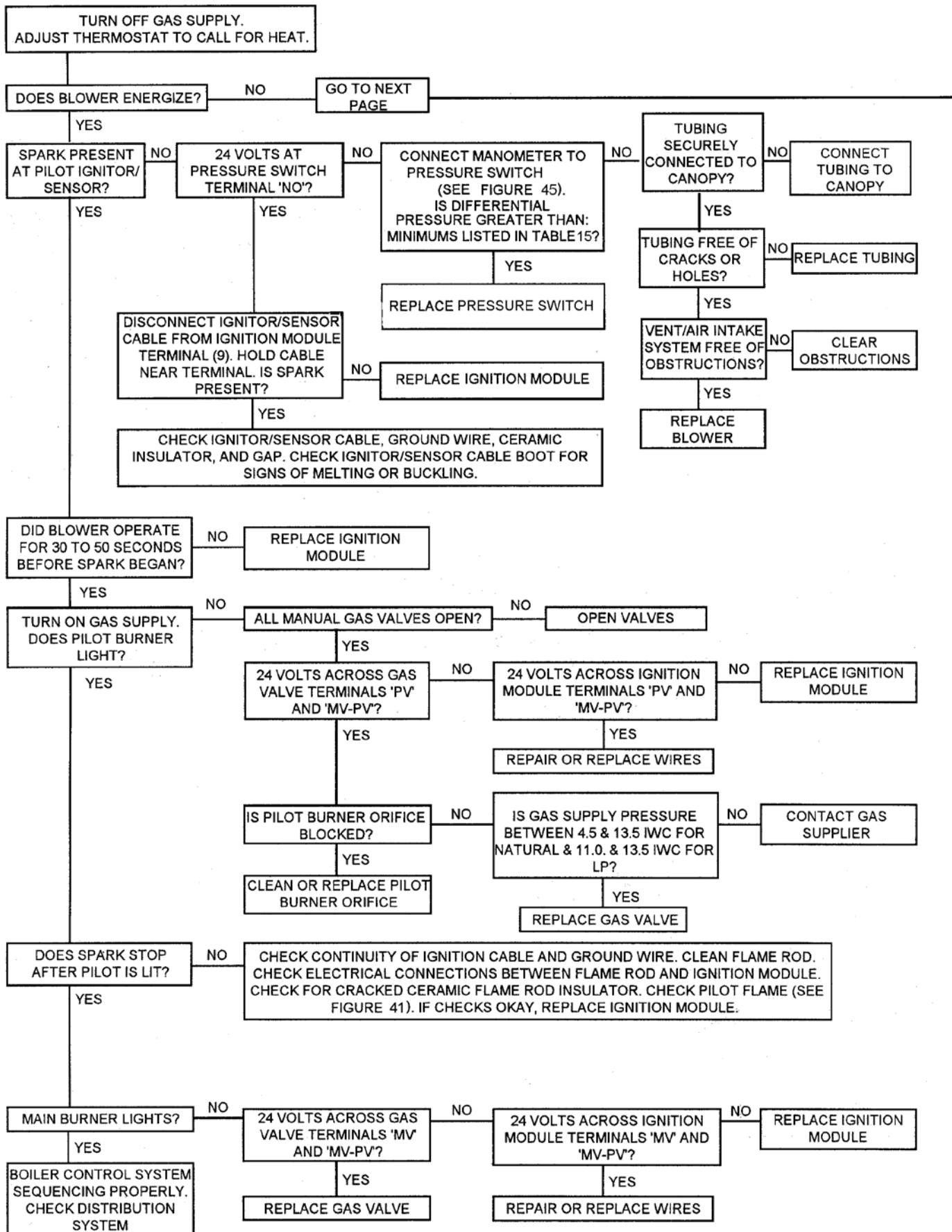
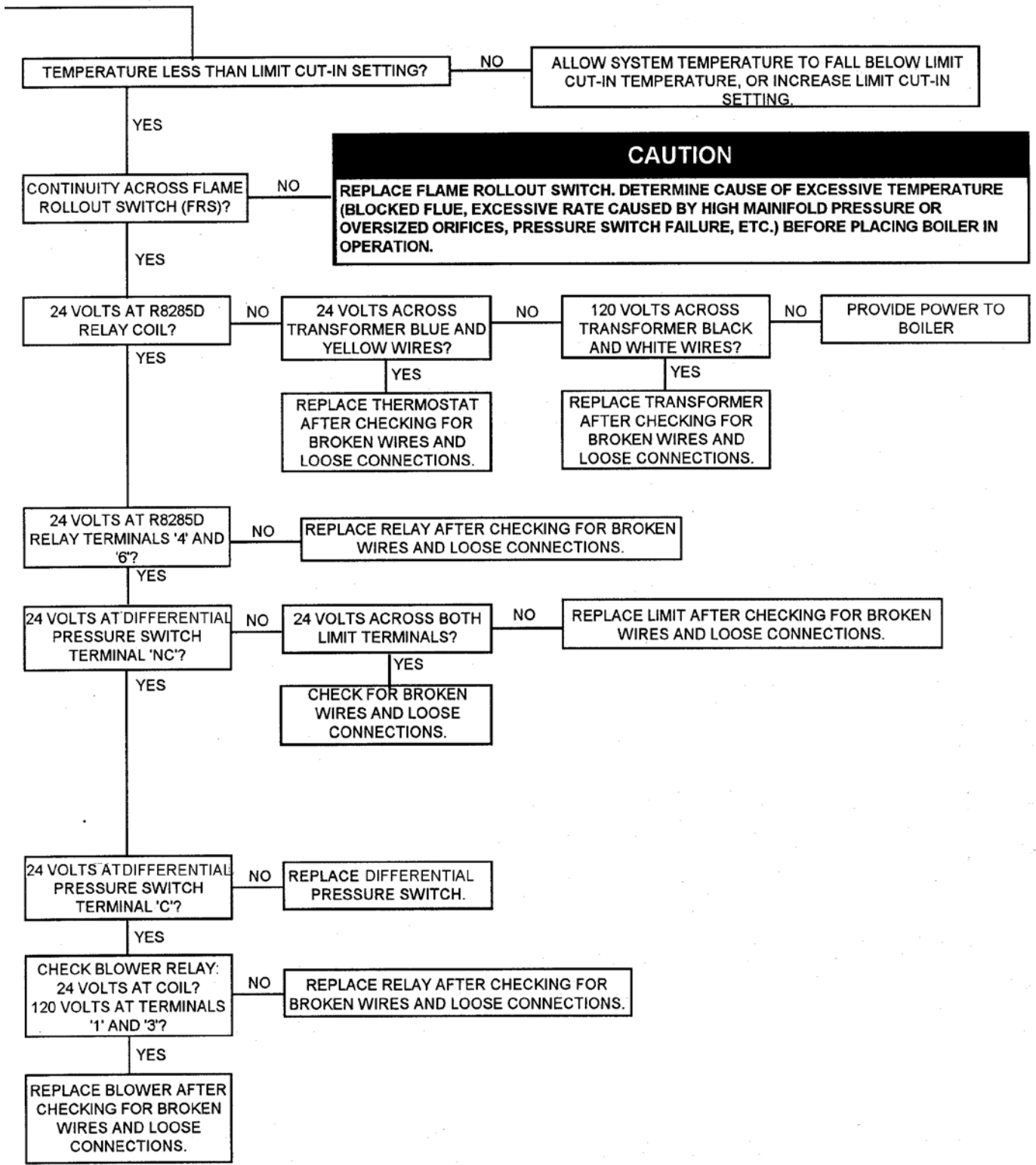

Figure 45: Differential Pressure Measurement

TABLE 15: DIFFERENTIAL PRESSURE SWITCH SETTINGS

Boiler Model	Minimum Differential Pressure	
	Sea Level to 4,999 Ft.	5,000 - 10,000 Ft. Elevation
SCG-3	1.32" w.c.	.80" w.c.
SCG-4	1.17" w.c.	.65" w.c.
SCG-5	1.17" w.c.	.65" w.c.
SCG-6	.88" w.c.	.35" w.c.
SCG-7	.80" w.c.	.30" w.c.
SCG-8	.88" w.c.	.35" w.c.
SCG-9	.88" w.c.	.35" w.c.





Key No.	Description	[Quantity] Part Number						
		SCG-3	SCG-4	SCG-5	SCG-6	SCG-7	SCG-8	SCG-9
1. CASTING ASSEMBLY								
1	Section Assembly	61707031	61707041	61707051	61707061	61707071	61707081	61707091
1A	Left End Section	71707001						
1B	Center Section	(1) 71707003	(2) 71707003	(3) 71707003	(4) 71707003	(5) 71707003	(6) 71707003	(7) 71707003
1C	Right End Section	71707002						
1D	Slip Nipple, #3	(4) 806600009	(6) 806600009	(8) 806600009	(10) 806600009	(12) 806600009	(14) 806600009	(16) 806600009
1E	Flue Gas Baffle	(2) 71107002	(3) 71107002	(4) 71107002	(5) 71107002	(6) 71107002	(7) 71107002	(8) 71107002
1F	Tie Rod, 1/4" -20	(2) 100109-01	(2) 100108-05	(2) 100108-07	(2) 100108-13	(2) 100108-14	(2) 100108-15	(2) 100108-16
1G	Hex Nut, 1/4" -20	(4) 80860407						

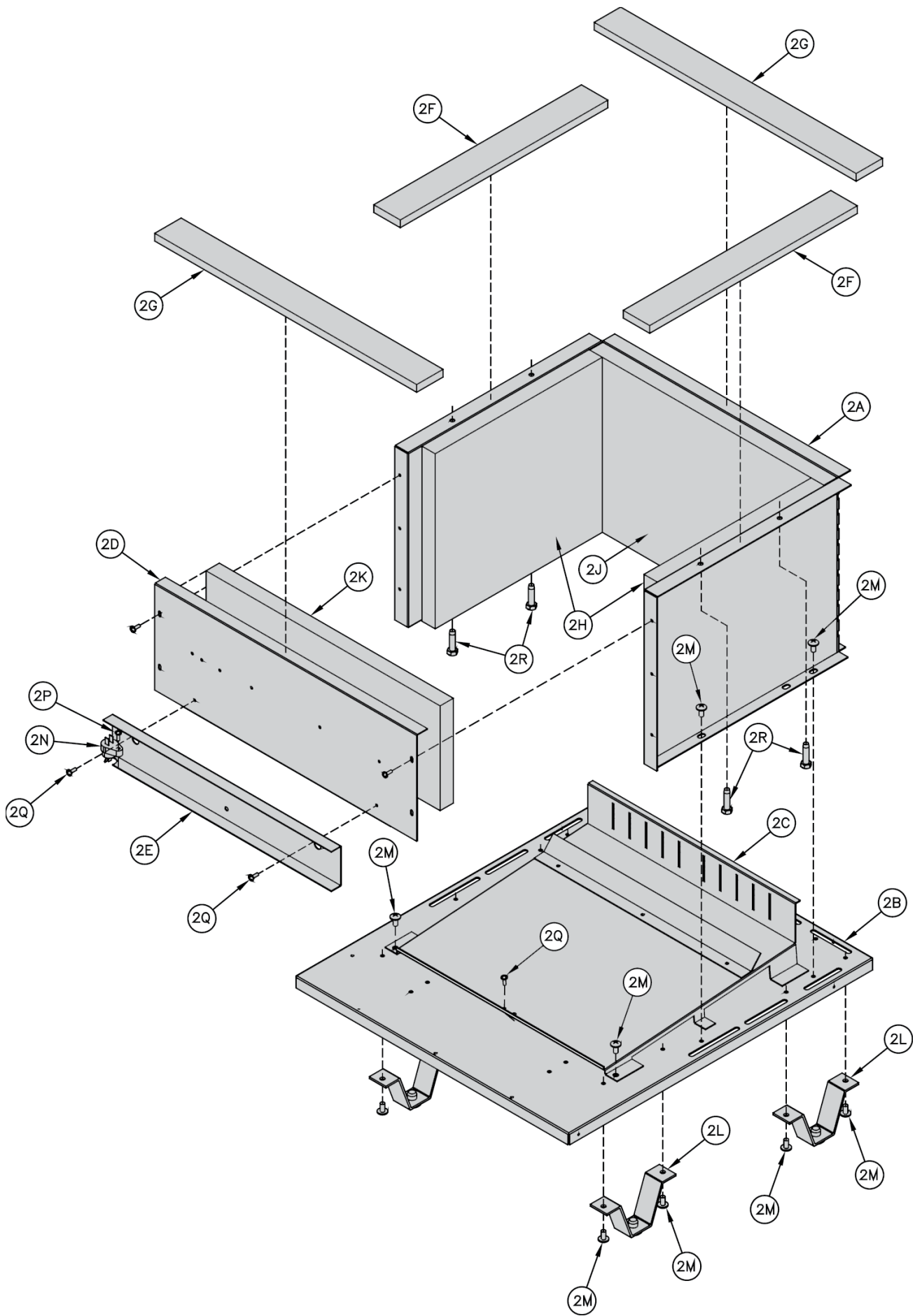

Key No.	Description	[Quantity] Part Number						
		SCG-3	SCG-4	SCG-5	SCG-6	SCG-7	SCG-8	SCG-9
2. BASE ASSEMBLY								
2A	Base Wrapper	71807031	71807041	71807051	71807061	71807071	71807081	71807091
2B	Base Tray	71807032	71807042	71807052	71807062	71807072	71807082	71807092
2C	Burner Tray Assembly	61807031	61807041	61807051	61807061	61807071	61807081	61807091
2D	Base Front Panel	71807035	71807045	71807055	71807065	71807075	71807085	71807095
2E	Burner Access Panel	102707-03	102707-04	102707-05	102707-06	102707-07	102707-08	102707-09
2F	Cerafelt Gasket 1/2" x 2"	9206003						
2G	Cerafelt Gasket 1/2" x 2"	9206003						
2H	Base Side Insulation	(2) 72007001						
2J	Base Rear Insulation	72007031	72007041	72007051	72007061	72007071	72007081	72007091
2K	Base Front Insulation	72007032	72007042	72007052	72007062	72007072	72007082	72007092
2L	Base Leg Assembly	(4) 6186001						
2M	Self Tapping Screw, 1/4" -20 x 1/2"	(18) 80860700						
2N	Flame Roll-out Switch	80160044						
2P	Sheet Metal Screw, #8 x 3/4"	80860030						
2Q	Self Tapping Screw, 10 -32 x 3/8"	(5) 80860705			(6) 80860705		(7) 80860705	
2R	Self Tapping Screw Hex Cap, 5/16 -18 x 1-1/4"	(4) 80860717						

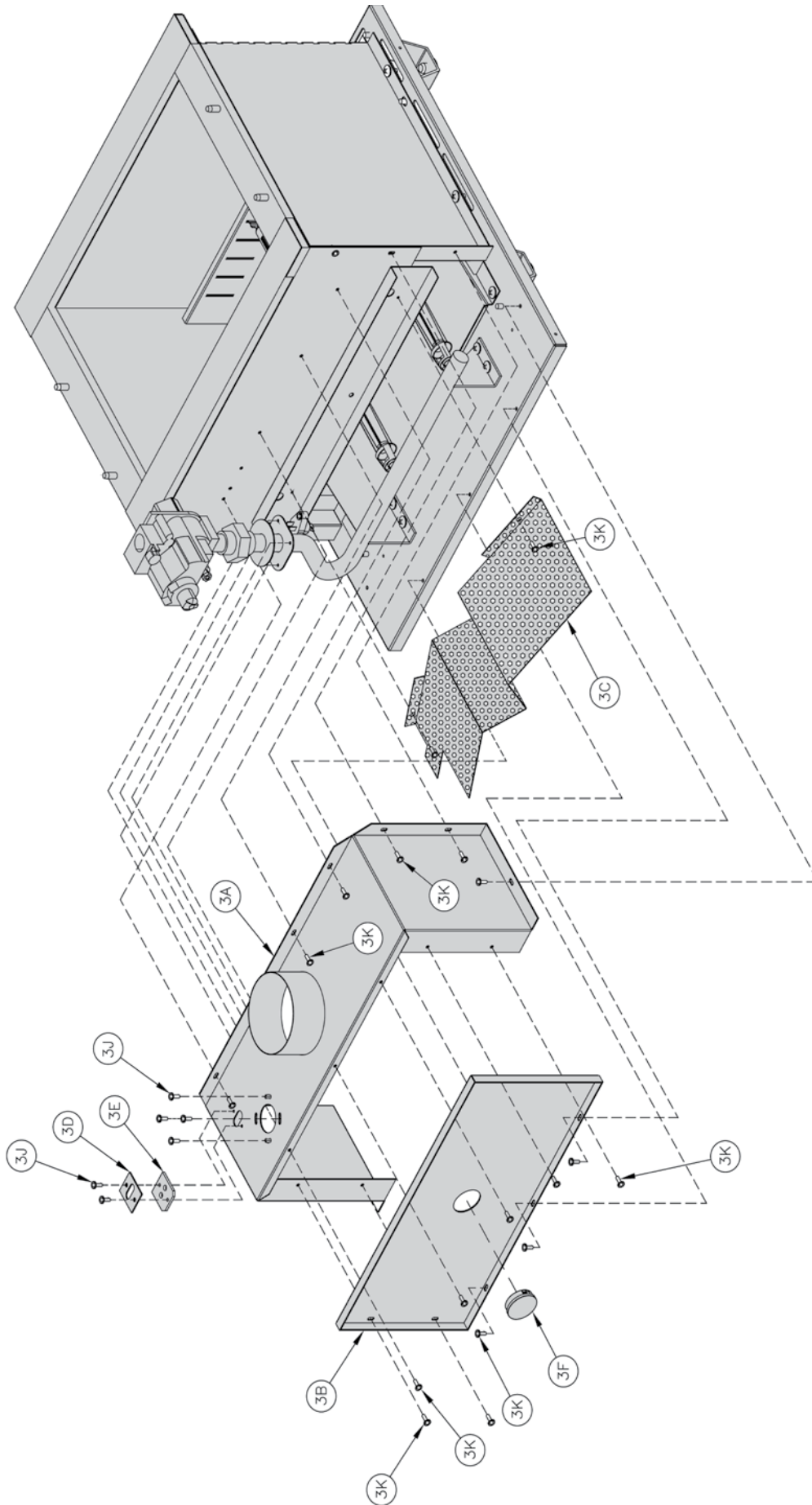

Key No.	Description	[Quantity] Part Number						
		SCG-3	SCG-4	SCG-5	SCG-6	SCG-7	SCG-8	SCG-9
2. BASE ENCLOSURE ASSEMBLY								
3A	Air Box Assembly	61807032	61807042	61807052	61807062	61807072	61807082	61807092
3B	Air Box Door	71807034	71807044	71807054	71807064	71807074	71807084	71807094
3C	Combustion Air Diffuser	N/A	71807049	71807059	71807069	71807079	71807089	71807099
3D	Pilot Tube Gasket Cover Plate	7096002						
3E	Pilot Tube Gasket	8206038						
3F	Window Plug	102202-01						
3J	Sheet Metal Screws #8 x 1/2"	(6) 80860000						
3K	Self Tapping Screw, 10-32 x 3/8"	(18) 80860705			(22) 80860705			

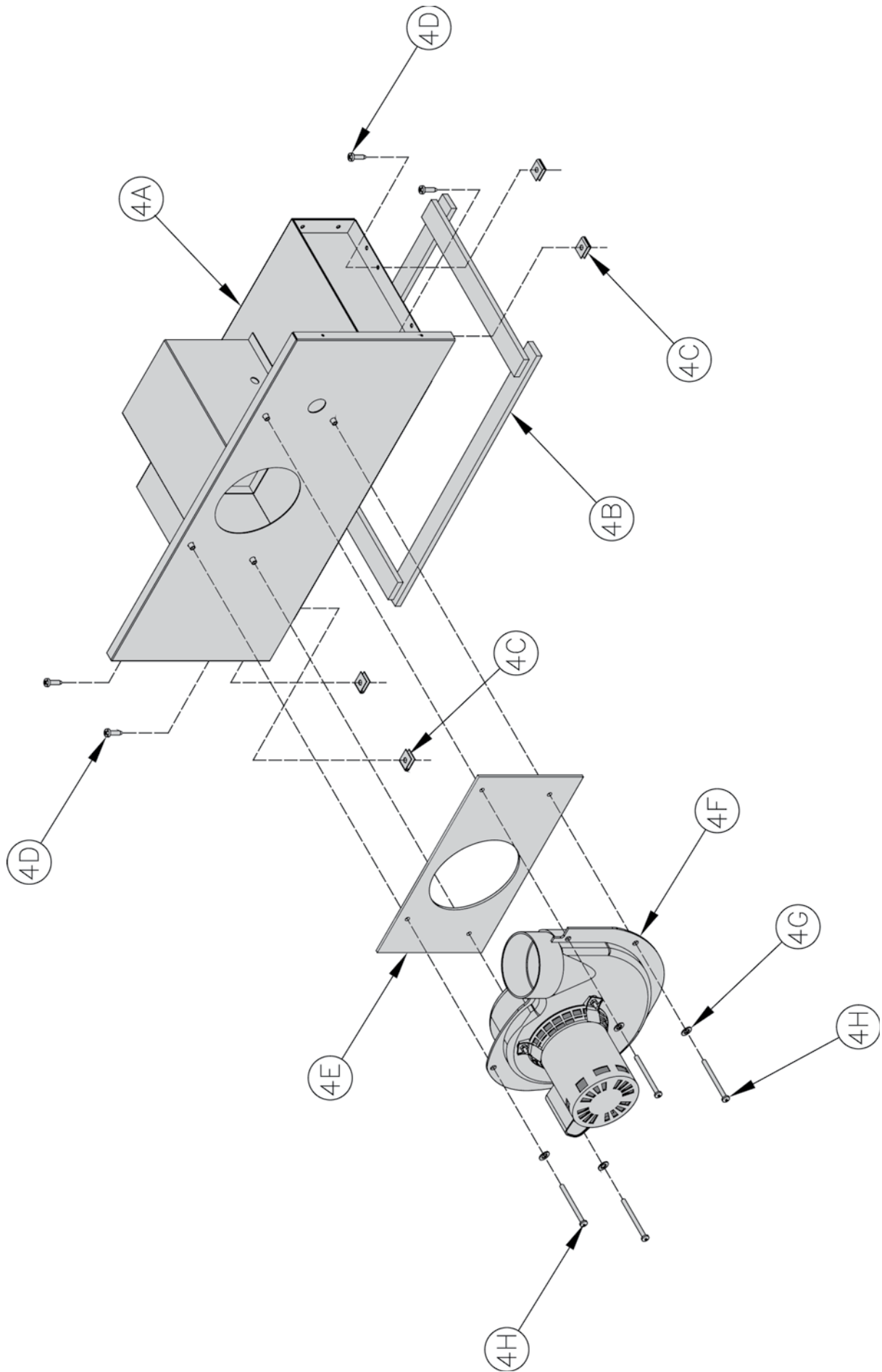

Key No.	Description	[Quantity] Part Number						
		SCG-3	SCG-4	SCG-5	SCG-6	SCG-7	SCG-8	SCG-9
4. FAN/CANOPY ASSEMBLY								
4A	Canopy Assembly - Sea Level	61107031	61107041	61107051	61107061	61107071	61107081	61107091
	Canopy Assembly - High Altitude	61107032	61107042	61107052	61107062	61107072	61107082	61107092
4B	Cerafelt	9206005						
4C	U-Clip	(4) 80861512						
4D	Sheet Metal Screw, #10 x 1"	(4) 808600141						
4E	Fan Gasket	8206085						
4F	Fan	81161512						
4G	Lock Washer, #10	(4) 80860636						
4H	Machine Screw, #10-24 x 2½"	(4) 808608982						

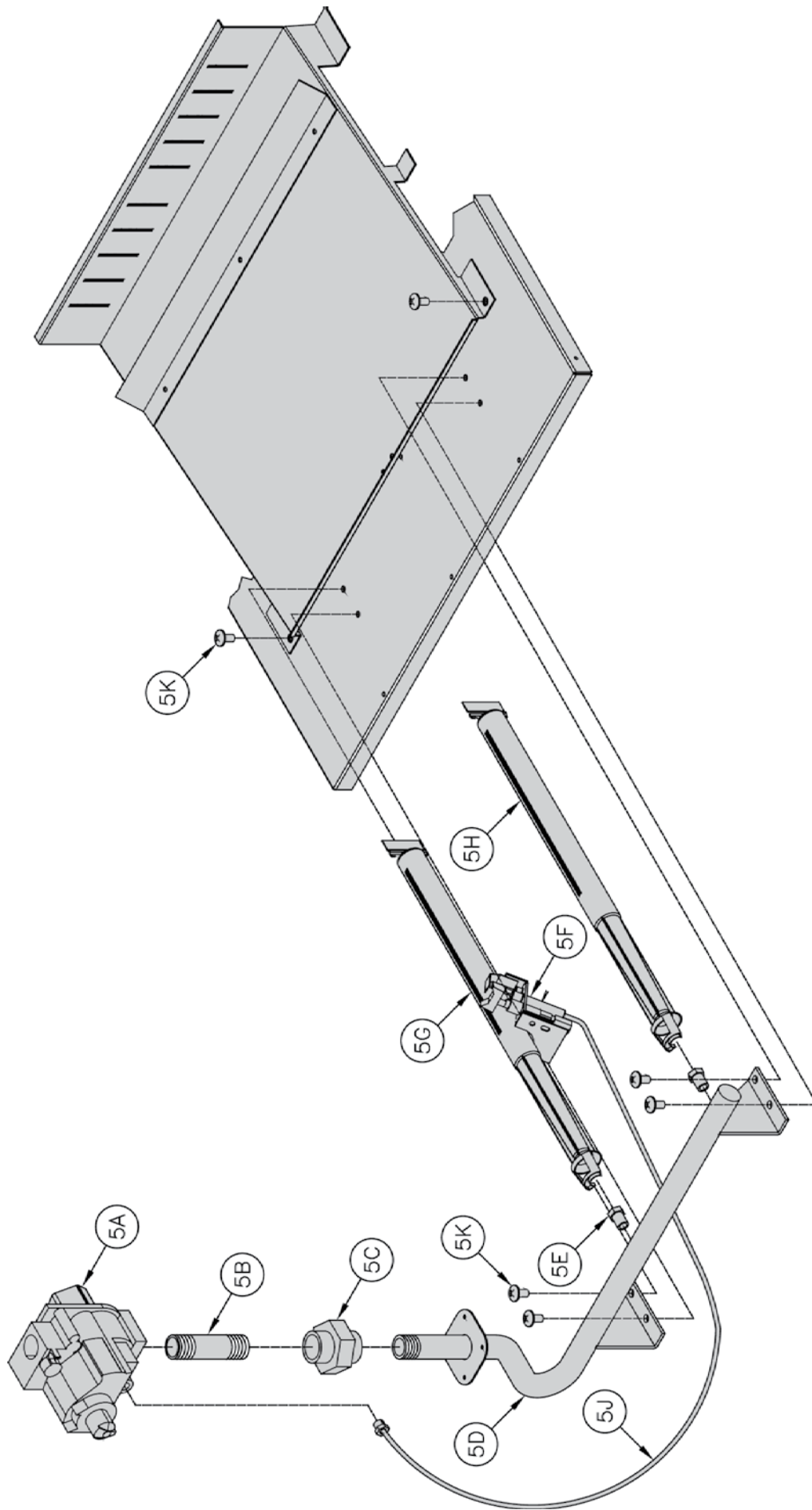

Key No.	Description	[Quantity] Part Number						
		SCG-3	SCG-4	SCG-5	SCG-6	SCG-7	SCG-8	SCG-9
5. BURNER ASSEMBLIES								
5A	Gas Valve (Natural Gas), Honeywell VR8204P1171	81660282				N/A		
	Gas Valve (Natural Gas), Honeywell VR8304P4496	N/A				81660283		
	Gas Valve (LP Gas), Honeywell VR8204C3015	81660146				N/A		
	Gas Valve (LP Gas), Honeywell VR8304P4280	N/A				81660160		
5B	Nipple, ½" NPT x Close	806600040				N/A		
	Nipple, ¾" NPT x Close	N/A				806600022		
5C	Union, ½" NPT	806604023				N/A		
	Union, ¾" NPT	N/A				806604001		
5D	½" Gas Manifold	82207031	82207041	82207051	82207061	---	---	---
	¾" Gas Manifold	---	---	---	---	82207071	82207081	82207191
5E	Burner Orifices - Natural Gas #47	(4) 822710	(6) 822710	(8) 822710	(10) 822710	(12) 822710	(14) 822710	(16) 822710
	Burner Orifices - LP Gas 1.20 mm	(4) 822792	(6) 822792	(8) 822792	(10) 822792	(12) 822792	(14) 822792	(16) 822792
5F	Pilot Assembly - Natural Gas	8236163						
	Pilot Assembly - LP Gas	8236164						
5G	Pilot Burner	100147-01						
5H	Main Burner	(3) 100146-01	(5) 100146-01	(7) 100146-01	(9) 100146-01	(11) 100146-01	(13) 100146-01	(15) 100146-01
5J	Pilot Tubing	8236122						
5K	Self Tapping Screw, ¼ - 20 x ½"	(6) 80860700						

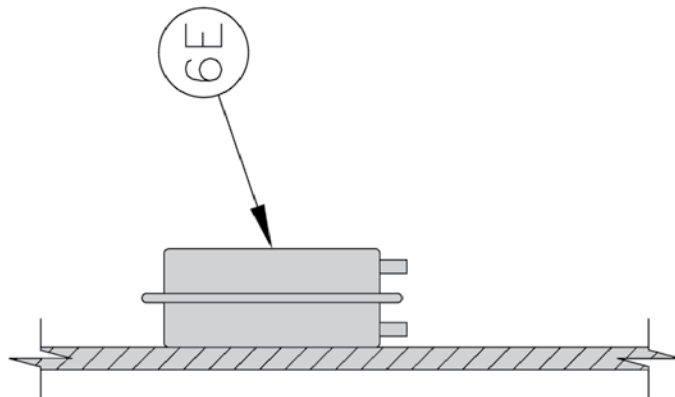
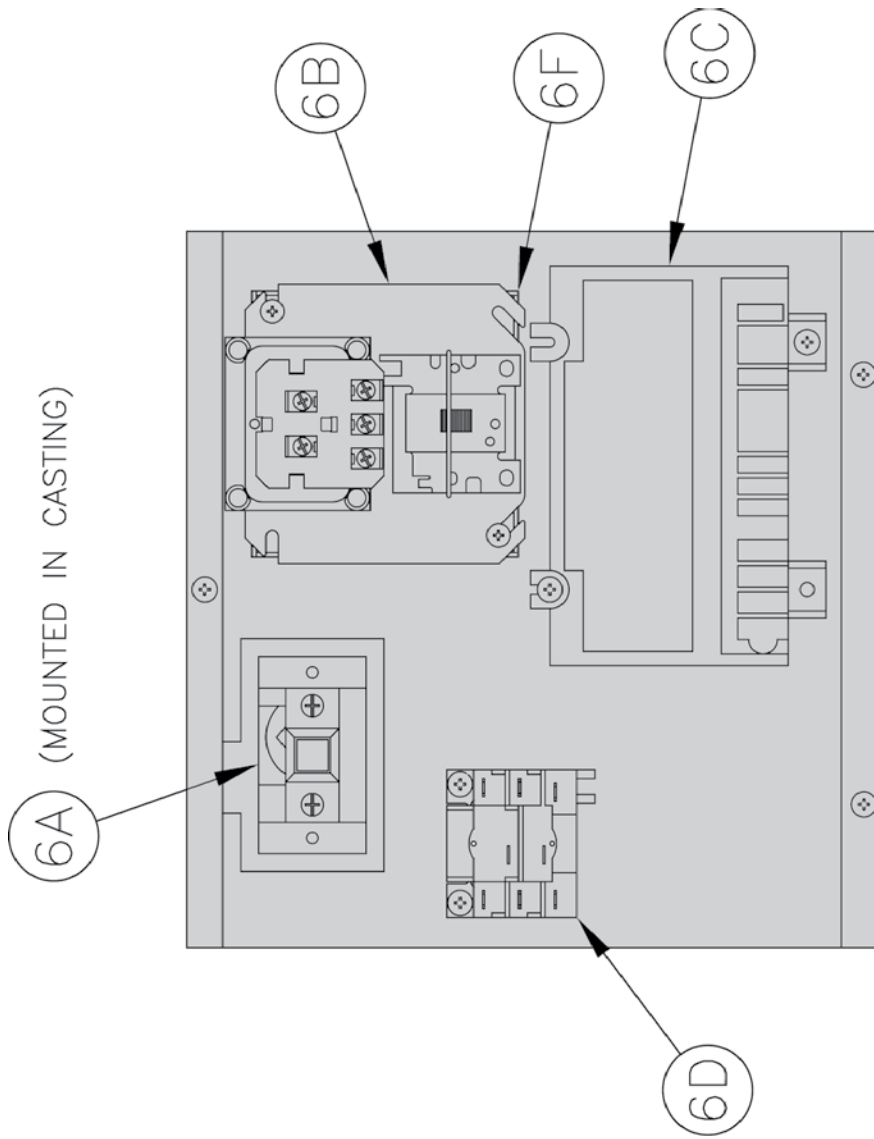

JACKET LEFT
SIDE PANEL

Key No.	Description	[Quantity] Part Number						
		SCG-3	SCG-4	SCG-5	SCG-6	SCG-7	SCG-8	SCG-9
6. CONTROL PANEL ASSEMBLY								
6A	Limit, Honeywell L4080D	100189-01						
6B	Transformer/Relay, Honeywell R8285D	80160155U						
6C	Ignition Module, Honeywell S8670E3003	100959-01						
6D	Blower Relay, Honeywell R8222U1006	80160096U						
6E	Differential Pressure Switch Sea Level 0' - 4999'	80160762	80160761	80160760	80160759	80160760		
	High Altitude - 5000' - 10,000'	80160759	80160763	80160764	80160765	80160764		
6F	Junction Box	8136259						

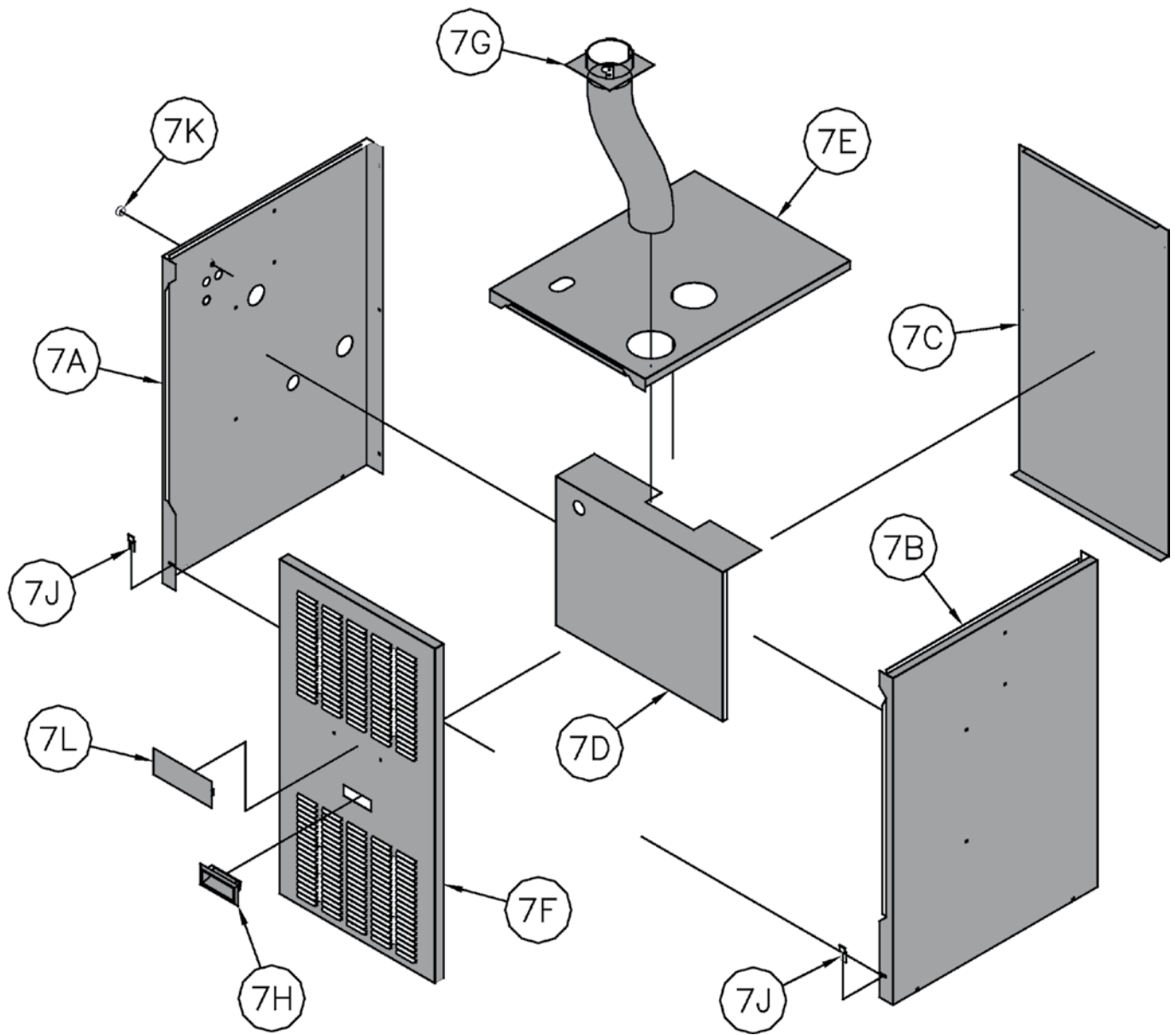

Key No.	Description	[Quantity] Part Number						
		SCG-3	SCG-4	SCG-5	SCG-6	SCG-7	SCG-8	SCG-9
7. JACKET PARTS								
7A	Jacket Left Side Panel	60407002						
7B	Jacket Right Side Panel	60407001						
7C	Rear Panel	60407033	60407043	60407053	60407063	60407073	60407083	60407093
7D	Vestibule Panel	60407034	60407044	60407054	60407064	60407074	60407084	60407094
7E	Top Panel	60407032	60407042	60407052	60407062	60407072	60407082	60407092
7F	Front Door	101354-03	101354-04	101354-05	101354-06	101354-07	101354-08	101354-09
7G	Air Intake Collar Assembly	60407003		60407004		60407005		
7H	Handle	8056184						
7J	Door Clip	(2) 7041921						
7K	Bushing	8136048						
7L	Burnham Hydronics Logo	81460099						

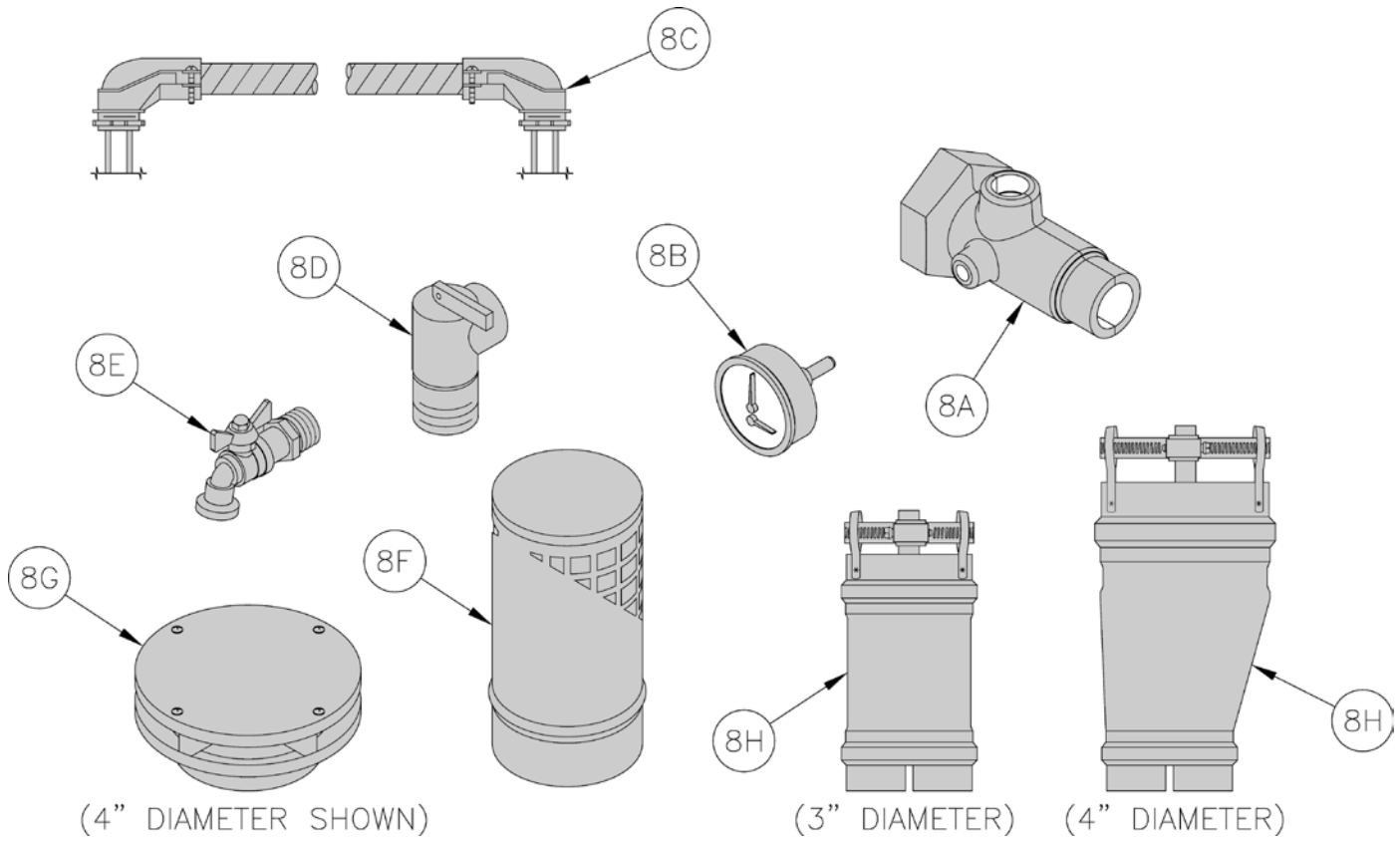

Key No.	Description	[Quantity] Part Number						
		SCG-3	SCG-4	SCG-5	SCG-6	SCG-7	SCG-8	SCG-9
8. MISCELLANEOUS PARTS CARTON								
8A	Water Manifold							80607001
8B	Temperature/Pressure Gauge							100282-01
8C	Circulator Wiring Harness							6130701
8D	Safety Relief Valve							81660363
8E	Boiler Drain Valve							806603061
8F	Vent Terminal			8110701			8110702	
8G	Air Intake Terminal	6116045		6116044		6116063		
8H	Vent Connector			8110703			8110704	

Important Product Safety Information **Refractory Ceramic Fiber Product**

Warning:

The Repair Parts list designates parts that contain refractory ceramic fibers (RCF). RCF has been classified as a possible human carcinogen. When exposed to temperatures about 1805°F, such as during direct flame contact, RCF changes into crystalline silica, a known carcinogen. When disturbed as a result of servicing or repair, these substances become airborne and, if inhaled, may be hazardous to your health.

AVOID Breathing Fiber Particulates and Dust

Precautionary Measures:

Do not remove or replace RCF parts or attempt any service or repair work involving RCF without wearing the following protective gear:

1. A National Institute for Occupational Safety and Health (NIOSH) approved respirator
 2. Long sleeved, loose fitting clothing
 3. Gloves
 4. Eye Protection
- Take steps to assure adequate ventilation.
 - Wash all exposed body areas gently with soap and water after contact.
 - Wash work clothes separately from other laundry and rinse washing machine after use to avoid contaminating other clothes.
 - Discard used RCF components by sealing in an airtight plastic bag. RCF and crystalline silica are not classified as hazardous wastes in the United States and Canada.

First Aid Procedures:

- If contact with eyes: Flush with water for at least 15 minutes. Seek immediate medical attention if irritation persists.
- If contact with skin: Wash affected area gently with soap and water. Seek immediate medical attention if irritation persists.
- If breathing difficulty develops: Leave the area and move to a location with clean fresh air. Seek immediate medical attention if breathing difficulties persist.
- Ingestion: Do not induce vomiting. Drink plenty of water. Seek immediate medical attention.

Limited Warranty

For Residential Grade Water and Steam Boilers

Using Cast Iron, Carbon Steel, Cast Aluminum,
or Stainless Steel Heat Exchangers
and Parts/Accessories

Subject to the terms and conditions set forth below, U.S. Boiler Company, Inc. Lancaster, Pennsylvania hereby extends the following limited warranties to the original owner of a residential grade water or steam boiler or U.S. Boiler Company, Inc. supplied parts and/or accessories manufactured and shipped on or after July 1, 2008:

ONE YEAR LIMITED WARRANTY ON RESIDENTIAL GRADE BOILERS AND PARTS / ACCESSORIES SUPPLIED BY U.S. BOILER COMPANY, INC.

U.S. Boiler Company, Inc. warrants to the original owner that its residential grade water and steam boilers and parts/accessories comply at the time of manufacture with recognized hydronic industry standards and requirements then in effect and will be free of defects in material and workmanship under normal usage for a period of one year from the date of original installation. If any part of a residential grade boiler or any part or accessory provided by U.S. Boiler Company, Inc. is found to be defective in material or workmanship during this one year period, U.S. Boiler Company, Inc. will, at its option, repair or replace the defective part.

HEAT EXCHANGER WARRANTIES

U.S. Boiler Company, Inc. warrants to the original owner that the heat exchanger of its residential grade boilers will remain free from defects in material and workmanship under normal usage for time period specified in the chart below of the original owner at the original place of installation. If a claim is made under this warranty during the "No Charge" period from the date of original installation, U.S. Boiler Company, Inc. will, at its option, repair or replace the heat exchanger. If a claim is made under this warranty after the expiration of the "No Charge" period from the date of original installation, U.S. Boiler Company, Inc. will, at its option and upon payment of the pro-rated service charge set forth below, repair or replace the heat exchanger. The service charge applicable to a heat exchanger warranty claim is based upon the number of years the heat exchanger has been in service and will be determined as a percentage of the retail price of the heat exchanger model involved at the time the warranty claim is made as follows:

Years in Service	Service Charge as a % of Retail Price																																																																					
	1-5	6	7	8	9	10	11	12	13	14	15	16	17	18	19	20	21	22	23	24	25	26	27	28	29	30	31	32	33	34	35	36	37	38	39	40	41	42	43	44	45	46	47	48	49	50	51	52	53	54	55	56	57	58	59	60	61	62	63	64	65	66	67	68	69	70	71	72	73	74
Cast Iron Water	No Charge					5	10	15	20	25	30	35	40	45	50	55	60	65	70	75																																																		
Cast Iron Steam*	No Charge					100																																																																
Carbon Steel	No Charge					5	10	15	20	25	30	35	40	45	50	55	60	65	70	75																																																		
Cast Aluminum	No Charge					30	40	50	60	70	100																																																											
Stainless Steel	No Charge					30	40	50	60	70	100																																																											

NOTE: If the heat exchanger involved is no longer available due to product obsolescence or redesign, the value used to establish the retail price will be the published price as shown in the Burnham® Products Repair Parts Pricing where the heat exchanger last appeared or the current retail price of the then nearest equivalent heat exchanger.

***Burnham® MegaSteam™ Waterside Corrosion Warranty:** U.S. Boiler Company, Inc. warrants the cast iron sections of the Burnham® MegaSteam™ boiler to resist Temperature Induced Chloride Activated Graphitic Corrosion for a period of five years from the date of original installation. In the event that any cast iron section of a Burnham® MegaSteam™ boiler fails due to this corrosion mechanism during this period, U.S. Boiler Company, Inc. will repair or replace, at its option, the cast iron section assembly.

LIFETIME NIPPLE LEAKAGE WARRANTY

U.S. Boiler Company, Inc. warrants the cast iron and steel nipples that join the cast iron boiler sections to be free of defects in material and workmanship for the lifetime of the original owner at the original place of installation. In the event that such nipples are found to be defective in material and workmanship during this period, U.S. Boiler Company, Inc. will repair or replace at its option, the cast iron section assembly.

ADDITIONAL TERMS AND CONDITIONS

1. **Applicability:** The limited warranties set forth above are extended only to the original owner at the original place of installation within the United States and Canada. These warranties are applicable only to boilers, parts, or accessories designated as residential grade by U.S. Boiler Company, Inc. and installed in a single or two-family residence and do not apply to commercial grade products.
2. **Components Manufactured by Others:** Upon expiration of the one year limited warranty on residential grade boilers, all boiler components manufactured by others but furnished by U.S. Boiler Company, Inc. (such as oil burner, circulator and controls) will be subject only to the manufacturer's warranty, if any.
3. **Proper Installation:** The warranties extended by U.S. Boiler Company, Inc. are conditioned upon the installation of the residential grade boiler, parts, and accessories in strict compliance with U.S. Boiler Company, Inc. installation instructions. U.S. Boiler Company, Inc. specifically disclaims liability of any kind caused by or relating to improper installation.
4. **Proper Use and Maintenance:** The warranties extended by U.S. Boiler Company, Inc. conditioned upon the use of the residential grade boiler, parts, and accessories for its intended purposes and its maintenance accordance with U.S. Boiler Company, Inc. recommendations and hydronics industry standards. For proper installation, use, and maintenance, see all applicable sections of the Installation and Operating, and Service Instructions Manual furnished with the unit.
5. This warranty does not cover the following:
 - a. Expenses for removal or reinstallation. The homeowner will be responsible for the cost of removing and reinstalling the alleged defective part or its replacement and all labor and material connected therewith, and transportation to and from U.S. Boiler Company, Inc.
 - b. Components that are part of the heating system but were not furnished by U.S. Boiler Company, Inc. as part of the residential boiler.
 - c. Improper burner adjustment, control settings, care or maintenance.

- d. This warranty cannot be considered as a guarantee of workmanship of an installer connected with the installation of the U.S. Boiler Company, Inc. boiler, or as imposing on U.S. Boiler Company, Inc. liability of any nature for unsatisfactory performance as a result of faulty workmanship in the installation, which liability is expressly disclaimed.
 - e. Boilers, parts, or accessories installed outside the 48 contiguous United States, the State of Alaska and Canada.
 - f. Damage to the boiler and/or property due to installation or operation of the boiler that is not in accordance with the boiler installation and operating instruction manual.
 - g. Any damage or failure of the boiler resulting from hard water or scale buildup in the heat exchanger.
 - h. Any damage caused by improper fuels, fuel additives or contaminated combustion air that may cause fireside corrosion and/or clogging of the burner or heat exchanger.
 - i. Any damage resulting from combustion air contaminated with particulate which cause clogging of the burner or combustion chamber including but not limited to sheetrock or plasterboard particles, dirt, and dust particulate.
 - j. Any damage, defects or malfunctions resulting from improper operation, maintenance, misuse, abuse, accident, negligence including but not limited to operation with insufficient water flow, improper water level, improper water chemistry, or damage from freezing.
 - k. Any damage caused by water side clogging due to dirty systems or corrosion products from the system.
 - l. Any damage resulting from natural disaster.
 - m. Damage or malfunction due to the lack of required maintenance outlined in the Installation and Operating Manual furnished with the unit.
6. **Exclusive Remedy:** U.S. Boiler Company, Inc. obligation for any breach of these warranties is limited to the repair or replacement of its parts in accordance with the terms and conditions of these warranties.
7. **Limitation of Damages:** Under no circumstances shall U.S. Boiler Company, Inc. be liable for incidental, indirect, special or consequential damages of any kind whatsoever under these warranties, including, but not limited to, injury or damage to persons or property and damages for loss of use, inconvenience or loss of time. U.S. Boiler Company, Inc. liability under these warranties shall under no circumstances exceed the purchase price paid by the owner for the residential grade boiler involved. Some states do not allow the exclusion or limitation of incidental or consequential damages, so the above limitation or exclusion may not apply to you.
8. **Limitation of Warranties:** These warranties set forth the entire obligation of U.S. Boiler Company, Inc. with respect to any defect in a residential grade boiler, parts, or accessories and U.S. Boiler Company, Inc. shall have no express obligations, responsibilities or liabilities of any kind whatsoever other than those set forth herein. These warranties are given in lieu of all other express warranties.

ALL APPLICABLE IMPLIED WARRANTIES, IF ANY, INCLUDING ANY WARRANTY OF MERCHANTABILITY OR FITNESS FOR A PARTICULAR PURPOSE ARE EXPRESSLY LIMITED IN DURATION TO A PERIOD OF ONE YEAR EXCEPT THAT IMPLIED WARRANTIES, IF ANY, APPLICABLE TO THE HEAT EXCHANGER IN A RESIDENTIAL GRADE BOILER SHALL EXTEND TO THE ORIGINAL OWNER FOR THE TIME SPECIFIED IN THE HEAT EXCHANGER SECTION SHOWN ABOVE AT THE ORIGINAL PLACE OF INSTALLATION. SOME STATES DO NOT ALLOW LIMITATION ON HOW LONG AN IMPLIED WARRANTY LASTS, SO THE ABOVE LIMITATION MAY NOT APPLY TO YOU.

PROCEDURE FOR OBTAINING WARRANTY SERVICE

In order to assure prompt warranty service, the owner is requested to complete and mail the Warranty Card provided with the product or register product online at www.usboiler.burnham.com within ten days after the installation of the boiler, although failure to comply with this request will not void the owner's rights under these warranties. Upon discovery of a condition believed to be related to a defect in material or workmanship covered by these warranties, the owner should notify the installer, who will in turn notify the distributor. If this action is not possible or does not produce a prompt response, the owner should write to U.S. Boiler Company, Inc., Attn: Customer Service, P.O. Box 3079, Lancaster, PA 17604, giving full particulars in support of the claim. The owner is required to make available for inspection by U.S. Boiler Company, Inc. or its representative the parts claimed to be defective and, if requested by U.S. Boiler Company, Inc. to ship these parts prepaid to U.S. Boiler Company, Inc. at the above address for inspection or repair. In addition, the owner agrees to make all reasonable efforts to settle any disagreement arising in connection with a claim before resorting to legal remedies in the courts.

THIS WARRANTY GIVES YOU SPECIFIC LEGAL RIGHTS AND YOU MAY ALSO HAVE OTHER RIGHTS WHICH VARY FROM STATE TO STATE.



U.S. Boiler Company, Inc., P.O. Box 3020, Lancaster, PA 17604