

# Installation, Operating and Service Instructions for

# V8H™

Residential Water

- Water Boiler
- Natural Draft
- Oil-Fired
- B20 Ready

### Models:

- V8H3WE
- V8H3WEH
- V8H3WE-T
- V8H4WE
- V8H4WEH
- V8H4WE-T
- V8H5WE
- V8H5WEH
- V8H5WE-T
- V8H6WE
- V8H6WEH
- V8H6WE-T
- V8H7WE
- V8H7WEH
- V8H7WE-T

### Manual Contents

### Page

1. Dimensional Description, Specification & Dimensional Data . . . . .	4
2. Pre-installation . . . . .	8
3. Knock Down Boiler Assembly . . . . .	10
4. Packaged Boiler Assembly . . . . .	17
5. Water Boiler Piping & Trim . . . . .	21
6. Tankless & Indirect Water Heater Piping. . . . .	25
7. Venting & Air Intake Piping . . . . .	27
8. Electrical . . . . .	31
9. Oil Piping. . . . .	36
10. System Start-Up. . . . .	38
11. Operating. . . . .	41
12. Service and Maintenance . . . . .	51
13. Boiler Cleaning . . . . .	53
14. Troubleshooting . . . . .	55
15. Service Parts . . . . .	58
16. Burner Specifications . . . . .	64
Appendix . . . . .	65



### TO THE INSTALLER:

Affix these instructions adjacent to boiler.

### TO THE CONSUMER:

Retain these instructions for future reference.

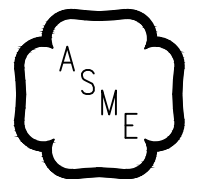

Intertek  
9700609



For service or repairs to boiler, call your heating contractor. When seeking information on boiler, provide Boiler Model Number and Serial Number as shown on Rating Label.

---

**IMPORTANT INFORMATION - READ CAREFULLY**

---

All boilers must be installed in accordance with National, State and Local Plumbing, Heating and Electrical Codes and the regulations of the serving utilities. These Codes and Regulations may differ from this instruction manual. Authorities having jurisdiction should be consulted before installations are made.

In all cases, reference should be made to the following Standards:

**USA BOILERS**

- A. Current Edition of American National Standard ANSI/NFPA 31, “Installation of Oil Burning Equipment”; for recommended installation practices.
- B. Current Edition of American National Standard ANSI/NFPA 211, “Chimneys, Fire places, Vents, and Solid Fuel Burning Appliances”; For Venting requirements.
- C. Current Edition of American Society of Mechanical Engineers ASME CSD-1, “Controls and Safety Devices for Automatically Fired Boilers”; for assembly and operations of controls and safety devices.
- D. All wiring on boilers installed in the USA shall be made in accordance with the National Electrical Code and/or Local Regulations.

The following terms are used throughout this manual to bring attention to the presence of hazards of various risk levels, or to important information concerning product life.

**⚠ DANGER**

Indicates a hazardous situation that, if not avoided, will result in death or serious injury.

**⚠ CAUTION**

Indicates a hazardous situation that, if not avoided, could result in minor or moderate injury.

**⚠ WARNING**

Indicates a hazardous situation that, if not avoided, could result in death or serious injury.

**NOTICE:** Indicates special instructions on installation, operation, or service which are important but not related to personal injury hazards.

**NOTICE:** This boiler has a limited warranty, a copy of which is included with this boiler. The warranty for this boiler is valid only if the boiler has been installed, maintained and operated in accordance with these instructions.

Surface rust on cast iron sections may be attributed to the manufacturing process as well as condensation during storage. Surface rust is normal and does not affect the performance or longevity of a boiler.

**⚠ DANGER**

DO NOT store or use gasoline or other flammable vapors or liquids in the vicinity of this or any other appliance.

**⚠ WARNING**

Improper installation, adjustment, alteration, service or maintenance can cause property damage, personal injury or loss of life. Failure to follow all instructions in the proper order can cause personal injury or death. Read and understand all instructions, including all those contained in component manufacturers manuals which are provided with the boiler before installing, starting-up, operating, maintaining or servicing this boiler. Keep this manual and literature in legible condition and posted near boiler for reference by owner and service technician.

- This boiler requires regular maintenance and service to operate safely. Follow the instructions contained in this manual.
- Installation, maintenance, and service must be performed only by an experienced, skilled and knowledgeable installer or service agency.
- All heating systems should be designed by competent contractors and only persons knowledgeable in the layout and installation of hydronic heating systems should attempt installation of any boiler.
- Installation is not complete unless a pressure relief valve is installed into the tapping located on top left corner of front section- See Piping and Trim Sections of this manual for details.
- It is the responsibility of the installing contractor to see that all controls are correctly installed and are operating properly when installation is complete including verifying that the limit sensor is fully installed (seated in bottom of Well).
- Failure to properly install Limit Sensor may result in property damage, personal injury or loss of life due to elevated operating temperatures and/or pressures.
- This boiler is suitable for installation on combustible flooring. Do not install boiler on carpeting.
- Do not tamper with or alter the boiler or controls.
- Inspect flueways at least once a year - preferably at the start of the heating season. The inside of the combustion chamber, the vent system and boiler flueways should be cleaned if soot or scale has accumulated.
- When cleaning this boiler, DO NOT damage combustion chamber liner and/or rear target wall. If damaged, combustion chamber insulation must be replaced immediately.
- Oil Burner and Controls must be checked at least once a year or as may be necessitated.
- Do not operate boiler with jumpered or absent controls or safety devices.
- Do not operate boiler if any control, switch, component, or device has been subject to water.
- Boiler materials of construction, products of combustion and the fuel contain alumina, silica, heavy metals, carbon monoxide, nitrogen oxides, aldehydes and/or other toxic or harmful substances which can cause death or serious injury and which are known to the state of California to cause cancer, birth defects and other reproductive harm. Always use proper safety clothing, respirators and equipment when servicing or working nearby the boiler.

**⚠ WARNING**

This boiler contains very hot water under high pressure. Do not unscrew any pipe fittings nor attempt to disconnect any components of this boiler without positively assuring the water is cool and has no pressure. Always wear protective clothing and equipment when installing, starting up or servicing this boiler to prevent scald injuries. Do not rely on the pressure and temperature gauges to determine the temperature and pressure of the boiler. This boiler contains components which become very hot when the boiler is operating. Do not touch any components unless they are cool.

- High water temperatures increase the risk of scalding injury. If this boiler is equipped with a tankless heater for domestic water supply, a flow regulator and automatic mixing valve must be installed properly in tankless heater piping. See Piping and Trim Sections of this manual for details.
- This boiler must be properly vented and connected to an approved vent system in good condition. DO NOT operate boiler with the absence of an approved vent system.
- This boiler needs fresh air for safe operation and must be installed so there are provisions for adequate combustion and ventilation air.
- A clean and unobstructed chimney flue is necessary to allow noxious fumes that could cause injury or loss of life to vent safely and will contribute toward maintaining the boiler's efficiency.
- This boiler is supplied with controls which may cause the boiler to shut down and not re-start without service. If damage due to frozen pipes is a possibility, the heating system should not be left unattended in cold weather; or appropriate safeguards and alarms should be installed on the heating system to prevent damage if the boiler is inoperative.
- This boiler is designed to burn No. 2 fuel oil including bio blends not exceeding 20% Bio Diesel (ASTM D396) only.
  - DO NOT USE with Flammable Liquids, Gasoline, Crankcase drainings, charcoal lighter fluid, or any oil containing gasoline.
  - DO NOT convert to any solid fuel (i.e., wood, coal).
  - DO NOT convert to any gaseous fuel (i.e., natural gas, LP).
  - DO NOT USE Raw Vegetable Oil (RVO) or any fuel blended with RVO
  - Use of untested/uncertified fuels could result in explosion, fire, personal injury, or death, and/or damage to equipment and property.
  - Never burn garbage or paper in this boiler.
- All flammable debris, rags, paper, woodscraps, etc., should be kept clear of the boiler at all times. Keep the boiler area clean and free of fire hazards.
- All boilers equipped with burner swing door have a potential hazard which, if ignored, can cause severe property damage, personal injury or loss of life. Before opening swing door turn off service switch to boiler to prevent accidental firing of burner outside the combustion chamber. Be sure to tighten swing door fasteners completely when service is completed.

## 1 Product Description, Specification and Dimensional Data

The V8H Series boiler is a cast iron oil-fired water boiler designed for closed forced circulation heating systems. This boiler must be vented by natural draft into a fireclay tile-lined masonry chimney or chimney constructed from type L vent or a factory built chimney that complies with the type HT requirements of UL103. An adequate supply of air for combustion, ventilation and dilution of flue gases must be available in the boiler room.

### Water Boilers

The V8H Series water boiler uses an Intelligent Oil Boiler Control (boiler control). The boiler control replaces the traditional electronic aquastat and circulator relays and adds energy saving thermal purge features. Energy is saved by starting the circulator and delaying the burner start when there is residual heat available in the boiler. A Warm Start Intelligent Oil Boiler Control (Warm Start Boiler Control) is included with a tankless heater option to generate domestic hot water.

# 1 Product Description, Specification and Dimensional Data *(continued)*

**Table 1-1: Dimensional Data (See Figures 1-3 and 1-4)**

Boiler Series	Dimensions See Figures 1-3 and 1-4			Water Content - Gallons	Approximate Shipping Weight (LB.)
	"A"	"B"	"C"		
V8H3WE	17-1/8 in.	9-1/8 in.	6 in.	12.8	542
V8H4WE	22-1/8 in.	11-5/8 in.	6 in.	15.7	634
V8H5WE	27-1/8 in.	14-1/8 in.	7 in.	18.5	726
V8H6WE	32-1/8 in.	16-5/8 in.	7 in.	21.4	818
V8H7WE	37-1/8 in.	19-1/8 in.	8 in.	24.2	910

NOTE 1: Maximum working Pressure: Water: 30 PSI Shipped From Factory (Std.), 40 PSI Optional, 50 PSI Optional

**Table 1-2: Rating Data**

Boiler Series	Burner Capacity		Heating Capacity <sup>(2)</sup>	AHRI NET Ratings <sup>(3)</sup>	AFUE %	Minimum Chimney Requirements		
	GPH	MBH <sup>(1)</sup>	MBH	Water MBH		Round in Dia.	Rectangle In. X In.	Height Ft.
V8H3WE	1.00	140	120	104	86.0	6	8 x 8	15
V8H4WE	1.20	170	148	129	86.1	6	8 x 8	15
V8H5WE	1.65	231	200	174	86.0	7	8 x 8	15
V8H6WE	1.90	266	230	200	86.0	7	8 x 8	15
V8H7WE	2.10	294	255	222	86.1	8	8 x 8	15

<sup>(1)</sup> MBH refers to thousands of BTU per hour.

<sup>(2)</sup> Based on standard test procedure prescribed by the United States Department of Energy at combustion conditions of 13.0% CO<sub>2</sub>.

<sup>(3)</sup> Net AHRI Ratings are based on piping and pickup allowance of 1.15 for water.

Note: The rating shown are based on the use of #2 Heating Oil.



# 1 Product Description, Specification and Dimensional Data *(continued)*

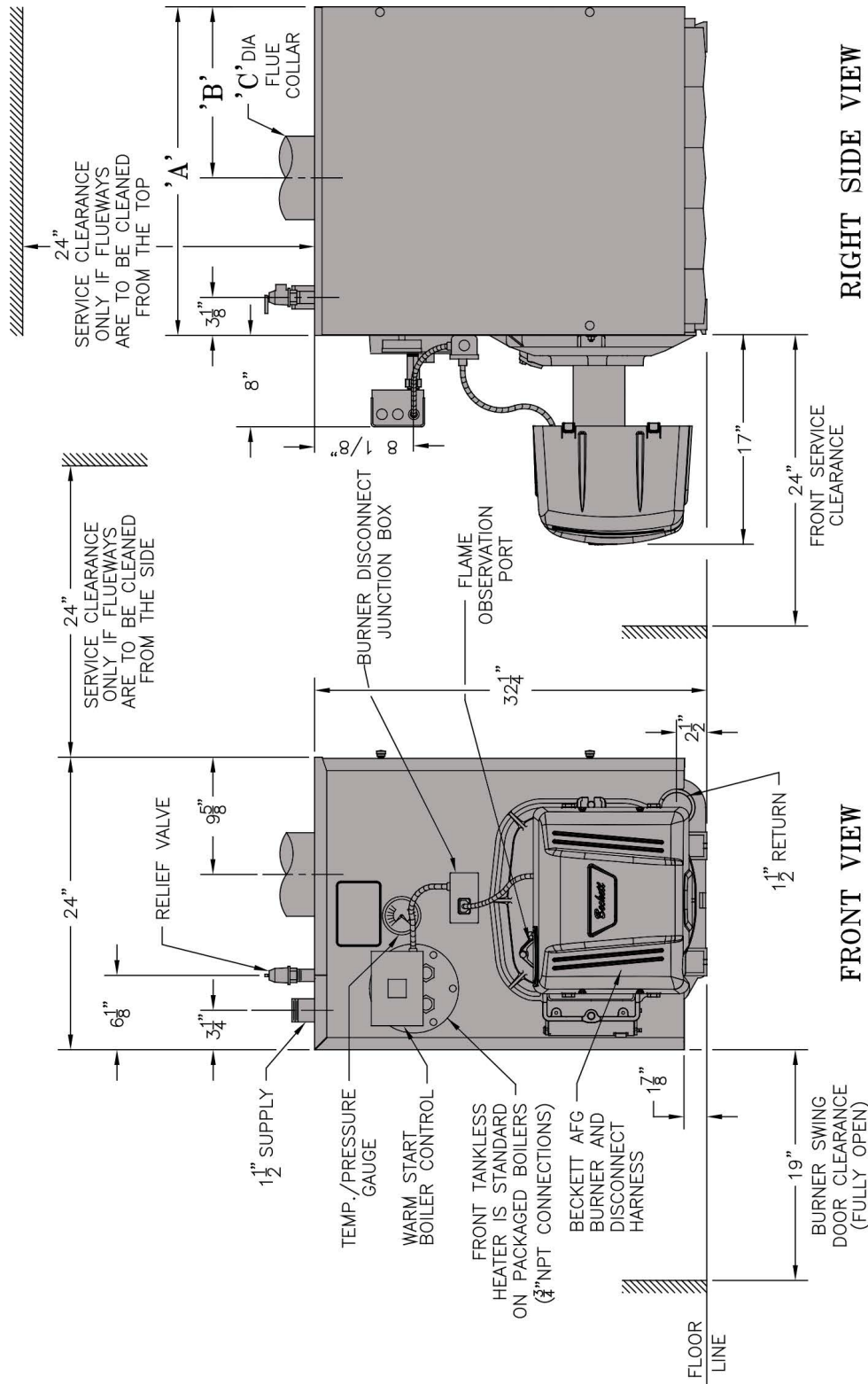

NOTES:  
 1. WIRING HARNESES, RETURN PIPING AND CIRCULATOR NOT FURNISHED WITH KNOCKDOWN BOILERS.

Figure 1-4: Water Boiler with Front Tankless Heater

## 2 Pre-Installation

### A. **INSPECT SHIPMENT** carefully for any signs of damage.

1. All equipment is carefully manufactured, inspected and packed. Our responsibility ceases upon delivery of crated boiler to the carrier in good condition.
2. Any claims for damage or shortage in shipment must be filed immediately against the carrier by the consignee. No claims for variances from, or shortage in orders, will be allowed by the manufacturer unless presented within sixty (60) days after receipt of goods.

### B. **LOCATE BOILER** in front of final position before removing crate. See Figures 1-3 and 1-4.

1. LOCATE so that vent pipe connection to chimney will be short and direct.
2. BOILER IS SUITABLE FOR INSTALLATION ON COMBUSTIBLE FLOOR. Boiler cannot be installed on carpeting.

3. FOR BASEMENT INSTALLATION, provide a solid elevated base, such as concrete, if floor is not level, or if water may be encountered on floor around boiler.
4. PROVIDE SERVICE CLEARANCE of at least 24 in. clearance from front jacket panel for servicing and removal of front tankless heater. If boiler is equipped with a rear tankless heater, provide at least 24 in. service clearance on the right side of the boiler. Boiler flueways may be cleaned either from the top or from the right side. Provide at least 24 in. clearance from either the right side of the boiler or the top of the boiler for cleaning flueways.
5. For minimum clearances to combustibles materials. See Figure 2-1.

### C. **PROVIDE COMBUSTION AND VENTILATION**

**AIR.** Local and National Codes may apply and should be referenced.

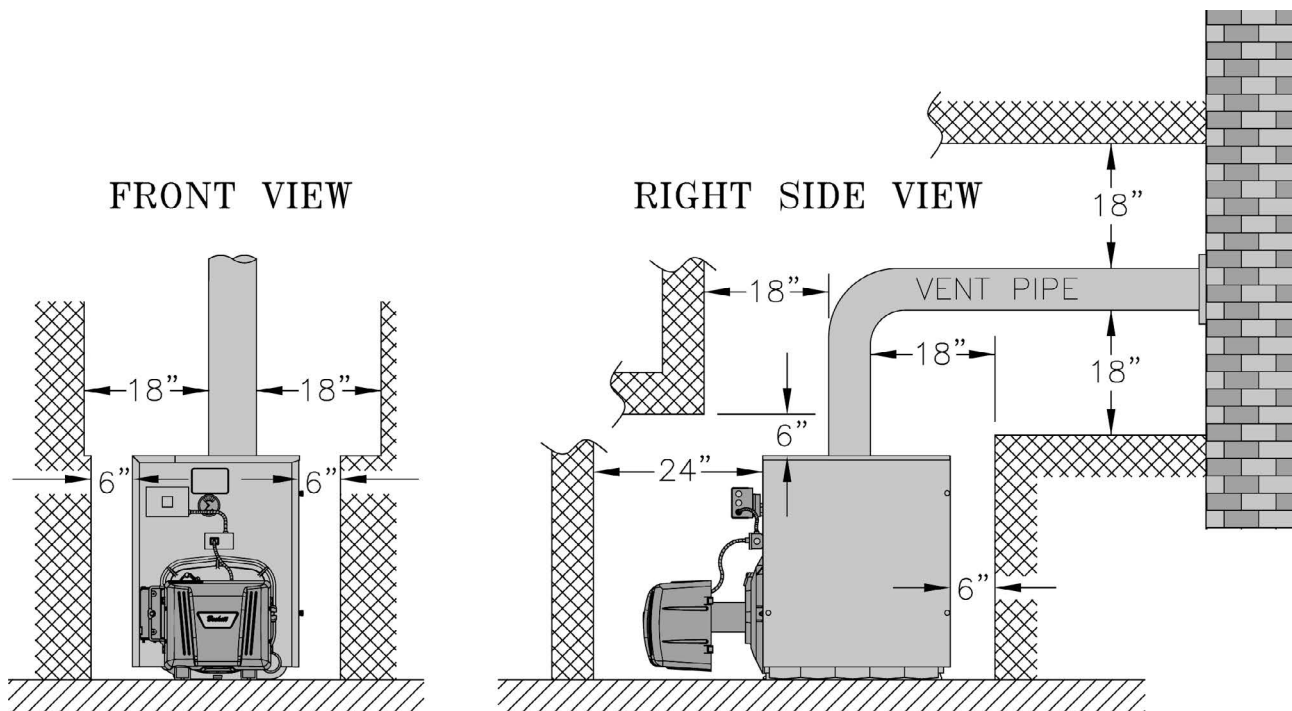

**Figure 2-1: Minimum Installation Clearances To Combustible Materials (Inches)**

#### NOTES:

1. Listed clearances comply with American National Standard ANSI/NFPA 31, Installation of Oil Burning Equipment.
2. V8H Series boilers can be installed in rooms with clearances from combustible material as listed above. Listed clearances cannot be reduced for alcove or closet installations.
3. For reduced clearances to combustible material, protection must be provided as described in the above ANSI/NFPA 31 standard.

## 2 Pre-Installation *(continued)*

**NOTICE:** Clearance to venting is for single wall vent pipe. If Type L vent is used, clearance may be reduced to the minimum required by the vent pipe manufacturer.

### WARNING

Adequate combustion and ventilation air must be provided to assure proper combustion and to maintain safe ambient air temperatures.

**DO NOT** install boiler where gasoline or other flammable vapors or liquids, or sources of hydrocarbons (i.e. bleaches, fabric softeners, etc.) are used or stored.

1. Determine volume of space (boiler room). Rooms communicating directly with the space in which the appliances are installed, through openings not furnished with doors, are considered a part of the space.  

$$\text{Volume(ft.}^3\text{)} = \text{Length(ft.)} \times \text{Width(ft.)} \times \text{Height(ft.)}$$
2. Determine total input of all appliances in the space.  
 Add inputs of all appliances in the space and round the result to the nearest 1000 BTU per hour.
3. Determine type of space. Divide Volume by total input of all appliances in space. If the result is greater than or equal to 50 ft.<sup>3</sup>/1000 BTU per hour, then it is considered an *unconfined space*. If the result is less than 50 ft.<sup>3</sup>/1000 BTU per hour then the space is considered a *confined space*.
4. For boiler located in an *unconfined space of a conventionally constructed building*, the fresh air infiltration through cracks around windows and doors normally provides adequate air for combustion and ventilation.
5. For boiler located in a confined space or an unconfined space in a building of unusually tight construction, provide outdoor air.
  - a. Outdoor air for combustion may be provided with an optional U.S. Boiler Company V8H™ Fresh Air Accessory Kit (**ONLY AVAILABLE ON BECKETT BURNERS WITH PLASTIC COVER APPLICATION, P/N 102119-01**). Refer to Fresh Air Accessory Kit Instructions for installation and air intake piping details.

**or**

- b. Outdoor air may be provided with the use of two permanent openings which communicate directly or by duct with the outdoors or spaces (crawl or attic) freely communicating with the outdoors. Locate one opening within 12 inches of top of space. Locate remaining opening within 12 inches of bottom of space. Minimum dimension of air opening is 3 inches. Size each opening per following:
    - i. **Direct communication with outdoors.** Minimum free area of 1 square inch per 4,000 BTU per hour input of all equipment in space.
    - ii. **Vertical ducts.** Minimum free area of 1 square inch per 4,000 BTU per hour input of all equipment in space. Duct cross-sectional area shall be same as opening free area.
    - iii. **Horizontal ducts.** Minimum free area of 1 square inch per 2,000 BTU per hour input of all equipment in space. Duct cross-sectional area shall be same as opening free area.  
*Alternate method for boiler located within confined space.* Use indoor air if two permanent openings communicate directly with additional space(s) of sufficient volume such that combined volume of all spaces meet criteria for unconfined space. Size each opening for minimum free area of 1 square inch per 1,000 BTU per hour input of all equipment in spaces, but not less than 100 square inches.
6. Louvers and Grilles of Ventilation Ducts
    - a. All outside openings should be screened and louvered. Screens used should not be smaller than 1/4 inch mesh. Louvers will prevent the entrance of rain and snow.
    - b. Free area requirements need to consider the blocking effect of louvers, grilles, or screens protecting the openings. If the free area of the louver or grille is not known, assume wood louvers have 20-25 percent free area and metal louvers and grilles have 60-75 percent free area.
    - c. Louvers and grilles must be fixed in the open position, or interlocked with the equipment to open automatically during equipment operation.

### 3 Knock Down Boiler Assembly

#### A. REMOVAL OF BARE BOILER FROM SKID

1. Boiler is secured to skid with 4 bolts, 2 in front and 2 in rear of shipping skid, see Figure 3-1. Remove all bolts.

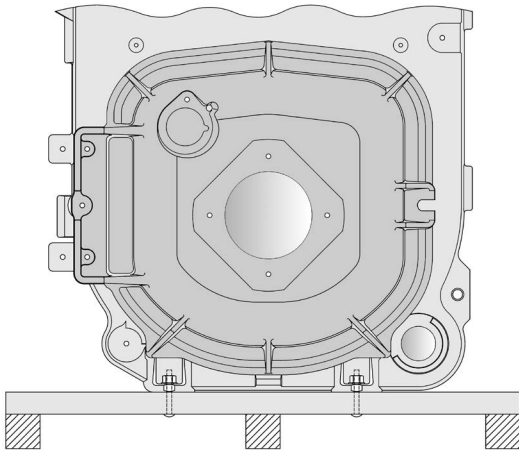

Figure 3-1: Knockdown Boiler Removal from Skid

2. Tilt boiler to right and to rear. Using right rear leg as pivot, rotate boiler 90° in a clockwise direction, and lower left side of boiler to floor. Tilt boiler and remove skid.

#### B. MOVE BOILER TO PERMANENT POSITION

 by sliding or walking.

#### C. TEST BOILER FOR LEAKS

 before installing controls, trim, and jacket, and before connecting to heating system.

1. Loosen nuts on tie rods until only finger tight.
2. Install pressure gauge (at least 50 PSI capacity), a hose to the city water and a valve in the supply tapping. Plug remainder of tappings.
3. Fill boiler with water and apply a pressure of at least 10 PSI but no more than 50 PSI gauge pressure.

#### ⚠ WARNING

Assure that there is not air left inside boiler when checking for leaks. **DO NOT** test for leaks with pressurized air.

4. Examine boiler carefully inside and outside for leaks or damage due to shipment or handling.

#### D. DRAIN WATER FROM BOILER.

 Remove gauge, valve and plugs from those tappings to be used. Leave other tappings plugged or bushed according to Figure 3-3.

#### E. INSPECT JOINTS BETWEEN SECTIONS.

 All joints are factory sealed. If there are any spaces due to shipment or handling, seal them with boiler putty.

#### F. INSPECT FLUE COVER PLATES

 for tightness. If loose, retighten mounting hardware. If flue plate or sealing rope is damaged, repair or replace as

Figure 3-2: Boiler Canopy Installation

#### G. INSTALL FLUE BAFFLES

1. Insert one (1) Flue Baffle into each flue way.

#### H. INSTALL AND SECURE CANOPY

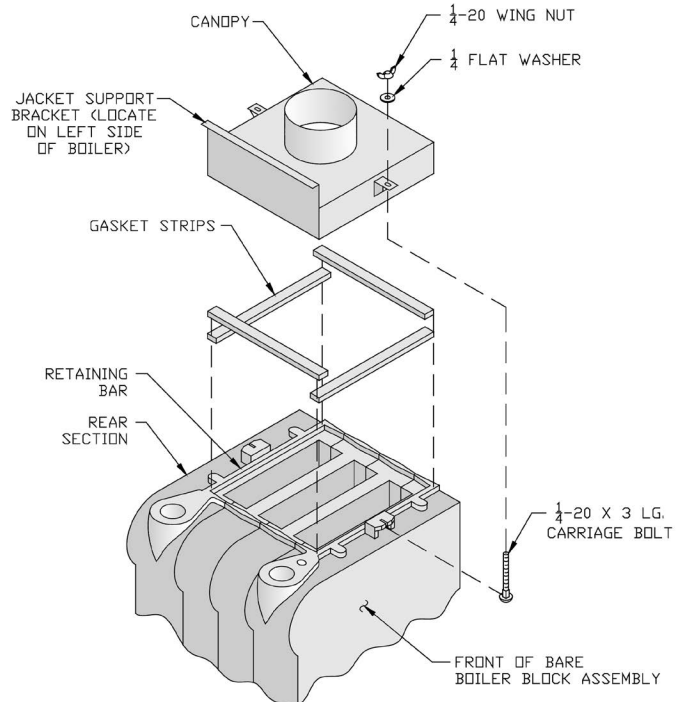
 with gasket and hardware provided to ensure gas tight seal — see Figure 3-2.

1. Cut two (2) strips 13 3/4 in. long from the roll of gasket insulation. Place one (1) strip across the top of the front section and the other across the rear section as shown in Figure 3-2.
2. Cut the remainder of the roll into two (2) equal pieces. Place each piece along the sides, allowing the ends to overlap the front and rear pieces.

#### ⚠ CAUTION

**DO NOT** allow any flueway blockage by gasket.

3. Position canopy body within the retaining bar which borders the flueway openings on top of the bare boiler assembly.

**NOTICE:** Jacket support bracket must be facing left side of boiler - see Figure 3-2. Jacket will not fit if bracket is not oriented correctly.

4. Secure canopy to boiler with two (2) 1/4 in. - 20 x 3 in. long carriage bolts, 1/4 in. flat washers and 1/4 in. - 20 wing nuts provided.

### 3 Knock Down Boiler Assembly *(continued)*

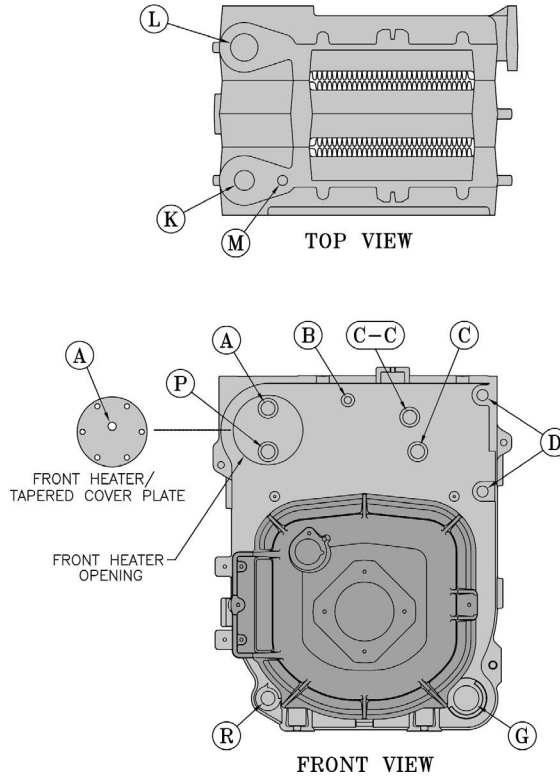
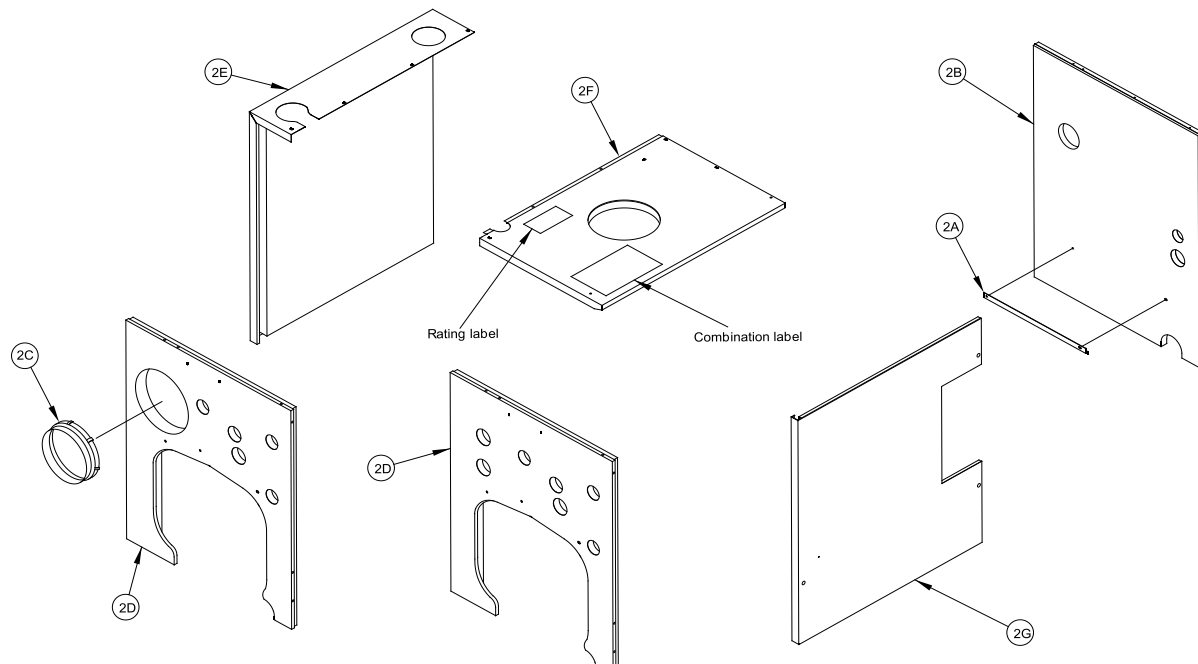

**Figure 3-3: Boiler Tapping Locations and Usage (Knockdown Boilers Only)**

PURPOSE OF TAPPINGS			
Tapping Location	Size NPT	Water Boiler	
		Non-Heater	Front Heater
A	3/4 in.	Boiler Control	Boiler Control
B	1/4 in.	Temperature/Pressure Gauge	
C	3/4 in.	N/A	
C-C	3/4 in.	N/A	
D	1/2 in.	N/A	
G	1 1/2 in.	Return	
H	1 1/2 in.	Plugged	
J	1 1/2 in.	Flush Plug	
K	2 in.	Front Supply	
L	2 in.	Plugged	
M	3/4 in.	Relief Valve	
P	3/4 in.	Aux. Tapping - Plugged	N/A
R	3/4 in.	Auxiliary Tapping - Plugged	
S	1/2 in.	N/A	
T	1 in.	N/A	

\* In lieu of Tankless Heater

### 3 Knock Down Boiler Assembly *(continued)*



**Figure 3-4: Knockdown Boiler Jacket Assembly**

**I. INSTALL TRIM.** The following water trim will be concealed or inaccessible after boiler jacket is installed, see Figure 3-3 for boiler tapping locations and usage.

1. **WATER BOILER** — Top tapplings:

- Tapping "L" — Install 2 in. NPT plug in rear section top supply tapping — all boiler sizes.
- Tapping "M" — Install ¾ in. NPT x 8 in. long nipple into ¾ in. NPT tapping located next to front section top supply tapping — all boiler sizes.

**J. INSTALL COMBUSTION CHAMBER RING/PLATE**

- Open burner swing door. Remove one (1) 5/16 in. -18 flange nut and washer from right side latching stud and one (1) 5/16 in.- 18 x 3½ in. cap screw on left side used for securing burner swing door to the boiler section. Swing door open.
- The V8H3WE utilizes a combustion chamber ring. To install, place the combustion chamber ring in the center of the combustion chamber. The horizontal supports will center and position the combustion chamber ring towards the front of the combustion chamber. See Figure 3-6.
- The V8H5WE utilizes a combustion chamber plate. To install, place the combustion chamber plate in the center of the front section.

**K. INSTALL BOILER JACKET.** (See Figure 3-4).

- Install jacket rear panel support bracket. (See

Figure 3-4, Item 2A). Align bracket with two (2) 5/16 in.-18 tapped holes in rear section and secure with two (2) 5/16 in.-18 x 1/2 in. long cap screws.

- Install jacket rear panel. (See Figure 3-4, Item 2B). Align holes in jacket rear panel and support bracket. Secure with two (2) #8 x 1/2 in. long sheet metal screws.
- Jacket Front Panel
  - Install black plastic collar extension to jacket front panels for 7-13/16 in. diameter tankless heater opening. (See Figure 3-4, Items 2C and 2D). Engage two (2) of the collar retaining tabs over raw edge of jacket opening. Provide support behind the panel with one hand while applying pressure on collar to snap each tab over edge of opening until all eight (8) tabs are securing collar.
  - Install jacket front panel. Locate two (2) 11/32 in. diameter holes, one round, one obround, on front panel approximately 16 in. up from the bottom of the panel. Align these holes with the similarly located 5/16 in.-18 tapplings on the front section. Secure with two (2) 5/16 in.-18 x 1/2 in. long cap screws.
- Install jacket left side panel. (See Figure 3-4, Item 2E). Fold panel at perforation keeping insulation inward. Align left side panel mounting holes with the front and rear panel holes. Secure with #8 x 1/2 in. long sheet metal screws.

### 3 Knock Down Boiler Assembly *(continued)*

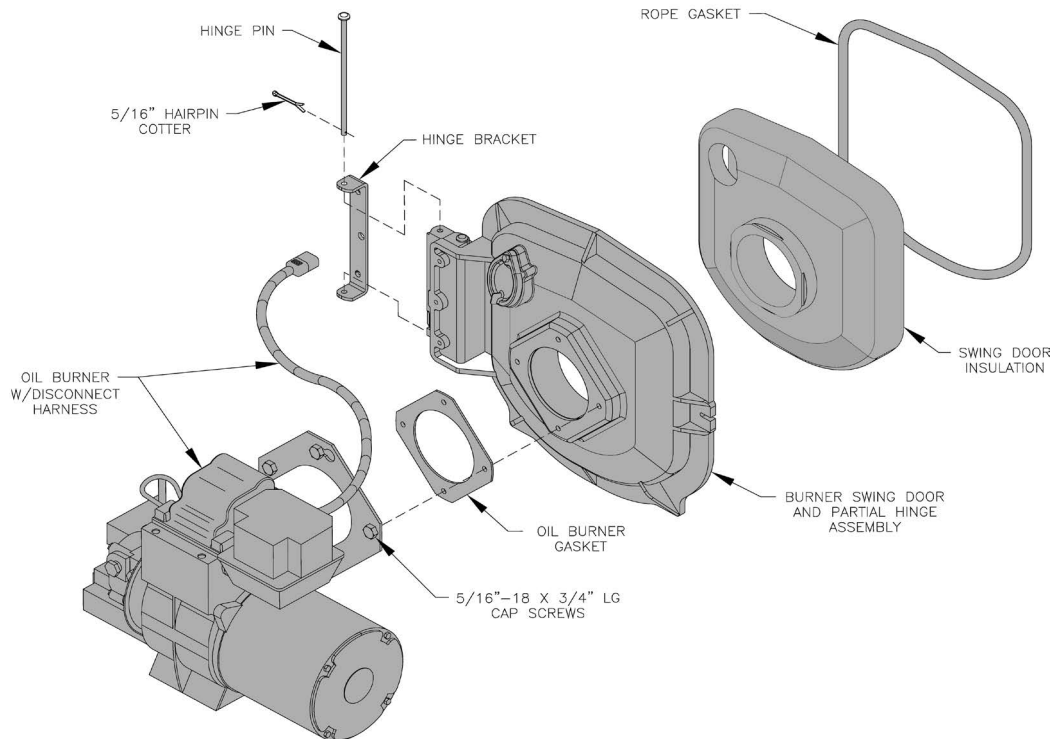

**Figure 3-5: Oil Burner Installation (Beckett Burner Shown)**

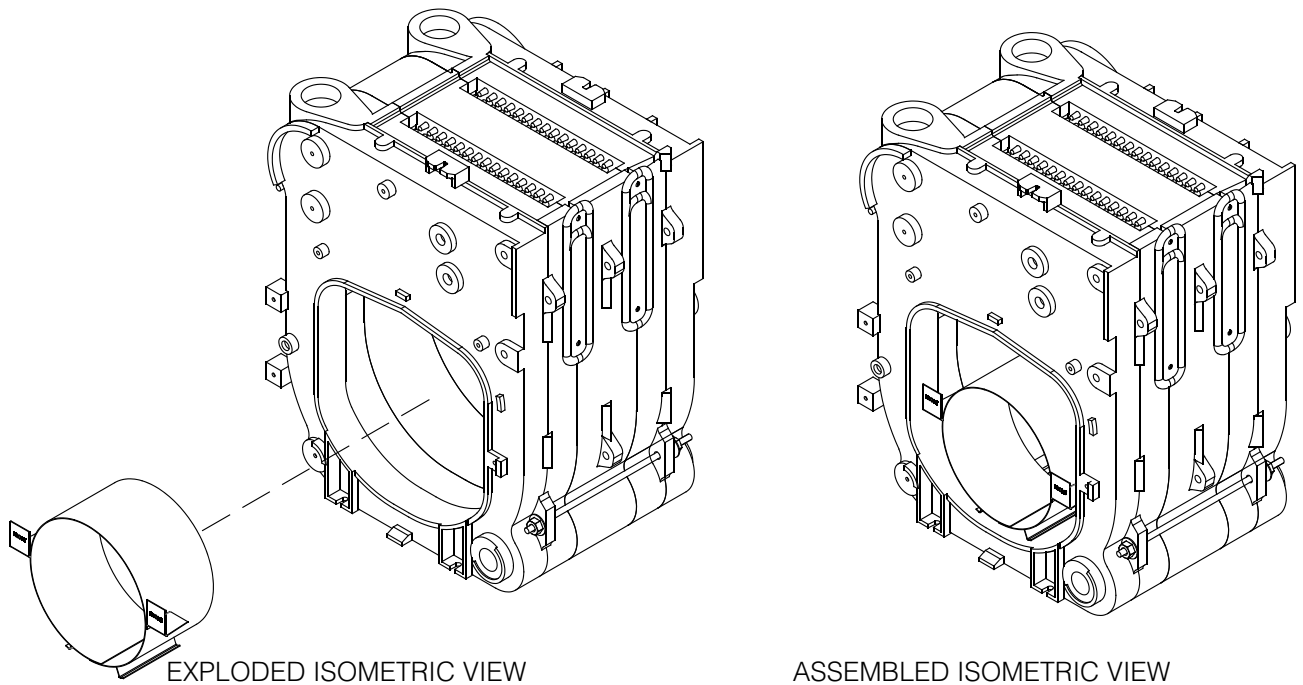

**Notes:**

1. Jacket and Burner Swing Door have been removed for clarity.

**Figure 3-6: Combustion Chamber Ring Installation**

### 3 Knock Down Boiler Assembly *(continued)*

5. Install jacket top panel. (See Figure 3-4, Item 2F). Place jacket top panel on boiler and secure to front, rear and left side panels with #8 x 1/2 in. long sheet metal screws.
6. Install jacket right side access panel. (See Figure 3-4, Item 2G). Align right side panel mounting holes with front and rear panel holes. Secure with #8 x 1/2 in. long sheet metal screws.
7. Attach the labels shipped in the instruction envelope as follows:
  - a. Locate both the Rating Label and Combination Warning Label (P/N 102801-03). Remove paper backing from the labels and apply to the jacket top panel in approximate locations shown in (Figure 3-4, Item 2F).

#### L. **INSTALL BURNER.**

(See Figure 3-5).

1. Check target wall and combustion chamber blanket. If any damage or movement occurred during shipment, replace as needed.
2. Locate burner swing door and hinge assembly removed in Paragraph J, No. 1. Check the burner swing door insulation and rope gasket for damage and adhesion. If damaged, replace insulation or gasket. If insulation or gasket is loose, reattach to swing door with RTV 732 or 736 silicone caulk.
3. Install burner swing door in reverse order from Paragraph J, No. 1.
4. Use the following procedure to properly close and secure the burner swing door after it has been removed and re-installed for Field Assembly (Knockdown Boiler) or opened for inspection, cleaning or field service (refer to Figures 4-2 and 4-3):

**Step 1.** Lift the door up onto the built-in cast ramp/door rest (protruding from the bottom of the front section casting - see Figure 4-2), while rotating the articulated hinge and door to the right and engaging the slot (on right side of door) unto the 5/16 in. stud protruding from the front section.

**Step 2.** Use one hand to help hold door in position by applying pressure directly to the door while re-installing the securing hardware with your opposite hand. **Always install right side latching hardware (5/16 in. flange nut and flat washer) first, then install left side hinge hardware (5/16 in. x 3-1/2 in. lg. hex head flange bolt) second.** Apply additional pressure while hand

tightening the hardware as far as possible, then release the pressure.

**NOTICE:** When securing burner swing door make sure door is drawn-in equally on both sides.

**Step 3.** Use a hand wrench to tighten door hardware and **always start with the right side flange nut first** (see Figure 4-3). Use an alternating tightening method from right side flange nut to left side flange bolt to tighten door equally until sealed without applying excessive torque. **Never** tighten left side flange bolt first or tighten either piece of hardware 100% without using the alternating tightening method described above.

Failure to follow the prescribed procedure could cause thread damage to casting or a leak in the door seal. If left side flange bolt is tightened before right side flange nut, right side of door can not be drawn-in to provide an air tight seal, as shown in Figure 4-4. Applying excessive torque will only cause thread damage.

5. Place oil burner gasket on burner and align holes.

#### CAUTION

DO NOT install burner without gasket.

6. Back out (4) 5/16 in. -18 x 3/4 in. long cap screws factory installed into burner swing door about 1/4 in. Insert oil burner into the opening of the burner door, rotate slightly clockwise to align burner mounting flange teardrop cutouts with cap screw hex heads and engage all four cap screws simultaneously. Then, rotate the burner slightly counterclockwise, level it and fully tighten all four cap screws.
7. Inspect electrodes, head setting and factory installed oil nozzle. Refer to the instructions provided with the burner and Table 16-1.

#### M. **INSTALL TRIM AND CONTROLS** (See Figures 1-3, 1-4, and 3-3).

1. Thread combination pressure/temperature gauge into 1/4 in. NPT tapping. Tighten with wrench applied to the square shank of the gauge.

#### CAUTION

DO NOT apply pressure to the gauge case - this may result in inaccurate readings.

### 3 Knock Down Boiler Assembly *(continued)*

2. Lower front section tapping "G" is used for standard return on water boilers, see Figure 5. If circulator (supplied with boiler) is to be mounted in return piping connected directly to 1½ in. NPT boiler return tapping "G", use the piping arrangements outlined in steps a. thru e. as follows: (see Figures 5-2 and 5-3).
  - a. Thread 1½ in. NPT x 3 in. long nipple and 1½ in. NPT x 90° elbow with ¾ in. NPT side outlet into the return tapping and tighten with a pipe wrench.
  - b. Screw drain valve into ¾ in. NPT side outlet of the 1½ in. NPT x 90° elbow.
  - c. Thread 1½ in. NPT x 18 in. long nipple (supplied by others) into the 1½ in. NPT x 90° elbow and tighten with a pipe wrench.
  - d. Thread one of the circulator flange onto the nipple and tighten with a pipe wrench. Position flange so that the bolt slots are parallel to the boiler front.
  - e. Place a circular flange gasket in the flange groove on the circulator and mount the circulator on the flange. Note that this is the return piping and the flow arrow on the circulator should point down ↓ Fasten circulator with 7/16 in. - 14 x 1½ in. long cap screws and 7/16 in. - 14 nuts.
  - f. Fasten the second circulator flange and gasket to the circulator.
  - g. Remove supplied circulator harness from Part Bag. Remove circulator junction box cover and knockout in circulator junction box flange. Insert harness end with two wires having bare-stripped ends through knockout hole and push-in to engage harness connector into flange. Connect harness conductors to circulator junction box wires as follows - White to White and Blue to Yellow (or, Blue) and secure with wire nuts (installer provided).
3. Install relief valve, as shown in Figure 1-3 and 1-4 onto ¾ in. NPT x 8 in. nipple previously installed in Paragraph I, No. 2, step b. Tighten with wrench. Pipe discharge as shown in Figures 5-2 and 5-3. Installation of the relief valve must be consistent with ANSI/ASME Boiler and Pressure Vessel Code, Section IV.

#### WARNING

Safety valve discharge piping must be piped near floor to eliminate potential of severe burns. DO NOT pipe in any area where freezing could occur. DO NOT install any shut-off valves, plugs or caps.

4. On boilers without a heater opening, install the well into the 3/4 in. NPT tapping "A" located on the front of the boiler in the upper left corner. See Figures 1-3 and 3-3. Tighten the well and fully insert limit sensor into immersion well such that the tip on the limit sensor touches the bottom of the immersion well. See Figure 3-7. Secure control to immersion well with setscrew.

#### WARNING

Aquastat bulb must be fully inserted into the well.

5. On boilers with a heater opening, install the well in either the 1/2 in. NPT or 3/4 in. NPT tapping on the tankless heater plate or cover plate. See Figures 1-4, and 3-3. Tighten the well and fully insert limit sensor into immersion well such that the tip on the limit sensor probe touches the bottom of the immersion well. See Figure 3-7. Secure control to immersion well with setscrew.
6. After control is installed and secured, remove control cover. Then, remove knockout located directly above factory connected limit harness on right side flange of control. Insert circulator harness end with attached fork terminals thru knockout hole and push-in to engage harness connector into flange. Connect wires to control terminals as follows - Blue to C1 and White to C2 and tighten securely. Re-install control cover.
7. Connect Field Wiring.
  - a. Water boilers without tankless heater. Connect the field wiring to the aquastat control. Make the wiring connections as shown on Figure 8-1 or 8-3.
  - b. Water boilers with front heater. Connect the field wiring to the aquastat control. Make the wiring connections as shown on Figure 8-2 or 8-3.
  - c. Refer to Paragraph N for details on use of burner disconnect junction box provided with all knockdown boiler builds.

### 3 Knock Down Boiler Assembly *(continued)*

#### N. **BURNERS SUPPLIED BY U.S. BOILER**

**COMPANY** utilize a burner disconnect harness that is pre-wired into the burner junction box and primary control. Packed in the canopy carton is the mating burner disconnect junction assembly and mounting hardware for use with these burners.

If you are using a burner with the disconnect harness, complete the following assembly instructions for mounting the mating burner disconnect junction box, see Figure 3-8.

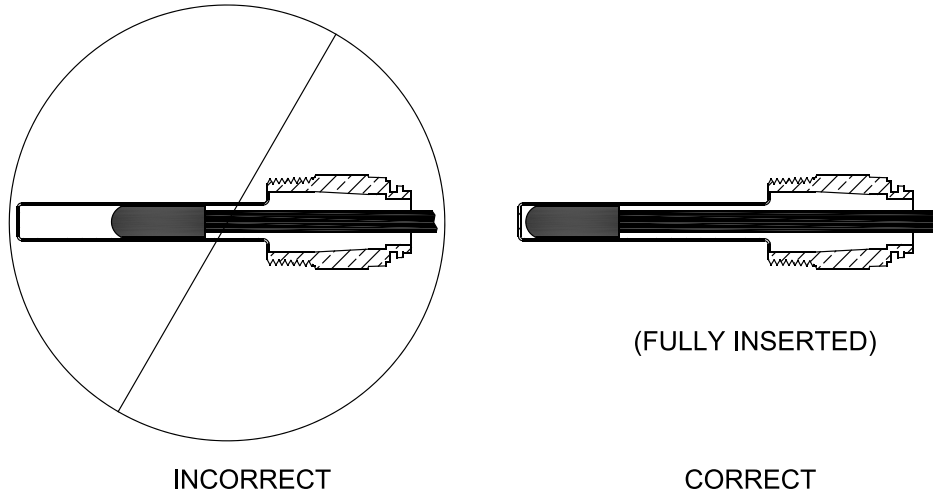

**Figure 3-7: Limit Sensor Insertion**

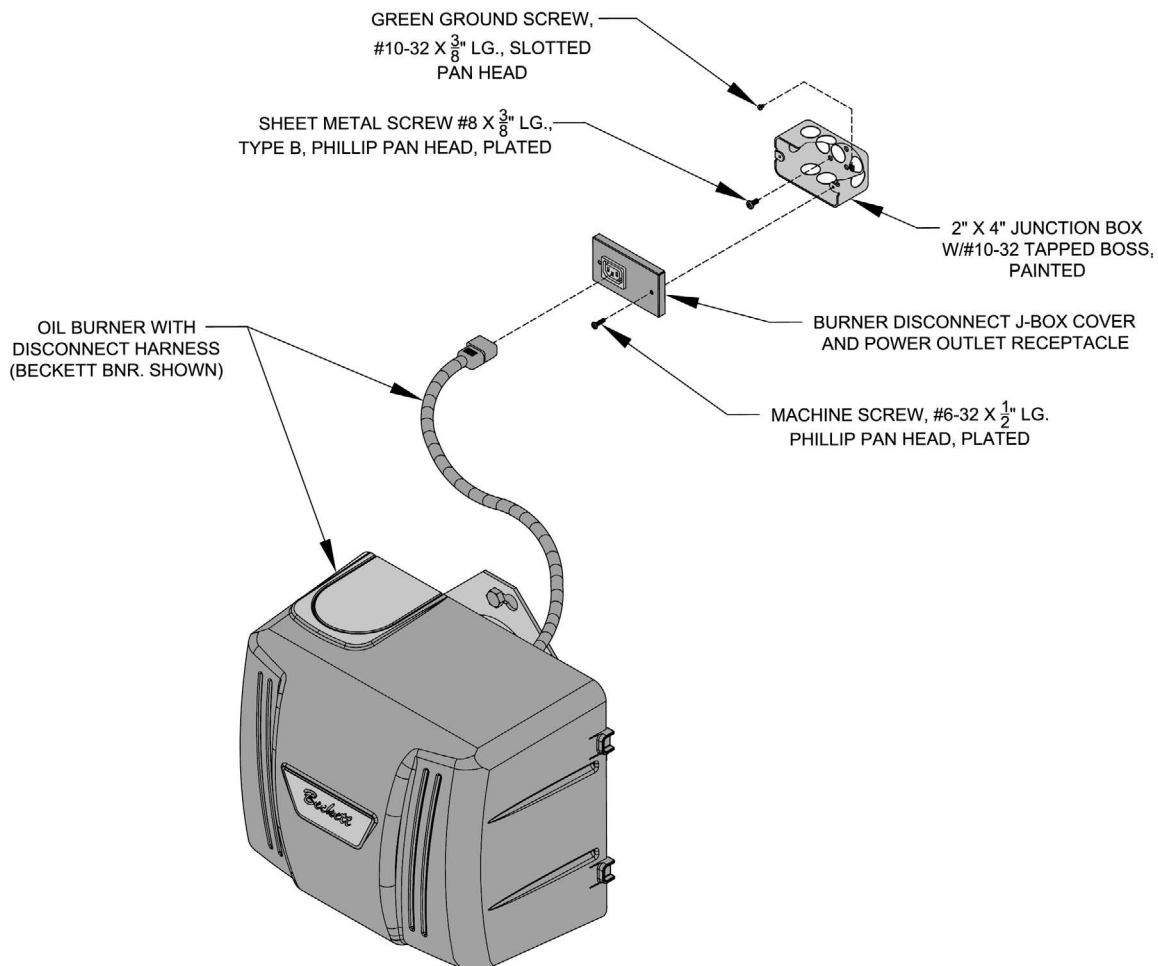

**Figure 3-8: Burner Disconnect Junction Box with Power Outlet Receptacle  
(Mated to Burners with Disconnect Harness)**

## 4 Packaged Boiler Assembly

### A. REMOVE CRATE.

1. Remove all fasteners at crate skid.
2. Lift outside container and remove all other inside protective spacers and bracing. Remove draft regulator box and miscellaneous trim bag containing safety or relief valve, and pipe fittings.

### B. REMOVE BOILER FROM SKID.

1. Boiler is secured to base with 4 bolts, 2 in front and 2 in rear of shipping skid, see Figure 4-4. Remove all bolts.
2. Tilt boiler to right and to rear. Using right rear leg as pivot, rotate boiler 90° in a clockwise direction, and lower left side of boiler to floor. Tilt boiler and remove crate skid. Care should be exercised to prevent damage to jacket or burner.

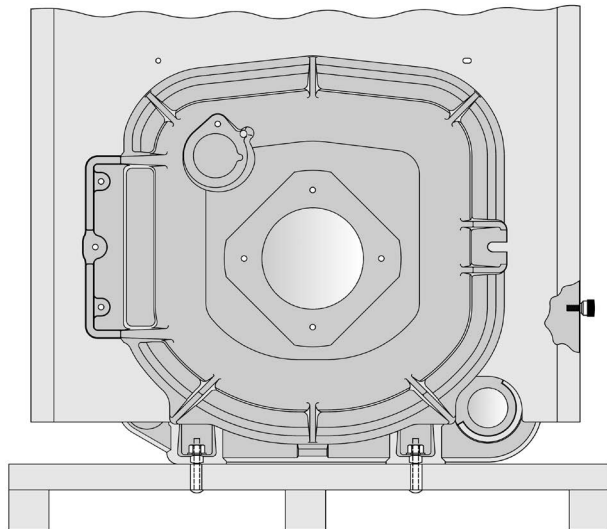

Figure 4-1 : Packaged Boiler Removal from Skid

### ⚠ CAUTION

DO NOT drop boiler. DO NOT bump boiler jacket against floor.

### C. MOVE BOILER TO PERMANENT POSITION by sliding or walking.

### D. PROCEDURE TO OPEN, CLOSE AND SECURE BURNER SWING DOOR with articulated hinge.

Throughout this manual you will be instructed to open and close the burner swing door for various reasons. There is a proper and improper method to closing and securing the burner swing door after it has been removed and re-installed for Field Assembly (Knockdown Boiler) or opened for inspection, cleaning or field service.

1. **TO OPEN BURNER SWING DOOR** (see Figures 4-2 and 4-3).

**Step 1.** Loosen and remove right side latching hardware (5/16 in. flange nut and washer).

**Step 2.** Loosen and remove left side hinge hardware (5/16 in. x 3-1/2 in. lg. hex head flange bolt).

**Step 3.** The duel pivot articulated hinge allows right side of door to be pulled outward and rotated to the left all in one motion. To do so, place your right hand under burner air tube and lift up slightly to help carry the weight of the door and burner. Use your left hand to grasp the door's left side hinge flange, pull outward to rotate the hinge, this motion will move the door outward and to the left approximately 3 in. (see Figure 4-3, Position 2).

**Step 4.** From this position the door can be swung clear of the vertical circulator return piping to provide full access to the combustion chamber and burner head (see Figure 4-3, Position 3).

2. Perform routine inspection, service or cleaning as necessary.
3. To close Burner Swing Door (see Figures 4-2 and 4-3):

**Step 1.** From the fully open position, rotate Burner Swing Door toward the closed position. Make sure that the articulated hinge is rotated to the extreme left position to allow the door to clear the vertical circulator return piping as shown in Figure 4-3, Position 2.

**Step 2.** Grasp the door's left side hinge flange in your left hand and place your right hand under the burner air tube to lift upward. Lift the door up unto the built-in cast ramp/door rest (protruding from the bottom of the front section casting - see Figure 4-2), while rotating the articulated hinge and door to the right and engaging the slot (on right side of door) unto the 5/16 in. stud protruding from the front section.

**Step 3.** Use one hand to help hold door in position by lifting up on rear burner housing or applying pressure directly to the door while re-installing the securing hardware with your opposite hand. **Always install right side latching hardware (5/16 in. flange nut and flat washer) first**, then install left side hinge hardware (**5/16 in. x 3-1/2 in. lg. hex head flange bolt**) second. Apply additional pressure while hand tightening the hardware as far as possible, then release the pressure.

## 4 Packaged Boiler Assembly *(continued)*

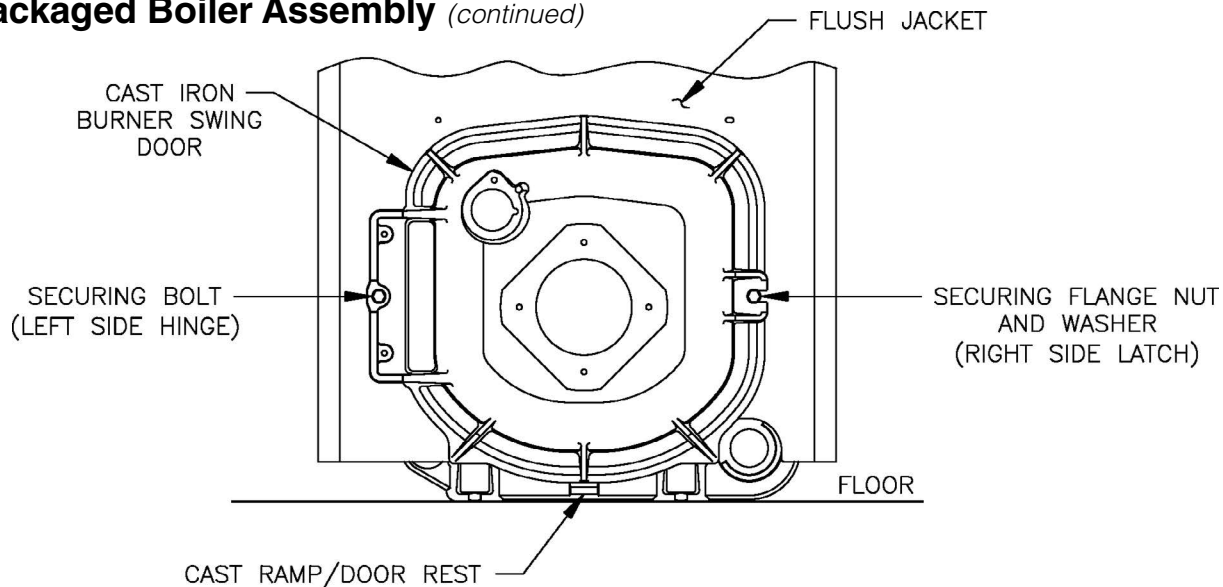

**Figure 4-2: Partial Front View - Burner Swing Door Mounted to Boiler - Fully Closed and Secured**

**NOTICE:** When securing burner swing door make sure door is drawn-in equally on both sides.

**Step 4.** Use a hand wrench to tighten door hardware and **always start with the right side flange nut first.** Use an alternating tightening method from right side flange nut to left side flange bolt to tighten door equally until sealed without applying excessive torque. Never tighten left side flange bolt first or tighten either piece of hardware 100% without using the alternating tightening method described above.

Failure to follow the prescribed procedure could cause thread damage to casting or a leak in the door seal. If left side flange bolt is tightened before right side flange nut, right side of door can not be drawn-in to provide an air tight seal, as shown in Figure 4-4. Applying excessive torque will only cause thread damage.

### **E. INSPECT COMBUSTION CHAMBER TARGET WALL, AND SWING DOOR GASKET.**

1. Open burner swing door using procedure previously outlined in Paragraph D of this section.
2. Using a flashlight, inspect the rear target wall. The target wall should be rigidly secured to the rear boiler section.
3. Inspect ceramic rope located on the swing door. The rope must be evenly distributed around the perimeter of the door groove and cannot bunch or overhang. There must not be a gap where the two ends of the rope meet. Repair or replace if the rope is damaged or if there is a gap between the ends.

### **F. INSTALL COMBUSTION CHAMBER RING/PLATE.**

Refer to Section 3, Paragraph J for installation instructions.

### **G. INSTALL OIL BURNER.** Refer to Section 3, Paragraph L for burner installation instructions.

### **H. INSTALL SAFETY OR RELIEF VALVE IN TAPPING "M",** see Figure 3-3.

Use  $\frac{3}{4}$  in. NPT x 8 in. nipple and/or  $\frac{3}{4}$  in. NPT coupling included in trim bag. Safety or Relief Valve must be installed with spindle in vertical position. Pipe discharge as shown in Figures 5-2 and 5-3. Installation of the safety or relief valve must be consistent with ANSI/ASME Boiler and Pressure Vessel Code, Section IV.

### **⚠ WARNING**

Safety valve discharge piping must be piped near floor to eliminate potential of severe burns. DO NOT pipe in any area where freezing could occur. DO NOT install any shut-off valves, plugs or caps.

### **I. PACKAGED WATER BOILERS WITH CIRCULATORS.**

If your boiler build comes with factory supplied circulator and circulator is to be mounted in return piping connected directly to  $1\frac{1}{2}$  in. boiler return tapping "G", use piping and wiring arrangements outlined in Section 3: Knockdown Boiler Assembly, Paragraph P, Step 2.

# 4 Packaged Boiler Assembly *(continued)*

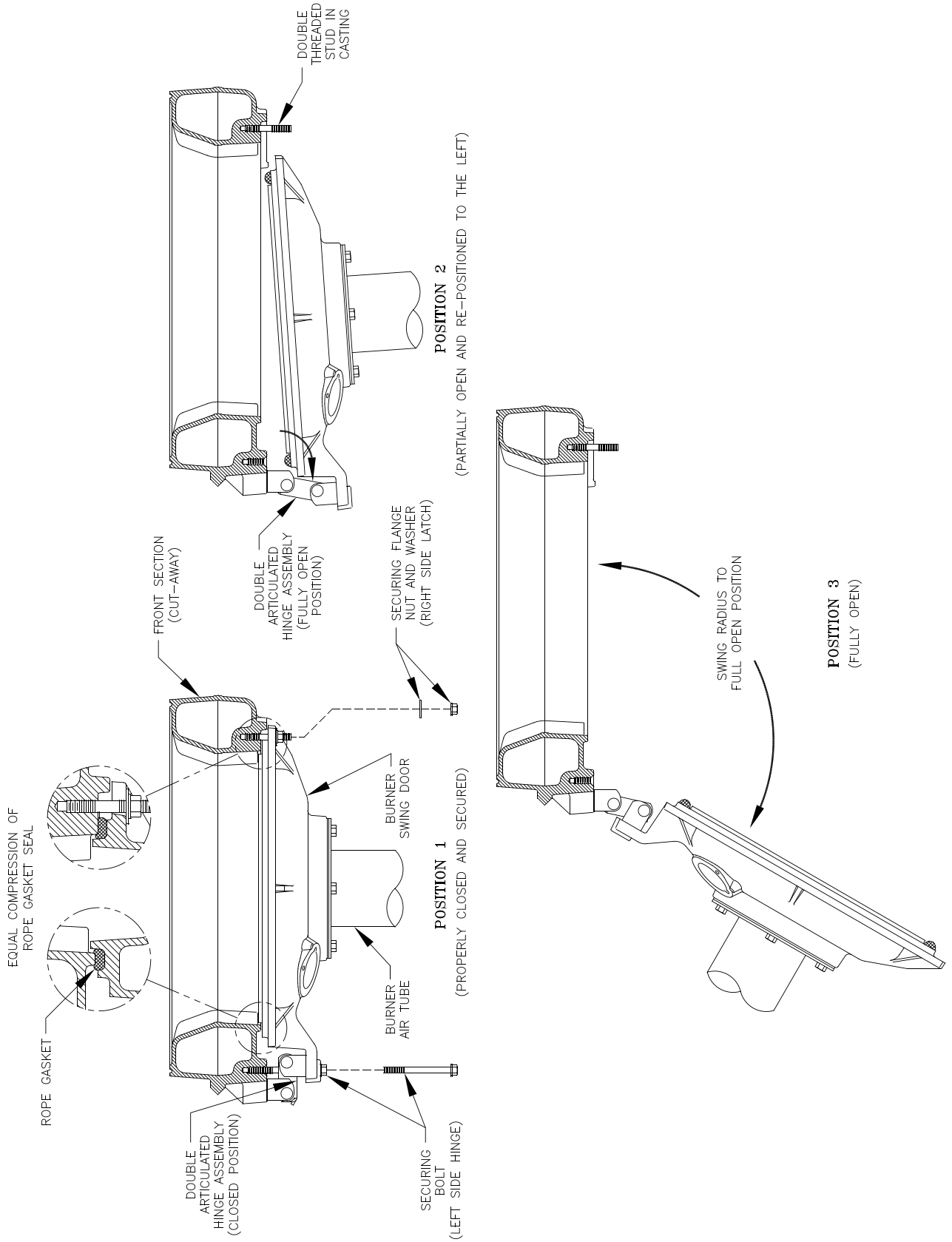
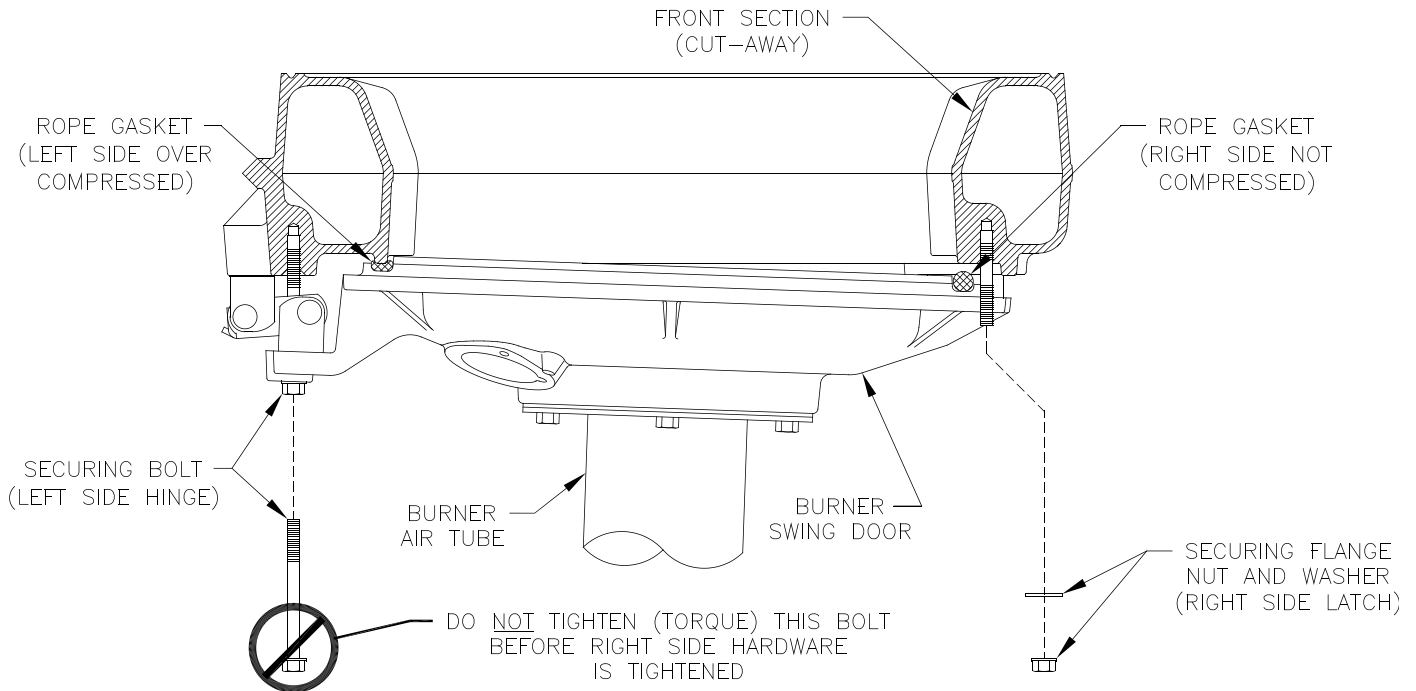

Figure 4-3: Top View - Burner Swing Door Mounted to Cast Iron Block Assembly (Jacket Removed for Clarity)

## 4 Packaged Boiler Assembly *(continued)*



**Figure 4-4: Top View - Burner Swing Door Fully Closed but Not Properly Secured or Sealed**

## 5 Water Boiler Piping and Trim

**NOTICE:** Failure to pipe boiler as specified in this manual may result in excessive system noise, water line fluctuations and water carry over.

### A. EVALUATE THE EXISTING WATER SYSTEM.

Design a piping system and install boiler which will prevent oxygen contamination of boiler water and frequent water additions.

1. There are many possible causes of oxygen contamination such as:
  - a. Addition of excessive make-up water as a result of system leaks.
  - b. Absorption through open tanks and fittings.
  - c. Oxygen permeable materials in the distribution system.
2. In order to insure long product life, oxygen sources must be eliminated. This can be accomplished by taking the following measures:
  - a. Repairing system leaks to eliminate the need for addition of make-up water.
  - b. Eliminating open tanks from the system.
  - c. Eliminating and/or repairing fittings which allow oxygen absorption.
  - d. Use of non-permeable materials in the distribution system.
  - e. Isolating the boiler from the system water by installing a heat exchanger.

#### WARNING

System supply and return piping must be connected to correct boiler pipe.

**U.S. Boiler Company recommends sizing the system circulator to supply sufficient flow (GPM) to allow a 20°F temperature differential in the system. When sizing the system circulator, the pressure drop of all radiators, baseboard and radiant tubing and all connecting piping must be considered.**

#### CAUTION

Maintain minimum ½ inch clearance from hot water piping to combustible materials.

- ### B. CONNECT SYSTEM SUPPLY AND RETURN PIPING TO BOILER.
- See Figures 5-2 and 5-3. Also, consult Residential Hydronic Heating Installation and Design I=B=R Guide.

1. If this boiler is used in connection with refrigeration systems, the boiler must be installed so that the chilled medium is piped in parallel with the heating boiler using appropriate valves to prevent the chilled medium from entering the boiler. See Figure 5-1. Also, consult Residential Hydronic Heating Installation and Design I=B=R Guide.
2. If this boiler is connected to heating coils located in air handling units where they may be exposed to refrigerated air, the boiler piping must be equipped with flow control valves to prevent gravity circulation of boiler water during the operation of the cooling system.
3. If boiler is used with an Indirect Domestic Water Heater, install the Indirect Water Heater as a separate heating zone. Refer to the Indirect Water Heater Installation, Operating, and Service Instructions for additional information.
4. Use a boiler bypass if the boiler is to be operated in a system which has a large volume or excessive radiation where low boiler water temperatures may be encountered (i.e. converted gravity circulation system, etc.) The bypass should be the same size as the supply and return lines with valves located in the bypass and return line as illustrated in Figures 5-2 and 5-3 in order to regulate water flow for maintenance of higher boiler water temperature.

#### WARNING

The use of a low water cut-off device, while not required unless radiation level is below the boiler, is highly recommended.

5. If a Low Water Cut-Off (LWCO) is required, it must be mounted in the system piping above the boiler. The minimum safe water level of a hot water boiler is just above the highest water containing cavity of the boiler; that is, a hot water boiler must be full of water to operate safely. Refer to Appendix at the rear of this manual.
6. **If it is required to perform a long term pressure test of the hydronic system,** the boiler should first be isolated to avoid a pressure loss due to the escape of air trapped must first be removed from the boiler.

## 5 Water Boiler Piping and Trim *(continued)*

To perform a long term pressure test including the boiler, ALL trapped air must first be removed from the boiler.

A loss of pressure during such a test, with no visible water leakage, is an indication that the boiler contained trapped air.

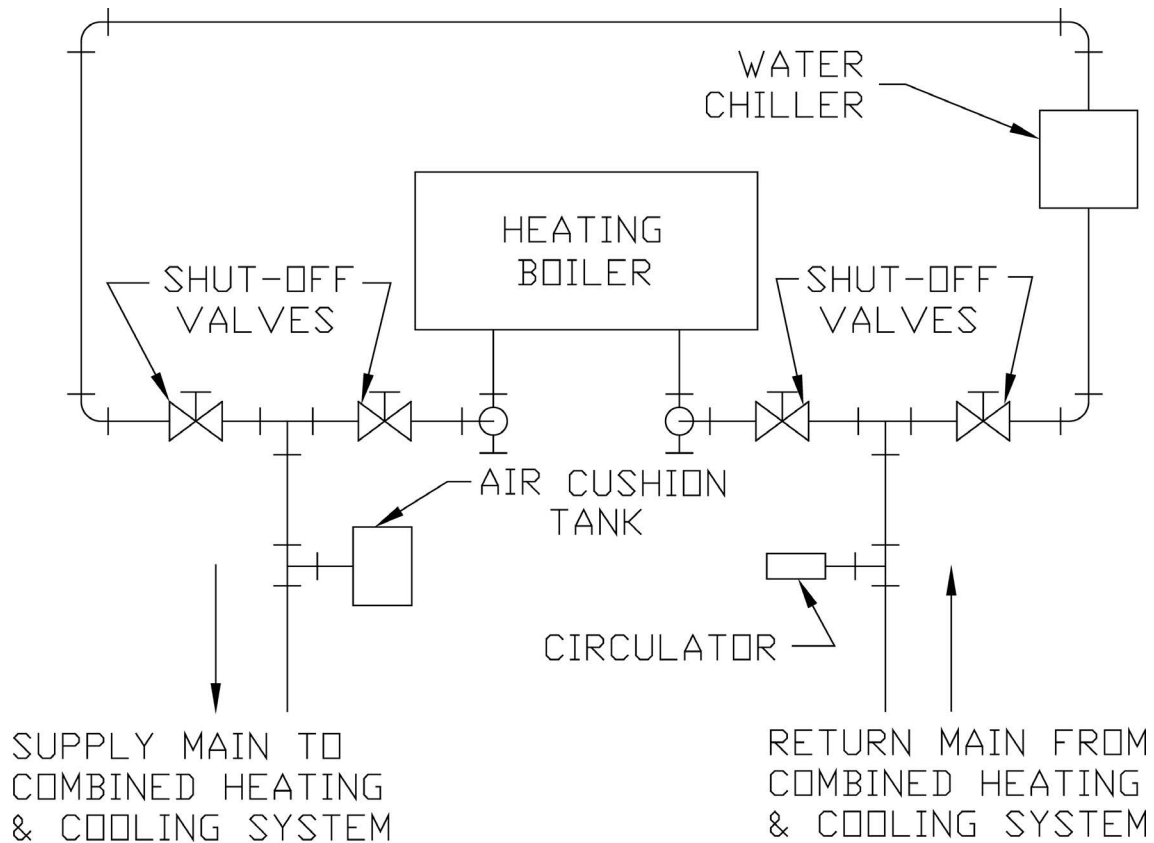

**Figure 5-1: Recommended Piping for Combination Heating and Cooling (Refrigeration) System**

# 5 Water Boiler Piping and Trim (continued)

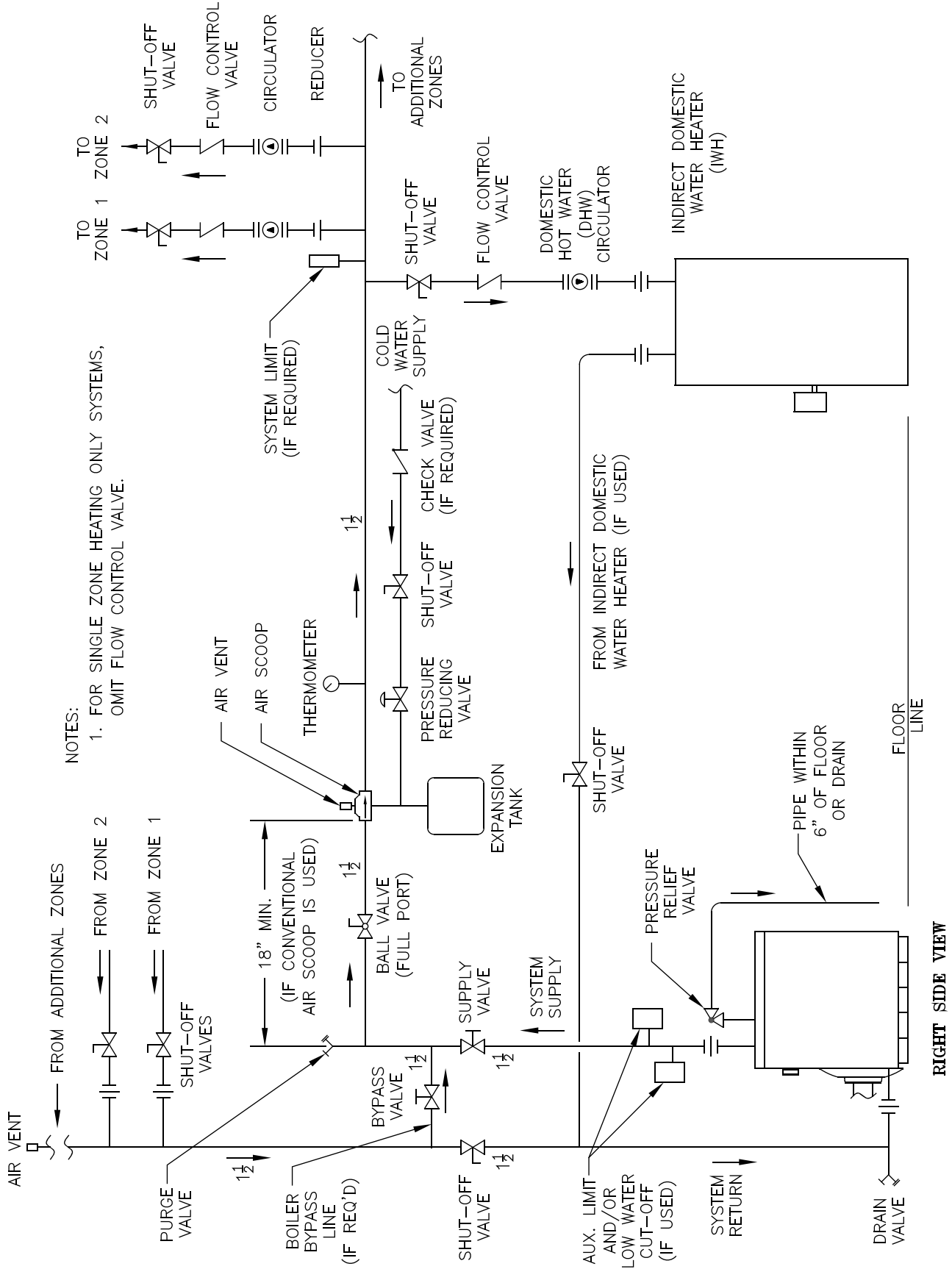

NOTES:  
 1. FOR SINGLE ZONE HEATING ONLY SYSTEMS,  
 OMIT FLOW CONTROL VALVE.

Figure 5-2: Recommended Water Piping for Circulator Zoned Heating System - Supply Side Circulators

# 5 Water Boiler Piping and Trim (continued)

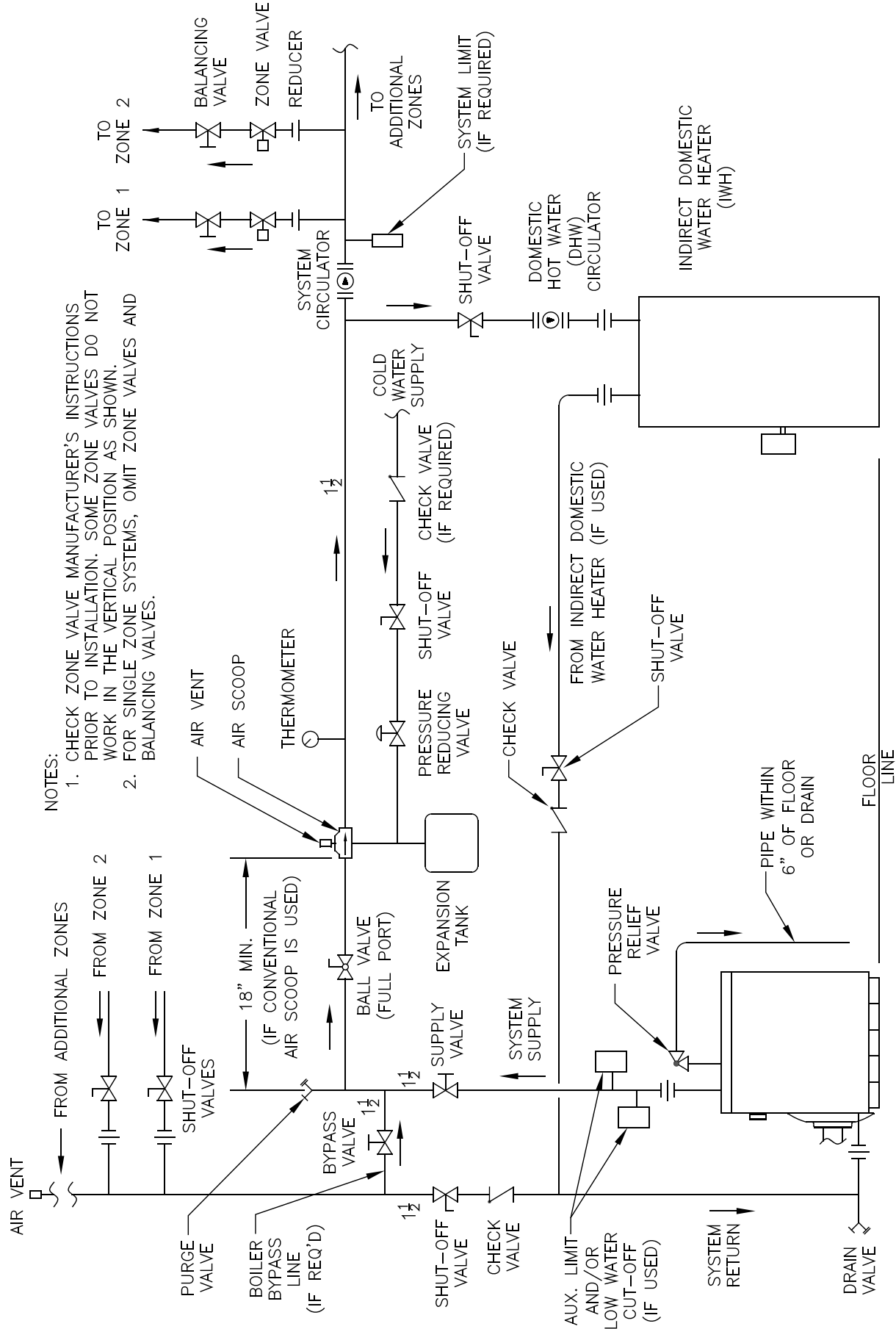

- NOTES:
1. CHECK ZONE VALVE MANUFACTURER'S INSTRUCTIONS PRIOR TO INSTALLATION. SOME ZONE VALVES DO NOT WORK IN THE VERTICAL POSITION AS SHOWN.
  2. FOR SINGLE ZONE SYSTEMS, OMIT ZONE VALVES AND BALANCING VALVES.

RIGHT SIDE VIEW

Figure 5-3: Recommended Water Piping for Zone Valve Zoned Heating System - Supply Side Circulator

## 6 Tankless and Indirect Water Heater Piping

- A. CONNECT TANKLESS HEATER PIPING** as shown in Figure 6-1. See Table 6-2 for Tankless Heater Rating.

### WARNING

Install automatic mixing valve at tankless heater outlet to avoid risk of burns or scalding due to excessively hot water at fixtures. Adjust and maintain the mixing valve in accordance with the manufacturer's instructions. **DO NOT** operate tankless heater without mixing valve.

THE FOLLOWING GUIDELINES SHOULD BE FOLLOWED WHEN PIPING THE TANKLESS HEATER:

1. **FLOW REGULATION** — If flow through the heater is greater than its rating, the supply of adequate hot water may not be able to keep up with the demand. For this reason a flow regulator matching the heater rating should be installed in the cold water line to the heater. The flow regulator should preferably be located below the inlet to the heater and a minimum of 3 ft. away from the inlet so that the regulator is not subjected to excess temperatures that may occur during "off" periods when it is possible for heat to be conducted back through the supply line. The flow regulator also limits the flow of supply water regardless of inlet pressure variations in the range of 20 to 125 psi.
2. **TEMPERING OF HOT WATER** — Installation of an automatic mixing valve will lengthen the delivery of the available hot water by mixing some cold water with the hot. This prevents the possibility of scalding hot water at the fixtures. In addition, savings of hot water will be achieved since the user will not waste as much hot water while seeking a water temperature. Higher temperature hot water required by dishwashers and automatic washers is possible by piping the hot water from the heater prior to entering the mixing valve. The mixing valve should be "trapped" by installing it below the cold water inlet to heater to prevent lime formation in the valve. Refer to Figure 6-1.
3. **FLUSHING OF HEATER** — All water contains

### CAUTION

Use of hard water with a tankless coil will, over a short period of time, reduce the output of the coil, reduce flow due to increased pressure drop and reduce the useful life of the coil.

some sediment which settles on the inside of the coil. Consequently, the heater should be periodically back washed. This is accomplished by installing hose bibs as illustrated and allowing water at city pressure to run into hose bib A, through the heater, and out hose bib B until the discharge is clear. The tees in which the hose bibs are located should be the same size as heater connections to minimize pressure drop.

4. **HARD WATER** — A water analysis is necessary to determine the hardness of your potable water. This is applicable to some city water and particularly to well water. An appropriate water softener should be installed based on the analysis and dealer's recommendation. This is not only beneficial to the tankless heater but to piping and fixtures plus the many other benefits derived from soft water.

**Use street elbow fittings in tankless in and out connections to assure adequate clearance of piping.**

## 6 Tankless and Indirect Water Heater Piping *(continued)*

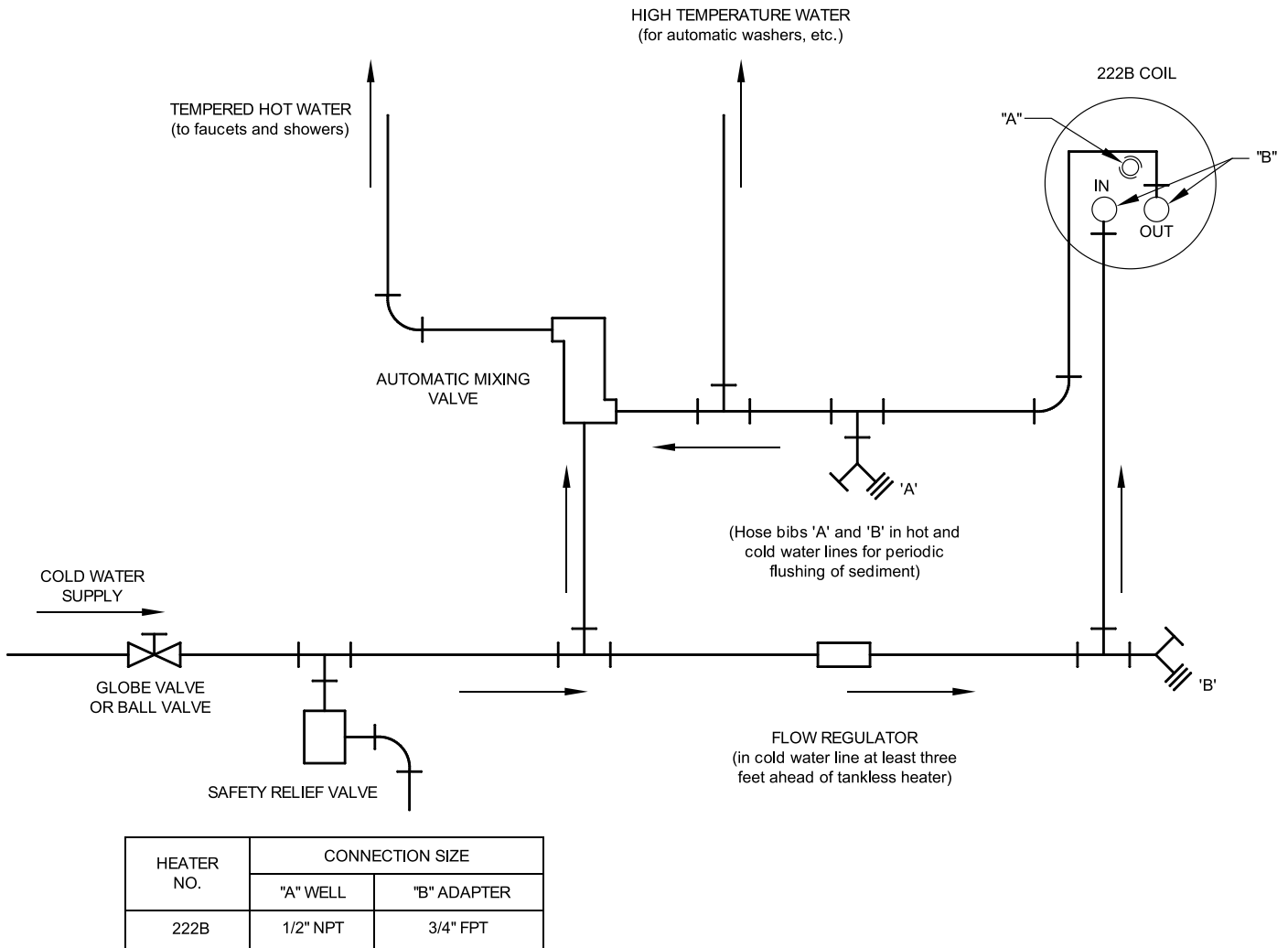

**Figure 6-1: Schematic Tankless Heater Piping**

**Table 6-2: Tankless Heater Data:  
Front Mounted Heater on Water Boilers**

Boiler Series	Heater No.	Heater Rating (GPM)	Pressure Drop thru Heater (PSI)
V8H3	222B	3.00	18.7
V8H4	222B	3.25	25.2
V8H5	222B	3.75	31.6
V8H6	222B	4.00	37.0
V8H7	222B	4.25	41.3

## 7 Venting and Air Intake Piping

### WARNING

Vent this boiler according to these instructions. Failure to do so may cause products of combustion to enter the home resulting in severe property damage, personal injury or death.

- Insufficient Combustion Air Supply may result in the production and release of deadly carbon monoxide (CO) into the home which can cause severe personal injury or death.
- Improper venting may result in property damage and the release of flue gases which contain deadly carbon monoxide (CO) into the home, which can cause severe personal injury, death, or substantial property damage.
- Inspect existing chimney and vent connector for obstructions and deterioration before installing boiler. Failure to clean or replace perforated pipe or chimney liner will cause severe injury or death.
- Do not de-rate the appliance. Failure to fire the boiler at it's designed input may cause excessive condensation upon the interior walls of the chimney. In addition, the lower input may not create enough draft to adequately evacuate the by-products of combustion.

#### A. GENERAL VENTING GUIDELINES

1. Chimney venting is an important part of a safe and efficient oil fired appliance system. Contact your local fire and building officials on specific requirements for restrictions and the installation of fuel oil burning equipment. In addition, consult with a professional knowledgeable on the requirements of NFPA 31 – Standard for the Installation of Oil-Burning Equipment and NFPA 211 - Standard for Chimneys, Fireplaces, Vents, and Solid Fuel-Burning Appliances for installations in the United States.
2. The safe venting of oil fired boilers is dependant on many factors. Some of these factors include:
  - a. sufficient draft during the entire heating season to allow for the safe discharge of combustion by-products and;
  - b. suitable corrosion protection in the event of condensing flue gases. Only a trained and qualified contractor may install this product.
3. The V8H shall be vented into any of the following:
  - a. Masonry or metal chimney. Build and install in accordance with local buildings codes; or local authority having jurisdiction; or “Standards for Chimney, Fireplace, Vents, and Solid Fuel Burning Appliances”, ANSI/ NFPA 211 and/or National Building Code of Canada. Masonry chimney must be lined with listed chimney system. Listed clay flue lined masonry chimneys meet venting requirements.
    - External chimneys are more susceptible to flue gas condensation due to colder outside air temperatures. To prevent corrosion due to flue gas condensation, use a listed corrosion-resistant metal liner in chimney.
  - Oversized chimneys are more susceptible to flue gas condensation. To reduce the likelihood of flue gas condensation and ensure proper draft, use a properly sized listed metal liner in oversized chimney.
4. Chimney Inspection – Prior to the installation of any new or replacement fuel burning equipment the chimney shall be inspected by a qualified installer. The chimney shall be inspected for integrity as well as for proper draft and condensate control. Some jurisdictions require the use of a liner when changing fuel types. Some jurisdictions require the use of a liner even when the same fuel is used. At a minimum, the chimney shall be examined by a qualified person in accordance with the requirements of Chapter 11 of NFPA 211, Standard for Chimneys, Fireplaces, Vents, and Solid Fuel-Burning Appliances.
  - a. Loose Mortar – Loose mortar could be an indication of a prior history of condensing flue gases upon the inside walls of the chimney. Colder climates are more susceptible to this condition. Under no circumstances shall a chimney of this condition be used until it meets the requirements of NFPA 211 or CSA B139.
  - b. Unlined Chimney – Under no circumstances shall a chimney constructed of brick only be used. Only approved clay liners or listed chimney lining systems shall be used as specified in NFPA 31.
  - c. Abandoned Openings – Openings through the chimney wall that are no longer used shall be sealed in accordance to NFPA 211. Often abandoned openings are improperly sealed and usually covered by a gypsum wall covering.
  - d. Clean Chimney – Chimney shall be free of all loose debris.

# 7 Venting and Air Intake Piping (continued)

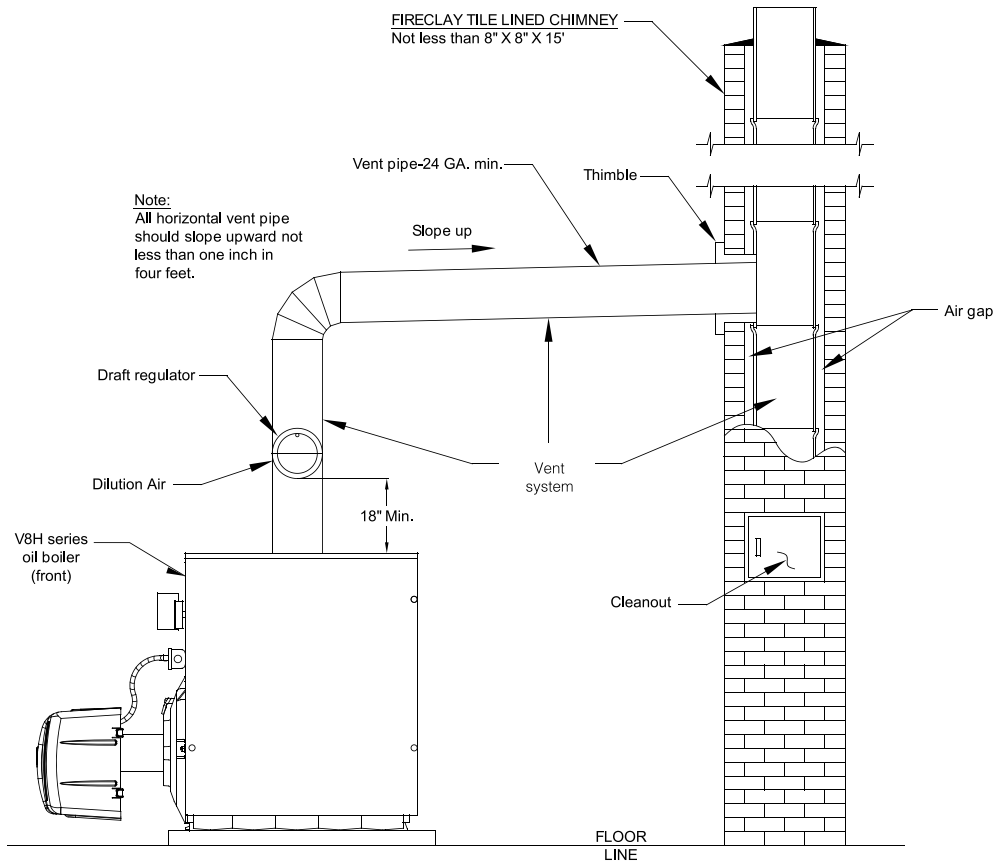

Figure 7-1: Recommended Vent Pipe Arrangement and Chimney Requirements

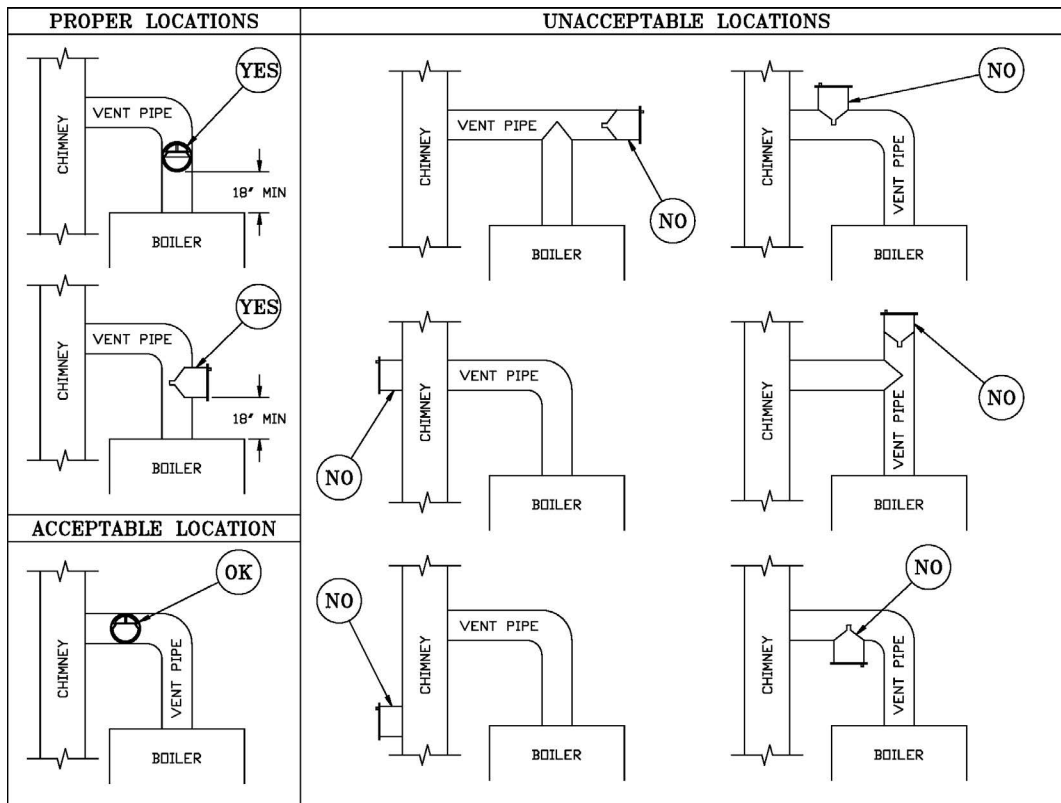

Figure 7-2: Proper and Improper Locations of Draft Regulator

## 7 Venting and Air Intake Piping *(continued)*

5. Draft Regulator – the draft regulator supplied with the boiler (or equivalent) must be used with this appliance. Refer to Figures 7-1 and 7-2.

### CHIMNEY CONNECTOR

1. A chimney connector (vent pipe) is used to connect the boiler to the base of the chimney. The chimney connector should be kept as short as possible. The horizontal length of the chimney connector shall not be greater than 10 feet.

#### **⚠ DANGER**

The chimney and connector shall be inspected annually for signs of debris and corrosion. Loose mortar at the base of the chimney may be a sign of condensate damage to the chimney. A chimney professional shall be contacted immediately to examine the damage and recommend a solution. Long term operation while in this condition may cause a venting failure and force flue gases into the living space. If the chimney is to be re-lined use the recommendations in NFPA 31, Appendix E.

2. Vent Connector shall be any of the following and of the same size as the outlet of boiler.
  - a. Type L or a factory built chimney material that complies with the Type HT requirements of ANSI/UL 103. Install in accordance with listing and manufacturer's instructions.

- b. Steel pipe having resistance to corrosion and heat with a minimum wall thickness of 24 Gauge (0.024 in.).

#### **⚠ DANGER**

Any sign of condensate seepage at the base of the chimney shall be inspected immediately. The discoloration may be a sign of chimney damage and must be remedied immediately.

### DRAFT

1. The natural draft generated through a chimney is dependent on several factors including, chimney height, temperature of flue gases, cross section area of chimney, chimney wall insulation value, dilution air and total volume of flue gases, to name a few. Make sure that the boiler has been running for at least 5 minutes before measuring the draft.
2. Minimum Draft Overfire – The draft induced by a chimney must create at least a pressure of -0.02 inches water column (" w.c.). The pressure at the canopy **cannot** be positive since this could create a condition that allows flue gas by-products to escape from the draft regulator. A negative pressure reading up to -0.03 inches water column is acceptable for proper operation.

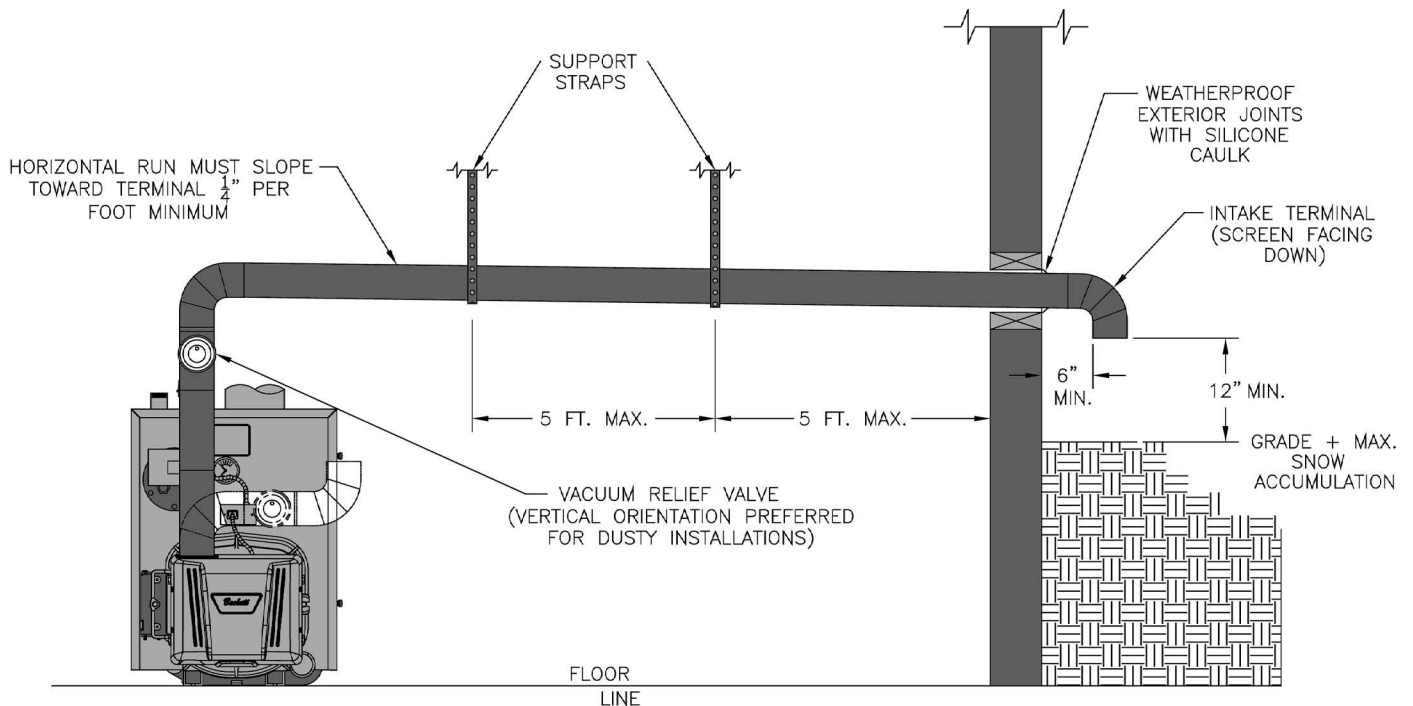

FRONT VIEW

Figure 7-3: Optional Air Intake Piping Installation - Only Available with Beckett Burner

## 7 Venting and Air Intake Piping *(continued)*

### STACK TEMPERATURE

1. The temperature of the flue gases has a significant effect on the amount of draft created in a vertical chimney as well as the propensity to create condensate. The higher the stack temperature, the greater the amount of draft that can be generated. A lower stack temperature not only reduces the amount of draft that can be created but it also increases the possibility that the flue gases could condense in the chimney connector or stack.
2. NFPA 31 has information to help the installer make an appropriate choice of venting materials. In some cases a chimney may have to be lined to create sufficient draft. In other cases, the chimney may have to be lined to prevent the corrosion of a masonry chimney. Consult with a chimney specialist knowledgeable on the requirements for chimney requirements in your area.

### CAUTION

Any doubt on the condition of a chimney or its ability to prevent the generation and accumulation of flue gas condensate, must be relined according to NFPA 31 (United States). Use the chimney venting tables as a guide. It is highly recommended that any borderline application should result in the relining of the chimney with a suitable liner that creates sufficient draft and to protect against corrosion caused by flue gas condensate.

### **B. OPTIONAL AIR INTAKE PIPING**

**INSTALLATION** - Outdoor air for combustion may be provided with an optional U.S. Boiler Company V8H™ Fresh Air Accessory Kit (**ONLY AVAILABLE ON BECKETT BURNERS**, with plastic cover application, P/N 102119-01), refer to Figure 7-3. Refer to Fresh Air Accessory Kit Instructions for installation and air intake piping details.

## 8 Electrical

### DANGER

Positively assure all electrical connections are unpowered before attempting installation or service of electrical components or connections of the boiler or building. Lock out all electrical boxes with padlock once power is turned off.

### WARNING

Failure to properly wire electrical connections to the boiler may result in serious physical harm.

- Electrical power may be from more than one source. Make sure all power is off before attempting any electrical work.
- Each boiler must be protected with a properly sized fused disconnect.
- Never jump out or make inoperative any safety or operating controls.
- The primary control may be damaged or may not function properly if 120 volt power supply is NOT wired into control as follows:

The 120V interrupted hot (black) wire must be connected to the primary control black wire, the 120V neutral (white) wire must be connected to the primary control white wire and the 120V constant hot (red) wire must be connected to the primary control red wire.

#### A. GENERAL

1. Install wiring and electrically ground boiler in accordance with requirements of the authority having jurisdiction, or in absence of such requirements the National Electrical Code, ANSI/NFPA 70.
2. Refer to National Electric Code or Local Electric Codes for proper size and type of wire required. Follow Code.

3. A separate electrical circuit must be run from the main electrical service with an over-current device/disconnect in the circuit. A service switch is recommended and may be required by some local jurisdictions.
4. Use anti-short bushings on all wiring passing through boiler jacket, junction boxes and/or control boxes.
5. Use armored cable (BX) over all exposed line voltage wiring.
6. If an indirect domestic water heater is used, use priority zoning. **DO NOT** use priority zoning for Hydro-Air Systems.
7. Wiring should conform to Figures 8-1 through 8-4.

- B. INSTALL A ROOM THERMOSTAT** on an inside wall about four feet above floor. Never install thermostat on an outside wall or where it will be influenced by drafts, hot or cold water pipes, lighting fixtures, television, rays of the sun or near a fireplace. Keep large furniture away from thermostat so there will be free movement of room air around this control.

Heat Anticipator in Thermostat should be set to match the requirements of the control to which it is connected. See Figures 8-1 thru 8-4 for desired system and heat anticipator setting. If system tends to overheat above the thermostat's temperature setting, reduce heat anticipator settings by .1 or .2 amps. If system tends to short cycle without reaching desired room temperature, increase heat anticipator setting by .1 or .2 amps.

# 8 Electrical (continued)

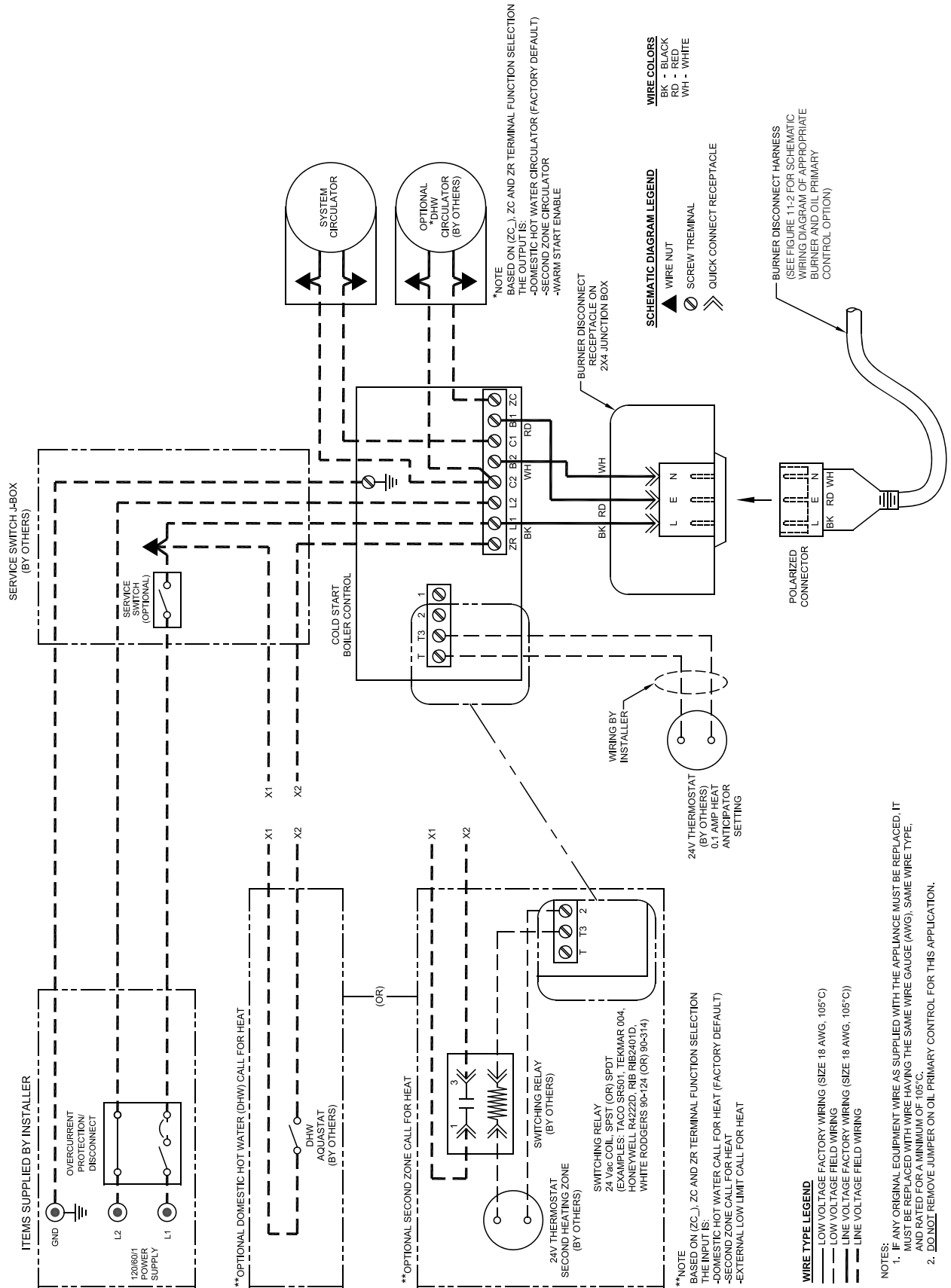
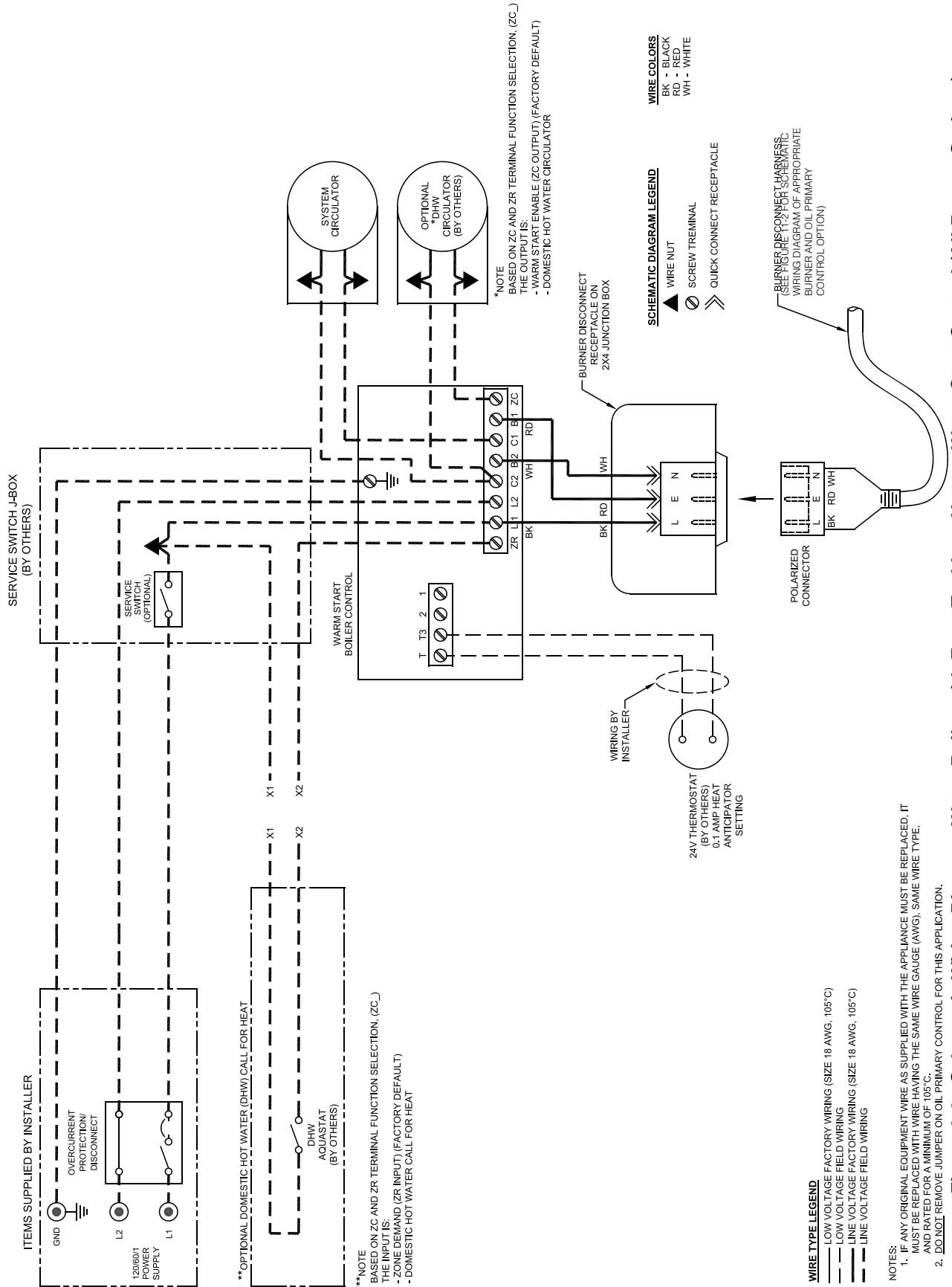

Figure 8-1: Schematic Wiring Diagram, Water Boiler without Tankless Heater, Cold Start Control (All Burner Options)

# 8 Electrical (continued)



**Figure 8-2: Schematic Wiring Diagram, Water Boiler with Front Tankless Heater, Warm Start Control (All Burner Options)**

**NOTES:**

- IF ANY ORIGINAL EQUIPMENT WIRE AS SUPPLIED WITH THE APPLIANCE MUST BE REPLACED, IT MUST BE REPLACED WITH WIRE HAVING THE SAME WIRE GAUGE (AWG), SAME WIRE TYPE, AND RATED FOR A MINIMUM OF 105°C.
- DO NOT REMOVE JUMPER ON OIL PRIMARY CONTROL FOR THIS APPLICATION.

# 8 Electrical *(continued)*

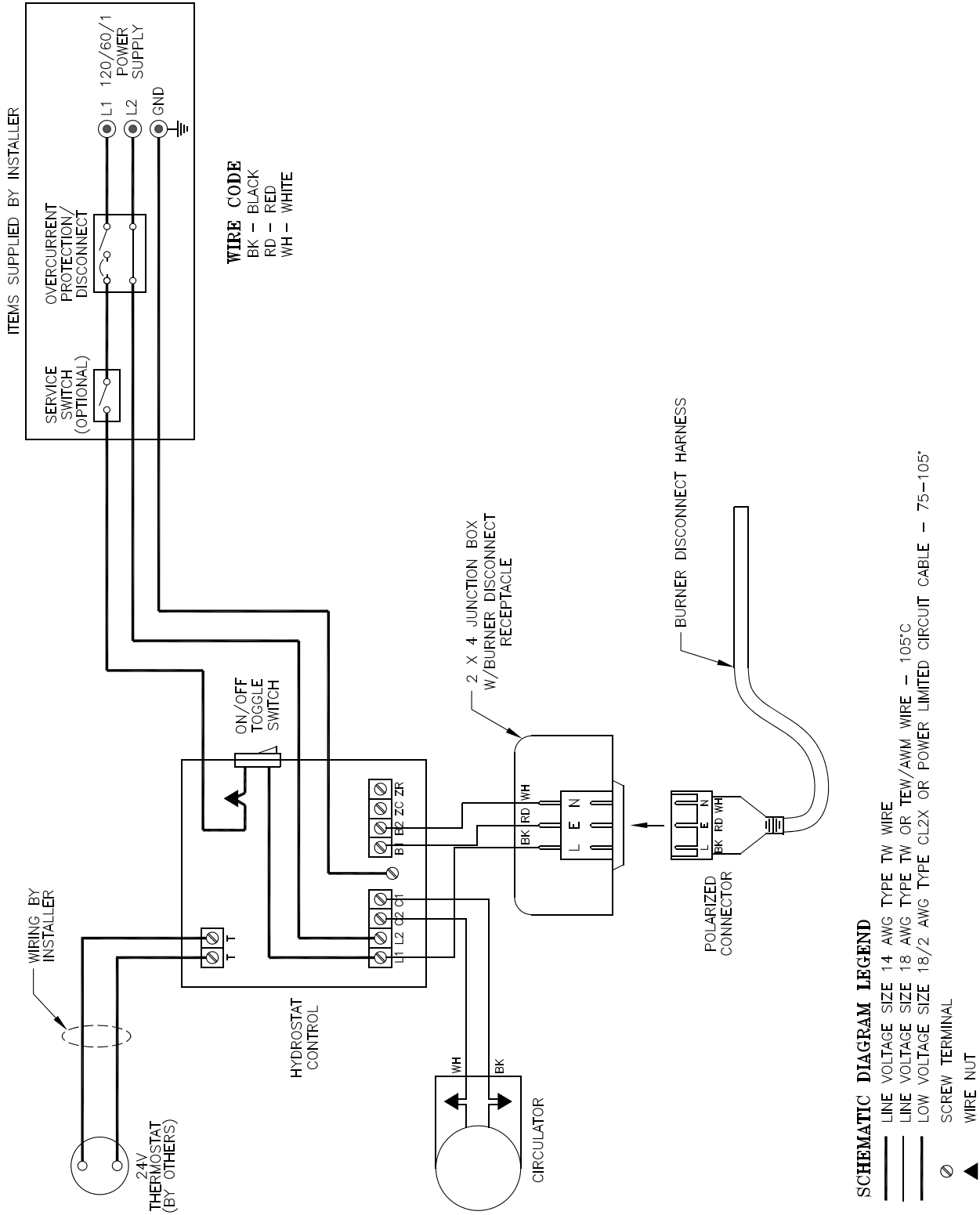

Figure 8-3: Schematic Wiring Diagram, Water Boiler, Hydrolevel Hydrosstat (All Burners)

# 8 Electrical (continued)

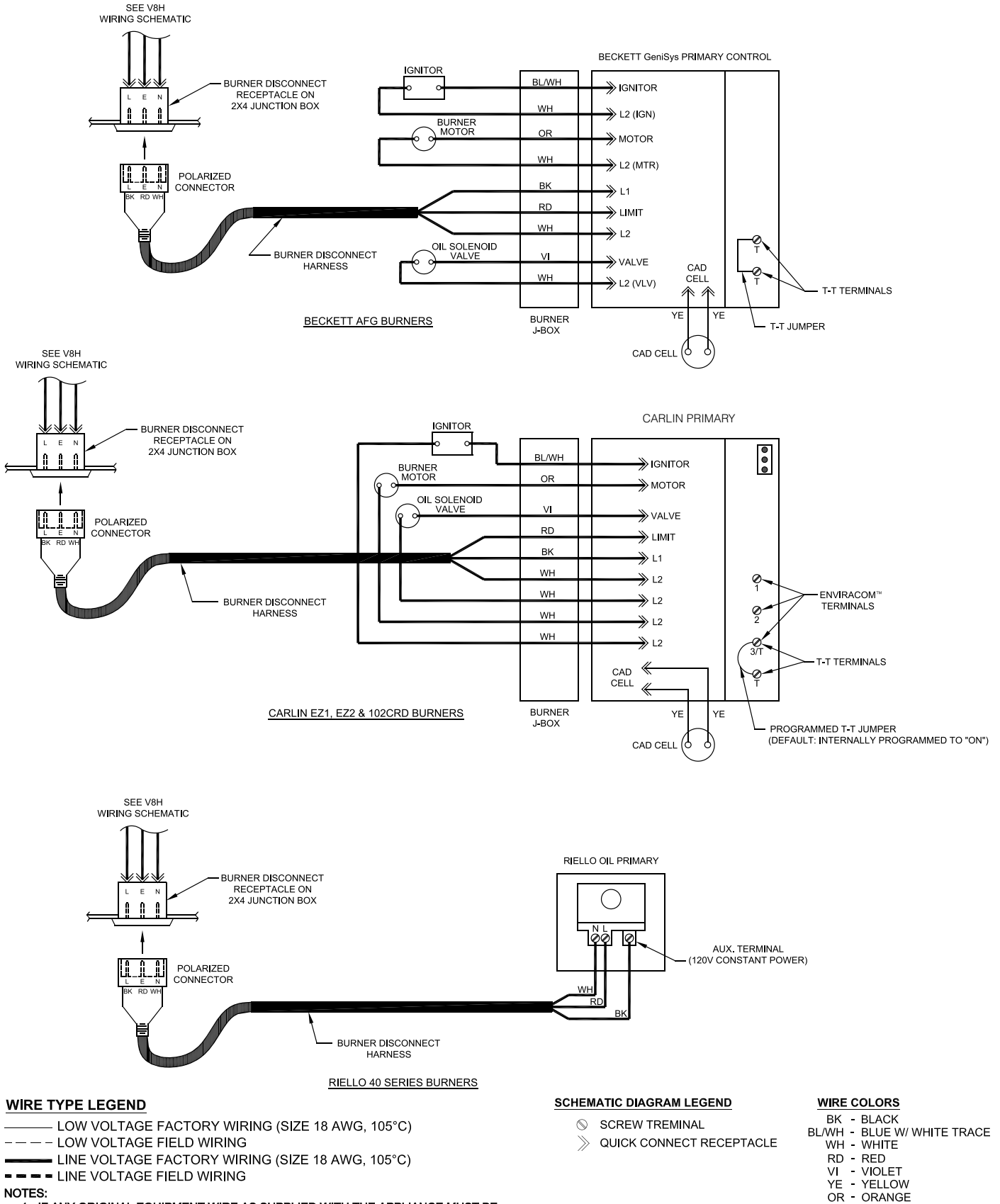

Figure 8-4: Schematic Wiring Diagrams For All Burner Options w/Variou Oil Primary Controls

## 9 Oil Piping

**NOTICE:** The National Oilheat Research Alliance (NORA) recommends single pipe oil systems and high-quality filtration for all fuel types. This should include at least a 10-micron Spin-on filter. Double filtration provides even greater assurance clean fuel will get to the pump. Contaminants in the tank that enter the fuel supply to the burner can cause pump sticking/seizing. These contaminants may increase in the early stages of transitioning to modern fuels (Ultra Low Sulfur and Bio Blends). High quality filtration adds protection against pump sticking.

### A. GENERAL

1. Use flexible oil line(s) so the burner swing door can be opened without disconnecting the oil supply piping.
2. A supply line fuel oil filter is recommended as a minimum for all firing rates but a pleated paper fuel oil filter is recommended for the firing rates below 1.0 GPH to prevent nozzle fouling.
3. Use Flared fittings only. Cast iron fittings cannot be used.

**NOTICE: DO NOT** use compression fittings.

Oil piping must be absolutely airtight or leaks or loss of prime may result. Bleed line and fuel unit completely.

Refer to your local jurisdictions regarding any special considerations for fuel supply requirements. In addition, refer to NFPA 31, Standard for the Installation of Oil-Burning Equipment for Installations in the United States and CSA B139-04 for Installation in Canada.

4. Use of a high efficiency micron filter (Garber or equivalent) in addition to a conventional filter is highly recommended.
5. Piping used to connect the oil burner to the oil supply tank shall not be smaller than 3/8 in. iron pipe or 3/8 in. OD copper tubing. Copper tubing shall have a .032 in. minimum wall thickness.

### ⚠ WARNING

Under no circumstances can copper with sweat style connectors be used.

**NOTICE:** Some jurisdictions require the use of a fusible shutoff valve at the tank and/or the burner. In addition, some jurisdictions require the use of a fusible electrical interlock with the burner circuit. Check your local Codes for special requirements.

### B. SINGLE PIPE OIL LINES

1. Standard burners are provided with single-stage 3450 RPM fuel units with the bypass plug removed for single-pipe installations.
2. The single-stage fuel unit may be installed single-pipe with gravity feed or lift. Maximum allowable lift is 8 feet. See Figure 9-1.
3. Fuel Oil Line Deaerator – On many occasions a leaky oil delivery line can introduce air into the fuel oil supply system. This often creates a rough starting condition and can create a burner lockout state. In addition to fixing the leak, a fuel line deaerator can be installed to eliminate air. The single line from the fuel tank is connected to the deaerator. The burner pump must be connected to the deaerator as a two pipe system. Follow the oil pump manufacturer's recommendations for conversion to a two pipe system.

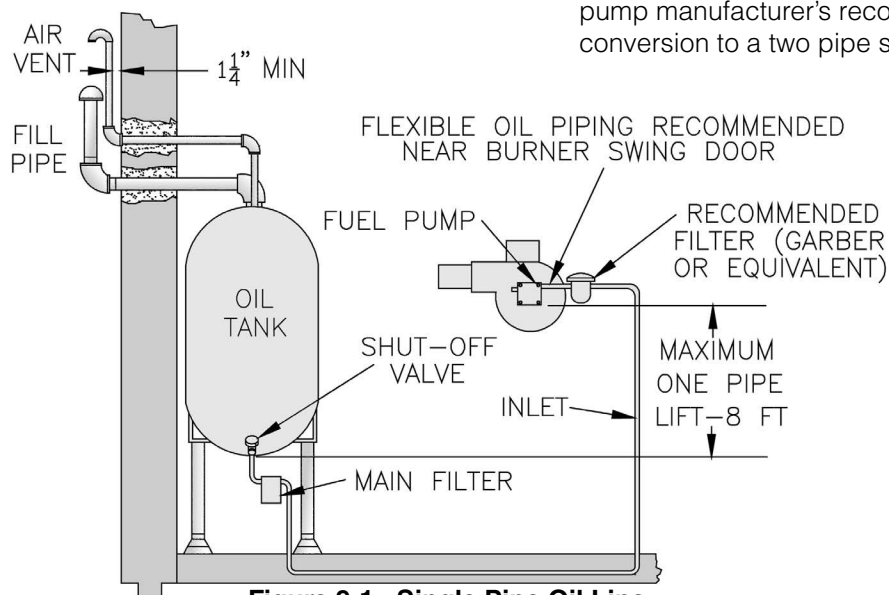

Figure 9-1: Single Pipe Oil Line

# 9 Oil Piping *(continued)*

## C. TWO PIPE OIL LINES

1. For two piped systems, where more lift is required, the two-stage fuel unit is recommended.

Table 9-2 (two-stage) and Table 9-3 (single-stage) show allowable lift and lengths of 3/8 inch and 1/2 inch OD tubing for both suction and return lines. Refer to Figure 9-4.

**Table 9-2: Two-Stage Units (3450 RPM) - Two Pipe Systems**

Lift "H" (See Figure 11-2)	Maximum Length of Tubing "H" + "R" (See Figure 13-1)	
	3/8 in. OD Tubing (3 GPH)	1/2 in. OD Tubing (3 GPH)
0'	93'	100'
2'	85'	100'
4'	77'	100'
6'	69'	100'
8'	60'	100'
10'	52'	100'
12'	44'	100'
14'	36'	100'
16'	27'	100'
18'	---	76'

**Table 9-3: Single-Stage Units (3450 RPM) - Two Pipe Systems**

Lift "H" (See Figure 11-2)	Maximum Length of Tubing "H" + "R" (See Figure 13-1)	
	3/8 in. OD Tubing (3 GPH)	1/2 in. OD Tubing (3 GPH)
0'	84'	100'
1'	78'	100'
2'	73'	100'
3'	68'	100'
4'	63'	100'
5'	57'	100'
6'	52'	100'
7'	47'	100'
8'	42'	100'
9'	36'	100'
10'	31'	100'
11'	26'	100'
12'	21'	83'
13'	---	62'
14'	---	41'

OUTSIDE TANK FUEL PUMP ABOVE BOTTOM OF TANK

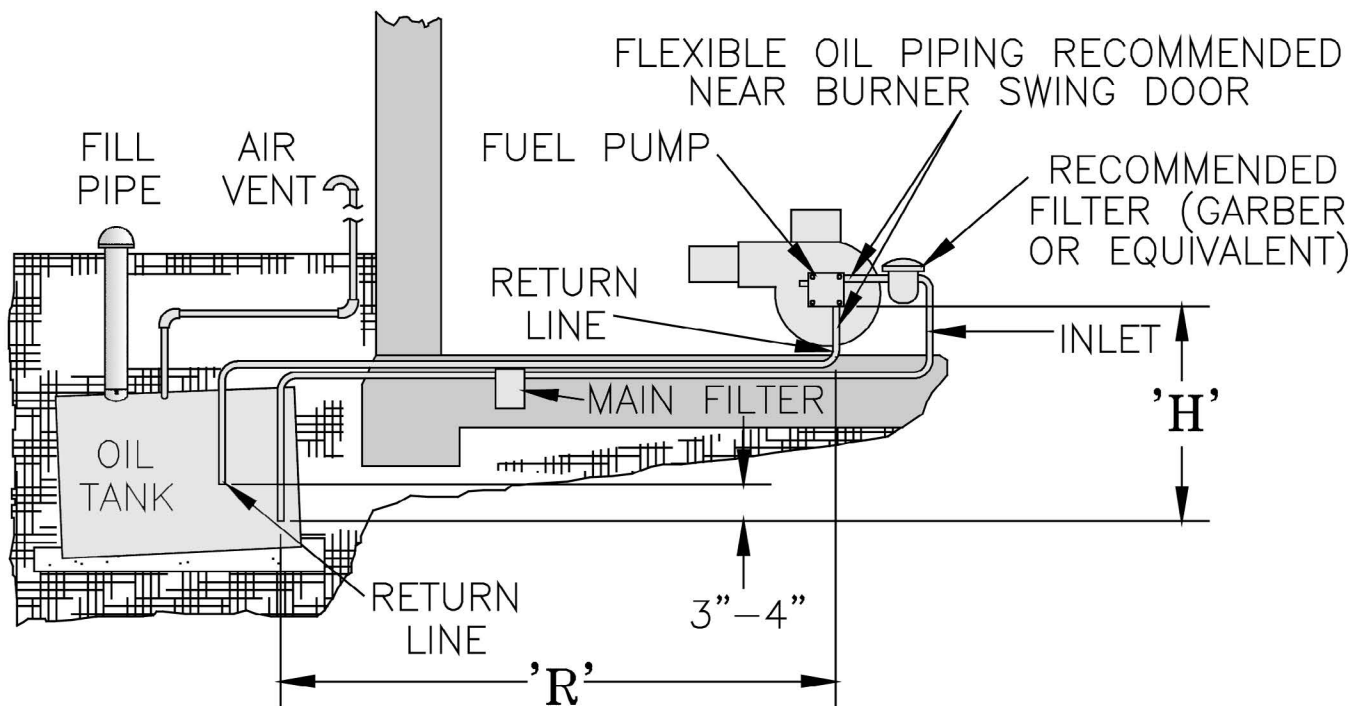

**Figure 9-4: Two Pipe Oil Lines**

# 10 System Start-Up

## WARNING

All boilers equipped with burner swing door have a potential hazard which can cause severe property damage, personal injury or loss of life if ignored. Before opening swing door, turn off service switch to boiler to prevent accidental firing of burner outside the combustion chamber. Be sure to tighten swing door fastener completely when service is completed.

### A. ALWAYS INSPECT INSTALLATION BEFORE STARTING BURNER.

1. Verify that the venting, water piping, oil piping, and electrical system are installed properly. Refer to Installation Instructions contained in this manual.
2. Confirm all electrical, water and oil supplies are turned off at the source and that the vent is clear from obstructions.

## WARNING

Completely read, understand and follow all instructions in this manual before attempting start up.

### B. FILL HEATING SYSTEM WITH WATER.

**NOTICE:** It is important, especially in a steam system, to properly remove the oil and dirt from the system. Failure to clean the system can result in erratic water lines and surging.

**CLEAN HEATING SYSTEM** if boiler water or condensate return water is dirty or if erratic water lines or surging exist after a few days of boiler operation.

Refer to Maintenance and Service Instructions Section of this manual for proper cleaning instructions for water boilers.

1. **HOT WATER BOILERS.** Fill entire heating system with water and vent air from system. Use the following procedure on a series loop or multi-zoned system installed as per Figures 5-2 and 5-3, to remove air from system when filling:
  - a. Close full port ball valve in boiler system piping.
  - b. Isolate all zones by closing zone valves or shut-off valves in supply and return of each zone(s).
  - c. Attach a hose to vertical purge valve in boiler system piping.  
(**Note** - Terminate hose in five gallon bucket at a suitable floor drain or outdoor area).
  - d. Starting with one zone at a time, open zone valve or shut-off valve in boiler supply and return piping.

- e. Open purge valve.
- f. Open shut-off valve in cold water supply piping located between the air scoop and expansion tank.
- g. Allow water to overflow from bucket until discharge from hose is bubble free for 30 seconds.
- h. When zone is completely purged of air, close zone valve or shut-off valve. Open zone valve to the next zone to be purged. Repeat this step until all zones have been purged. At completion, open all zone valves.
- i. Close purge valve, continue filling the system until the pressure gauge reads 12 psi. Close shut-off valve in cold water supply piping.

## WARNING

The maximum operating pressure of this boiler is posted on the ASME Data Label located on the top of the boiler. Never exceed this pressure. DO NOT plug safety or relief valve.

**NOTICE:** If make-up water line is equipped with pressure reducing valve, system will automatically fill to 12 psi. Follow fill valve manufacturer's instructions.

- j. Open full port ball valve in boiler system piping.
- k. Remove hose from purge valve.
- l. Confirm that the boiler and system have no water leaks.

### C. CHECK CONTROLS, WIRING AND BURNER

to be sure that all connections are tight and burner is rigid, that all electrical connections have been completed and fuses installed, and that oil tank is filled and oil lines have been tested.

### D. ADJUST CONTROL SETTINGS with burner service switch turned "ON".

1. SET ROOM THERMOSTAT about 10°F below room temperature.
2. PRESS RED RESET BUTTON on front of burner cover (Beckett, Riello burners) or Primary Control (Carlin Burner), hold button for one (1) second and release to reset primary control.

## 10 System Start-Up *(continued)*

3. WATER BOILERS WITHOUT TANKLESS HEATERS are equipped with an Intelligent Oil Boiler Control (Boiler Control). The Boiler Control is factory programmed with a High Limit setpoint of 180°F. The High Limit setpoint is adjustable between 140°F and 240°F. This temperature may be varied to suit the installation requirements
4. WATER BOILERS WITH TANKLESS HEATERS are equipped with a Warm Start Intelligent Oil Boiler Control (Warm Start Boiler Control). The Warm Start Boiler Control is factory programmed with a High Limit setpoint of 180°F. The High Limit setpoint is adjustable between 140°F and 240°F. Additionally, the Warm Start Boiler Control is factory programmed with a Low Limit setpoint of 110°F. The Low Limit setpoint is adjustable between 110°F and 220°F. These temperatures may be varied to suit the installation requirements.
5. CHECKOUT  
Put the system into operation and observe at least one complete cycle to make sure that the controller operates properly. See Troubleshooting Section to use LED to assist in determining system operation.

### E. ADJUST OIL BURNER BEFORE STARTING.

1. CHECK BURNER SETTINGS and readjust if necessary, see Burner Specifications, Table 16-1 at the rear of this manual.

### F. START OIL BURNER.

1. Open vent fitting on fuel pump.
2. TURN 'ON' BURNER service switch and allow burner to run until oil flows from vent fitting in a SOLID stream without air bubbles for approximately 10 seconds.
3. Close vent fitting and burner flame should start immediately after prepurge is completed. Prepurge prevents burner flame until 10 seconds has elapsed after initial power is applied to burner. During prepurge the motor and igniter will operate but the oil valve will remain closed. Refer to Oil Primary Control Instructions for more details.
4. Adjust oil pressure.
  - a. When checking a fuel unit's operating pressure, a reliable pressure gauge may be installed in either the bleeder port or the nozzle port.

- b. Locate oil pressure adjusting screw and turn screw to obtain proper pump pressure, refer to Table 16-1 at the rear of this manual.
- c. To check the cutoff pressure, deadhead a reliable pressure gauge onto the copper connector tube attached to the nozzle port. Run the burner for a short period of time. Shut the burner off. The pressure should drop and hold.
- d. Remove the gauge and install bleeder port and/or reconnect the nozzle port line.

### G. ADJUST OIL BURNER WHILE OPERATING.

(flame present)

1. SET ROOM THERMOSTAT about 10°F below room temperature.
2. PRESS RED RESET BUTTON on Oil Primary Control and release.
3. READJUST THE HEAD SETTING only if necessary.
4. ADJUST DRAFT REGULATOR for a draft of -0.02 in. (water gauge) over the fire after chimney has reached operating temperature and while burner is running.

### **WARNING**

DO NOT loosen or remove any oil line fittings while burner is operating.

5. READJUST THE AIR SETTING on the burner for a light orange colored flame while the draft over the fire is -0.02 in. Use a smoke tester and adjust air for minimum smoke (not to exceed #1) with a minimum of excess air. Make final check using suitable instrumentation to obtain a CO<sub>2</sub> of 11.5 to 13.0% with draft of -0.02 in. (water gauge) in fire box. These settings will assure a safe and efficient operating condition. If the flame appears stringy instead of a solid fire, try another nozzle of the same type. Flame should be solid and compact. After all adjustments are made, recheck for a draft of -0.02 in. over the fire.
6. FLAME FAILURE  
The V8H boiler controls operate the burner automatically. If for unknown reasons the burner ceases to fire and the reset button on the primary control has tripped, the burner has experienced ignition failure. Refer to Oil Primary Control features, Paragraph I, Step 2 of this Section and Section 15, Troubleshooting, Paragraph B. If the failure re-occurs, call your heating contractor immediately before pressing the reset button.

## 10 System Start-Up *(continued)*

### **⚠ WARNING**

DO NOT attempt to start the burner when excess oil has accumulated, when the boiler is full of vapor, or when the combustion chamber is very hot.

#### **H. CHECK FOR CLEAN CUT OFF OF BURNER.**

1. AIR IN THE OIL LINE between fuel unit and nozzle will compress when burner is on and will expand when burner stops, causing oil to squirt from nozzle at low pressure as burner slows down and causing nozzle to drip after burner stops. Usually cycling the burner operation about 5 to 10 times will rid oil line of this air.
2. IF NOZZLE CONTINUES TO DRIP, repeat Paragraph H, No. 1 above. If this does not stop the dripping, remove cut-off valve and seat, and wipe both with a clean cloth until clean, then replace and readjust oil pressure. If dripping or after burn persist replace fuel pump.

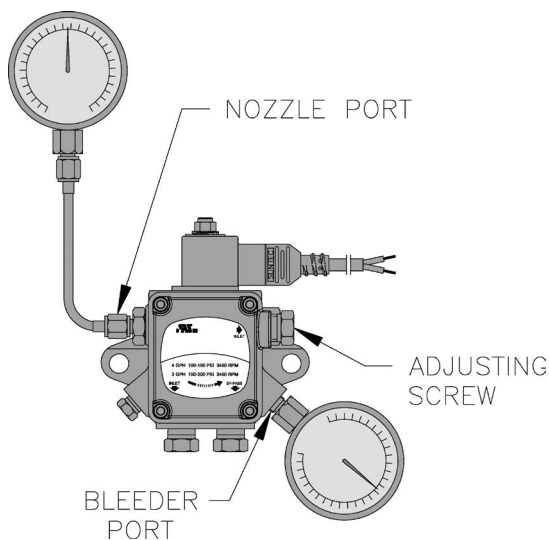

**Figure 11-1: Adjusting Fuel Pump Pressure**

#### **I. TEST CONTROLS.**

1. Check thermostat operation. Raise and lower thermostat setting as required to start and stop burner.

### **⚠ WARNING**

Before installation of the boiler is considered complete, the operation of all boiler controls must be checked, particularly the primary control and high limit control.

#### **2. VERIFY OIL PRIMARY CONTROL FEATURES**

using procedures outlined in Instructions furnished with control or instructions provided with burner.

#### **3. CHECK HIGH LIMIT**

- a. Adjust system thermostat(s) to highest setting.
- b. Allow burner to run until boiler water temperature exceeds high limit setting. The burner should shut down and circulators continue running.
- c. Allow the temperature to drop below control setting. The burner must restart.
- d. Boiler installation is not considered complete until this check has been made.
- e. Check operating control on boiler applications equipped with tankless heater(s). With burner off, draw hot water until burner starts, then turn off hot water and check burner shut-down.

#### **J. IF CONTROLS MEET REQUIREMENT** outlined in Paragraph I.

1. Allow boiler to operate for approximately 30 minute, confirm the boiler and system have no leaks.

#### **K. IF CONTROLS DO NOT MEET**

**REQUIREMENTS** outlined in Paragraphs I-1 thru I-6, replace control and repeat checkout procedures.

# 11 Operating

## A. WATER BOILERS SEQUENCE OF OPERATION

### 1. Water Boilers Without Tankless Heaters

(Cold Start), Sequence Of Operation:

- a. The V8H Boiler is equipped with a Cold Start Intelligent Oil Boiler Control (Cold Start Boiler Control). The Cold Start Boiler Control replaces the traditional electronic aquastat and circulator relays and adds energy saving thermal purge features. Energy is saved by starting the circulator and delaying the burner start when there is residual heat available in the boiler.
- b. The boiler's sequence of operation is shown as Status Codes on Cold Start Boiler Control display. See Table 11-3 and Figure 11-2.
- c. When the thermostat calls for heat the boiler control starts the system circulator and the thermal purge (circulator pre-purge time) begins. If the time is completed or boiler temperature is less than the Start Temperature (140°F default) the start sequence continues by energizing the oil primary to operate the following sequence: blower is started and operates for pre-purge time; spark is energized and fuel valve is opened for ignition trial time; burner fires until the thermostat is satisfied.
- d. If the thermostat is not satisfied and the Operating Setpoint (SP) is reached the system circulator will continue to operate and the burner will stop. When the boiler water temperature drops below the setpoint less the differential setting the burner will restart.
- e. After the thermostat is satisfied the burner and circulator are stopped.
- f. When an indirect water heater aquastat call for heat is wired to the "ZR" terminal the Boiler Control starts a domestic hot water circulator connected to the "ZC" terminal and when the boiler temperature is less than Operating Setpoint (SP), the Cold Start Boiler Control energizes the oil primary to turn on the burner without circulator pre-purge delay.
- g. On burner start, if the CAD cell does not see flame within approximately 15 seconds, primary control will shut down the burner and enter into a lockout mode. A lockout is reset by pressing the reset button located on the primary control. If the flame is lost while the burner is firing, the primary control shuts down the burner, enters a 60 second

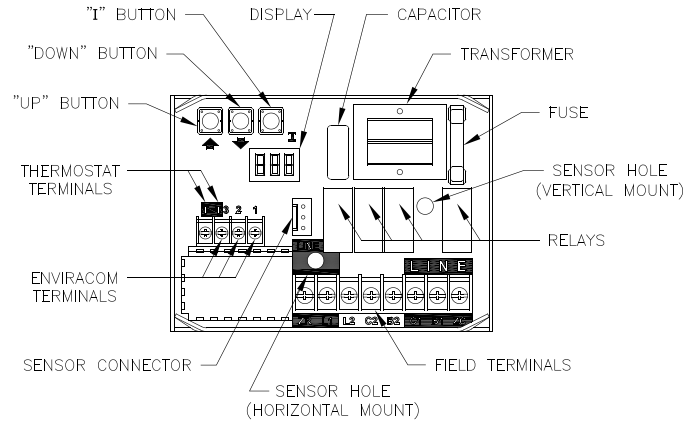

Figure 11-2: Intelligent Oil Boiler Control

recycle delay, and repeats the ignition sequence. If after three (3) trials for ignition, flame is not detected, primary control will enter into restricted mode. Restricted mode is reset by holding down the reset button for 15 seconds.

### 2. Water Boilers with Tankless Heaters (Warm Start), Sequence Of Operation:

- a. The V8H Boiler is equipped with a Warm Start Intelligent Oil Boiler Control (Warm Start Boiler Control). The Warm Start Boiler Control replaces the traditional high and low limit aquastat and circulator relays.
- b. The boiler's sequence of operation is shown as Status Codes on Warm Start Boiler Control display. See Table 11-3 and Figure 11-2.
- c. When the thermostat calls for heat the Warm Start Boiler Control starts the system circulator and the start sequence continues by energizing the oil primary to operate the following sequence: blower is started and operates for pre-purge time; spark is energized and fuel valve is opened

Table 11-3: Sequence of Operation

Status Codes Displayed in 5tR Mode		
5tR	Status	Description
i	Standby (burner off, pump off)	No call for heat detected
i	Standby (burner off, pump on)	Either condition is true: a. Call for heat detected and boiler temperature higher than operating setpoint. b. Call for heat detected and boiler temperature higher than 140 F and Pump Pre-Purge Time has not expired.
8	Running	The burner runs until the call for heat is satisfied.
∏	Self Test	Control internal checking

## 11 Operating *(continued)*

- for ignition trial time; burner fires until the thermostat is satisfied. Optionally, the thermal purge (circulator pre-purge time) maybe added adjusting the Circulator Pre-purge time parameter. This feature saves energy by starting the circulator and delaying the burner start when there is residual heat available in the boiler.
- If the thermostat is not satisfied and the Operating Setpoint (SP) is reached the system circulator will continue to operate and the burner will stop. When the boiler water temperature drops below the setpoint less the differential setting the burner will restart.
  - After the thermostat is satisfied the burner and circulator are stopped.
  - The Warm Start Boiler Control also includes a low limit control function. When the boiler water temperature falls below the Low Limit Setpoint less the Low Limit Differential the "ZC" terminal and System Circulator outputs are de-energized and the oil primary is energized to start the burner. As temperature rises above the Low Limit Setpoint the burner is stopped, the "ZC" output is energized and the System Circulator is enabled to run in response to a call for heat.
  - On burner start, if the CAD cell does not see flame within approximately 15 seconds, primary control will shut down the burner and enter into a lockout mode. A lockout is reset by pressing the reset button located on the primary control. If the flame is lost while the burner is firing, the primary control shuts down the burner, enters a 60 second recycle delay, and repeats the ignition sequence. If after three (3) trials for ignition,

flame is not detected, primary control will enter into restricted mode. Restricted mode is reset by holding down the reset button for 15 seconds.

### 3. Using Cold or Warm Start Boiler Control (Boiler Control) Features

The Boiler Control is located on front of boiler. The Boiler Control display, along with Up ↑, Down ↓, and "I" keys may be used to view boiler operating status (Figure 11-4).

### 4. Viewing the Operating Mode Options

In operating mode the user may view (but not change) boiler operating status, settings and troubleshooting information. To view Boiler Control display information:

Press and release the "I" key on the Boiler Control to change from one parameter to the next. Each setting will alternately flash between the relevant display code and its corresponding value.

Operating Mode Options	
	Status Numbers: I Standby B Running I7 Self Test)
StA	Boiler Temperature
bE	Boiler Temperature
SP	Operating Setpoint (Outdoor Reset)
HL	High Limit Setting
HdF	High Limit Differential
LL	Low Limit Setpoint (warm start only)
LdF	Low Limit Differential (warm start only)
hr	Heat Request Status
dh	DHW Request Status
Err	Boiler Error

For example, when the "I" key is pressed on the Boiler Control until "bE" is displayed, it will then flash a three digit number (such as "180") followed by either "F" (or "E"). This indicates that the boiler water temperature is 180°F. Other operating parameters display the information in a similar fashion.

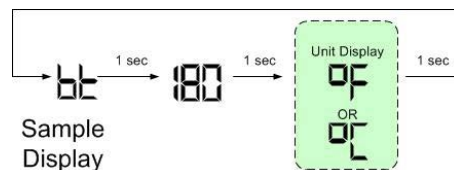

Please note that in operating mode to hold the display on the value the user can press and hold either the Up ↑ or Down ↓ keys and the value will be continuously shown. This may be helpful in watching a value "live".

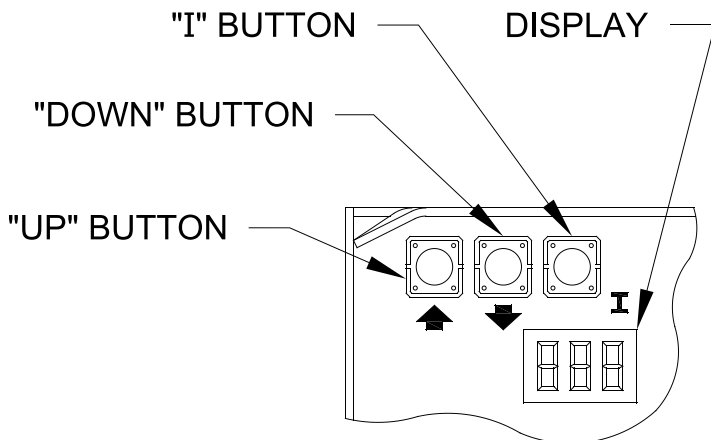

**Figure 11-4: Boiler Control Key Function & Orientation**

# 11 Operating *(continued)*

## 5. Changing the Adjustable Parameters

To adjust parameters such as the High Limit Setpoint and High Limit Differential:

- a. Using the Boiler Control display, access the adjustment mode by pressing and holding the Up ↑, Down ↓, and “**⏏**” keys simultaneously for three (3) seconds. This procedure is intended to discourage unauthorized changes or accidental changes to limit settings.
- b. Press the “**⏏**” key to display available Adjustment Mode options. Select an option.

Cold Start Boiler Control Adjustment Mode Options		
HL_	140-240°F	Adjust High Limit Setting
HdF	10-30°F	Adjust High Limit Differential
ZC_	dh, Zr or ELL	ZC and ZR Terminal Function
Or_	0-10 minutes	Pump Overrun Time
PP_	2-20 minutes	Pump Pre-purge Time
St_	140 - 180°F	Start Temperature
Pt_	On or Off	Priority Time
F-C	F or C	Select degrees F or C Mode
bRc		Back to Operating Mode

Warm Start Boiler Control Adjustment Mode Options		
HL_	140-240°F	Adjust High Limit Setting
LL_	110-220°F	Adjust Low Limit Setting
LdF	10-25°F	Adjust Low Limit Differential Setting
ZC_	Zr or dh	ZC and ZR Terminal Function
Or_	0-10 minutes	Pump Overrun Time
PP_	0-20 minutes	Pump Pre-purge Time
St_	140 - 180°F	Start Temperature
Pt_	On or Off	Priority Time
F-C	F or C	Select degrees F or C Mode
bRc		Back to Operating Mode

- c. Press the Up ↑ and Down ↓ keys to adjust the displayed setpoint to the desired value.
- d. To return to the normal operating mode from the Adjustment Mode, when the “bRc” option is displayed, press either the Up ↑ or Down ↓ key. If no keys are pressed, after five (5) minutes the Boiler Control will automatically return to the Operating Mode.

## 6. More Information about Adjustable Parameters

- a. High Limit (HL\_)
 

The Boiler Control is factory programmed with a High Limit Setpoint of 180°F. The boiler turns "off" when the boiler water temperature (bT) is above this value. The High Limit setpoint is adjustable between 140° and 240°F. The Operating Setpoint (5P)

will equal the High Limit Setpoint.

- b. High Limit Differential (HdF)
  - i. The Cold Start Boiler Control is factory programmed with a Differential of 15°F. The Differential is the number of degrees the boiler temperature must decrease below the Operating Setpoint before the boiler can restart. The differential is adjustable between 10° and 30°F.
  - ii. On Warm Start Boiler Control the High Limit Differential is not adjustable and is fixed at 10°F.

### c. Low Limit (LL\_)

The Warm Start Boiler Control is factory programmed with a Low Limit Setpoint of 110°F. On falling temperature the boiler turns “on” and the “ZC” terminal and System Circulator outputs are de-energized when the boiler temperature is less than the Low Limit Setpoint less the differential. On a rising temperature when the boiler temperature is above the Low Limit Setpoint the boiler turns “off”, the “ZC” terminal output is energized and the System circulator is enabled to respond to a call for heat. The Low Limit Setpoint is adjustable between 110°F and 220°F.

### d. Low Limit Differential (LdF)

The Warm Start Boiler Control is factory programmed with a Low Limit Differential Setpoint of 10°F. The Low Limit Differential is the number of degrees the boiler temperature must decrease below the Low Limit Setpoint before the Warm Start Boiler Control takes actions to warm the boiler. These actions include starting the burner and stopping water flow through the boiler. The Low Limit Differential is adjustable between 10°F and 25°F.

### e. Circulator Overrun Time (Or\_)

Circulator Overrun Time (also called “circulator off delay” or “circulator post purge”) continues circulator operation after a call for heat has ended, sending excess heat from the boiler into the priority zone. Ensure system piping and zone panel settings allow water flow to the priority zone after the call for heat ends. The Circulator Overrun Time has a factor setting of 0 minutes and is field adjustable between 0 and 10 minutes.

# 11 Operating *(continued)*

**Table 11-5: Circulator Pre-Purge Time Example, Parameter PP\_ = 2 Minutes**

Call for Heat	ZC and ZR Terminal Function (ZC_)	Boiler Temp.	Boiler Status, (B1 Output)
TT = on	--	< 140	Start with no delay
TT = on	--	> 140	Start after 2 minute delay
ZR = on	ZC_ = Zr	< 140	Start with no delay
ZR = on	ZC_ = Zr	> 140	Start after 2 minute delay
ZR = on	ZC_ = dH	< 140	Start with no delay
ZR = on	ZC_ = dH	> 140	Start with no delay

f. Circulator Pre-Purge Time (PP\_)

When the boiler is warm [boiler water temperature higher than 140°F (adjustable using Start Temperature parameter)] and there is a thermostat call for heat, the system circulator is started and boiler firing is delayed pre-purge minutes. If the temperature drops below 140°F or there is a DHW Call for Heat the boiler is started without delay. Additionally, the boiler is started without delay if the thermostat call for heat is initiated when the boiler water temperature is less than 140°F. This feature helps save energy by satisfying home heating needs with residual boiler heat rather than cycling the boiler. The Circulator Pre-purge time has a factory setting of 2 minutes and is field adjustable between 2 and 20 minutes. Refer to Table 11-5.

The Warm Start Boiler Control Pre-purge Time is factor set to 0 minutes.

g. Start Temperature (St\_)

The amount of "Heat available" is calculated by taking the difference between measured boiler water temperature and the Start Temperature setting. Useful "Heat Available" is dependent on the type of heating emitter installed in the home. Heat emitters require a certain minimum temperature to operate effectively. Our default settings reflect cast iron radiators. Fan Coils may require a start temperature setting of 180°F or 160°F before providing heat to the home. The Start Temperature has a factory setting of 140°F and is field adjustable between 140°F and 180°F.

h. Priority Time (Pt\_)

When the Priority Time parameter is set to "on" and Domestic Hot Water (DHW) call for heat is "on" the DHW demand will take "Priority" over home heating demand and

**Table 11-6: Domestic Hot Water Demand, (Parameter ZC\_ = dH)**

Call for Heat		Priority Time (Pt_)	Circulator Status	
T-T Input	ZR Input		System Circulator Output	DHW Circulator ZC Output
on	off	On	on	off
on	on	On	off	on
off	on	On	off	on
on	off	OFF	on	off
on	on	OFF	on	on
off	on	OFF	off	on

the system circulator will be forced "off". Priority Time ends and the system circulator is released to service home heating demand when Domestic Hot Water call for heat is over. When Priority Time parameter is set to "Off" the DHW call for heat does not force "off" the system circulator. The Priority Time has a factory setting of "On" and is field adjustable between "On" and "Off". Refer to Table 11-6.

i. "ZC" and "ZR" Terminal Function (ZC\_)

The boiler control allows configuration of the "ZC" output functionality to help the V8H integrate into each installation more effectively. The "ZC" output can be connected to a domestic hot water circulator or a second heating zone circulator or be used to enable pumps in a warm start application. These applications are selected as follows:

i. When ZC\_ is set equal to Domestic Hot Water Demand (dH)

When there is an Indirect Water Heater (IWH) the boiler control provides a "ZR" input terminal for the IWH Aquastat and "ZC" output terminal for the DHW Circulator. When there is a DHW call for heat, the System Circulator is "forced off", the DHW Circulator terminal is energized and the circulator pre-purge time delay control logic is bypassed to allow the boiler to fire without delay. When DHW demand ends the System Circulator "force off" is removed, the circulator can respond normally, and the DHW Circulator is de-energized. The DHW call for heat is detected by a voltage on to the "ZR" terminal. When a Priority Time parameter is set to "off" the System Circulator is not forced off for a DHW call for heat. Refer to Table 11-6.

# 11 Operating *(continued)*

**Table 11-7: Zone Request, Parameter  $\mathcal{Z}_{C-} = \mathcal{Z}_r$**

Call for Heat		Circulator Status	
T-T Input	ZR Input	C1 Output	ZC Output
off	off	off	off
on	off	on	off
on	on	on	on
off	on	off	on

- ii. When  $\mathcal{Z}_{C-}$  is set equal to Zone Request ( $\mathcal{Z}_r$ )

When there is no IWH the Cold Start Boiler Control "ZC" output may be configured to control a second heating zone. This is particularly helpful when the home uses only two heating zones. The Cold Start Boiler Control replaces the need for a two circulator zone panel. When DHW Terminal Function ( $\mathcal{d}h_{-}$ ) is set to  $\mathcal{Z}_r$  the boiler control's two circulator outputs are used to control two independent heating zones. Refer to Table 11-7. A "TT" input causes a call for heat and energizes the System Circulator output to service heating zone 1. A second zone's thermostat may be wired to the "ZR" input to energize heating zone 2 circulator wired to the "ZC" output. Both outputs function independently, "TT" input controls only the System Circulator output and the "ZR" input controls only the "ZC" output. Both inputs cause a boiler call for heat.

The Warm Start Boiler Control with  $\mathcal{Z}_{C-}$  set equal to Zone Request ( $\mathcal{Z}_r$ ) energizes the "ZC" terminal while the boiler is warm as described earlier in this section (refer to Paragraph A, Step 2, Item f). The "ZR" input is a call for heat that starts the boiler.

- iii. External Low Limit, Parameter  $\mathcal{Z}_{C-} = E_{LL}$
- The Cold Start Boiler Control is capable of functioning as a warm start control when external limit control is installed that closes a contact when boiler water temperature falls below a setpoint. When an external limit contact closes (boiler water is cold) the boiler is started and the "ZC" and "C1" output terminals are de-energized. When the "ZR" terminal is de-energized (boiler water temperature is above setpoint) the call for heat is ended and the "C1" terminal is released to operation and the "ZC" terminal is energized. An External Low

**Table 11-8: External Low Limit, Parameter  $\mathcal{Z}_{C-} = E_{LL}$**

Call for Heat		Circulator Status	
T-T Input	ZR Input	C1 Output	ZC Output
off	off	off	on
on	off	on	on
on	on	off	off
off	on	off	off

Limit Request is detected by sensing a voltage on the "ZR" terminal. The Warm Start Boiler Control does not have the External Low Limit Option. Refer to Table 11-8.

## B. HydroStat 3250 PLUS SEQUENCE OF OPERATION

**IMPORTANT** This boiler is equipped with a feature that saves energy by reducing the boiler water temperature as the heating load decreases.

This feature is equipped with an override which is provided primarily to prevent the use of an external energy management system that serves the same function. THIS OVERRIDE MUST NOT BE USED UNLESS AT LEAST ONE OF THE FOLLOWING CONDITIONS IS TRUE:

- An external energy management system is installed that reduces the boiler water temperature as the heating load decreases.
- This boiler is not used for any space heating.
- This boiler is part of a modular or multiple boiler system having a total input of 300,000 BTU.HR or greater.
- This boiler is equipped with a tankless coil.

### 1. Setting the Control

- Setting the High Limit: The high limit is factory set at 190°F. To adjust, turn the HI TEMP Dial A until the desired setting is displayed. (Setting range: 100°-220°F).
- Setting the Low Limit: The low limit is designed to maintain temperature in boilers equipped with tankless coils used for domestic hot water. The low limit is factory set to OFF. Prior to adjusting, remove the jumper (not equipped on all units) B. Then turn the LP TEMP Dial C clockwise until the desired temperature is displayed. For proper operation, the low temperature limit setting should be least 10° below the high limit setting. NOTE: For cold start operation, the low limit must be turned OFF.

# 11 Operating *(continued)*

**IMPORTANT:** If low limit temperature cannot be set above 140°F, remove jumper B. (Setting range: OFF or 110° -200° F).

- c. Setting the Economy Feature: The Economy Feature is factory set for a 1 zone heating system. To adjust, turn the ECONOMY Dial D until the number displayed equals the number of heating zones. Do not include indirect water heaters in the number of heating zones. The Economy Feature conserves fuel by reducing boiler temperature (see "How Thermal Targeting Works". If the heating system is unable to supply needed heat to the house, the ECONOMY Dial should be turned to a lower setting (example: In a three zone house, turn the dial to 2 or 1.) Conversely, if the boiler provides adequate heat, added fuel savings can be achieved by selecting a higher setting (example: 4 or 5). If the heating and indirect water heater signals were not separated when wiring the control, the Economy Feature should be turned OFF to ensure the boiler supplies adequate temperature to heat the indirect tank.
- d. Setting the Zone/Indirect Switch: See WIRING.

Setting	
Off	Disables economy function. Will allow boiler to fire until hi-limit temp is reached and re-fire with a 10° subtractive differential
LO	Provides lowest level of fuel savings. Use this setting only if the house does not stay warm at higher settings.
1	Recommended setting for single zone systems
2	Recommended setting for Two zone systems
3	Recommended setting for Three zone systems
4	Recommended setting for Four zone systems
5	Recommended setting for Five zone systems
HI	Provides highest level of fuel savings

- e. Optional Features: NOTE: The Program Mode-Pro - is accessed by turning the LP TEMP dial to a position just above OFF.
2. Thermal Pre-Purge: Thermal Pre-Purge is designed to maximize boiler efficiency. When activated, the control will supply latent heat that may remain in the boiler from a previous run cycle to the heating zone that is now calling. The control monitors how quickly the boiler temperature is declining and activates the burner only when it determines that the latent heat is insufficient to satisfy the call. During the purge cycle, the display will indicate Pur.

This feature works with single-zone and multi-zone heating systems utilizing circulators or zone valves. No change in wiring is needed.

### To activate Thermal Pre-Purge

- Turn the LO TEMP dial to access the Program Mode - indicated in the display as Pro.
  - Turn the HI TEMP dial to select feature 1.
  - Push the Test/Setting Button to turn Thermal Pre-Purge ON or OFF.
  - Reset LO TEMP and HI TEMP settings to desired temperatures.
3. Degrees Fahrenheit or Celsius: The control has the ability to operate in degrees Fahrenheit or Celsius. When operating in Celsius, a c will appear in the display next to the temperature whenever the temperature is below 100 degrees.
- To change between degrees Fahrenheit and degrees Celsius
- Turn the LO TEMP dial to access the Program Mode - indicated in the display as Pro.
  - Turn the HI TEMP dial to select feature 2.
  - Push the Test/Setting Button to c for Celsius or F for Fahrenheit.
  - Reset LO TEMP and HI TEMP settings to 3desired temperatures.
4. Manual Reset Low Water Cut-Off: The low water cut-off operation on the HydroStat can be set to operate in automatic (default) or manual reset mode. When in manual reset mode, the control will shut-down the burner immediately when low water condition is detected. If the low water condition is sustained for 30 seconds, the low water light will blink, indicating that the control has locked out the burner. The control can only be reset by pushing the Test Settings button on the top of the control. The manual reset feature meets CSD-1 code requirements.

**IMPORTANT:** The system must be checked by a qualified heating professional prior to resuming operation.

# 11 Operating *(continued)*

## WARNING: DO NOT ADD WATER UNTIL THE BOILER HAS FULLY COOLED.

### To activate Manual Reset LWCO mode

- Turn the LO TEMP dial to access the Program Mode - indicated in the display as Pro
- Turn the HI TEMP dial to select feature 3
- Push the Test/Setting Button to A for Automatic Reset Mode
- Reset LO TEMP and HI TEMP settings to desired temperatures.

To Test the Manual Reset Feature: Press and hold the Test/Settings button located on the top of the control for 30 seconds to simulate a low water condition. After 30 seconds, the Low Water light will blink indicating that the control is locked out. To reset the lock-out condition, press the Test/Setting button momentarily.

### 5. Circulator Activation Options

When in the default mode, the HydroStat activates the circulator (**C1/C2** contacts) on calls to **TT**. The control can be programmed to activate the circulator on calls to **ZC/ZR** in place of, or in addition to **TT**.

### To change how the Circulator is activated

- Turn the LO TEMP dial to access the Program Mode - indicated in the display as Pro.
- Turn the HI TEMP dial to select feature 4.
- Push the Test/Setting Button to select between the following options:
  - A - Circulator on **TT** call only
  - b - Circulator on **ZC/ZR** calls
  - C - Circulator on both **TT** & **ZC/ZR** calls
- Reset LO TEMP and HI TEMP settings to desired temperatures.

### 6. Circulator Hold Off (Enhanced Condensing Protection)

To reduce the potential for condensing, On a call for heat the control will allow the boiler to heat to 125°F prior to energizing the circulator. Once energized, the circulator will remain on for the duration of the heating call unless the boiler temperature drops below 115°F. If this occurs, the circulator will re-energize when the boiler returns to 125°F. Circulator Hold Off will expire after 15 minutes.

### To activate Circulator Hold Off

- Turn the LO TEMP dial to access the Program Mode - indicated in the display as Pro.
- Turn the HI TEMP dial to select feature 5.
- Push the Test/Setting Button to Circulator Hold Off ON or OFF.

- Reset LO TEMP and HI TEMP settings to desired temperatures.

### 7. Setting the Well Type (Electro-Well vs. Standard Immersion Well)

When used to replace older temperature-only controls, the HydroStat can be installed on the existing well. (The Hydrolevel Electro-Well is required to activate low water cut-off operation. Older wells may contain hardened heat transfer grease or other contaminants that could interfere with metal-to-metal continually between the sensor head and the inside of the well. Insufficient contact could lead to false low water conditions and burner shut downs. Setting the well type to Standard Well prevents the possibility of this occurring.

### To change the well type

- Turn the LO TEMP dial to access the Program Mode - indicated in the display as Pro.
- Turn the HI TEMP dial to select feature 8.
- Push the Test/Setting Button to select A for Electro-Well or b for Standard Well.

NOTE: To ensure that the low water cut-off is always active when the control is installed on an Electro-Well, setting b will ONLY be available when installed on a standard well. The HydroStat sensor checks to determine if a standard well is used by looking for low resistance to ground, a condition that can only exist with a standard well. If you are installing on a standard well and either Low Water LED's are on, setting b will not be available. Check to see if the inside of the well tube is badly oxidized or contaminated with heat transfer grease. It may be necessary to clean the well to allow for setting b to be selected (See Troubleshooting Guide for more information).

### 8. High Limit Differential

When the Economy feature is on, the control's Thermal Targeting feature actively sets varying differentials based on system conditions. This option allows for selecting a 10, 20 or 30 degree fixed differential when the Economy feature is turned OFF. These optional differential settings are subtractive from the HIGH LIMIT setting. **Note:** If the Economy feature is on, this setting will be overridden by the control's Thermal Targeting function.

### To change the high limit differential

- Turn the LO TEMP dial to access the Program Mode - indicated in the display as Pro.
- Turn the HI TEMP dial to select feature 9.
- Push the Test/Setting Button to select a high limit differential of 10, 20, or 30.

# 11 Operating *(continued)*

Dial Setting	Feature	Options	Description	Default Setting
1	Thermal Pre-Prurge	OFF ON	Purge Inactive Purge Active	OFF
2	Fahrenheit or Celsius	F C	Degrees Fahrenheit Degree Celcius	F
3	LWCO Manual or Automatic Reset	A b	Automatic Reset Manual Reset	A
4	Circulator Options	A b c	Circulator operation on TT call only Circulator operation on ZC/ZR call only Circulator operation on call from either	A
5	Circulator Hold Off	ON OFF	Circulator Hold Off - Active Circulator Hold Off - Inactive	ON
6	Not available on this control			
7	Not available on this control			
8	Well Type	A b	Hydrolevel Electro-Well Standard Immersion Well	A
9	High Limit Differential	10 20 30	10° Differential 20° Differential 30° Differential	10
dEF	Restore Factory Defaults	Y N	Restore Defaults Do Not Restore Defaults	n

NOTE: If the HydroStat is factory-equipped on a boiler, some options may be set differently from the default settings. Not all features are available on older HydroStat models.

- d. Reset LO TEMP and HI TEMP settings to desired temperatures.
9. Restore Factory Default Settings  
*To restore all features to the factory default settings (see following chart for default settings)*
  - a. Turn the LO TEMP dial to access the Program Mode - indicated in the display as Pro
  - b. Turn the HI TEMP dial to select feature dEF
  - c. Push the Test/Setting Button to Y to reset all features to the default settings
  - d. Reset LO TEMP and HI TEMP settings to desired temperatures.
10. LED Legend and Test/Settings Button
  - a. TEMP ACTIVE Indicates that the Fuel Smart HydroStat control is powered and that the temperature function is active.
  - b. TEMP HI TEMP Illuminates when the boiler water temperature reaches the high limit setting. It will remain lit until the water temperature falls 10°. The Fuel Smart HydroStat prevents burner operation while this LED is on. See Differential explanation.
  - c. LWCO ACTIVE Indicates that the low water cut-off (LWCO) function of the Fuel Smart HydroStat is active. When the control is installed with a Hydrolevel Electro-Well™, this LED will be on at all times when the control is powered. **IMPORTANT:** If the control is installed with a well other than the Electro-Well™, this LED will not illuminate indicating that the control is not providing low water cut-off functionality.
  - d. LWCO LOW WATER Indicates that the boiler is in a low water condition. The HydroStat control will prevent burner operation during this condition. If the LOW WATER light is blinking, the control has been programmed to provide lockout protection in the event a low water condition is detected (see Manual Reset Low Water Cut-Off). Pressing the TEST/SETTINGS button will reset the control. **IMPORTANT:** The system must be checked by a qualified heating professional prior to resuming operation.

# 11 Operating *(continued)*

## WARNING

Allow the boiler to fully cool before adding water.

- e. **ECONOMY ACTIVE** Indicates that the Thermal Targeting function is active and the Fuel Smart HydroStat will reduce boiler temperature to conserve fuel. The Economy feature is activated using the ECONOMY dial. (See “How Thermal Targeting Works” for more information).
- f. **ECONOMY TARGET** When the Economy feature is active, the Fuel Smart HydroStat continually sets target temperature below the high limit setting to maximize fuel efficiency. When the boiler water reaches the target temperature, the LED illuminates and the burner will shut down. The boiler water will continue to circulate and heat the house as long as the thermostat call continues. The LED will stay lit until the boiler temperature drops below the differential set point at which point the boiler will be allowed to fire again. See Differential explanation.

**NOTE:** This LED illuminates regularly during normal boiler operation.

- g. **TEST/TESTING Button**  
**To Test Low Water Cut-Off:** Press and hold the Test/Settings button for 5 seconds. The display will read LCO.

## LWCO TEST LCO

The red Low Water light should illuminate and the burner circuit (B1 and B2) should de-energize.  
**NOTE:** The control must be installed with a Hydrolevel Electro-Well™ for low water cut-off functionality.

**To View Current Settings:** Press and release the Test/Settings Button in short intervals to sequentially display the following settings:

HIGH LIMIT SETTING HL



LOW LIMIT SETTING LL



ECONOMY SETTING ECO



CURRENT TARGET TEMPERATURE 000

The display will return to boiler temperature (default) if Test/Settings Button is not pressed for 5 seconds.

# 11 Operating *(continued)*

## Important Product Safety Information: Refractory Ceramic Fiber Product

### WARNING

Some boiler components use materials that contain refractory ceramic fibers (RCF). RCF has been classified as a possible human carcinogen. When exposed to elevated temperatures, RCF may change into crystalline silica, a known carcinogen. When disturbed as a result of servicing or repair, these substances become airborne and, if inhaled, may be hazardous to your health. Avoid breathing RCF particulates and dust.

#### Precautionary Measures:

- Do not handle RCF parts or attempt any service or repair work involving RCF without wearing the following protective gear:
  1. A properly fitting National Institute for Occupational Safety and Health (NIOSH)-certified air-purifying respirator with a filter efficiency of at least 95%. Respirator should also include a full facepiece when handling used RCF. Other types of respirators may be required depending on site conditions. Current NIOSH recommendations may be found on the NIOSH website <http://www.cdc.gov/niosh/homepage.html>. NIOSH-approved manufacturers, respirators and associated user instructions are listed on the NIOSH website.
  2. Long sleeved, loose fitting clothing that is sufficiently tight around potential entry points for RCF dust.
  3. Gloves.
  4. Eye protection, such as goggles, safety glasses with side shields, or full facepiece.
- Take steps to assure adequate ventilation.
- Handle RCF carefully to minimize airborne dust. Use hand tools whenever possible.
- Dampen used RCF with light water spray prior to removal to prevent airborne dust.
- Do not use compressed air or dry sweeping for clean-up. Frequently clean work area with a vacuum or by wet sweeping to minimize debris accumulation.
- Vacuum work clothes before leaving work area. Wash work clothes separately from other laundry and rinse washing machine after use to avoid contaminating other clothes.
- Wash all exposed body areas gently with soap and water after contact.
- Discard used RCF components by sealing in an airtight plastic bag or container. Refer to local, regional, state or provincial regulations to identify applicable disposal requirements.

#### First Aid Procedures:

- Eye contact: Flush with water for at least 15 minutes. Do not rub eyes. Seek immediate medical attention if irritation persists.
- Skin contact: Wash affected area gently with soap and water. Do not rub or scratch affected skin. Seek immediate medical attention if irritation persists.
- Nose and throat contact: If these become irritated, leave the area and move to a location with clean fresh air. Drink water and blow nose. Seek immediate medical attention if symptoms persist.

# 12 Maintenance and Service Instructions

## A. MAINTENANCE OF LOW WATER CUT-OFF DEVICES

### WARNING

Probe and float type low water cut-off devices require annual inspection and maintenance.

#### 1. PROBE TYPE LOW WATER CUT-OFF

Although these devices are solid state in their operation, the probe is exposed to possible contamination in the boiler water and subject to fouling.

It is important to physically remove the probe from the boiler tapping annually and inspect that probe for accumulation of scale or sediment.

Follow these steps to inspect, clean and/or replace the probe:

- a. Turn off electric service to the boiler.
- b. Drain boiler water to a level below the tapping for the probe.
- c. Disconnect wiring connections between the low water cut-off control and the probe.
- d. Remove the low water cut-off control from the probe.

### DANGER

Assure that the boiler is at zero pressure before removing the LWCO probe. **DO NOT** rely on the pressure gauge to indicate that the boiler is at zero pressure. Open the safety valve to relieve all internal pressure prior to proceeding. Safety valve discharge piping must be piped such that the potential for burns is eliminated.

- e. Unscrew the probe from the boiler tapping.
- f. Inspect that portion of the probe that is exposed to the boiler water for a scale or sediment buildup.
- g. Light deposits may be removed by wiping the probe with a damp cloth. Wiping the probe with a cloth soaked in vinegar will remove more tenacious lime deposits. The most stubborn deposits may be removed from the probe by using a diluted amount, 3 parts of water to 1 part of phosphoric acid ( $H_2PO_4$ ).

### CAUTION

Exercise caution when handling phosphoric acid and follow the instruction label on its container.

- h. Clean the pipe threads of the probe to remove old, hardened pipe dope and other foreign matter.

- i. Apply a moderate amount of good quality pipe dope to the pipe threads on the probe, leaving the two end threads bare. **DO NOT** use PTFE (Teflon) tape.
- j. Screw the probe into the boiler tapping.
- k. Mount the low water cut-off control on the probe.
- l. Reconnect the control to probe wiring.
- m. Fill the boiler to its normal waterline.
- n. Add boiler water treatment compound as needed (refer to Paragraph B.).
- o. Restore electric service to the boiler.
- p. Fire burner to bring the water in the boiler to a boil to drive off free oxygen.
- q. **WARNING — BEFORE RETURNING BOILER TO SERVICE:** Follow the low water cut-off check out procedure in Section 10, Paragraph I, No. 4.

## B. BOILER AND SYSTEM CLEANING INSTRUCTIONS FOR TROUBLE FREE OPERATION

**NOTICE:** Check with local authorities or consult local water treatment services for acceptable chemical cleaning compounds.

### 1. WATER BOILERS

- a. *Filling of Boiler and System — General*—In a hot water heating system, the boiler and entire system (other than the expansion tank) must be full of water for satisfactory operation. Water should be added to the system until the boiler pressure gauge registers 12 psi. To insure that the system is full, water should come out of all air vents when opened.
- b. *Boiling Out of Boiler and System.* The oil and grease which accumulate in a new hot water boiler can be washed out in the following manner.
  - i. Remove relief valve using extreme care to avoid damaging it.
  - ii. Add an appropriate amount of recommended boil out compound.
  - iii. Replace relief valve.
  - iv. Fill the entire system with water.
  - v. Start firing the boiler.
  - vi. Circulate the water through the entire system.
  - vii. Vent the system, including the radiation.
  - viii. Allow boiler water to reach operating temperature, if possible.

## 12 Maintenance and Service Instructions *(continued)*

- ix. Continue to circulate the water for a few hours.
  - x. Stop firing the boiler.
  - xi. Drain the system in a manner and to a location that hot water can be discharged with safety.
  - xii. Remove plugs from all available returns and wash the water side of the boiler as thoroughly as possible, using a high-pressure water stream.
  - xiii. Refill the system with fresh water.
- c. Add appropriate boiler water treatment compounds as recommended by your qualified water treatment company.
- d. *Make pH or Alkalinity Test.*

After boiler and system have been cleaned and refilled as previously described, test the pH of the water in the system. This can easily be done by drawing a small sample of boiler water and testing with hydriion paper which is used in the same manner as litmus paper, except it gives specific readings. A color chart on the side of the small hydriion dispenser gives the reading pH. Hydriion paper is inexpensive and obtainable from any chemical supply house or through your local druggist. The pH should be higher than 7 but lower than 11. Add appropriate water treatment chemicals, if necessary, to bring the pH within the specified range. With this lower level of protection, care must be exercised to eliminate all of the free oxygen in the system.

- e. Boiler is now ready to be put into service.

### C. EXCESSIVE MAKE-UP WATER

#### IMPORTANT

**IF, DURING NORMAL OPERATION, IT IS NECESSARY TO ADD MORE WATER THAN INDICATED BELOW, CONSULT A QUALIFIED SERVICE TECHNICIAN TO CHECK YOUR SYSTEM FOR LEAKS.**

Boiler Series	Gallons Per Month	Gallons Per Year
V8H3	0.3	3
V8H4	0.4	5
V8H5	0.5	6
V8H6	0.6	7
V8H7	0.7	8

A leaky system will increase the volume of make-up water supplied to the boiler which can significantly shorten the life of the boiler. Entrained in make-up water are dissolved minerals, salts and oxygen. When the fresh, cool make-up water is heated in the boiler the minerals fall out as sediment, the salts coat the inside of the boiler, and the oxygen escapes as a gas. The accumulation of sediment eventually isolates the water from contacting the cast iron. When this happens the cast iron in that area gets extremely hot and eventually cracks. The presence of free oxygen or chloride salts in the boiler corrodes the cast iron from the inside. More make-up water and higher concentrations of contaminants damage the boiler sooner. **Our warranty does not cover corrosion and sediment-related damage.** Clearly it is in everyone's best interest to prevent this type of failure. You can do your part by ensuring that your system is leak-free, keeping leakage to less than 2 percent of the boiler water volume each month.

### D. ATTENTION TO BOILER WHILE NOT IN OPERATION

**NOTICE:** If boiler is not used during winter time, it must be fully drained to prevent freeze damage.

1. Spray inside surfaces with light lubricating or crankcase oil using gun with extended stem so as to reach all corners.
2. Always keep the manual fuel supply valve shut off if the burner is shut down for an extended period of time.
3. To recondition the heating system in the fall season after a prolonged shut down, follow the instructions outlined in Section 10, Paragraphs A through K.

#### WARNING

This boiler contains controls which may cause the boiler to shut down and not restart without service. If damage due to frozen pipes is a possibility, the heating system should not be left unattended in cold weather; or appropriate safeguards and alarms should be installed on the heating system to prevent damage if the boiler is inoperative.

# 13 Boiler Cleaning

## WARNING

All boiler cleaning must be completed with burner service switch turned off. Boilers equipped with burner swing door have a potential hazard which can cause severe property damage, personal injury or loss of life if ignored. Before opening swing door, turn off service switch to boiler to prevent accidental firing of burner outside the combustion chamber. Be sure to tighten swing door fastener completely when service is completed.

### A. CLEAN THE FLUEWAYS (See Figure 13-1).

1. For access to combustion chamber remove two (2) 5/16 in. - 18 cap screws, one on the right (1¼ in. long) and one on the left (3¼ in. long). If boiler is equipped with flexible fuel line(s), swing door open.
2. For cleaning from the side:
  - a. Remove the jacket right side access panel to expose the flue cover plates.
  - b. Loosen nuts securing the flue cover plates and remove the plates. The rope gasket should be removed with the plates with care to avoid damage to the rope gasket.
3. For cleaning from the top:
  - a. Remove as much vent pipe as necessary to allow removal of the jacket top panel and canopy.
  - b. Remove the jacket top panel.
  - c. Remove flue baffles.
  - d. Remove the canopy, being careful not to damage the gasket.
4. Using a 1¼ in. diameter wire or fibre bristle brush (30 in. handle) clean the flueways. Brush from the top and/or side using horizontal and diagonal strokes for best results. **DO NOT** allow brush to strike the target wall or liner in the chamber.

### B. CLEAN TOP OF BOILER SECTIONS

(if cleaning from the top).

Brush and vacuum the tops of the boiler sections.

### C. CLEAN THE COMBUSTION CHAMBER

Using wire or fibre bristle brush, clean crown of boiler and inside of water legs.

## WARNING

**DO NOT** allow brush to strike target wall in the combustion chamber.

- ### D. AFTER CLEANING
- Inspect target wall, burner swing door insulation, and rope gasket for signs of damage. If damaged, replace as needed.

### E. REASSEMBLE BOILER

## CAUTION

**DO NOT** start the burner unless canopy, vent pipe, burner swing door and all flue cover plates are secured in place.

1. Insert the flue baffles.
2. Install the canopy taking care to align the gasket without blocking the flueways. If gasket is damaged, replace as needed.
3. Reinstall flue cover plates, making sure rope gasket on each plate is in place and forms a gas tight seal. If damaged replace as needed.
4. Reinstall jacket top panel and/or jacket upper right side access panel with #8 x ½ in. long sheet metal screws.
5. Reinstall vent pipe on canopy and secure to collar with sheet metal screws.
6. Close burner swing door. Secure door to front section with 5/16 in. flange nut and washer (right side) and 5/16 in. x 3½ in. lg. bolt (left side).

**NOTICE:** When securing burner swing door make sure door is drawn-in equally on both sides.

Tighten swing door hardware to provide adequate seal to rope gasket around perimeter of door.

Use an alternating tightening method from right side flange nut to left side cap screw to pull door tight equally.

## 13 Boiler Cleaning *(continued)*

### NOTES:

1. PRIOR TO CLEANING BOILER, LAY A PROTECTIVE CLOTH OR PLASTIC OVER THE BLANKET TO COLLECT DEBRIS FALLING FROM FLUEWAYS.
2. AFTER CLEANING, INSPECT TARGET WALL, COMBUSTION CHAMBER BLANKET, BURNER SWING DOOR INSULATION AND ROPE GASKET FOR SIGNS OF DAMAGE. IF DAMAGED, REPLACE AS NEEDED.
3. REPLACE CANOPY GASKET STRIPS AS NEEDED IF DAMAGED.

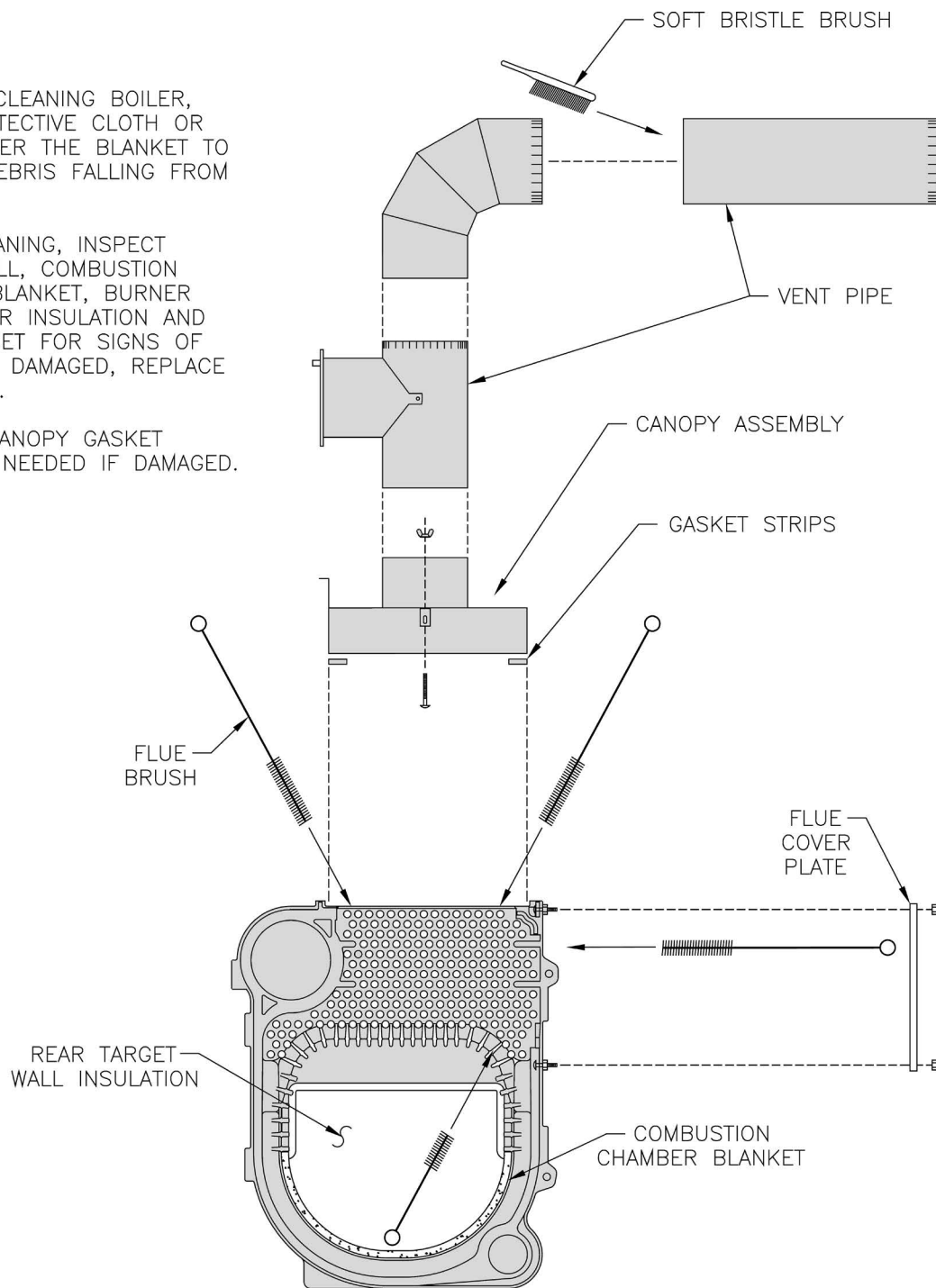

**Figure 13-1: Cleaning of Boiler Flueways**

### **⚠ WARNING**

The boiler must be connected to an approved chimney in good condition. Serious property damage could result if the boiler is connected to a dirty or inadequate chimney. The interior of the chimney flue must be inspected and cleaned before the start of the heating season and should be inspected periodically throughout the heating season for any obstructions. A clean and unobstructed chimney flue is necessary to allow noxious fumes that could cause injury or loss of life to vent safely and will contribute toward maintaining the boiler's efficiency.

# 14 Troubleshooting

## A. COMBUSTION

1. **NOZZLES** — Although the nozzle is a relatively inexpensive device, its function is critical to the successful operation of the oil burner. The selection of the nozzle supplied with the V8H boiler is the result of extensive testing to obtain the best flame shape and efficient combustion. Other brands of the same spray angle and spray pattern may be used but may not perform at the expected level of CO<sub>2</sub> and smoke. Nozzles are delicate and should be protected from dirt and abuse. Nozzles are mass-produced and can vary from sample to sample. For all of those reasons a spare nozzle is a desirable item for a serviceman to have.
2. **FUEL LEAKS** — Any fuel leak between the pump and the nozzle will be detrimental to good combustion results. Look for wet surfaces in the air tube, under the ignitor, and around the air inlet. Any such leaks should be repaired as they may cause erratic burning of the fuel and in the extreme case may become a fire hazard.
3. **SUCTION LINE LEAKS** — Any such leaks should be repaired, as they may cause erratic burning of the fuel and in extreme cases may become a fire hazard. Whatever it takes, The Oil Must Be Free of Air. This can be a tough problem, but it must be resolved. Try bleeding the pump through a clear tube. There must be no froth visible. There are various test kits available to enable you to look at the oil through clear tubing adapted to the supply line at the pump fitting. Air eliminators are on the market that have potential. Also, electronic sight glasses are being used with good success. At times, new tubing must be run to the tank or new fittings put on. Just make sure you get the air out before you leave. Any air leaks in the fuel line will cause an unstable flame and may cause delayed ignition noises. Use only flare fittings in the fuel lines.
4. **GASKET LEAKS** — If 11.5 to 13.0% CO<sub>2</sub> with a #1 smoke cannot be obtained in the breeching, look for air leaks around the burner mounting gasket, observation door, and canopy gasket. Such air leaks will cause a lower CO<sub>2</sub> reading in the breeching. The smaller the firing rate the greater effect an air leak can have on CO<sub>2</sub> readings.
5. **DIRT** — A fuel filter is a good investment. Accidental accumulation of dirt in the fuel system can clog the nozzle or nozzle strainer and produce a poor spray pattern from the nozzle. The smaller the firing rate, the smaller the slots become in the nozzle and the more prone to plugging it becomes with the same amount of dirt.
6. **WATER** — Water in the fuel in large amounts will stall the fuel pump. Water in the fuel in smaller amounts will cause excessive wear on the pump, but more importantly water doesn't burn. It chills the flame and causes smoke and unburned fuel to pass out of the combustion chamber and clog the flueways of the boiler.
7. **COLD OIL** — If the oil temperature approaching the fuel pump is 40°F or lower, poor combustion or delayed ignition may result. Cold oil is harder to atomize at the nozzle. Thus, the spray droplets get larger and the flame shape gets longer. An outside fuel tank that is above grade or has fuel lines in a shallow bury is a good candidate for cold oil. The best solution is to locate the tank near the boiler in the basement utility room or bury the tank and lines deep enough to keep the oil above 40°F. Check environmental issues with local authorities having jurisdiction.
8. **FLAME SHAPE** — Looking into the combustion chamber through the observation port, the flame should appear straight with no sparklers rolling up toward the crown of the chamber. If the flame drags to the right or left, sends sparklers upward or makes wet spots on the target wall, the nozzle should be replaced. If the condition persists look for fuel leaks, air leaks, water or dirt in the fuel as described above.
9. **HIGH ALTITUDE INSTALLATIONS** — Air openings must be increased at higher altitudes. Use instruments and set for 11.5 to 13.0% CO<sub>2</sub>.
10. **START-UP NOISE** — Late ignition is the cause of start-up noises. If it occurs recheck for electrode settings, flame shape, air or water in the fuel lines.
11. **SHUT DOWN NOISE** — If the flame runs out of air before it runs out of fuel, an after burn with noise may occur. That may be the result of a faulty cut-off valve in the fuel pump, or it may be air trapped in the nozzle line. It may take several firing cycles for that air to be fully vented through the nozzle. Water in the fuel or poor flame shape can also cause shut down noises.

# 14 Troubleshooting *(continued)*

**NOTICE:** CHECK TEST PROCEDURE. A very good test for isolating fuel side problems is to disconnect the fuel system and with a 24 in. length of tubing, fire out of an auxiliary five gallon pail of clean, fresh, warm #2 oil from another source. If the burner runs successfully when drawing out of the auxiliary pail then the problem is isolated to the fuel or fuel lines being used on the jobsite.

## B. OIL PRIMARY CONTROL (Oil Primary)

1. Burner (Oil Primary) will not come on.
  - a. No power to Oil Primary.
  - b. Oil Primary is in lockout or restricted mode. Press reset button for one (1) second to exit lockout. If control has recycled three times within the same call for heat, it will enter into restricted mode. To reset from restricted mode, refer to Section 11, Paragraph I, No. 2 for details.
  - c. CAD cell seeing light.
  - d. CAD assembly defective.
  - e. Control motor relay is stuck closed (see note below).
2. Burner (control) will light, then shut down after a short time, then restart after one (1) minute.
  - a. CAD cell is defective.
  - b. Air leaking into oil line causing flame out.
  - c. Defective nozzle causing flame to be erratic.
  - d. Excessive airflow or draft causing flame to leave burner head.
  - e. Excessive back pressure causing flame to be erratic.

3. Control locks out after Trial For Ignition (TFI).
  - a. No oil to burner.
  - b. Shorted electrodes.
  - c. Nozzle clogged.
  - d. Airflow too high.
  - e. Ignitor module defective.
  - f. CAD cell defective.
  - g. Oil valve stuck open or closed.

Note: The Safety Monitoring Circuit (SMC) is designed to provide lockout in the event of a stuck or welded motor relay.

**NOTICE:** If flame is not established within 15 seconds of oil valve actuation (known as Trial For Ignition [TFI]) lockout will occur. Lockout is indicated by a red LED solid-on located on the oil primary control. Hard Lockout will occur if the Oil Primary Control locks-out three (3) times during a call for heat. This is indicated by red light reset button solid-on.

## C. INTELLIGENT OIL BOILER CONTROL

- **Cold Start Boiler Control** is used on Boilers without Tankless Heaters.
  - **Warm Start Boiler Control** is used on Boilers with Tankless Heaters.
1. When a problem occurs with the boiler operation, the Boiler Control easily provides specific, valuable information to help resolve the issue quickly. The display on the Boiler Control should be the first place to check.

**Table 14-1: Troubleshooting Guide**

System Condition	Diagnostic Condition	Check	Action
Boiler is cold, house is cold.	Display is OFF.	120 VAC System power.	Turn system power on.
	Display is ON.	24 VAC T-T	No 24 V; replace control.
		24 V present; disconnect thermostat, short T-T.	Boiler starts, check wiring and thermostat.
		120 VAC at B1-B2	<ul style="list-style-type: none"> <li>• If no, replace control.</li> <li>• If yes, check burner and wiring.</li> </ul>
	Refer to <b>Err</b> on display.		-----
Boiler is hot, house is cold.	Display is ON.	120 VAC at C1-C2	<ul style="list-style-type: none"> <li>• 120 VAC at C1-C2, check wiring to pump.</li> <li>• Wiring OK, is pump running?</li> <li>• If not, replace the pump.</li> <li>• If pump is running, check for trapped air or closed zone valves</li> </ul>
		Boiler below the Low Limit temperature, wait for boiler to go above Low Limit temperature.	-----
		Boiler above LL? If yes, check for 120 VAC between ZC and L2.	<ul style="list-style-type: none"> <li>• If no 120 VAC, replace control.</li> <li>• If yes, check zone relays, circulators and wiring.</li> </ul>

## 14 Troubleshooting *(continued)*

- a. If an Error Code "Err" **IS NOT** displayed on the Boiler Control: In this circumstance, Table 14-1 can be used to determine the problem and possible causes.
- b. If the Boiler Control detects an error it will flash "Err" (boiler control error) followed by a number. Use this text and number to identify the boiler problem and corrective action in Table 14-2 below.

**Table 14-2: Boiler control error numbers**

Display	Status	Recommended Corrective Actions
Err 1	Temperature Sensor Fault	Temperature sensor failure, wire harness loose or shorted connection or control hardware failure: <ul style="list-style-type: none"> <li>- Check sensor is securely attached to boiler control</li> <li>- Check that sensor wire is not damaged</li> <li>- If secure and in good condition, replace sensor</li> <li>- If problem persists, replace control</li> </ul>
Err 2	Communication Fault	EnviraCom terminal is shorted to ground or line voltage. <ul style="list-style-type: none"> <li>- Check wiring to EnviraCOM terminals 1,2 and 3. Wiring to external EnviraCom device is incorrect.</li> </ul>
Err 3	Internal Hardware Fault	Error detected with AC power supply frequency or boiler control failure. Cycle power to the control. Replace control if problem persists.
Err 4	Burner Output (B1) Fault	B1 output sensed powered during safety output relay check sequence or un-powered during running, or powered in idle in combination with water temperature above 264°F limit. Cycle power to the control. Replace control if problem persists.
Err 5	Line Voltage Fault (< 80 VAC)	AC voltage out of specification high or low; check L1, L2, 110 VAC.
Err 6	Fuse missing	Internal fuse is blown or missing. The fuse protects the Aquastat from miswiring the L1 and L2 on Oil Primary. When the Oil Primary is correctly wired the fuse is useless and not detected. If Primary is wired incorrectly the fuse is blown out and Aquastat report error 6. EnviraCOM message is sent when the wiring is fixed and the error disappears to indicate the end of the error state. Check wiring and replace fuse.
Err 7	User settings lost, (reset to factory defaults)	Warning: Generated if user adjustments are lost and the device uses factory default values. Error is cleared by entering and exiting the Adjustment mode. Replace control if problem persists.
Err 8	Manual Reset Lockout (reset table)	Set if Err 4 was invoked four times in a row. Check wiring and clear Lockout by pressing all three user keys for 30 seconds.

**Page Intentionally Left Blank**

## 15 Service Parts

All V8H™ Series Boiler Service Parts may be obtained through your local U.S. Boiler Company Wholesale distributor. Should you require assistance in locating a U.S. Boiler Company Distributor in your area, or have questions regarding the availability of U.S. Boiler Company products or service parts, please contact U.S. Boiler Company Customer Service at (717) 481-8400 or Fax (717) 481-8408.

# 15 Service Parts *(continued)*

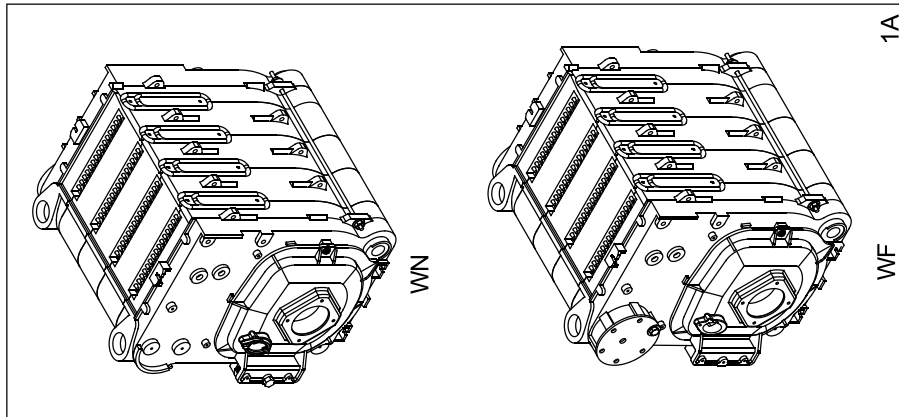
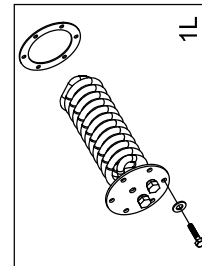
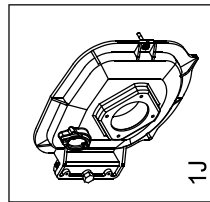
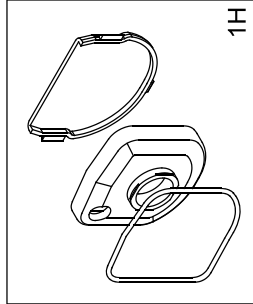
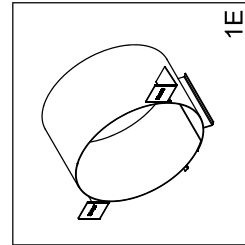
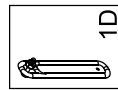
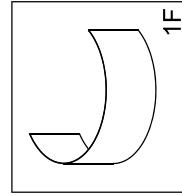
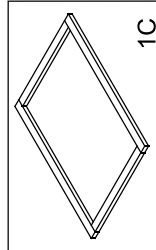
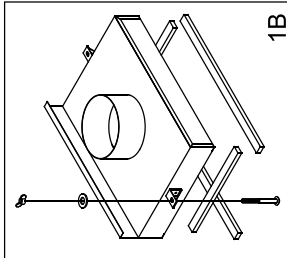
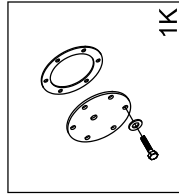
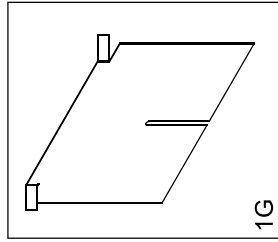

Bare Boiler Assembly

# 15 Service Parts *(continued)*

Item No.	Description	Part Number	V8H3WE	V8H4WE	V8H5WE	V8H6WE	V8H7WE	
1A	WF: Block Assembly Carton for Water, Front Heater Opening Includes: Complete Block Assembly, Target Wall Insulation, Flue Cover Plates, Coil Gasket, Coil Cover Plate/ Hardware	101349-03	1					
		101349-04		1				
		101349-05			1			
		101349-06				1		
		610280711					1	
	WN: Block Assembly for Water, Non-Heater Includes: Complete Block Assembly, Target Wall Insulation, Flue Cover Plates	101362-03	1					
		101362-04		1				
		101362-05			1			
		101362-06				1		
		610280701					1	
1B	Canopy Includes: Canopy, Canopy Gasket,, and Hardware	611280321	1					
		611280421		1				
		611280521			1			
		611280621				1		
		611280721					1	
1C	Canopy Gasket	110272-01	1	1	1	1	1	
1D	Flue Cover Plate	110273-01	2	3	4	5	6	
1E	Combustion Chamber Ring	111778-01	1					
1F	Combustion Chamber Plate	110275-01			1			
1G	Flue Baffles	110276-01	2	3	4	5	6	
1H	Combustion Chamber Includes: Target Wall Insulation, Combustion Chamber Blanket, Burner Door Insulation, and Burner Door Rope Gasket	108136-01	1	1	1	1	1	
1J	Burner Swing Door Includes: Burner Swing Door, Burner Door Insulation, Burner Door Rope Gasket, Hinge, Observation Port Cover, and Hardware	110282-01	1	1	1	1	1	
1K	Heater Cover Plates & Gaskets	Front Heater-Blank	110048-01	1	1	1	1	1
		Front Heater-Trapped		1	1	1	1	1
1L	222B Coil	104939-01	1	1	1	1	1	

# 15 Repair Parts *(continued)*

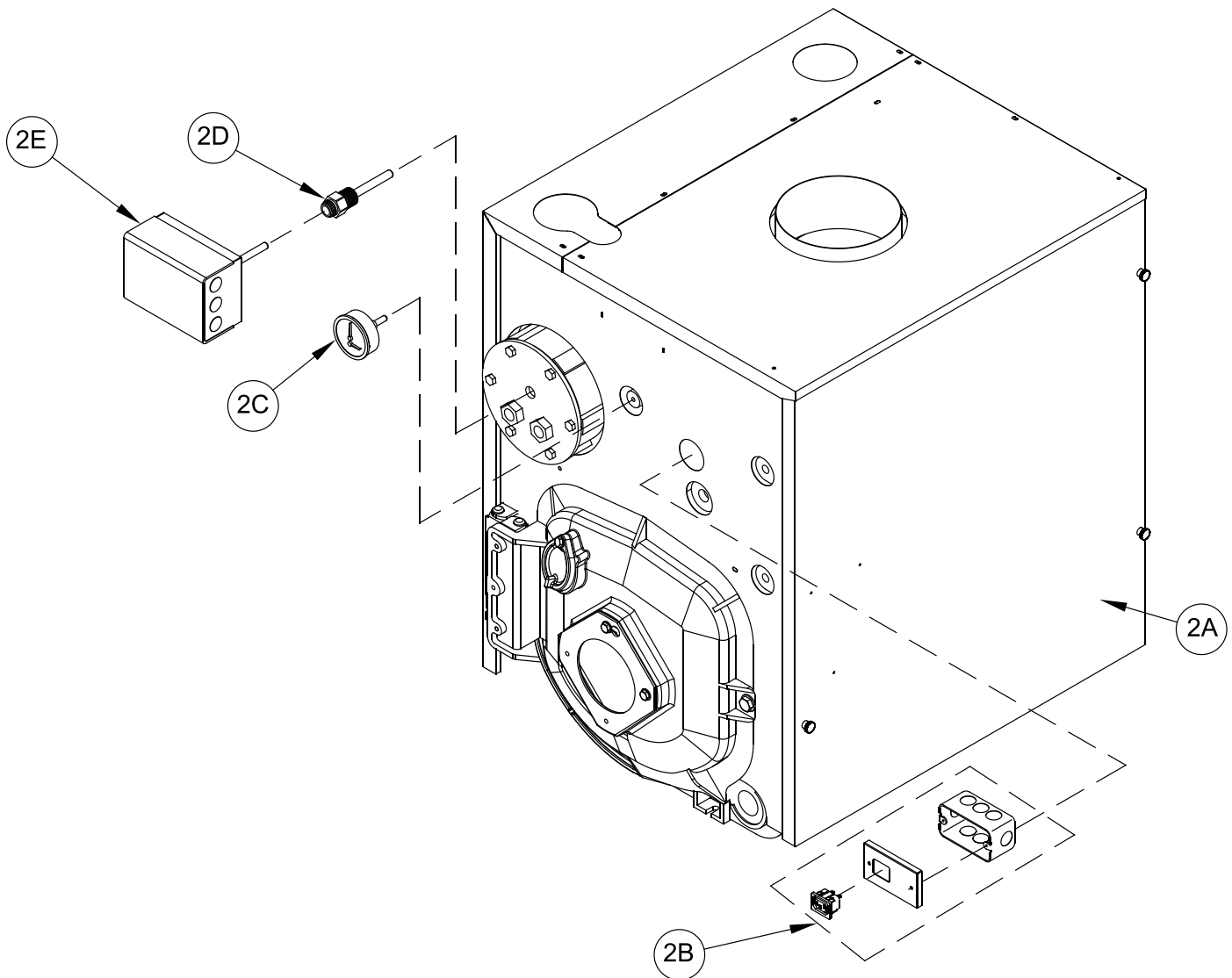

**Water Boilers - Trim and Controls**

# 15 Repair Parts *(continued)*

Item No.	Description		Part Number	V8H3WE	V8H4WE	V8H5WE	V8H6WE	V8H7WE	
2A	WF: Complete Jacket Carton for Water, Front Heater		110270-03	1					
			110270-04		1				
			110270-05			1			
			110270-06				1		
			110270-07					1	
	WN: Complete Jacket Carton for Water, Non-Heater		110271-03	1					
			110271-04		1				
			110271-05			1			
			110271-06				1		
			110271-07					1	
2B	Burner Disconnect J-Box Includes: J-Box and Burner Receptacle		110277-01	1	1	1	1	1	
2C	Temperature & Pressure Gauge, 1/4 in. NPT x 2-1/2 in. Dia., 1-1/2 in.		105894-01	1	1	1	1	1	
2D	Honeywell #123870A Immersion Well, 3/4 in. NPT x 1-1/2 in. Insulation (WN)		109744-01	1	1	1	1	1	
	Honeywell #123872A Immersion Well, 1/2 in. NPT x 3 in. Insulation (WF)		109711-01	1	1	1	1	1	
	Electro-Well (WN)		110278-01	1	1	1	1	1	
	Electro-Well (WF)		110279-01	1	1	1	1	1	
2E	Honeywell L7248L1080 (WN) Assembly Includes: Control and Harness		110281-01	1	1	1	1	1	
	Honeywell L7224C1010 (WF) Assembly Includes: Control and Harness		110280-01	1	1	1	1	1	
	HydroStat 3250 Plus (WN) Assembly Includes: Control and Harness		110284-01	1	1	1	1	1	
	HydroStat 3250 Plus (WF) Assembly Includes: Control and Harness		110283-01	1	1	1	1		
	Harness		110285-01	1	1	1	1	1	
Not Shown	Relief Valve, Conbraco, 3/4 in. FIP x 3/4 in.	#10-408-05	30 PSI	Obtain Locally	1	1	1	1	1
		#10-303-07	40 PSI						
		#10-303-10	50 PSI						
	6 in. Draft Regulator				1	1	1	1	
	7 in. Draft Regulator								1
	Drain Valve, 3/4 in. NPT, ConBraCo 35-302-03				1	1	1	1	1
	Circulator Flange, 1-1/2 in. NPT				2	2	2	2	2
	Circulator Gasket	Taco #194-1548			2	2	2	2	2
		Grundfos							
	Circulator	Taco 007e			1	1	1	1	1
Grundfos Alpha2									

# 15 Service Parts *(continued)*

Item No.	Description	Part Number	V8H3WE	V8H4WE	V8H5WE	V8H6WE	V8H7WE	
Not Shown	Beckett	110222-03	1					
		110223-04		1				
		110224-05			1			
		110225-06				1		
		102114-07					1	
	Carlin	101292-01	1					
		101293-01		1				
		101294-01			1			
		101295-01				1		
		101296-01					1	
	Riello	101307-01	1					
		101308-01		1				
		101309-01			1			
		101310-01				1		
		101311-01					1	
	Primary Control	Honeywell R7284P1080	103880-01	1	1	1	1	1
		Beckett GeniSys 7505P1515	Obtain Locally	1	1	1	1	1
		Carlin		1	1	1	1	1
		Reillo	Contact Burner Manufacturer	1	1	1	1	1
	Burner Disconnect Harness		102115-01	1	1	1	1	1

# 16 Burner Specifications

**Table 16-1: Burner Specifications**

Boiler Model	Firing Rate GPH	Beckett AFG					Carlin				
		Settings			<sup>1</sup> Nozzle	<sup>2</sup> Pump Pressure	Burner Model	Settings		<sup>1</sup> Nozzle	<sup>2</sup> Pump Pressure
		Head (Setting)	Air Shutter	Air Band	GPH x Angle Type			Head Bar	Air Band	GPH x Angle Type	
V8H3WE	1.00	L1	7	1	0.85 x 60A	140	EZ-1HP	0.85/1.00	0.70	0.85 x 70B	150
V8H4WE	1.25	V1 (0)	10	2	1.10 x 60B Hago	140		1.10/1.25	0.85	1.10 x 60B	150
V8H5WE	1.65	V1 (2)	10	5	1.35 x 60B	140		1.35/1.50	1.35	1.35 x 60B	150
V8H6WE	1.90	V1 (3)	10	3.5	1.50 x 45B	160	EZ-66	5	100%	1.65 x 60B	140
V8H7WE	2.10	V1 (4)	10	3	1.65 x 45B HAGO	170	102CRD-3	3	50%	1.75 x 60B	140

<sup>1</sup> All burners utilize Delavan nozzles unless otherwise noted.

<sup>2</sup> Single stage fuel pump is standard, two stage fuel pump is optional. Burner manufacturer has preset single stage fuel pump to settings shown in table above.

Two stage fuel pump is factory set at 140 PSI and must be readjusted to settings shown above during burner start-up.

Boiler Model	Firing Rate GPH	Riello				
		Burner Model	Settings		<sup>1</sup> Nozzle	Pump Pressure
			Air Gate	Turbulator	GPH x Angle Type	
V8H3WE	1.00	40-F5	2.8	1.0	0.90 x 80B	145
V8H4WE	1.20	40-F5	3.3	3.0	1.20 x 80B	145
V8H5WE	1.65	40-F5	5.2	4.0	1.35 x 70B	145
V8H6WE	1.90	40-F10	3.7	2.0	1.65 x 60B	145
V8H7WE	2.10	40-F10	4.0	4.0	2.00 x 45B	145

<sup>1</sup> All burners utilize Delavan nozzles unless otherwise noted.

<sup>2</sup> Single stage fuel pump is standard, two stage fuel pump is optional. Burner manufacturer has preset single stage fuel pump to settings shown in table above.

Two stage fuel pump is factory set at 140 PSI and must be readjusted to settings shown above during burner start-up.

## Appendix - Aftermarket Low Water Cut Off (LWCO)

### ⚠ WARNING

DO NOT ATTEMPT to cut factory wires to install an aftermarket Low Water Cut Off (LWCO). Only use connections specifically identified for Low Water Cut Off.

In all cases, follow the Low Water Cut Off (LWCO) manufacturer's instructions.

#### When

A low water cutoff is required to protect a hot water boiler when any connected heat distributor (radiation) is installed below the top of the hot water boiler (i.e. baseboard on the same floor level as the boiler). In addition, some jurisdictions require the use of a LWCO with a hot water boiler.

#### Where

The universal location for a LWCO on oil hot water boilers is above the boiler, in either the supply or return piping. The minimum safe water level of a water boiler is at the uppermost top of the boiler; that is, it must be full of water to operate safely.

It is recommended that the LWCO control is installed above the boiler to provide the highest level of protection. However, where the LWCO control is approved by the LWCO control manufacturer for installation in a high boiler tapping of a water boiler, the use of the listed LWCO control is permitted when it is installed according to the LWCO manufacturer's instructions.

#### What Kind

Typically, in residential applications, a probe type LWCO is used instead of a float type, due to their relative costs and the simplicity of piping for a probe LWCO.

#### How to Pipe

A "tee" is commonly used to connect the probe LWCO in the supply or return piping, as shown below.

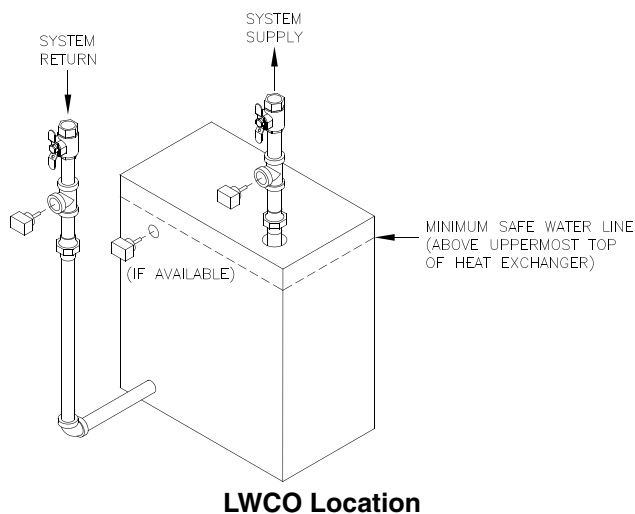

Select the appropriate size tee using the LWCO manufacturer's instructions. Often, the branch connection must have a **minimum** diameter to prevent bridging between the probe and the tee. Also, the run of the tee must have a minimum diameter to prevent the end of the probe from touching or being located too close to the inside wall of the run of the tee.

Ideally, manual shutoff valves should be located above the LWCO and the boiler to allow for servicing. This will allow probe removal for inspection without draining the heating system. Many probe LWCO manufacturers recommend an annual inspection of the probe.

#### How to Wire

LWCO's are available in either 120 VAC or 24 VAC configurations. The 120 VAC configuration must be applied to oil boilers by wiring it in the line voltage service to the boiler (after the service switch, if so equipped).

The presence of water in a properly installed LWCO will cause the normally open contact of the LWCO to close, thus providing continuity of the 120 VAC service to the boiler.

It is recommended to supply power to the probe LWCO with the same line voltage servicing the boiler as shown below.

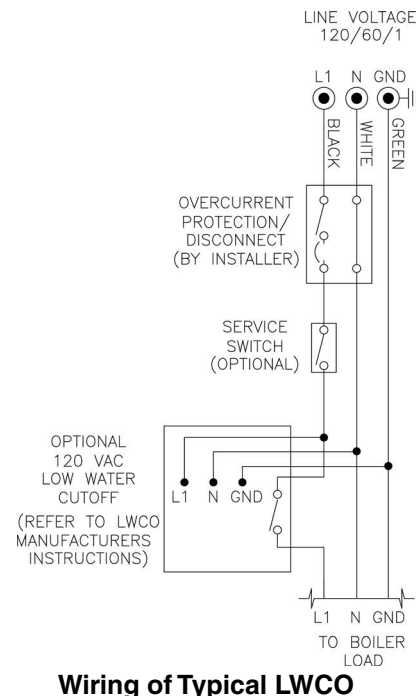

## Appendix - Aftermarket Low Water Cut Off (LWCO)

A 24 VAC LWCO is used primarily for gas fired boilers where a 24 volt control circuit exists within the boiler. However, a 24 VAC LWCO can only be used if the boiler manufacturer has provided piping and wiring connections and instructions to allow for this application.

### How to Test

Shut off fuel supply. Lower water level until water level is BELOW the LWCO. Generate a boiler demand by turning up thermostat. Boiler should not attempt to operate. Increase the water level by filling the system. The boiler should attempt to operate once the water level is above the LWCO.

**U.S. Boiler Company, LLC**  
**P.O. Box 3020**  
**Lancaster, PA 17604**  
**1-888-432-8887**  
[www.usboiler.net](http://www.usboiler.net)