

EMP

Models:

- EMP84E
- EMP115E
- EMP140E
- EMP182E
- EMP224E
- EMP280E
- EMP336E

- High Efficiency
- Oil-Fired, 3-Pass
- Water Boiler
- Natural Draft or Direct Vent (140E thru 224E)
- B20 Ready

Manual Contents

	<u>Page</u>
1. Pre-installation	7
2. Packaged Boiler Assy. - Trim	10
3. Water Boiler Piping	19
4. Natural Draft Venting	22
5. Direct Venting / Air Intake Piping	26
6. Electrical	33
7. Oil Piping	36
8. System Start-Up	38
9. Operation	44
10. Maintenance and Service Instructions	51
11. Boiler Cleaning	53
12. Troubleshooting	55
13. Service Parts	60
14. Burner Specifications	66

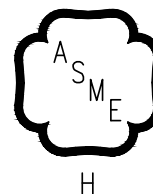

As an ENERGY STAR® Partner, U.S. Boiler Company has determined that the EMP84E thru EMP224E meet the ENERGY STAR® guidelines for energy efficiency established by the United States Environmental Protection Agency (EPA).



TO THE INSTALLER:

Affix these instructions adjacent to boiler.

TO THE CONSUMER:

Retain these instructions for future reference.



IMPORTANT INFORMATION - READ CAREFULLY

All boilers must be installed in accordance with National, State and Local Plumbing, Heating and Electrical Codes and the regulations of the serving utilities. These Codes and Regulations may differ from this instruction manual. Authorities having jurisdiction should be consulted before installations are made.

In all cases, reference should be made to the following Standards:

USA BOILERS

- A. Current Edition of American National Standard ANSI/NFPA 31, "Installation of Oil Burning Equipment"; for recommended installation practices.
- B. Current Edition of American National Standard ANSI/NFPA 211, "Chimneys, Fire places, Vents, and Solid Fuel Burning Appliances"; For Venting requirements.
- C. Current Edition of American Society of Mechanical Engineers ASME CSD-1, "Controls and Safety Devices for Automatically Fired Boilers"; for assembly and operations of controls and safety devices.
- D. All wiring on boilers installed in the USA shall be made in accordance with the National Electrical Code and/or Local Regulations.

IMPORTANT

This boiler is equipped with a feature that saves energy by reducing the boiler water temperature as the heating load decreases. This feature is equipped with an override which is provided primarily to prevent the use of an external energy management system that serves the same function. THIS OVERRIDE MUST NOT BE USED UNLESS AT LEAST ONE OF THE FOLLOWING CONDITIONS IS TRUE:

- An external energy management system is installed that reduces the boiler water temperature as the heating load decreases.
- This boiler is not used for any space heating.
- This boiler is part of a modular or multiple boiler system having a total input of 300,000 BTU/HR or greater.
- This boiler is equipped with a tankless coil.

The following terms are used throughout this manual to bring attention to the presence of hazards of various risk levels, or to important information concerning product life.

DANGER

Indicates an imminently hazardous situation which, if not avoided, will result in death, serious injury or substantial property damage.

CAUTION

Indicates a potentially hazardous situation which, if not avoided, may result in moderate or minor injury or property damage.

WARNING

Indicates a potentially hazardous situation which, if not avoided, may result in moderate or minor injury or property damage.

NOTICE: Indicates special instructions on installation, operation, or maintenance which are important but not related to personal injury hazards.

NOTICE: This boiler has a limited warranty, a copy of which is included with this boiler. The warranty for this boiler is valid only if the boiler has been installed, maintained and operated in accordance with these instructions.

Surface rust on cast iron sections may be attributed to the manufacturing process as well as condensation during storage. Surface rust is normal and does not affect the performance or longevity of a boiler.

 **DANGER**

DO NOT store or use gasoline or other flammable vapors or liquids in the vicinity of this or any other appliance.

 **WARNING**

Improper installation, adjustment, alteration, service or maintenance can cause property damage, personal injury or loss of life. Failure to follow all instructions in the proper order can cause personal injury or death. Read and understand all instructions, including all those contained in component manufacturers manuals which are provided with the boiler before installing, starting-up, operating, maintaining or servicing this boiler. Keep this manual and literature in legible condition and posted near boiler for reference by owner and service technician.

- This boiler requires regular maintenance and service to operate safely. Follow the instructions contained in this manual.
- Installation, maintenance, and service must be performed only by an experienced, skilled and knowledgeable installer or service agency.
- All heating systems should be designed by competent contractors and only persons knowledgeable in the layout and installation of hydronic heating systems should attempt installation of any boiler.
- Installation is NOT complete unless a pressure relief valve is installed into the tapping located on top of Shell Assembly in the front left corner - See Water Piping and Trim Section of this manual for additional details.
- It is the responsibility of the installing contractor to see that all controls are correctly installed and are operating properly when installation is complete including verifying that the limit sensor is fully installed (seated in bottom of Well).
- Failure to properly install Limit Sensor may result in property damage, personal injury or loss of life due to elevated operating temperatures and/or pressures.
- This boiler is suitable for installation on combustible flooring. DO NOT install boiler on carpeting.
- DO NOT tamper with or alter the boiler or controls.
- Inspect flueways at least once a year - preferably at the start of the heating season. The inside of the combustion chamber, the vent system and boiler flueways should be cleaned if soot or scale has accumulated.
- When cleaning this boiler, take precaution to avoid damage to burner swing door insulation. If damaged, or if there is evidence of previous damage, burner swing door insulation must be replaced immediately.
- Oil Burner and Controls must be checked at least once a year or as may be necessitated.
- DO NOT operate unit with jumpered or absent controls or safety devices.
- DO NOT operate unit if any control, switch, component, or device has been subject to water.
- Boiler materials of construction, products of combustion and the fuel contain alumina, silica, heavy metals, carbon monoxide, nitrogen oxides, aldehydes and/or other toxic or harmful substances which can cause death or serious injury and which are known to the state of California to cause cancer, birth defects and other reproductive harm. Always use proper safety clothing, respirators and equipment when servicing or working nearby the appliance.

 **WARNING**

This boiler contains very hot water under high pressure. DO NOT unscrew any pipe fittings nor attempt to disconnect any components of this boiler without positively assuring the water is cool and has no pressure. Always wear protective clothing and equipment when installing, starting up or servicing this boiler to prevent scald injuries. DO NOT rely on the pressure and temperature gauges to determine the temperature and pressure of the boiler. This boiler contains components which become very hot when the boiler is operating. DO NOT touch any components unless they are cool.

- This boiler must be properly vented. The boiler must be connected to an approved chimney or vent system in good condition. Serious property damage could result if the boiler is connected to a dirty or inadequate chimney or vent system. The chimney must be inspected for any obstructions and cleaned prior to each heating season. A clean and unobstructed chimney flue is necessary to produce the minimum draft required to safely evacuate noxious fumes that could cause personal injury or loss of life. DO NOT operate boiler with the absence of an approved vent system. Evidence of loose debris and or condensate induced stains at the base of the chimney flue, connector or smokepipe joints may be signs of condensing flue gases. Flue gas condensate is corrosive, which requires special consideration and must be addressed immediately. Refer to "Natural Draft Venting (Chimney)" listed in Table of Contents below.
- This boiler needs fresh air for safe operation and must be installed so there are provisions for adequate combustion and ventilation air.
- This boiler is supplied with controls which may cause the boiler to shut down and not re-start without service. If damage due to frozen pipes is a possibility, the heating system should not be left unattended in cold weather; or appropriate safeguards and alarms should be installed on the heating system to prevent damage if the boiler is inoperative.
- This boiler is designed to burn No. 2 fuel oil including bio blends not exceeding 20% Bio Diesel (ASTM D396) only.
 - DO NOT USE with Flammable Liquids, Gasoline, Crankcase drainings, charcoal lighter fluid, or any oil containing gasoline.
 - DO NOT convert to any solid fuel (i.e., wood, coal).
 - DO NOT convert to any gaseous fuel (i.e., natural gas, LP).
 - DO NOT USE Raw Vegetable Oil (RVO) or any fuel blended with RVO
 - Use of untested/uncertified fuels could result in explosion, fire, personal injury, or death, and/or damage to equipment and property.
 - Never burn garbage or paper in this boiler.
- All flammable debris, rags, paper, woodscraps, etc., should be kept clear of the boiler at all times. Keep the boiler area clean and free of fire hazards.
- All boilers equipped with burner swing door have a potential hazard which, if ignored, can cause severe property damage, personal injury or loss of life. Before opening swing door turn off service switch to boiler to prevent accidental firing of burner outside the combustion chamber. Be sure to tighten swing door fasteners completely when service is completed.

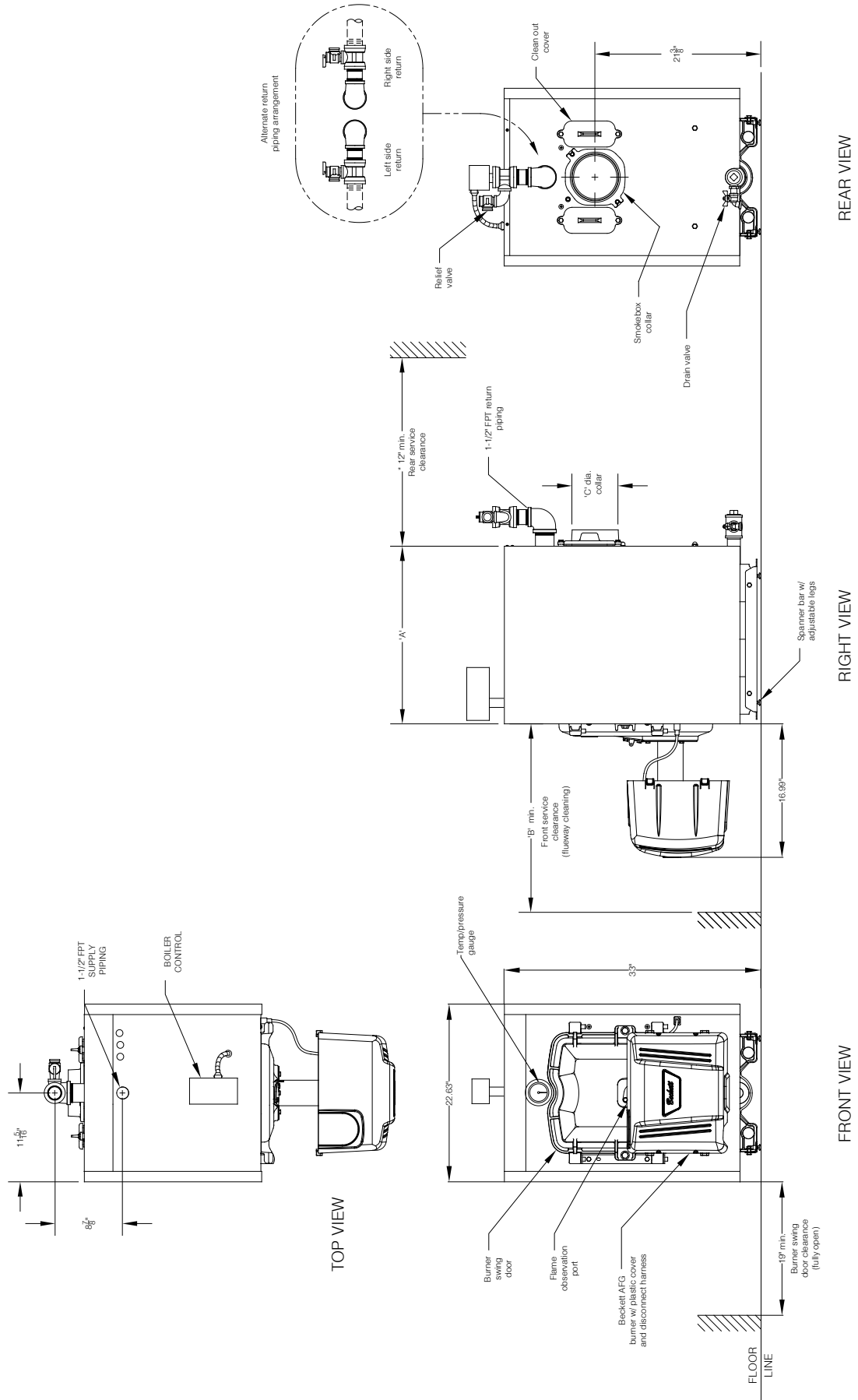

Figure 1-1: EMP Water Boiler

Table 1-2: Dimensional Data (see Figure 1-1)

Boiler Model No.	Dimensions See Figure 1-1			Water Content - Gallons	Heat Transfer Surface Area - Sq. Ft.	Actual Shipping Weight (LB.)
	"A"	"B"	"C"			
EMP84E/115E	16-5/8 in.	24 in.	5 in.	7.70	13.29	430
EMP140E	22-5/8 in.	24 in.	6 in.	11.08	20.29	545
EMP182E	28-5/8 in.	30 in.	6 in.	14.46	27.29	658
EMP224E/280E	34-5/8 in.	36 in.	7 in.	17.84	34.29	771
EMP336E	30-5/8 in.	36 in.	7 in.	21.22	41.29	884

Note: 1. Maximum Working Pressure: Water: 30 PSI Shipped From Factory (Standard), 40 PSI Optional, 50 PSI Optional

Table 1-3: Rating Data

Boiler Model No.	Burner Capacity		DOE Heating Capacity (MBH) (2)	Gross Output (2)	AHRI Net Ratings Water MBH	AFUE%	Thermal Efficiency %
	GPH	MBH (1)					
EMP84E	0.60	84	74		64	87.0	
EMP115E	0.80	115	101		88	87.0	
EMP140E	1.00	140	123		107	87.0	
EMP182E	1.30	182	160		139	87.0	
EMP224E	1.60	224	197		171	87.0	
EMP280E	2.00	280	244		212	86.0	
EMP336E	2.40	336		289	251		86.0

(1) MBH refers to thousands of BTU per hour.

(2) Based on Standard Test prescribed by the United States Department of Energy at combustion conditions of 13.0% CO₂.

(3) Net AHRI water ratings based on a piping and pickup allowance of 1.15.

Note: The rating shown are based on the use of #2 Heating Oil.

1 Pre-Installation

A. **INSPECT SHIPMENT** carefully for any signs of damage.

1. All equipment is carefully manufactured, inspected and packed. Our responsibility ceases upon delivery of crated boiler to the carrier in good condition.
2. Any claims for damage or shortage in shipment must be filed immediately against the carrier by the consignee. No claims for variances from, or shortage in orders, will be allowed by the manufacturer unless presented within sixty (60) days after receipt of goods.

B. **LOCATE BOILER** in front of final position before removing crate. See Figure 1-1.

1. LOCATE so that vent pipe connection to chimney will be short and direct.
2. BOILER IS SUITABLE FOR INSTALLATION ON COMBUSTIBLE FLOOR. Boiler cannot be installed on carpeting.
3. FOR BASEMENT INSTALLATION, provide a solid elevated base, such as concrete, if floor is not level, or if water may be encountered on floor around boiler.
4. PROVIDE RECOMMENDED SERVICE CLEARANCE, if applicable, as follows:
 - a. Clearance from Jacket Front Panel -
 - 24 in. for servicing burner

- a. Clearance from Jacket Front Panel -
 - 24 in. for flueway cleaning (EMP84E - 140E)
 - 30 in. for flueway cleaning (EMP182E)
 - 36 in. for flueway cleaning (EMP224E thru EMP336E)
 - b. Clearance from Jacket Side Panels -
 - 19 in. for burner swing door, if opened fully with burner mounted, otherwise 1 in. with burner removed
 - 12 in. access clearance to service rear of boiler if right side clearance is less than 12 in.
 - 3 in. minimum if right side clearance is 12 in. or larger to access and service rear of boiler.
 - c. Clearance from Jacket Rear Panel -
 - 12 in. minimum for rear smokebox cleaning

(Note: This dimension will also be controlled by horizontal to vertical to horizontal smokepipe arrangement - **Chimney Vent** (see Figures 1-4 and 4-1).

 - 24 in. for rear smoke box cleaning and disconnecting vent pipe from boiler adaptor for servicing (if required) - **Direct Vent** (see Figure 1-5).
5. For minimum clearances to combustible materials. See Figures 1-4 and 1-5.

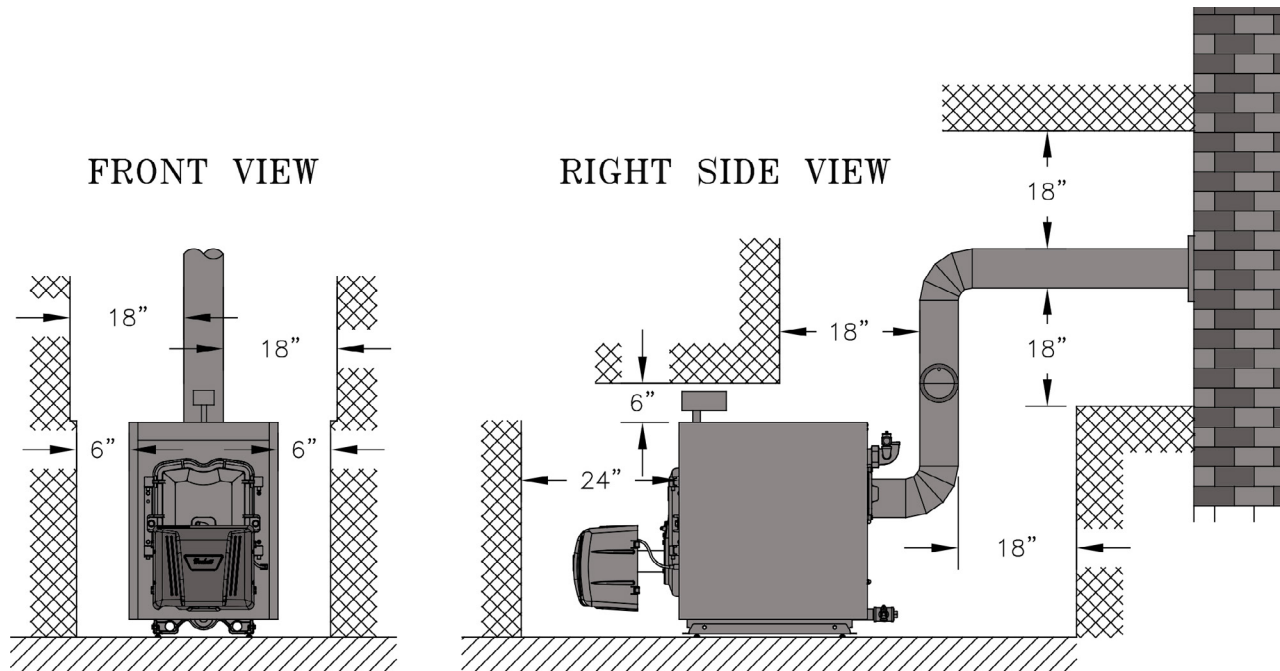

Figure 1-4: Chimney Vent - Minimum Installation Clearances To Combustible Materials (Inches)

- NOTES:**
1. Listed clearances comply with American National Standard ANSI/NFPA 31, *Standard for the Installation of Oil Burning Equipment*.
 2. EMP boilers can be installed in rooms with clearances from combustible material as listed above. Listed clearances cannot be reduced for alcove or closet installations.
 3. For reduced clearances to combustible material, protection must be provided as described in the above ANSI/NFPA 31 standard.

1 Pre-Installation *(continued)*

NOTICE: Clearance to venting is for single wall vent pipe. If Type L vent is used, clearance may be reduced to the minimum required by the vent pipe manufacturer.

C. PROVIDE COMBUSTION AND VENTILATION

AIR. Local and National Codes may apply and should be referenced.

⚠ WARNING

Adequate combustion and ventilation air must be provided to assure proper combustion and to maintain safe ambient air temperatures. Do not install boiler where gasoline or other flammable vapors or liquids, or sources of hydrocarbons (i.e. bleaches, fabric softeners, etc.) are used or stored.

1. Determine volume of space (boiler room). Rooms communicating directly with the space in which the appliances are installed, through openings not furnished with doors, are considered a part of the space.

$$\text{Volume(ft.}^3\text{)} = \text{Length(ft.)} \times \text{Width(ft.)} \times \text{Height(ft.)}$$

2. Determine total input of all appliances in the space. Add inputs of all appliances in the space and round the result to the nearest 1,000 BTU per hour.

3. Determine type of space. Divide Volume by total input of all appliances in space. If the result is greater than or equal to 50 ft.³/1,000 BTU per hour, then it is considered an **unconfined space**. If the result is less than 50 ft.³/1,000 BTU per hour then the space is considered a **confined space**.
4. For boiler located in an **unconfined space of a conventionally constructed building**, the fresh air infiltration through cracks around windows and doors normally provides adequate air for combustion and ventilation.
5. For boiler located in a confined space or an unconfined space in a building of **unusually tight construction**, provide outdoor air.
 - a. Outdoor air for combustion may be provided with an optional Fresh Air Accessory Kit (**ONLY AVAILABLE WITH BECKETT BURNER**). Plastic cover applications, P/N: 102119-01. Refer to Fresh Air Accessory Kit instructions for installation and air intake piping details.

or

- b. Outdoor air may be provided with the use of two permanent openings which communicate directly or by duct with the outdoors or spaces (crawl or attic) freely communicating with the outdoors. Locate remaining opening within 12 inches of bottom of space. Minimum dimension of air opening is 3 inches. Size each opening per following:

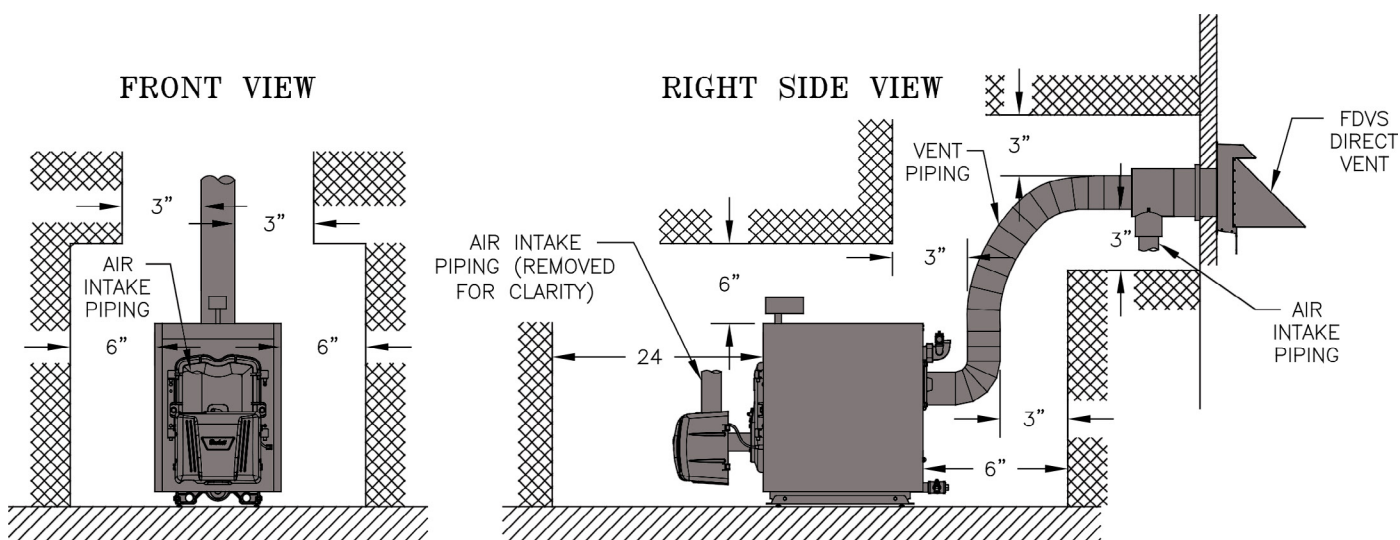

Figure 1-5: Direct Vent - Minimum Installation Clearances To Combustible Materials (Inches)

1 Pre-Installation *(continued)*

- i. **Direct communication with outdoors.** Minimum free area of 1 square inch per 4,000 BTU per hour input of all equipment in space.
- ii. **Vertical ducts.** Minimum free area of 1 square inch per 4,000 BTU per hour input of all equipment in space. Duct cross-sectional area shall be same as opening free area.
- iii. **Horizontal ducts.** Minimum free area of 1 square inch per 2,000 BTU per hour input of all equipment in space. Duct cross-sectional area shall be same as opening free area.

Alternate method for boiler located within confined space. Use indoor air if two permanent openings communicate directly with additional space(s) of sufficient volume such that be combined volume of all spaces meet criteria for unconfined space. Size each opening for minimum free area of 1 square inch per 1,000 BTU per hour input of all equipment in spaces, but not less than 100 square inches.

- 6. Louvers and Grilles of Ventilation Ducts
 - a. All outside openings should be screened and louvered. Screens used should not be smaller than 1/4 inch mesh. Louvers will prevent the entrance of rain and snow.
 - b. Free area requirements need to consider the blocking effect of louvers, grilles, or screens protecting the openings. If the free area of the louver or grille is not known, assume wood louvers have 20-25 percent free area and metal louvers and grilles have 60-75 percent free area.
 - c. Louvers and grilles must be fixed in the open position, or interlocked with the equipment to open automatically during equipment operation.

D. **DIRECT VENT CONFIGURATIONS** requires:

- 1. Beckett NX Burner
 - 2. Direct Vent Conversion Kit
 - 3. Double Wall Flex Oil Vent Pipe (FOVP).
- Horizontal ducts.** Minimum free area of 1 square inch per 2,000 BTU per hour input of all equipment in space. Duct cross-sectional area shall be same as opening free area.

Alternate method for boiler located within confined space. Use indoor air if two permanent openings communicate directly with additional space(s) of sufficient volume such that combined volume of all spaces meet criteria for unconfined space. Size each opening for minimum free area of 1 square inch per 1,000 BTU per hour input of all equipment in spaces, but not less than 100 square inches.

- 4. Louvers and Grilles of Ventilation Ducts
 - a. All outside openings should be screened and louvered. Screens used should not be smaller than 1/4 inch mesh. Louvers will prevent the entrance of rain and snow.
 - b. Free area requirements need to consider the blocking effect of louvers, grilles, or screens protecting the openings. If the free area of the louver or grille is not known, assume wood louvers have 20-25 percent free area and metal louvers and grilles have 60-75 percent free area.
 - c. Louvers and grilles must be fixed in the open position, or interlocked with the equipment to open automatically during equipment operation.

D. **DIRECT VENT CONFIGURATIONS** requires:

- 1. Beckett NX Burner
- 2. Direct Vent conversion Kit
- 3. Double Wall Flex Oil Vent Pipe (FOVP)

Table 1-6: Direct Vent Configuration Components

Boiler Model No.	Beckett NX Oil Burner Part No.	Direct Vent Conversion Kit Part No.	FOVP Carton Part No.
EMP140E	112207-01	102130-02	100212-02 - 10 ft.
EMP182E	112208-01		100214-02 - 20 ft.
EMP224E	112209-01	102130-03	100212-03 - 10 ft.
			100214-03 - 20 ft.

2 Packaged Boiler Assembly - Trim

A. REMOVE CRATE.

1. Remove all fasteners at crate skid.
2. Lift outside container and remove all other inside protective spacers and bracing. Remove miscellaneous parts carton.

B. REMOVE BOILER FROM SKID.

1. To reduce the risk of damage to boiler jacket, use the following procedure to remove from skid, see Figure 2-1:

Step 1. Boiler is secured to base with (4) 5/16 in. cap screws, (2) in front and (2) in rear of shipping skid, see Figure 2-1. Remove all securing hardware.

Step 2. Place wooden block(s) 12 in. from rear of skid as shown (one piece 4 in. x 4 in. x 16 in. lg. or two pieces of 2 in. x 4 in. x 16 in. lg.)

Step 3. Insert 1 in. Sch. 40 pipe handles through leg hole in front and rear legs. Center end of pipe on wooden blocks as shown in Figure 2-1.

NOTE: Pipe handles should extend a minimum of 48 in. beyond jacket front panel for best leverage.

Step 4. Using the pipe handles, lift boiler until adjustable legs are elevated above the deck boards.

Step 5. Remove skid from underneath the boiler.

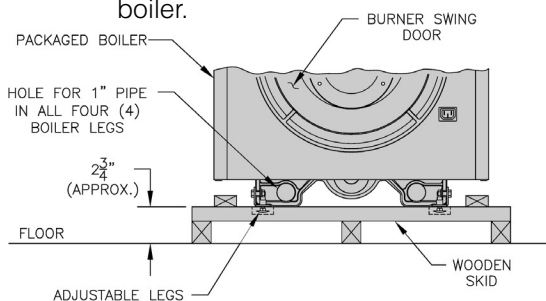

PARTIAL FRONT VIEW

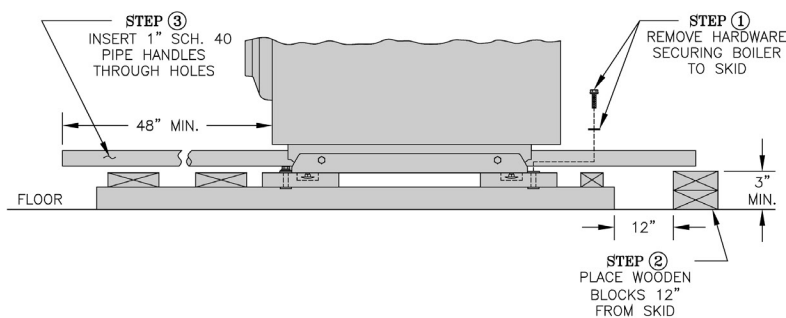

PARTIAL SIDE VIEW NO. 1

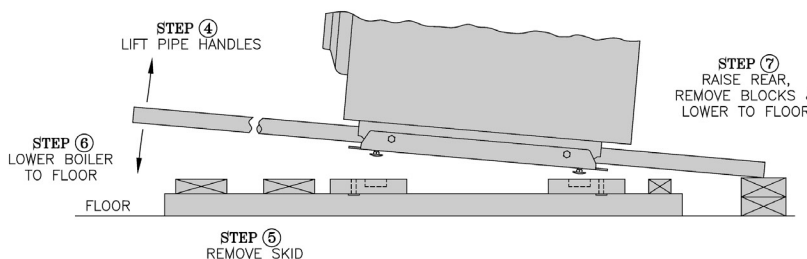

PARTIAL SIDE VIEW NO. 2

Figure 2-1: Packaged Boiler Removal from Skid

Step 6. Lower pipe handles until front adjustable legs touch floor. If necessary, place wooden blocks under front legs before lowering to provide hand clearance.

Step 7. To lower rear of boiler, tilt unit slightly forward by pushing on smokebox collar or lift pipes protruding through rear legs until wooden blocks can be removed (see Figure 2-1). Slowly allow the weight of the boiler to tilt backward until rear legs rest on floor.

Step 8. If wooden block was placed under front legs, lift pipe handles, remove wooden block and lower front legs to floor. Remove pipe handles.

CAUTION

Do not drop boiler. Do not bump boiler jacket against floor.

C. MOVE BOILER TO PERMANENT POSITION by sliding or walking.

D. PROCEDURE TO OPEN, CLOSE AND SECURE BURNER SWING DOOR

Throughout this manual you will be instructed to open and close the burner swing door for various reasons. There is a proper and improper method to closing and securing the burner swing door opened for inspection, cleaning or field service.

2 Packaged Boiler Assembly - Trim *(continued)*

1. TO OPEN BURNER SWING DOOR

(see Figures 2-2 and 2-3).

Step 1. Loosen but do not remove left side latching hardware (3/8 in. x 1-3/4 in. lg. tap bolt).

Step 2. Loosen and remove right side latching hardware (3/8 in. x 1-3/4 in. lg. tap bolt and washer).

Step 3. Remove left side latching hardware (3/8 in. x 1-3/4 in. lg. tap bolt and washer).

Step 4. Disconnect burner power cord from receptacle located in lower right corner of jacket front panel.

Step 5. Door can be swung to the fully open position, approximately 90° to 120°, with the burner mounted providing that there is 19 in. of clearance to the adjacent wall, see Figure 1-1.

NOTE: If reduced clearance prevents the door from opening fully, one of the following can provide full access:

- Burner can be removed to allow full rotation of door.
- Door with burner mounted can be lifted off mounting bracket and set aside during servicing.
- The door mounting hardware is reversible from left side hinge (as shipped) to right side hinge.

To reverse hinge arrangement (see Figure 2-2):

- Lift door off mounting bracket and set aside.
- Remove mounting bracket and hardware from left side.
- Remove upper jacket front panel retaining screw (5/16 in. x 1/2 in. lg. Phillip Pan head machine screw) from right side of door and re-install in vacated upper mounting bracket tapping. Do not tighten.
- Move lower jacket panel retaining screw from right side to left tapping. Do not tighten.
- Rotate door mounting bracket 180°. Insert 5/16 in. cap screw through top hole in bracket and install in upper vacated jacket hole on right side of door.
- Install second 5/16 in. cap through bracket hole into lower vacated tapping on right side.
- Tighten both sets of hardware to secure jacket and mounting bracket.
- Lift door and place integral cast hinge pins on door into slotted mounting bracket holes.

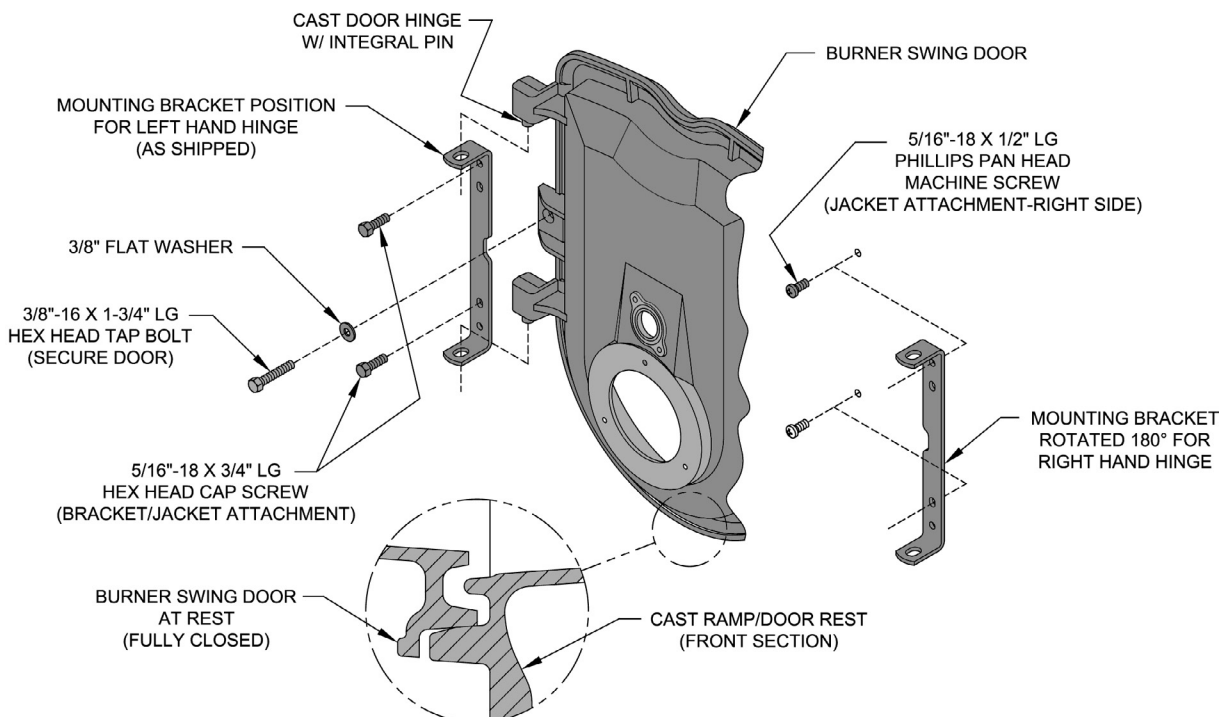
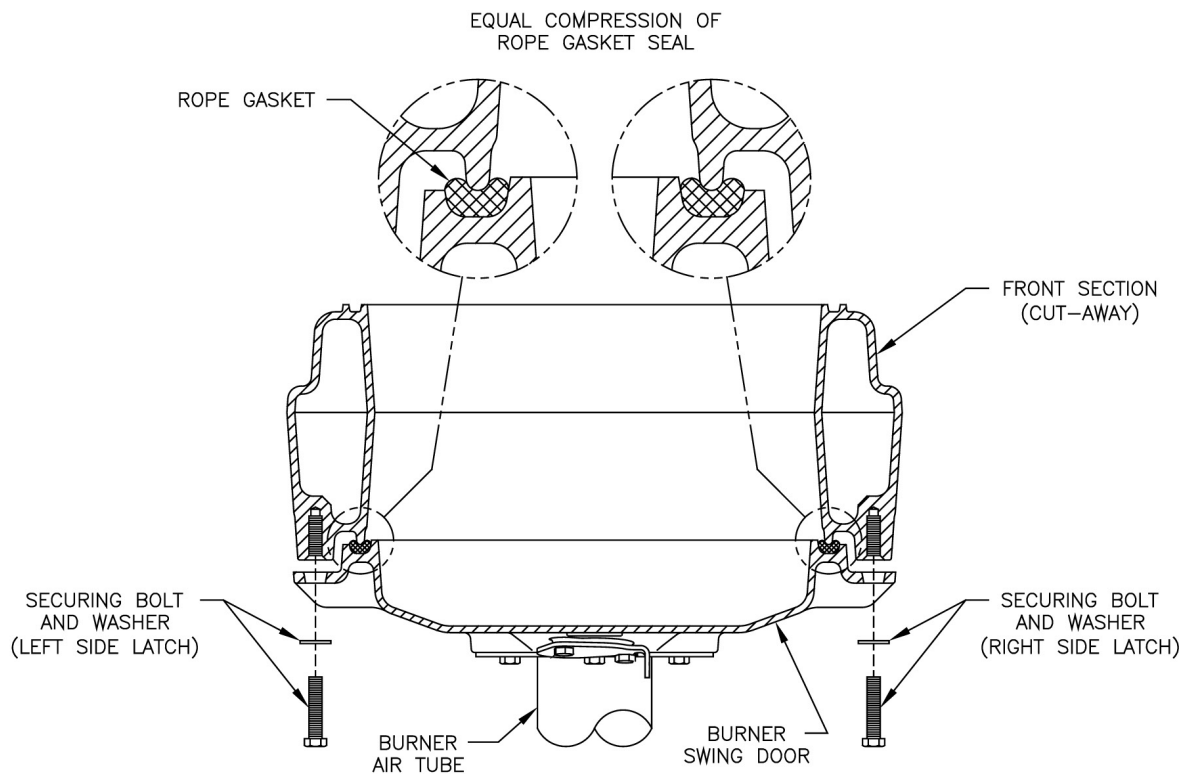
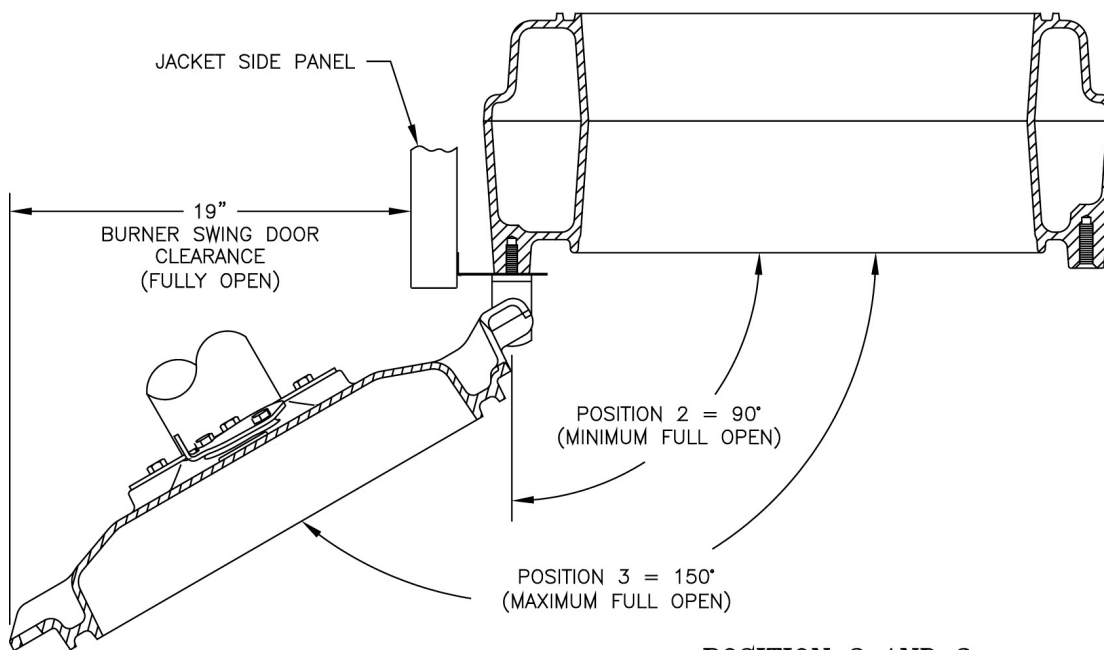

Figure 2-2: Partial Front View - Burner Swing Door Mounted to Boiler - Fully Closed and Secured

2 Packaged Boiler Assembly - Trim *(continued)*



POSITION 1
(PROPERLY CLOSED AND SECURED)



POSITION 2 AND 3
(SWING RADIUS TO FULL OPEN POSITION)

Figure 2-3: Top View - Burner Swing Door Mounted to Cast Iron Block Assembly (Jacket Removed for Clarity)

2 Packaged Boiler Assembly - Trim *(continued)*

2. Perform routine inspection, service or cleaning as necessary.
3. To close Burner Swing Door (see Figures 2-2 and 2-3):

Step 1. From the fully open position, rotate Burner Swing Door to the closed position.

Step 2. If necessary, place your right hand under the burner air tube to lift upward. Lift the door up unto the built-in cast ramp/door rest (protruding from the bottom of the front section casting - see Figure 2-2).

Step 3. Use one hand to help hold door in position by lifting up on rear burner housing or applying pressure directly to the door while re-installing the securing hardware with your opposite hand. **Always install right side latching hardware (3/8-16 in. x 1-3/4 in. lg. tap bolt and flat washer) first**, then install left side hinge hardware (3/8-16 in. x 1-3/4 in. lg. tap bolt and flat washer) **second**. Apply additional pressure while hand tightening the hardware as far as possible, then release the pressure.

NOTICE: When securing burner swing door make sure door is drawn-in equally on both sides.

Step 4. Use a hand wrench to tighten door hardware and **always start with the right side cap screw first**. Use an alternating tightening method from right side tap bolt to left side tap bolt to tighten door equally until sealed without applying excessive torque. **Never** tighten left side flange bolt first or tighten either piece of hardware 100% without using the alternating tightening method described above.

Failure to follow the prescribed procedure could cause thread damage to casting or a leak in the door seal. If left side tap bolt is tightened before right side tap bolt, right side of door can not be drawn-in to provide an air tight seal, as shown in Figure 2-4. Applying excessive torque will only cause thread damage.

E. INSPECT SWING DOOR INSULATION AND ROPE GASKET.

1. Open burner swing door using procedure previously outlined in Paragraph D of this section.
2. Inspect fiberglass rope located on the swing door. The rope must be evenly distributed around the perimeter of the door groove and cannot bunch or overhang. There must not be a gap where the two ends of the rope meet. Repair or replace if the rope is damaged or if there is a gap between the ends.

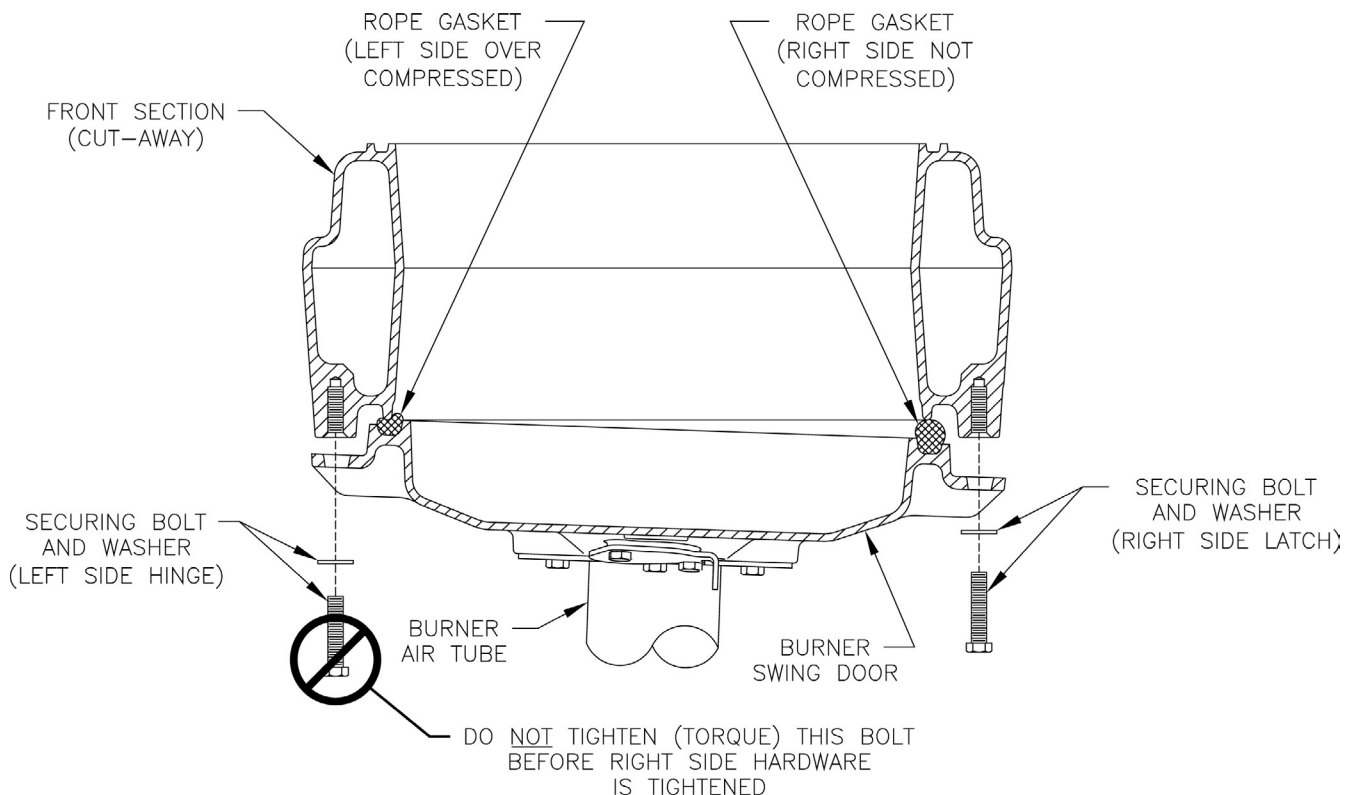

Figure 2-4: Top View - Burner Swing Door Fully Closed but Not Properly Secured or Sealed

2 Packaged Boiler Assembly - Trim *(continued)*

3. Inspect burner swing door insulation for damage and proper type.
 - a. By design, cast bars on front section between the combustion chamber and between the left and right side 2nd and 3rd pass flueway should make an impression in door insulation to seal the chambers.
 - b. By design, door insulation on model EMP224E& EMP280E will have two (2) by-pass pockets cast into the insulation centered on the bar between the combustion chamber and 3rd pass flueways.

On models EMP84E thru EMP182E, and EMP336E these pockets should not be present. If insulation is damaged or not of proper type regarding pockets, it must be replaced.
4. Do not close and secure door at this time, proceed to Field Assembly Details, Paragraph F.

F. FIELD ASSEMBLY OF BOILER TRIM Open miscellaneous parts carton and remove contents. Identify the components using the illustrations (see Figure 2-5 thru 2-9) throughout the assembly sequence outlined below as it applies to your installation.

1. Install return manifold and relief valve, refer to Figure 2-5.

Step a. Locate the return pipe fittings and injector. Apply sealant to the 2 in. NPT injector threads. Insert injector into 2 in. NPT upper rear tapping on rear section. Thread 2 in. NPT x 1-1/2 in. Reducing Elbow onto 2 in. NPT injector. Apply thread sealant to the 1-1/2 in. NPT nipple. Thread 1-1/2 in. nipple into 1-1/2 in. NPT end of reducing elbow. Thread 1-1/2 in. NPT x 1-1/2 in. NPT x 3/4 in. NPT Tee onto 1-1/2 in. NPT nipple. Tighten pipe fittings until relief valve orientation is correct for your installation and joints are watertight.

Note: Based on system return piping and access to service boiler, see Figures 1-1, 3-2 and 3-3, predetermine if manifold orientation is to be positioned for vertical, horizontal left or horizontal right side return piping as shown in Figure 2-5.

Step b. Install relief valve using 3/4 in. NPT tapping on tee. Relief valve must be installed in vertical position. If orientation of return manifold is for:

- 1-1/2 in. NPT vertical return piping - Install 3/4 in. NPT x 90° street elbow (not furnished) into 3/4 in. NPT tapping on tee. Install relief valve vertically into street elbow. See Figures 3-2 and 3-3.

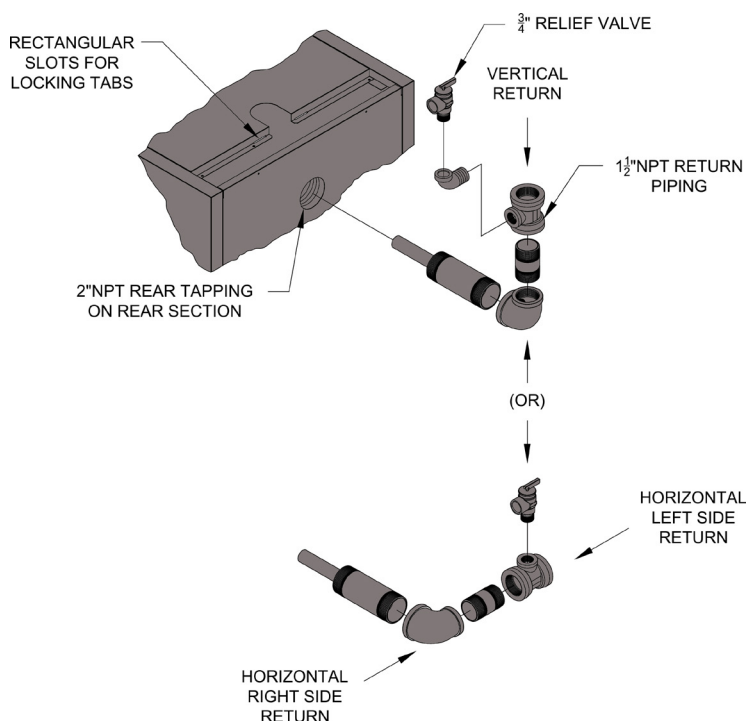

Figure 2-5: Return Manifold and Relief Valve Assembly Details

2 Packaged Boiler Assembly - Trim *(continued)*

- 1-1/2 in. NPT horizontal left or right side return piping - Install relief valve vertically in 3/4 in. NPT tapping on tee. See Figure 2-5.

Step c. Pipe discharge of relief valve as shown in Figures 3-2 and 3-3. Installation of the relief valve must be consistent with ANSI/ASME Boiler and Pressure Vessel Code, Section IV.

WARNING

Safety valve discharge piping must be piped near floor to eliminate potential of severe burns. Do not pipe in any area where freezing could occur. Do not install any shut-off valves, plugs or caps.

2. Install drain valve and indirect water heater return piping, see Figure 2-6.

Step a. Apply pipe sealant to both ends of 1-1/4 in. NPT x 5 in. lg. nipple. Thread nipple into 1-1/4 in. NPT lower rear tapping on rear section.

Step b. Thread 1-1/4 in. x 1-1/4 in. x 3/4 in. NPT tee on opposite end of 5 in. lg. nipple installed in Step a.

NOTE: Based on access for servicing and location of sewer or floor drain, when tightening these fittings, determine if drain valve is to be located on the left or right side.

Tighten nipple and tee into 1-1/4 in. NPT lower rear tapping or rear section until joints are water tight for desired position.

Step c. Apply sealant to 3/4 in. NPT thread on drain valve. Thread into 3/4 in. NPT tapping on side outlet of tee. Use hex nut portion to tighten valve until water tight.

Step d. If an Alliance™ SL water heater is connected to system, do not install 1-1/4 in. NPT pipe plug. Connect piping as shown in Figures 3-2 and 3-3, as applicable. Also refer to Alliance™ SL instructions for additional information.

3. Installing stainless steel flueway baffles. Baffle requirements differ from model to model, see Table 2-7.

NOTE: Read caution statement **before** proceeding.

Step a. Install stainless steel baffles provided in miscellaneous parts carton as follows, refer to Table 2-7 and Figure 2-8:

CAUTION

These baffles will generate higher efficiencies and lower stack temperatures. Under certain conditions, a lower gross stack temperature entering the chimney has the potential to be cooled below the dew point and create condensate on interior surfaces. Flue gas condensate is corrosive, which requires special consideration and must be addressed immediately.

DO NOT install baffles until you have read Sections 4, "Venting" completely.

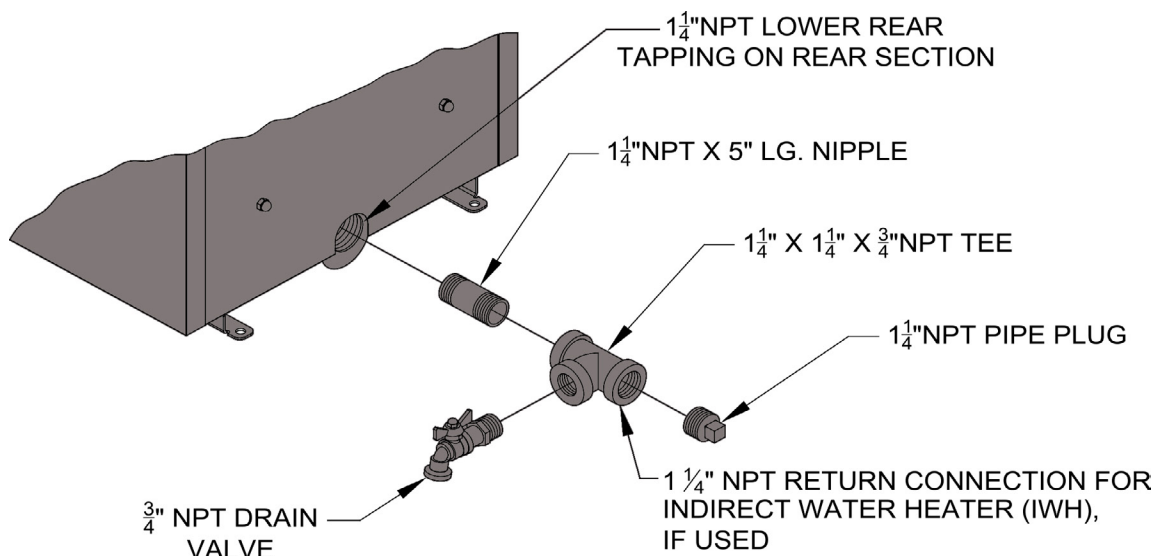

Figure 2-6: Piping Arrangement for Drain Valve and Indirect Water Heating Return

2 Packaged Boiler Assembly - Trim *(continued)*

- Model EMP84E - To install flueway baffle in 2nd pass on left side of boiler, hold baffle with word "Left" readable at the top. Slide baffle in flueway until position tab touches fins on left side of 2nd pass flueway. To install flueway baffle in 2nd pass flueway on right side of boiler, hold baffle with word "Right" readable at the top. Slide baffle in flueway until position tab touches fins on right side of 2nd pass flueway.

- Model EMP115E, EMP280E, and EMP336E - To install flueway baffle in 3rd pass on left side of boiler, hold baffle with word "Left" readable at the top. Slide baffle in flueway until position tab touches fins on left side of 3rd pass flueway. To install flueway baffle in 3rd pass flueway on right side of boiler, hold baffle with word "Right" readable at the top. Slide baffle in flueway until position tab touches fins on right side of 3rd pass flueway. To install flueway baffle in 2nd pass on left side of boiler, hold baffle with word "Left" readable at the top. Slide baffle in flueway until position tab touches fins on left side of 3rd pass flueway. To install flueway baffle in 2nd pass flueway on right side of boiler, hold baffle with word "Right" readable at the top. Slide baffle in flueway until position tab touches fins on right side of 3rd pass flueway.

Table 2-7: Baffle Usage

Boiler Model No.	Boiler Usage		
	2nd Pass	3rd Pass	Combustion Chamber
EMP84E	[2] 102066-01	None	None
EMP115E	[2] 109902-01	[2] 100081-01	[2] 111752-01
EMP140E	[2] 100042-01	None	None
EMP182E			
EMP224E			
EMP280E	[2] 112524-01	[2] 112525-01	
EMP336E	[2] 100042-01	[2] 100081-01	[1] 112523-01

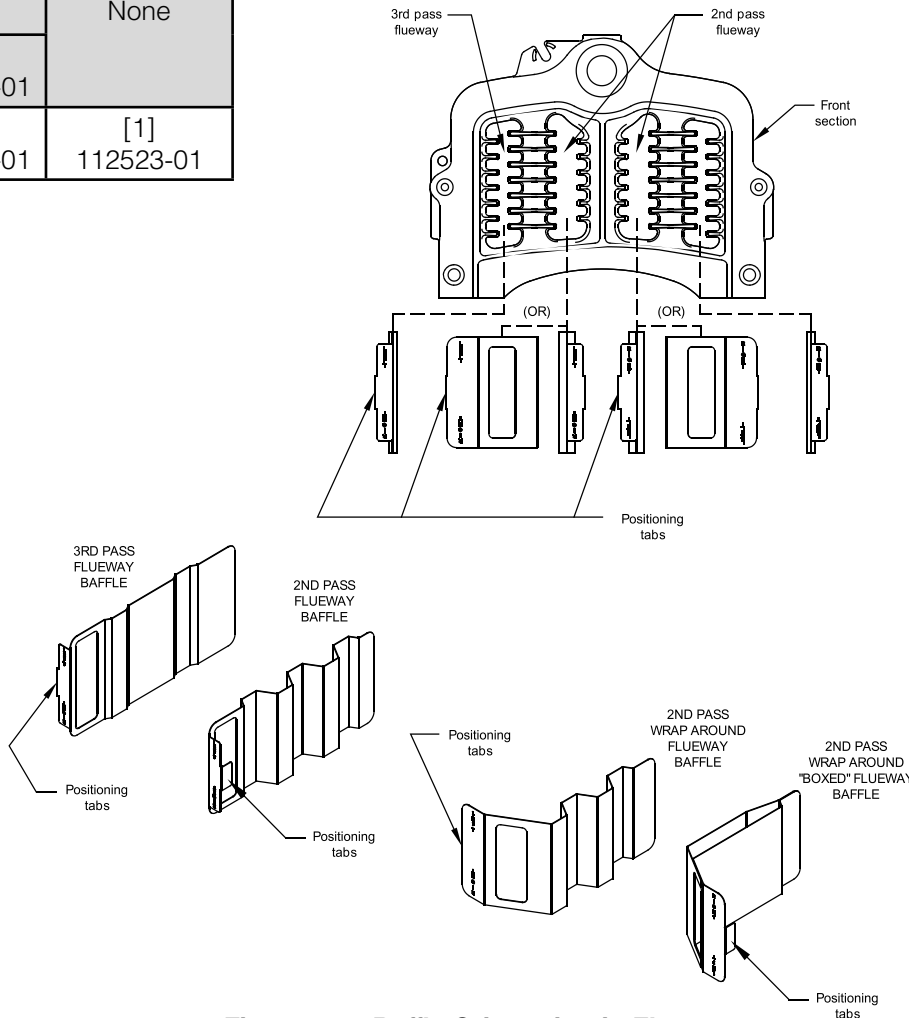
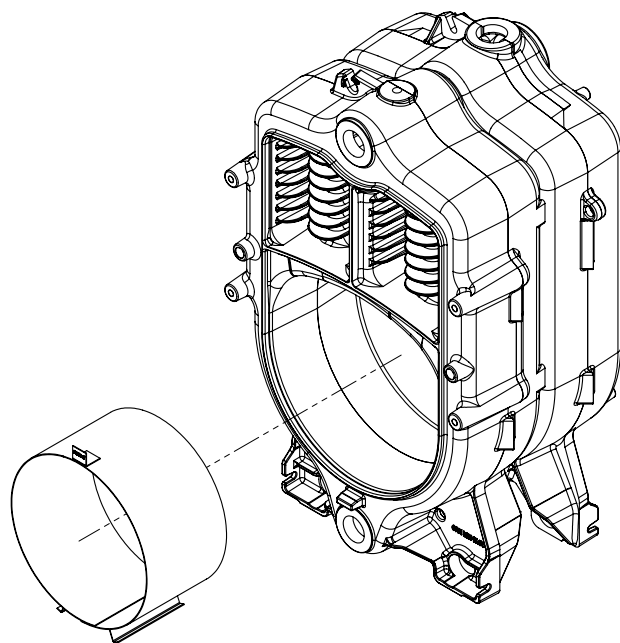

Figure 2-8: Baffle Orientation in Flueways

2 Packaged Boiler Assembly - Trim *(continued)*

To install the combustion chamber ring, place in the center of the combustion chamber. The positive stop will meet the front of the front section, positioning the Combustion Chamber Ring towards the front.



EXPLODED ISOMETRIC VIEW

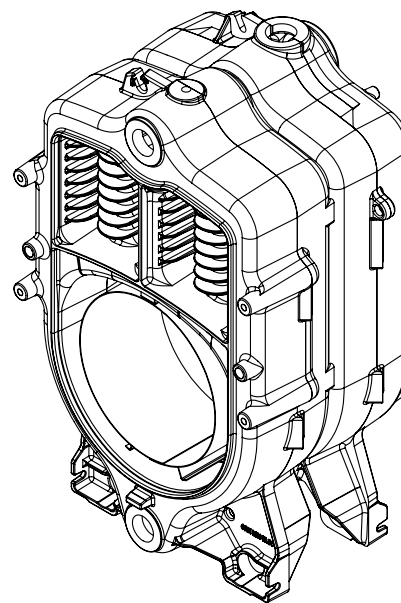

ASSEMBLED ISOMETRIC VIEW

Notes:

1. Jacket and Burner Swing Door have been removed for clarity.

Figure 2-9: Combustion Ring Installation

2 Packaged Boiler Assembly - Trim *(continued)*

- Models EMP140E, EMP182E and EMP224E - To install flueway baffle in 2nd pass flueway on left side of boiler, hold baffle with word "Left" readable at the top. Slide baffle in flueway until position tab touches fins on right side of 2nd pass flueway. To install flueway baffle in 2nd pass flueway on right side of boiler, hold baffle with word "Right" readable at the top. Slide baffle in flueway until position tab touches fins on left side of 2nd pass flueway.

NOTE: 2nd and 3rd pass flueway baffle are not interchangeable.

4. **Close the burner swing door** and securely seal the door to the boiler front section by reinstalling the hardware and securing the door using procedure previously outlined in Paragraph D of this section.

NOTICE: When securing burner swing door make sure door is drawn-in equally on both sides.

5. **Install oil burner.** (See Figure 2-10)

Step a. Open burner carton and remove contents.

Step b. Place oil burner gasket on burner and align holes.

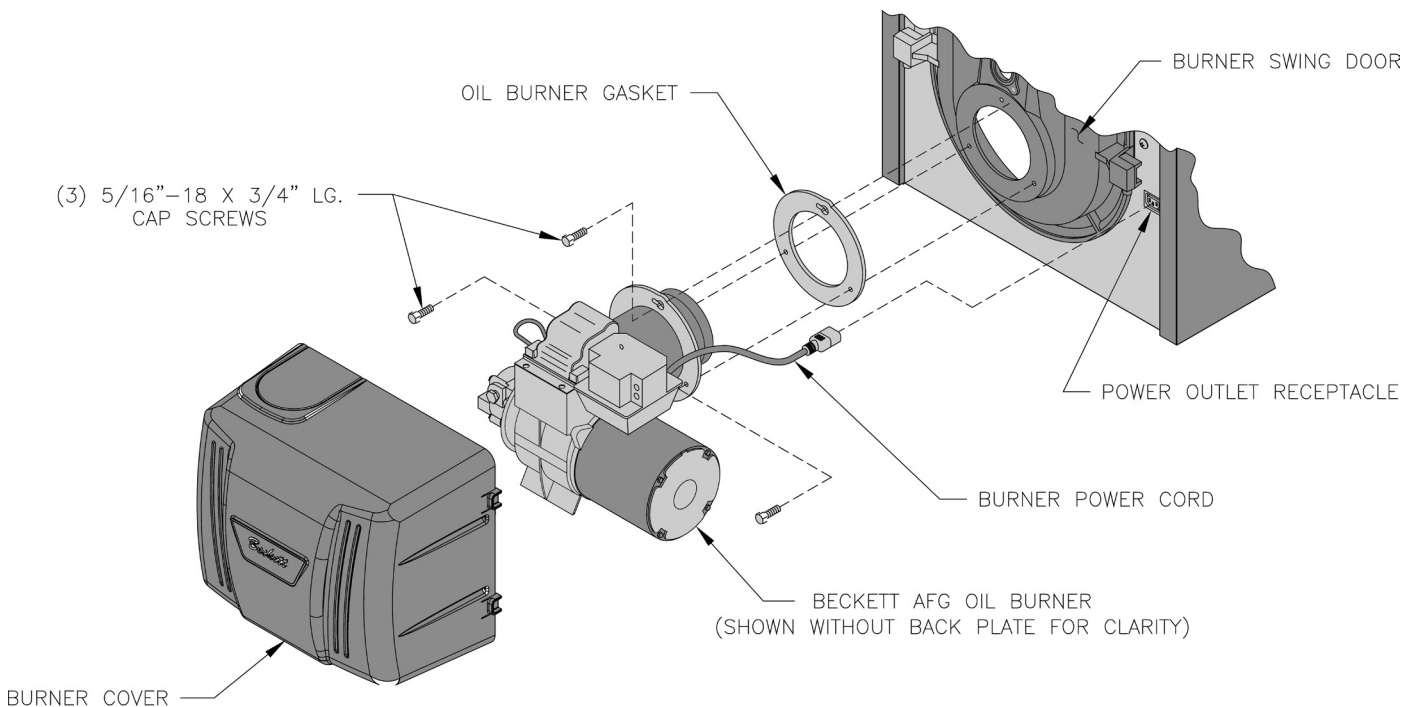

Figure 2-10: Beckett Oil Burner Installation

⚠ CAUTION

Do not install burner without gasket.

Step c. Remove three (3) 5/16-18 x 3/4 lg. cap screw from burner swing door used for mounting burner.

Step d. Thread (1) 5/16-18 x 3/4 lg. cap screw, approximately three (3) full turns, into tapping located at 12:00 o'clock on burner swing door.

Step e. Insert oil burner into the opening of burner swing door. Align and engage keyhole slot in burner flange over head of protruding cap screw installed in previous Step. Rotate burner to the right to lock flange behind head of cap screw.

Step f. Align holes and install two (2) remaining cap screws. Level burner and fully tighten all three (3) screws.

Step g. Plug burner power cord into Burner Receptacle.

Step h. Check oil nozzle in burner for size, angle and spray type; inspect electrode settings and head/air plate setting. Refer to Tables 3-2, 3-3 and Section 10.

3 Water Boiler Piping

NOTICE: Failure to pipe boiler as specified in this manual may result in excessive system noise.

A. EVALUATE THE EXISTING WATER SYSTEM.

Design a piping system and install boiler which will prevent oxygen contamination of boiler water and frequent water additions.

1. There are many possible causes of oxygen contamination such as:
 - a. Addition of excessive make-up water as a result of system leaks.
 - b. Absorption through open tanks and fittings.
 - c. Oxygen permeable materials in the distribution system.
2. In order to insure long product life, oxygen sources must be eliminated. This can be accomplished by taking the following measures:
 - a. Repairing system leaks to eliminate the need for addition of make-up water.
 - b. Eliminating open tanks from the system.
 - c. Eliminating and/or repairing fittings which allow oxygen absorption.
 - d. Use of non-permeable materials in the distribution system.
 - e. Isolating the boiler from the system water by installing a heat exchanger.

WARNING

System supply and return piping must be connected to correct boiler manifolds.

U. S. Boiler Company recommends sizing the system circulator to supply sufficient flow (GPM) to allow a 20°F temperature differential in the system. When sizing the system circulator, the most restrictive single zone should be used to determine maximum pressure drop.

CAUTION

Maintain minimum ½ inch clearance from hot water piping to combustible materials.

3. In order to insure long product life, operate boiler at appropriate flow rate to minimize areas of overheating.
 - a. Design system to ensure that the flow is above the limit called for in Table 5-2.
 - b. Maintain a constant boiler pressure of 12 PSI.

Table 3-1: Minimum Flow Rate

Boiler Model No.	Flow Rate (Gal / Min)
EMP84E	4.5
EMP115E	4.5
EMP140E	8.0
EMP182E	10.0
EMP224E	12.0
EMP280E	14.5
EMP336E	17.5

WARNING

Do not operate boiler below minimum volumetric flow rates.

B. CONNECT SYSTEM SUPPLY AND RETURN PIPING TO BOILER. See Figures 3-2 and 3-3.

Also, consult I=B=R Installation and Piping Guides.

1. If boiler is used with an Alliance™ SL Indirect Fired Domestic Water Heater, install the Alliance™ SL as a separate heating zone. Refer to the Alliance™ SL Installation, Operating, and Service Instructions, for additional information.
2. The EMP is designed to withstand thermal shock from return water temperatures as low as 100°F, but prolonged return temperatures of below 135°F can cause excessive flue gas condensation and damage the boiler and/or venting system.

Use a boiler bypass if the boiler is to be operated in a system which has a large volume or excessive radiation where low boiler water temperatures may be encountered (i.e. converted gravity circulation system, etc.) The bypass should be the same size as the supply and return lines with valves located in the bypass and return line as illustrated in Figures 3-2 and 3-3 in order to regulate water flow for maintenance of higher boiler water temperature.

3. **If it is required to perform a long term pressure test to the hydronic system,** the boiler should first be isolated to avoid pressure loss due to the escape of trapped air.

To perform a long term pressure test including the boiler, ALL trapped air must first be removed from the boiler.

A loss of pressure during such a test, with no visible water leakage, is an indication that the boiler contained trapped air.

3 Water Boiler Piping (continued)

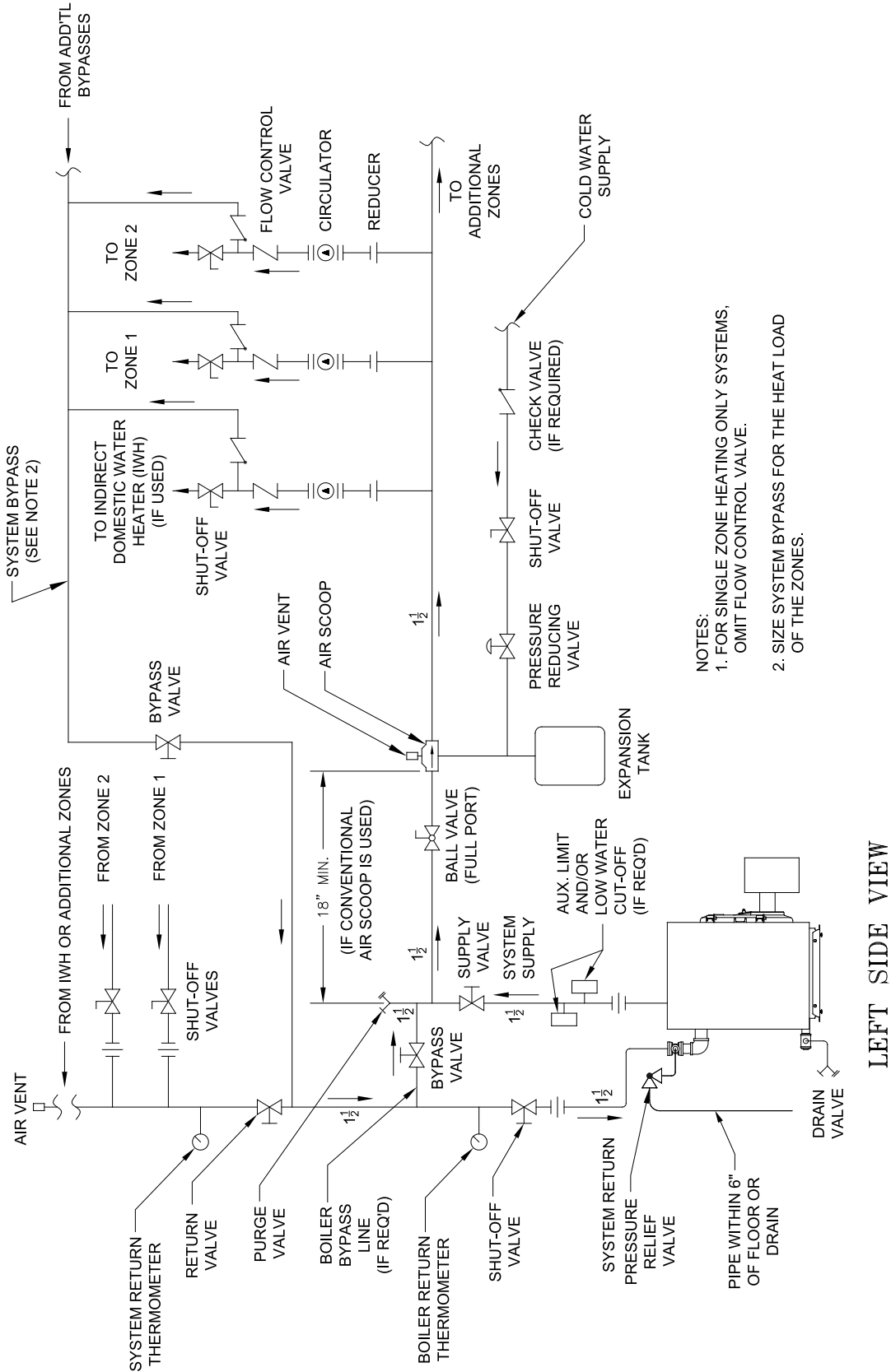

- NOTES:
1. FOR SINGLE ZONE HEATING ONLY SYSTEMS, OMIT FLOW CONTROL VALVE.
 2. SIZE SYSTEM BYPASS FOR THE HEAT LOAD OF THE ZONES.

Figure 3-2: Recommended Water Piping for Circulator Zoned Heating Systems

3 Water Boiler Piping (continued)

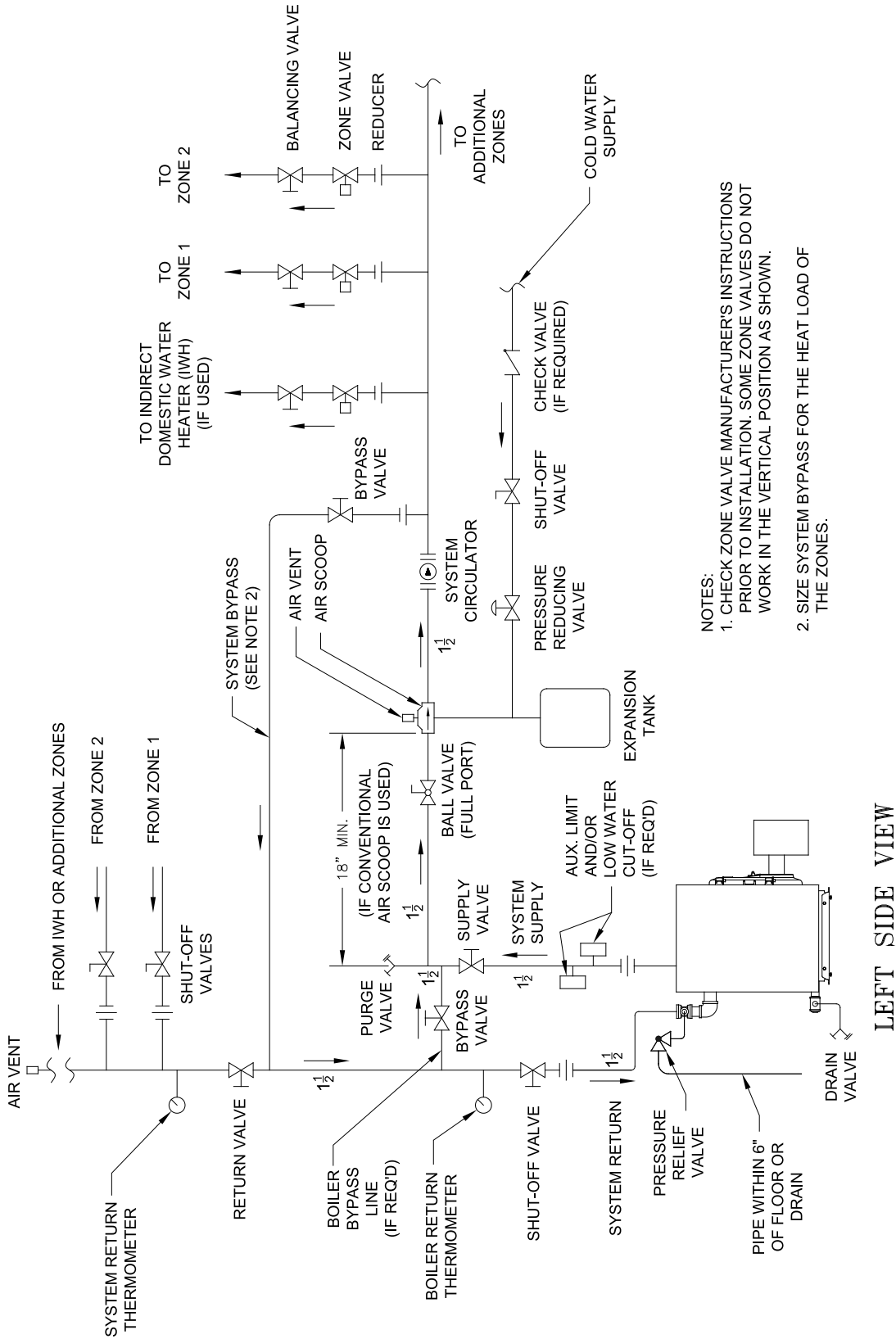

- NOTES:
1. CHECK ZONE VALVE MANUFACTURER'S INSTRUCTIONS PRIOR TO INSTALLATION. SOME ZONE VALVES DO NOT WORK IN THE VERTICAL POSITION AS SHOWN.
 2. SIZE SYSTEM BYPASS FOR THE HEAT LOAD OF THE ZONES.

Figure 3-3: Recommended Water Piping for Zone Valve Zoned Heating Systems

LEFT SIDE VIEW

4 Natural Draft Venting (All Boiler Models)

WARNING

Vent this boiler according to these supplemental instructions. Failure to do so may cause products of combustion to enter the home resulting in severe property damage, personal injury or death.

- Insufficient Combustion Air Supply may result in the production and release of deadly carbon monoxide (CO) into the home which can cause severe personal injury or death.
- Improper venting may result in property damage and the release of flue gases which contain deadly carbon monoxide (CO) into the home, which can cause severe personal injury, death, or substantial property damage.
- Inspect existing chimney and vent connector for obstructions and deterioration before installing boiler. Failure to clean or replace perforated pipe or chimney liner will cause severe injury or death.
- Do not de-rate the appliance. Failure to fire the boiler at it's designed input may cause excessive condensation upon the interior walls of the chimney. In addition, the lower input may not create enough draft to adequately evacuate the by-products of combustion.

A. CHIMNEY VENTING

1. Chimney venting is an important part of a safe and efficient oil fired appliance system. Contact your local fire and building officials on specific requirements for restrictions and the installation of fuel oil burning equipment. In addition, consult with a professional knowledgeable on the requirements of NFPA 31 – Standard for the Installation of Oil-Burning Equipment and NFPA 211 - Standard for Chimneys, Fireplaces, Vents, and Solid Fuel-Burning Appliances for installations in the United States. Installations in Canada must be reviewed with a professional knowledgeable on the requirements of CSA B139 – Installation Code for Oil-burning Equipment.
2. The safe venting of oil fired boilers is dependant on many factors. Some of these factors include:
 - a. sufficient draft during the entire heating season to allow for the safe discharge of combustion by-products and;
 - b. suitable corrosion protection in the event of condensing flue gases. Only a trained and qualified contractor may install this product.
3. The EMP shall be vented into any of the following:
 - a. Masonry or metal chimney. Build and install in accordance with local buildings codes; or local authority having jurisdiction; or *Standards for Chimney, Fireplace, Vents, and Solid Fuel Burning Appliances*, ANSI/ NFPA 211 and/or National Building Code of Canada. Masonry chimney must be lined with listed chimney system. Listed clay flue lined masonry chimneys meet venting requirements.
 - External chimneys are more susceptible to flue gas condensation due to colder outside air temperatures. To prevent corrosion due to flue gas condensation, use a listed corrosion-resistant metal liner in chimney.
 - b. Oversized chimneys are more susceptible to flue gas condensation. To reduce the likelihood of flue gas condensation and ensure proper draft, use a properly sized listed metal liner in oversized chimney.
4. Chimney Inspection – Prior to the installation of any new or replacement fuel burning equipment the chimney shall be inspected by a qualified installer. The chimney shall be inspected for integrity as well as for proper draft and condensate control. Some jurisdictions require the use of a liner when changing fuel types. Some jurisdictions require the use of a liner even when the same fuel is used. At a minimum, the chimney shall be examined by a qualified person in accordance with the requirements of Chapter 11 of NFPA 211, Standard for Chimneys, Fireplaces, Vents, and Solid Fuel-Burning Appliances.
 - a. Loose Mortar – Loose mortar could be an indication of a prior history of condensing flue gases upon the inside walls of the chimney. Colder climates are more susceptible to this condition. Under no circumstances shall a chimney of this condition be used until it meets the requirements of NFPA 211 or CSA B139.
 - b. Unlined Chimney – Under no circumstances shall a chimney constructed of brick only be used. Only approved clay liners or listed chimney lining systems shall be used as specified in NFPA 31 or CSA B139.
 - c. Abandoned Openings – Openings through the chimney wall that are no longer used shall be sealed in accordance to NFPA 211. Often abandoned openings are improperly sealed and usually covered by a gypsum wall covering.
 - d. Clean Chimney – Chimney shall be free of all loose debris.

4 Natural Draft Venting *(continued)*

5. Draft Regulator – the draft regulator supplied with the boiler (or equivalent) must be used with this appliance. Refer to Figures 4-1 and 4-2.

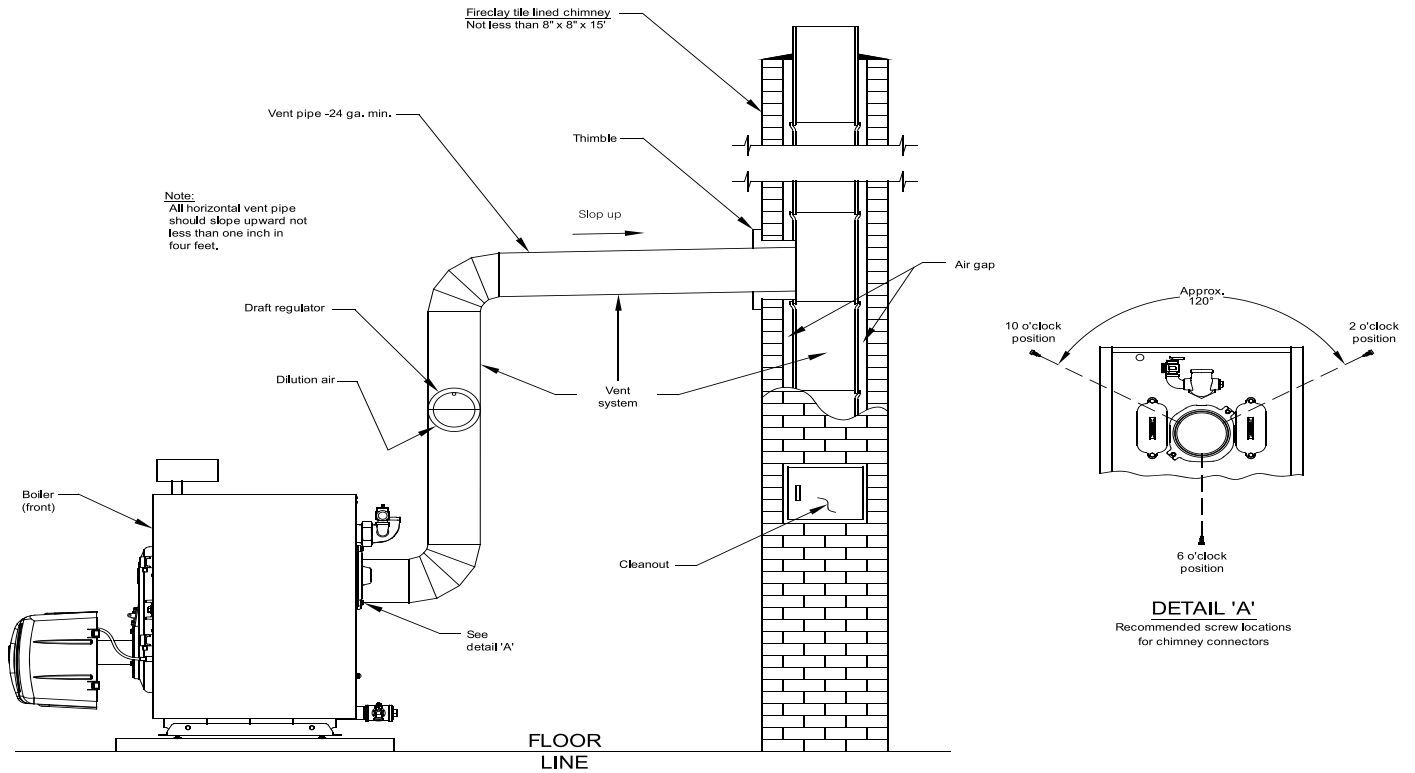

Figure 4-1: Recommended Vent Pipe Arrangement and Chimney Requirements

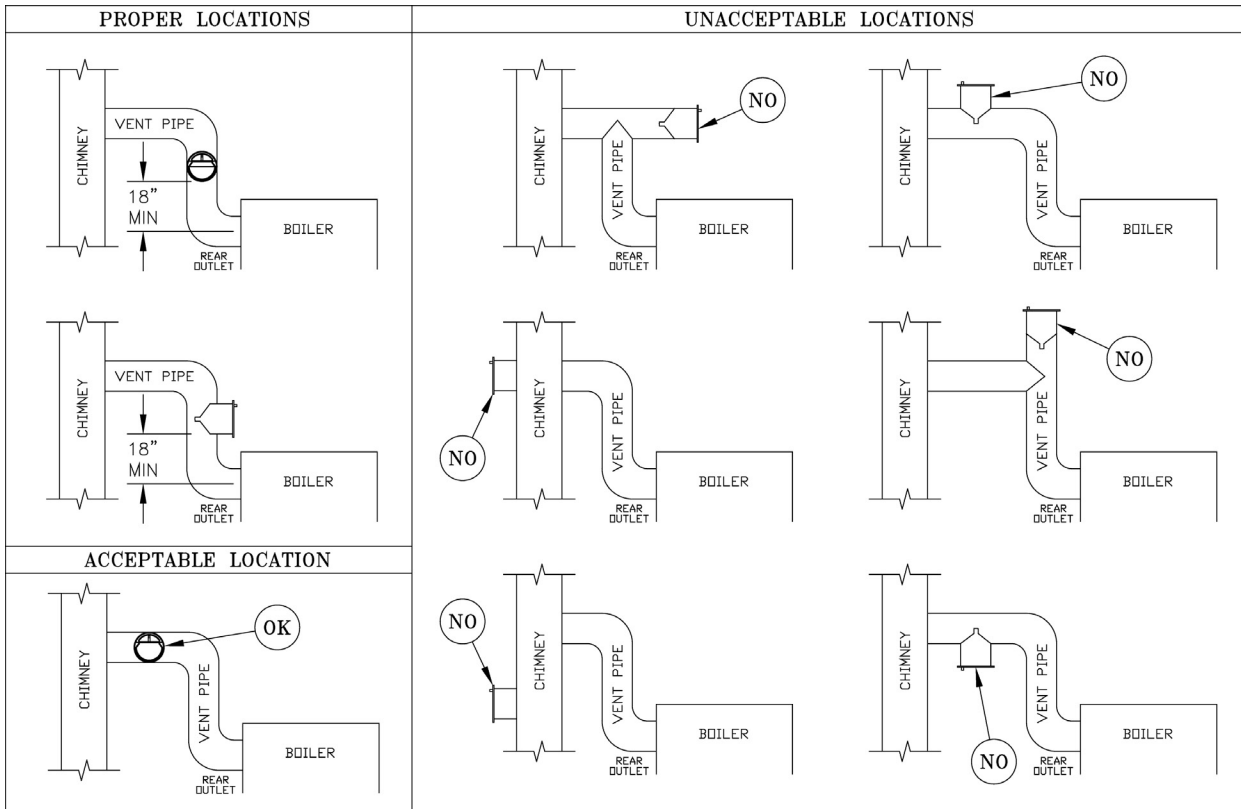

Figure 4-2: Proper and Improper Locations of Draft Regulator

4 Natural Draft Venting *(continued)*

B. CHIMNEY CONNECTOR

1. A chimney connector (vent pipe) is used to connect the boiler to the base of the chimney. The chimney connector should be kept as short as possible. The horizontal length of the chimney connector shall not be greater than 10 feet.

NOTE: Secure chimney connector to cast iron smokebox collar with three (3) #10 x ½ in. self drilling hex head TEK screws provided in miscellaneous parts carton. Locate screws around perimeter of connector as shown in Figure 5-4 and approximately ½ in. in from edge. Use drill with 5/16 in. hex bit to drive screws through connector and smokebox collar.

⚠ DANGER

The chimney and connector shall be inspected annually for signs of debris and corrosion. Loose mortar at the base of the chimney may be a sign of condensate damage to the chimney. A chimney professional shall be contacted immediately to examine the damage and recommend a solution. Long term operation while in this condition may cause a venting failure and force flue gases into the living space. If the chimney is to be re-lined use the recommendations in NFPA 31, Appendix E or CSA B139.

2. Vent Connector shall be any of the following and of the same size as the outlet of boiler.
 - a. Type L or a factory built chimney material that complies with the Type HT requirements of ANSI/UL 103. Install in accordance with listing and manufacturer's instructions.
 - b. Steel pipe having resistance to corrosion and heat with a minimum wall thickness of 24 Gauge (0.024 in.).

⚠ DANGER

Any signs of condensate seepage at the base of the chimney shall be inspected immediately. The discoloration may be a sign of chimney damage and must be remedied immediately.

C. DRAFT

1. The natural draft generated through a chimney is dependent on several factors including, chimney height, temperature of flue gases, cross section area of chimney, chimney wall insulation value, dilution air and total volume of flue gases, to name a few. Make sure that the boiler has been running for at least 5 minutes before measuring the draft.

2. Minimum Draft at Breech (Canopy) – The draft induced by a chimney must create at least a pressure of 0 (zero) inches water column (" w.c.) at the pressure tapping on the canopy mounted on rear of boiler (see Figure 5-6). The pressure at the canopy **cannot** be positive since this could create a condition that allows flue gas by-products to escape from the draft regulator. A negative pressure reading up to -.03 inches water column is acceptable for proper operation. (See Tables 14-1 and 14-2) Burner Specifications at the rear of this manual for more details)
3. Minimum Overfire Pressure – The overfire pressure is another piece of information that is often measured, however this should be done for observation purposes only! The breech pressure must be used to qualify the draft condition. See Tables 14-1 and 14-2 for more details as a guide. Actual draft and temperature measurements may be different than those values in the table.

D. STACK TEMPERATURE

1. The temperature of the flue gases has a significant effect on the amount of draft created in a vertical chimney as well as the propensity to create condensate. The higher the stack temperature, the greater the amount of draft that can be generated. A lower stack temperature not only reduces the amount of draft that can be created but it also increases the possibility that the flue gases could condense in the chimney connector or stack.

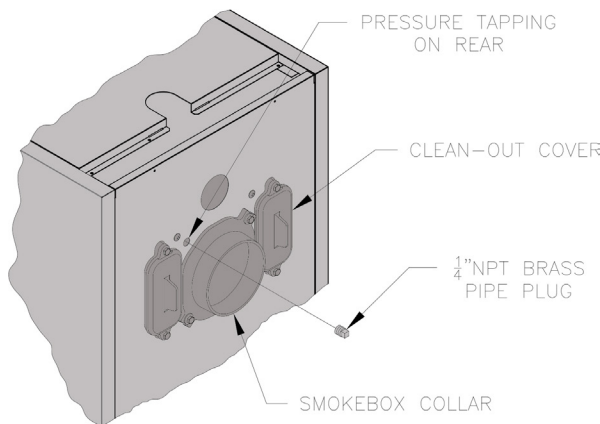

Figure 4-3: Smokebox Pressure Tapping for Checking Draft at Breech

4 Natural Draft Venting *(continued)*

- NFPA 31 and CSA B139 have information to help the installer make an appropriate choice of venting materials. In some cases a chimney may have to be lined to create sufficient draft. In other cases, the chimney may have to be lined to prevent the corrosion of a masonry chimney. Consult with a chimney specialist knowledgeable on the requirements for chimney requirements in your area.

CAUTION

Any doubt on the condition of a chimney or its ability to prevent the generation and accumulation of flue gas condensate, must be relined according to NFPA 31 (United States) or CSA B139 (Canada).

CAUTION

Use the chimney venting tables as a guide. It is highly recommended that any borderline application should result in the relining of the chimney with a suitable liner that creates sufficient draft and to protect against corrosion caused by flue gas condensate.

- Baffles – The efficiency of the boiler is based on the insertion of flue baffles supplied with your product. Under no circumstances are other baffles to be used on this product. Refer to Section 2, Item F, Paragraph 3 for baffle installation. If there is any doubt on the application of this boiler on the intended chimney, consult with your local code officials. At a minimum, remove the baffles to increase the stack temperature. See Tables 14-1 and 14-2 for temperature differential (ΔT) with baffles IN and OUT. In addition, the lower the CO_2 level the higher the stack temperature.

WARNING

Remove the baffles if there are any signs of condensation in the chimney or chimney connector. Consult with your local chimney professional for recommendations.

E. MINIMUM CLEARANCES

See Figure 1-4 for details regarding clearances to combustibles for the boiler.

F. OPTIONAL AIR INTAKE PIPING INSTALLATION

- All air for combustion can be supplied directly to the burner from outdoors providing that the criteria for chimney, vent connector and minimum stack temperature outlined in this section can be maintained. **(ONLY AVAILABLE WITH BECKETT BURNER)**. Refer to Section 1, Paragraph C, Steps 5 and 6 for optional air intake piping installation information.

5 Direct Venting / Air Intake Piping (Boiler Models EMP140E Thru 224E Only)

A. GENERAL GUIDELINES

1. DirectVent system must be installed in accordance with these instructions and applicable provisions of local building codes. Contact your local fire and building officials on specific requirements for restrictions and the installation of fuel oil burning equipment. In addition, for boiler installation in United States, consult with a professional knowledgeable on requirements of NFPA 31- *Standard for the Installation of Oil-Burning Equipment* and NFPA 211 *Standard for Chimney, Fireplaces, Vents and Solid Fuel-Burning Appliances*, latest editions.
2. In the Direct Vent configuration, all air for combustion is supplied directly to the burner from outdoors, and, flue gases are vented directly outdoors (thru wall), via Direct Vent System (FDVS), which is a non-positive pressure vent system termination for oil-fired appliances, that provides an outlet for products of combustion, and, an intake for combustion air in a single concentric terminal.
3. Direct Vent Hood Assembly minimum clearance to combustible material is 0 in.
4. Maximum wall thickness that FDVS vent termination may be installed through is 12 in.

⚠ WARNING

This venting system must be installed by a qualified installer (an individual who has been properly trained) or a licensed installer.

DO NOT locate vent termination where exposed to prevailing wind. Moisture and ice may form on surfaces around vent termination. To prevent deterioration, surface must be in good repair (sealed, painted etc.).

DO NOT locate vent termination where petroleum distillates, CFC's, detergents, volatile vapors or any other chemicals are present. Severe boiler corrosion and failure will result. DO NOT locate vent termination under a deck.

5. Locate the vent terminal so vent pipe is short and direct, and, at the place on exterior wall that complies with the minimum distances as specified in Figure 5-1 and listed as follows. The vent termination must be located (as measured to the bottom of vent terminal):
 - a. Not less than 12 in. above finished grade or expected snow accumulation line whichever is greater.
 - b. Not less than 3 ft. above any forced air inlet located within 10 ft.

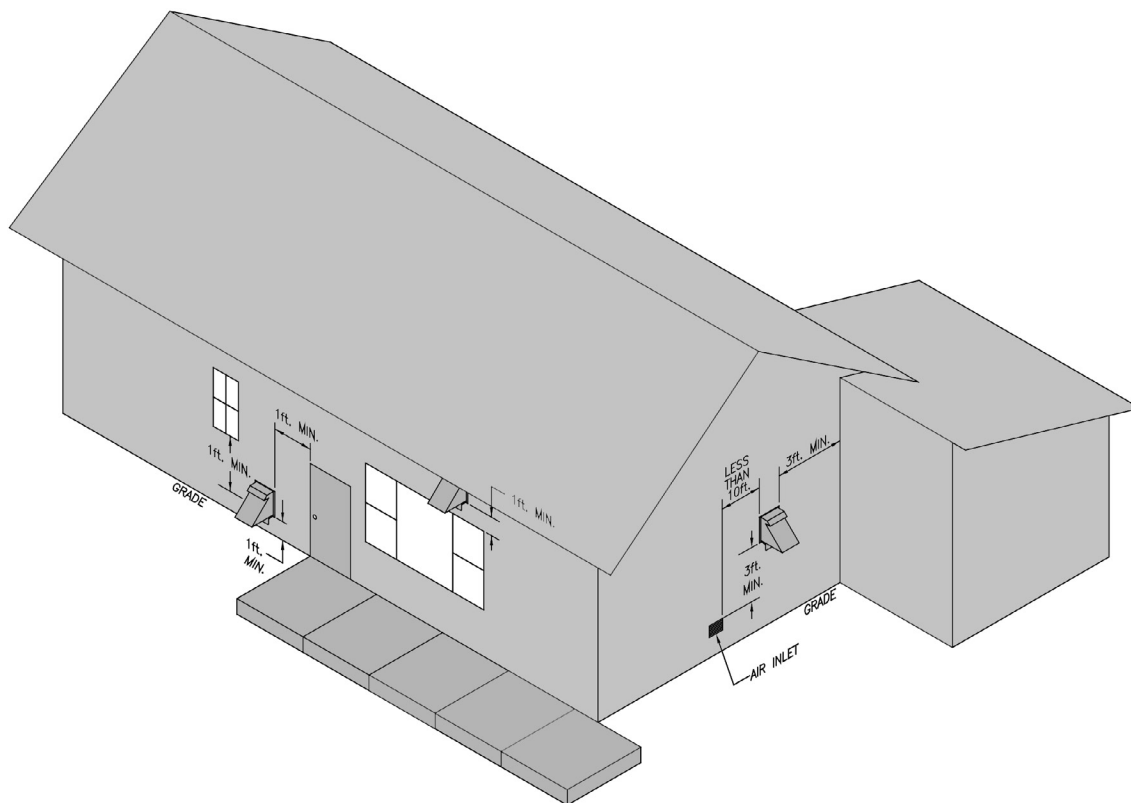

Figure 5-1: Vent Terminal Location

5 Direct Venting / Air Intake Piping *(continued)*

- c. Not less than 1 ft. from any door, window or gravity air inlet.
- d. Not less than 7 ft. above grade when located above public walkway.
- e. Not less than 3 ft. (as measured to side of vent termination) from an inside corner of an L-shaped structure.
- f. Not less than 1 ft. from the nearest surface of the terminal to a roof soffit.
- g. Not directly above, or, not less than 6 ft. horizontally from an oil tank vent or gas meter.
- h. Not less than 2 ft. from nearest surface of terminal to an adjacent building.

B. INSTALLATION OF THE VENT HOOD TERMINAL

1. Inspect Direct Vent Conversion Kit Carton for damage. **DONOT** install if any damage is evident.
2. Direct Vent Conversion Kit Carton includes (see Figures 5-4 thru 5-6):
 - Direct Vent Hood Assembly (consists of Vent Hood Body and Vent Hood Tee) – 1 pc
 - Backing Plate – 1 pc
 - Vacuum Relief Valve VRV-4 – 1 pc
 - Hardware Bag (includes high temperature sealant, fasteners and inner pipe clamps) – 1 pc
 - Appliance (Boiler Flue Outlet) Adapter – 1 pc
 - Appliance Clamp Halves – 2 pcs
 - Cover Sleeve Assemblies – 2 pcs
 - Cover Ring Assemblies – 2 pcs
3. Remove vent system components from carton and set aside.
4. Separate the vent hood tee from the vent hood body and set aside for later use.
5. After determining the location of the venting system termination, cut the square hole in the wall sized according to "L" dimension in Table 5-2, see Figure 5-3.
6. Wood or vinyl siding should be cut, so that vent hood base plate mounts directly on the wallboard to provide stable support. If siding thickness exceeds ½ in., use a spacer bar or board behind the vent hood mounting (base) plate. See Figure 5-4.
 - a. Seal the backside of the vent hood base plate around the outer pipe of the vent hood with a bead of high-temperature silicone sealant (provided in Bagged Hardware).
 - b. Mount the vent hood body from outside, through the wall, keeping the outer pipe centered in the hole.
 - c. Fasten the vent hood body to the outside wall with appropriate fasteners (installer provided).
 - d. Seal the edges of the vent hood base plate to the wall with a high-temperature silicone sealant (provided in Bagged Hardware).
 - e. While inside, position the backing plate over the outer pipe and fasten to inside wall with appropriate fasteners (installer provided).

Table 5-2: Wall Cutout Dimensions

Boiler Model No.	Direct Vent Conversion Kit Part No.	"L" Dimension (Inch)
EMP140E EMP182E	102130-02	8¼
EMP224E	102130-03	9¼

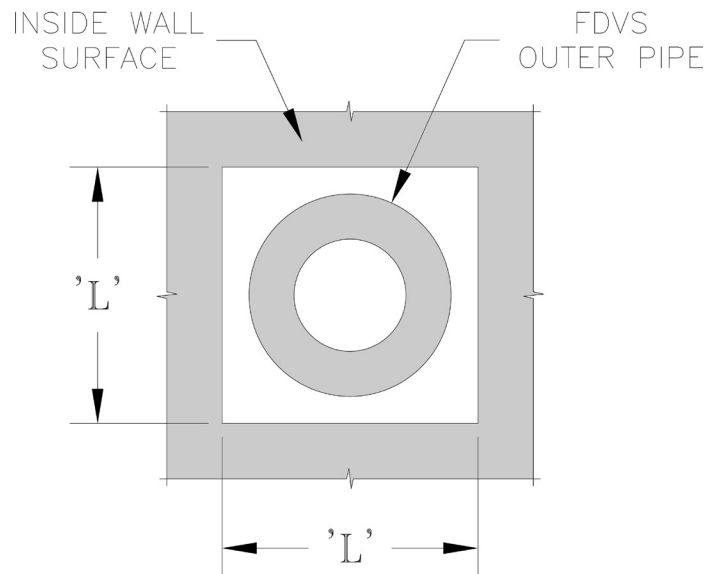

Figure 5-3: Wall Cutout Dimensions

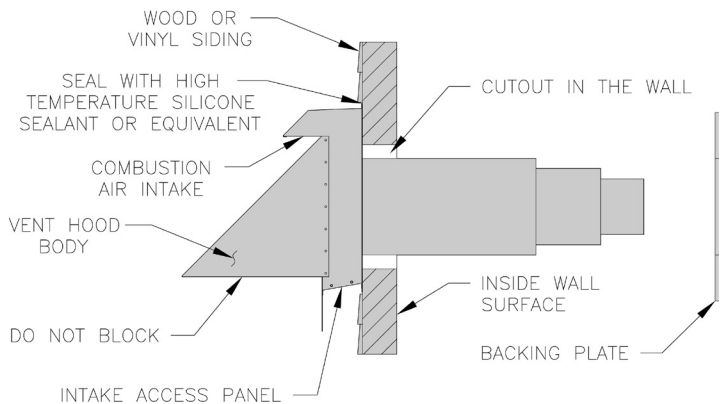

Figure 5-4: Vent Hood Body Installation

5 Direct Venting / Air Intake Piping (continued)

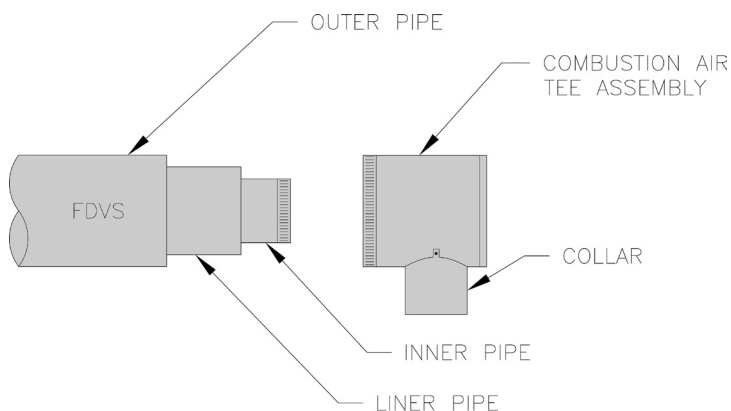

Figure 5-5: Combustion Air Tee Assembly Installation

C. INSTALLATION OF VENT HOOD TEE

1. Assemble the vent hood tee body to the vent hood outer pipe, and, rotate the tee, so air intake inlet collar is in the desired position. See Figure 5-5.
2. Attach the vent hood tee body to the vent hood outer pipe with at least three sheet metal screws (installer provided).

Note: The tee may be rotated into any position so that the collar is in a convenient orientation.

3. After completing assembly of the flexible double wall insulated vent pipe to the vent termination inner pipe (see Figure 5-6 and the following Steps), apply the supplied high temperature sealant to seal around the inner pipe protrusion thru the vent tee cover pan, around the joint between the vent tee collar and the vent tee body, and, seal or tape the joint between the vent termination outer pipe and the vent tee body.

D. INSTALLING THE FLEX OIL VENT PIPE FROM THE VENT TERMINATION TO THE BOILER FLUE OUTLET

1. The venting system (vent pipe and all connectors) shall be installed in accordance with the applicable provisions of any local codes, and, in United States, requirements of NFPA 31- *Standard for the Installation of Oil-Burning Equipment* and NFPA 211 *Standard for Chimney, Fireplaces, Vents and Solid Fuel-Burning Appliances*, latest editions. For installations in Canada, follow requirements of CSA B139 - *Installation Code for Oil Burning Equipment*, latest edition.
2. A vent pipe connector, designed for positive pressure venting, shall be supported for the design and weight of material employed, to maintain clearances, prevent physical damage and separation of joints. All joints **MUST BE** sealed, for positive vent pressure, to prevent flue gas leakage into the structure.
3. Support the vent pipe at intervals no greater than three (3) feet apart using perforated metal strap or other non-combustible supports.
4. Allow sealant to cure at least one hour before firing boiler.
5. Route the vent pipe from the vent termination to the boiler using the minimum number of bends possible. The last horizontal section of the vent pipe should have a slight downward slope from the boiler to the vent termination. For clearances to combustible materials refer to Figure 1-5.
6. Maximum length of flexible oil vent pipe is 20 ft. The vent pipe is also available in 10 ft. length.
7. Verify that flex vent pipe diameter and vent termination inner pipe diameter correspond to a particular direct vent configuration EMP boiler model (see Table 5-7).

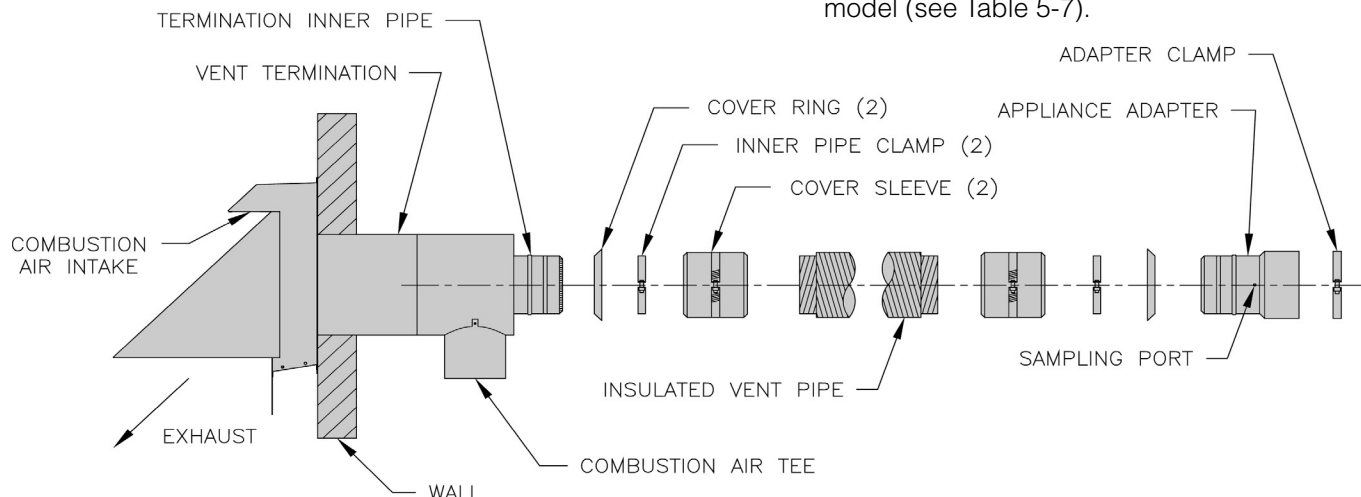

Figure 5-6: FDVS Component Breakdown

5 Direct Venting / Air Intake Piping *(continued)*

Table 5-7: Flex Vent / Vent Termination Pipe Diameters

Boiler Model No.	Boiler Flue Outlet Collar OD (Inch)	Vent Hood Inner Pipe Diameter (Inch)	Flex Oil Vent Pipe Inner Pipe Diameter (Inch)	* Flue Outlet Collar to Vent Pipe Adapter (Inch)
EMP140E	6	5	5	6 to 5
EMP182E				
EMP224E	7	6	6	7 to 6

NOTE: * The model specific Direct Vent (FDVS) Kit Cartons contain adapters (reducers) (see Table 5-7) to connect boiler flue outlet collar to vent pipe.

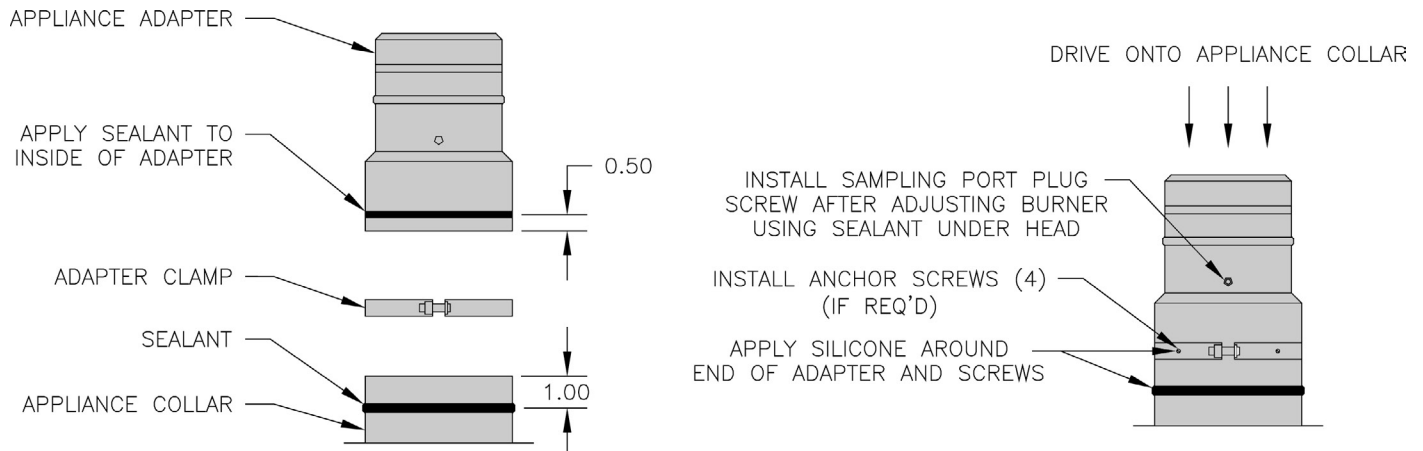

Figure 5-8: Appliance Adapter Installation

E. CONNECTING APPLIANCE ADAPTER TO BOILER FLUE OUTLET COLLAR

(See Figure 5-8)

1. Apply a bead of supplied high temperature sealant to boiler flue outlet collar approximately 1 in. from collar end.
2. Remove any oil and grease from inside of supplied Appliance (Boiler Flue Outlet) Adapter, and, apply a bead of high temperature sealant to inside of the adapter, ½ in. from end.
3. With twisting motion, assemble the appliance adapter onto boiler flue outlet collar.
4. Using a mallet and a block of wood, carefully tap the adapter onto the outlet collar. Insure no damage is done to the adapter and the flue outlet collar.
5. Assemble supplied adapter clamp halves with 5/16-18 bolts and square nuts; install the adapter clamp onto the appliance adapter and tighten securely.
6. If required, install anchoring screws (installer provided) thru four holes in the clamp into the flue outlet collar.
7. Apply sealant around the adapter end mated to the flue outlet collar.
8. Install supplied 3/8 in. sampling port plug screw hand tight into the adapter sampling port.

9. After initial boiler start-up and burner testing/adjustment are completed, apply high temperature sealant under the head of sampling port plug screw, and, install the screw in the sampling port tightening securely.

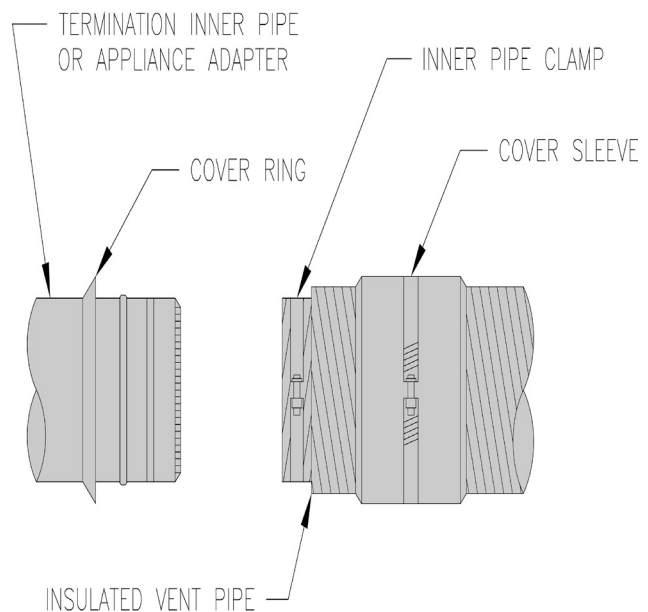

Figure 5-9: Vent Pipe Assembly to Vent Termination Inner Pipe and Appliance Adapter

5 Direct Venting / Air Intake Piping *(continued)*

F. CONNECTING FLEX OIL VENT PIPE TO APPLIANCE ADAPTER AND DIRECT VENT TERMINATION

1. Flexible double wall oil vent pipe is available pre-cut 10 ft. and 20 ft. long. If necessary, the vent pipe may be cut to required length with a hacksaw or cutoff saw.

⚠ CAUTION

Use safety glasses and other appropriated safety gear when cutting the vent pipe.

2. The double wall flexible vent pipe consists of the smaller inner corrugated stainless steel pipe and larger corrugated aluminum pipe, separated by fiberglass insulation layer.

⚠ CAUTION

The inner and outer pipe ends may have sharp burrs. Use gloves, while handling, compressing or expanding the vent pipe.

3. Pull outer vent pipe back 1 in. to 2 in. from end of inner vent pipe and remove insulation; firstly, at vent pipe end to be connected to the vent termination; secondly, at vent pipe end to be connected to the appliance adapter. See Figure 5-9.
4. Install supplied Cover Sleeve Assembly onto each end of outer vent pipe, and, move the assembly a few inches back from the end; firstly, at vent pipe side to be connected to the vent termination; secondly, at vent pipe side to be connected to the appliance (boiler outlet collar) adapter. See Figure 5-9.
5. Slide supplied Cover Rings; firstly, over stop bead on vent termination inner pipe; secondly, over stop bead on appliance adapter. See Figure 5-9.

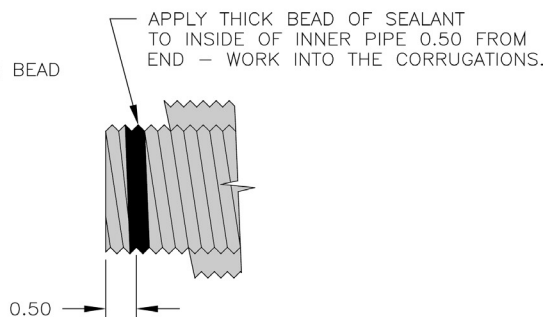
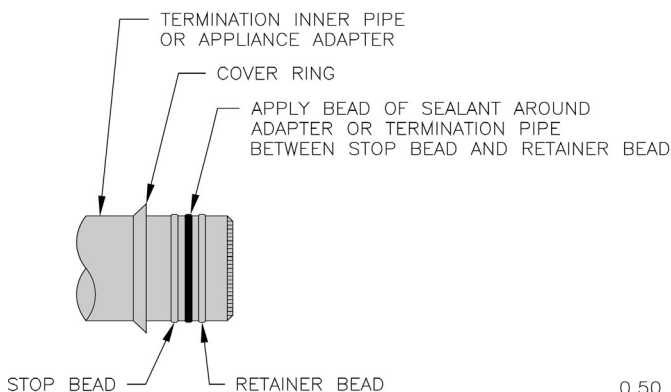

Figure 5-10: Vent Pipe Ends, Vent Termination and Appliance Adapter Sealing

6. Remove any oil and grease from the end of vent termination inner pipe, and, from the end of the appliance adapter.
7. Apply sealant; firstly, between the stop bead and retainer bead at the end of the vent termination inner pipe; secondly, between the stop bead and retainer bead at the end of the appliance adapter. See Figure 5-10.
8. Assemble supplied inner pipe clamp halves with 1/4-20 bolts and square nuts; position the inner pipe clamps 1/4 in. from the end of inner vent pipe, on vent pipe opposite ends.
9. Remove any oil and grease from inside of each end of the inner vent pipe.
10. Apply a thick bead of sealant to inside of each end of the inner vent pipe, 1/2 in. from pipe end, working the sealant into the inner vent pipe corrugations. See Figure 5-10.
11. Firstly, push one end of the inner vent pipe onto the vent termination inner pipe, all the way up to the stop bead. Secondly, push the opposite end of the inner vent pipe onto the appliance adapter, all the way up to the stop bead.
12. Tighten the inner pipe clamp bolts at both vent pipe ends, until clamp halves are within 1/8 in. apart. See Figure 5-11.
13. Starting with vent termination end, slide the cover sleeve assembly and the cover ring together to engage the ring in the groove of the sleeve, then, tighten the built-in cover sleeve clamp. Repeat above steps at the boiler end. See Figure 5-11.
14. If the appliance collar is within less than 18 in. of combustible material, wrap minimum 1-1/2 in. thick fiberglass insulation (installer provided).
15. To maintain vent pipe 1 in. clearance to combustible material, wrap minimum 1-1/2 in. thick fiberglass insulation (installer provided) around the exposed portion of the vent termination inner pipe and secure with adhesive-backed aluminum foil tape (installer provided).

5 Direct Venting / Air Intake Piping (continued)

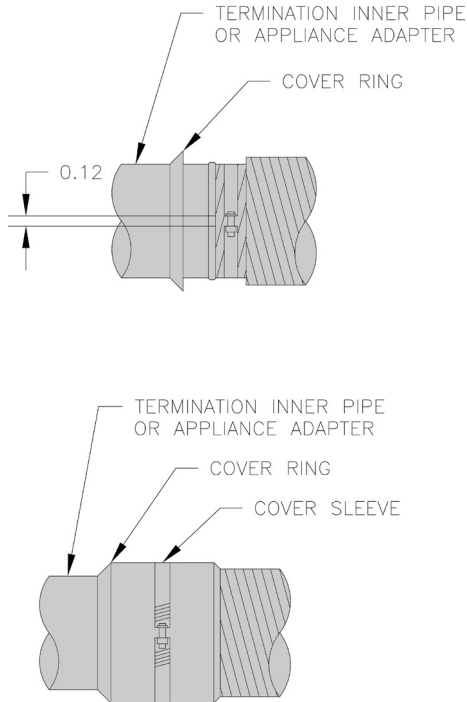

Figure 5-11: Vent Pipe Assembly to Vent Termination Inner Pipe & Appliance Adapter

G. INSTALLING THE AIR INTAKE PIPING FROM DIRECT VENT TERMINATION TO BURNER OUTSIDE AIR ADAPTER

1. Use 4 in. diameter galvanized single wall vent pipe and fittings, available at most heating distributors, to connect burner outside air adapter to Direct Vent Termination air intake collar.
2. Maximum air intake pipe length is 40 equivalent feet.

WARNING

DO NOT reduce size of air intake pipe.

3. Start at burner and work towards Direct Vent termination.
4. Remove burner cover. Loosen two screws securing outside air duct bracket to burner cover mounting plate. See Figure 5-12.
5. Procure a 2-ft. section of 4 in. diameter galvanized single wall vent pipe, cut off the crimped pipe end below stop bead.
6. Insert one end of the vent pipe thru the outside air duct bracket opening and firmly push onto the outside air adapter collar.
7. Secure the pipe to collar with at least (3) sheet metal screws (installer provided) evenly spaced around the collar.
8. Re-tighten the screws securing outside air duct bracket to burner cover mounting plate.

NOTICE: It is essential to ensure reliable operation that combustion air joints are air tight and that VRV is located as close to the burner as possible.

9. Install supplied vacuum relief valve tee assembly, crimped end down, into the opposite end of vent pipe.
10. Secure the tee to the pipe with at least (3) sheet metal screws (installer provided) evenly spaced.
11. Remove the vacuum relief valve gate assembly from the tee.

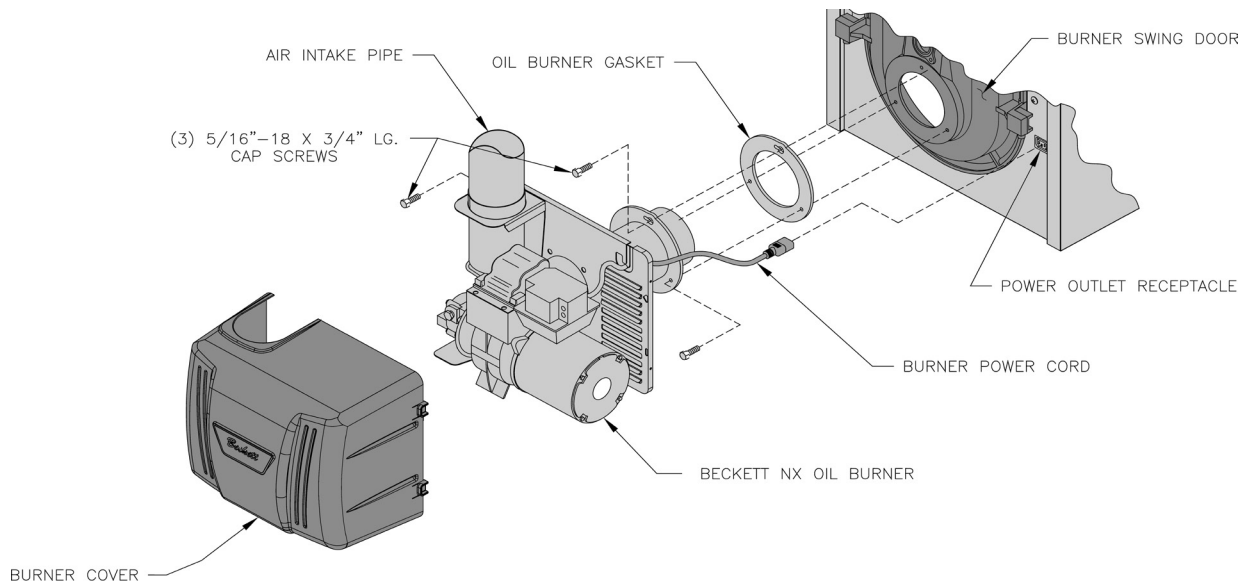

Figure 5-12: Oil Burner Installation (Beckett shown)

5 Direct Venting / Air Intake Piping *(continued)*

12. Assemble the vacuum relief valve balance weight onto the gate. Refer to the vacuum relief valve manufacturer's instructions for details.
13. Mount the assembled vacuum relief valve gate with balance weight into the tee and fasten with a screw and nut in collar tabs. To insure proper operation, the gate must be level across the pivot point and plumb. Refer to the vacuum relief valve manufacturer's instructions for details.
14. Install remainder of air intake piping to Direct Vent Termination air intake collar, securing each joint with at least (3) sheet metal screws (installer provided) evenly spaced.
15. Maintain ¼ in. per foot slope in horizontal run to air intake of Direct Vent Termination.
16. Support the air intake piping, as required, using perforated metal strap or other supports.
17. Refer to Burner Manufacturer's Manual for addition information.

6 Electrical

DANGER

Positively assure all electrical connections are unpowered before attempting installation or service of electrical components or connections of the boiler or building. Lock out all electrical boxes with padlock once power is turned off.

WARNING

Failure to properly wire electrical connections to the boiler may result in serious physical harm.

Electrical power may be from more than one source. Make sure all power is off before attempting any electrical work.

Each boiler must be protected with a properly sized fused disconnect.

Never jump out or make inoperative any safety or operating controls.

A. GENERAL

1. Install wiring and electrically ground boiler in accordance with requirements of the authority having jurisdiction, or in absence of such requirements the *National Electrical Code*, *ANSI/NFPA 70*, and/or the *CSA C22.1 Electric Code*.
2. Refer to National Electric Code or Local Electric Codes for proper size and type of wire required. Follow Code.
3. A separate electrical circuit must be run from the main electrical service with an over-current device/disconnect in the circuit. A service switch is recommended and may be required by some local jurisdictions.
4. Use anti-short bushings on all wiring passing through boiler jacket, junction boxes and/or control boxes.
5. Use armored cable (BX) over all exposed line voltage wiring.
6. If an Alliance™ SL water heater is used, use priority zoning. Do not use priority zoning for Hydro-Air Systems.
7. Wiring should conform to Figures 6-1 or 6-2.

- #### B. INSTALL A ROOM THERMOSTAT
- on an inside wall about four feet above floor. Never install thermostat on an outside wall or where it will be influenced by drafts, hot or cold water pipes, lighting fixtures, television, rays of the sun or near a fireplace. Keep large furniture away from thermostat so there will be free movement of room air around this control.

Heat Anticipator in Thermostat should be set to match the requirements of the control to which it is connected. See Figures 6-1 and 6-2 for desired system and heat anticipator setting. If system tends to overheat above the thermostat's temperature setting, reduce heat anticipator setting by .1 or .2 amps. If system tends to short cycle without reaching desired room temperature, increase heat anticipator setting by .1 or .2 amps.

6 Electrical *(continued)*

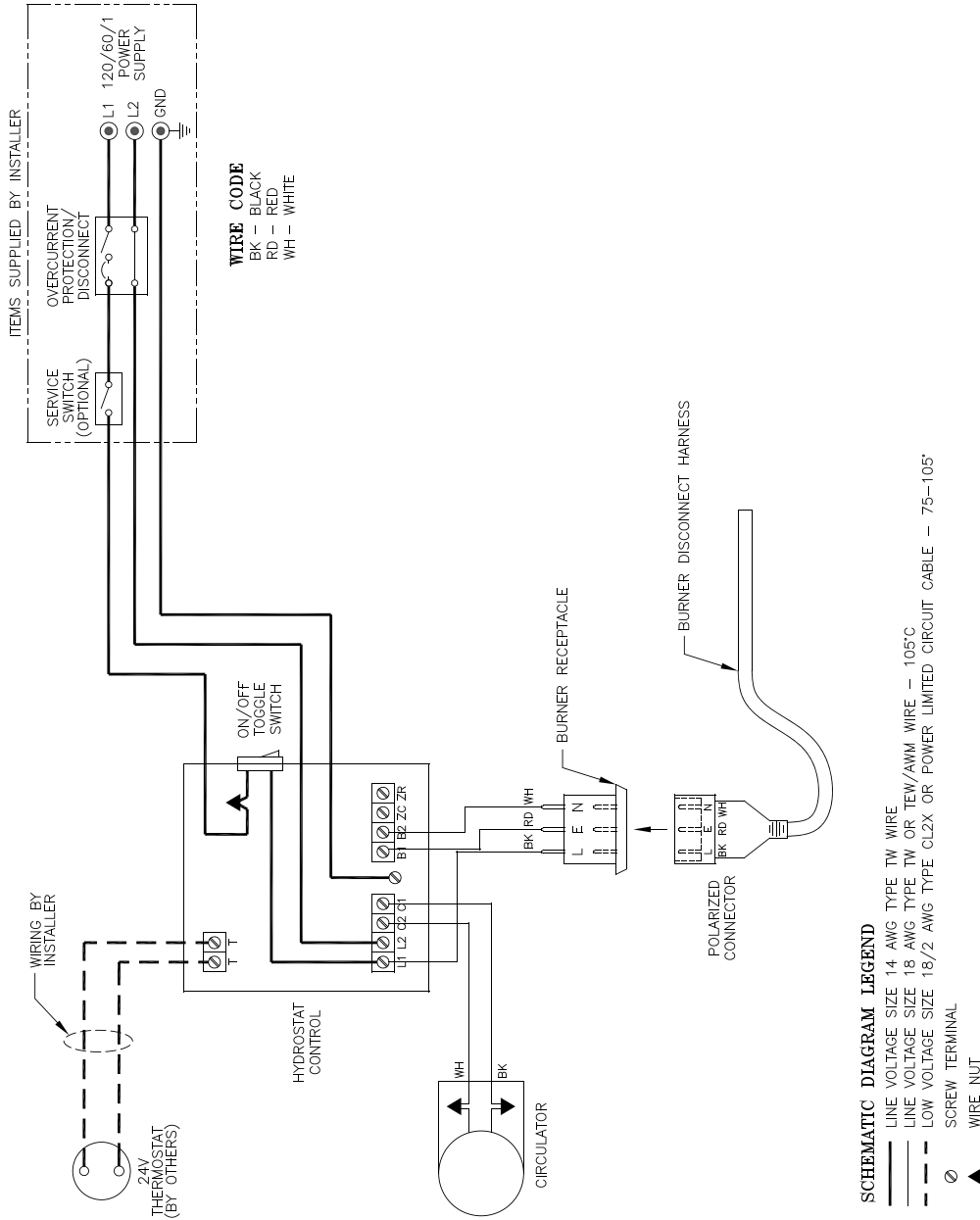
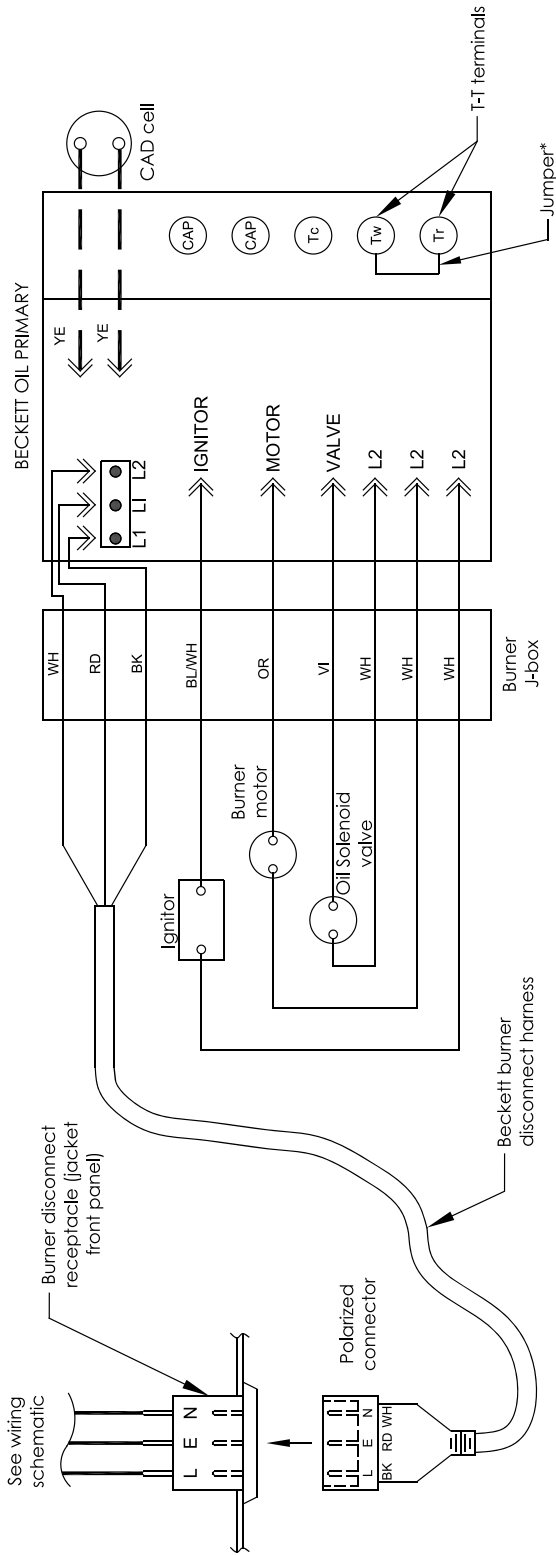

Figure 6-1: Schematic Wiring Diagram

BOILER SEQUENCE OF OPERATION

A call for heat by the thermostat energizes the boiler control which in turn energizes the primary control to turn on the burner. The burner will operate in the following sequence: Pre-purge for the first 10 seconds; fire until the thermostat is satisfied or the limit setting on the operating (high) limit is reached; post-purge for the last 10 seconds. The circulator will operate as long as the thermostat is calling for heat. If the thermostat is not satisfied and the operating (high) limit is reached, the circulator will continue to operate, and the burner will stop until the operating (high) limit is closed by a 15°F drop in boiler water temperature. On burner start, if the cad cell does not see flame within approximately 15 seconds, primary control will shut burner down and enter into a recycle mode, after 60 seconds burner will restart and repeat trial for ignition. If after three (3) trials for ignition, flame is not detected, control will enter into restricted mode and must be reset manually before burner can be restarted.

6 Electrical (continued)



BECKETT AFG BURNER WITH BECKETT 7565 PRIMARY CONTROL

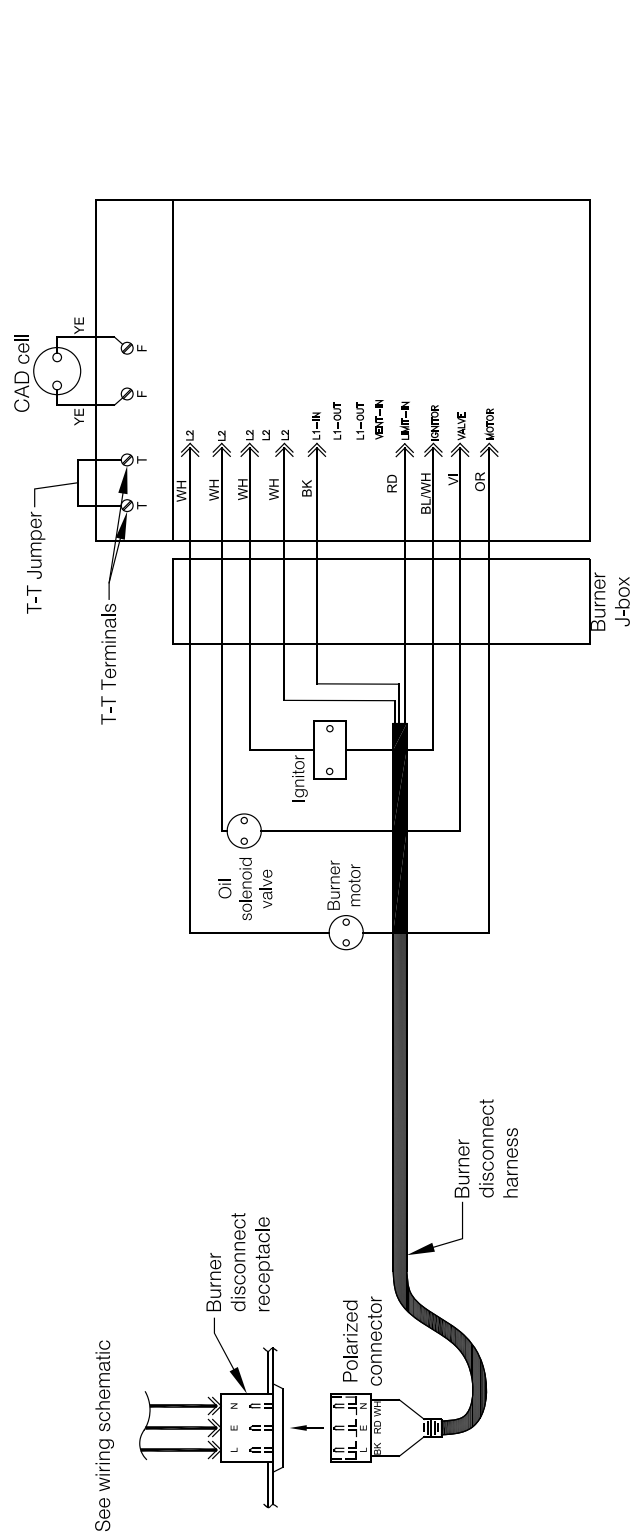

CARLIN EZ1 BURNERS WITH CARLIN 70200 OIL PRIMARY CONTROL

Figure 6-2: Schematic Wing Diagram, Beckett and Carlin

7 Oil Piping

NOTICE: The National Oilheat Research Alliance (NORA) recommends single pipe oil systems and high-quality filtration for all fuel types. This should include at least a 10-micron Spin-on filter. Double filtration provides even greater assurance clean fuel will get to the pump. Contaminants in the tank that enter the fuel supply to the burner can cause pump sticking/seizing. These contaminants may increase in the early stages of transitioning to modern fuels (Ultra Low Sulfur and Bio Blends). High quality filtration adds protection against pump sticking.

A. GENERAL

1. Use flexible oil line(s) so the burner swing door can be opened without disconnecting the oil supply piping.
2. A supply line fuel oil filter is recommended as a minimum for all firing rates but a pleated paper fuel oil filter is recommended for the firing rates below 1.0 GPH to prevent nozzle fouling.
3. Use Flared fittings only. Cast iron fittings cannot be used.

NOTICE: Do not use compression fittings.

Oil piping must be absolutely airtight or leaks or loss of prime may result. Bleed line and fuel unit completely.

Refer to your local jurisdictions regarding any special considerations for fuel supply requirements. In addition, refer to NFPA 31, Standard for the *Installation of Oil-Burning Equipment*.

4. Use of a high efficiency micron filter (Garber or equivalent) in addition to a conventional filter is highly recommended.

5. Piping used to connect the oil burner to the oil supply tank shall not be smaller than 3/8 in. iron pipe or 3/8 in. OD copper tubing. Copper tubing shall have a .032 in. minimum wall thickness.

⚠ WARNING

Under no circumstances can copper with sweat style connectors be used.

NOTICE: Some jurisdictions require the use of a fusible shutoff valve at the tank and/or the burner. In addition, some jurisdictions require the use of a fusible electrical interlock with the burner circuit. Check your local Codes for special requirements.

B. SINGLE PIPE OIL LINES

1. Standard burners are provided with single-stage 3450 RPM fuel units with the bypass plug removed for single-pipe installations.
2. The single-stage fuel unit may be installed single-pipe with gravity feed or lift. Maximum allowable lift is 8 feet. See Figure 7-1.
3. Fuel Oil Line Deaerator – On many occasions a leaky oil delivery line can introduce air into the fuel oil supply system. This often creates a rough starting condition and can create a burner lockout state. In addition to fixing the leak, a fuel line deaerator can be installed to eliminate air. The single line from the fuel tank is connected to the deaerator. The burner pump must be connected to the deaerator as a two pipe system. Follow the oil pump manufacturer's recommendations for conversion to a two pipe system.

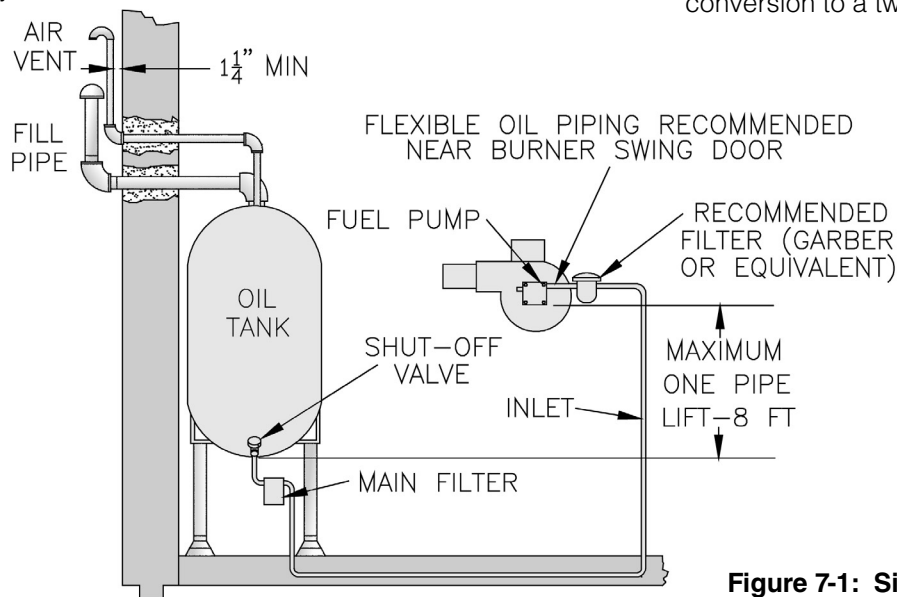

Figure 7-1: Single Pipe Oil Line

7 Oil Piping *(continued)*

C. TWO PIPE OIL LINES

1. For two piped systems, where more lift is required, the two-stage fuel unit is recommended. Table 7-2 (two-stage) and Table 7-3 (single-stage) show allowable lift and lengths of 3/8 inch and 1/2 inch OD tubing for both suction and return lines. Refer to Figure 7-4.
2. Follow the oil pump manufacturer's recommendations on the proper connections for a two pipe system. Some manufacturers require the insertion of a bypass plug.

Table 7-2: Two-Stage Units (3450 RPM) - Two Pipe Systems

Lift "H"	Maximum Length of Tubing "H" + "R" (See Figure 7-4)	
	3/8 in. OD Tubing (3 GPH)	1/2 in. OD Tubing (3 GPH)
0'	93'	100'
2'	85'	100'
4'	77'	100'
6'	69'	100'
8'	69'	100'
10'	52'	100'
12'	44'	100'
14'	36'	100'
16'	27'	100'
18'	---	76'

3. Under no circumstances is a manual shutoff valve to be located on the return line of a two pipe system. Accidental closure of the return line will rupture the oil pump seals.

Table 7-3: Single-Stage Units (3450 RPM) - Two Pipe Systems

Lift "H"	Maximum Length of Tubing "H" + "R" (See Figure 7-4)	
	3/8 in. OD Tubing (3 GPH)	1/2 in. OD Tubing (3 GPH)
0'	84'	100'
1'	78'	100'
2'	73'	100'
3'	68'	100'
4'	63'	100'
5'	57'	100'
6'	52'	100'
7'	47'	100'
8'	42'	100'
9'	36'	100'
10'	31'	76'
11'	26'	100'
12'	21'	83'
13'	---	62'
14'	---	41'

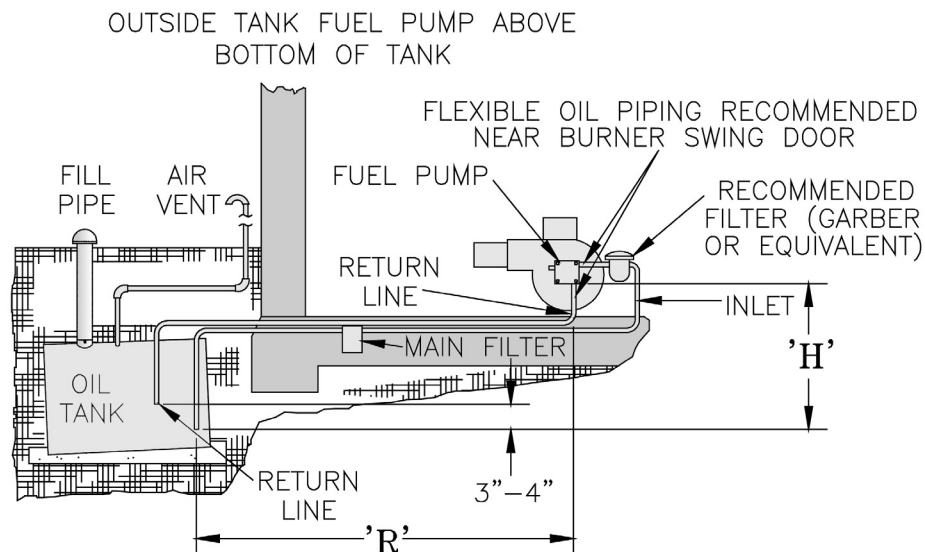

Figure 7-4: Two Pipe Oil Lines

8 System Start-Up

WARNING

All boilers equipped with burner swing door have a potential hazard which can cause severe property damage, personal injury or loss of life if ignored. Before opening swing door, turn off service switch to boiler to prevent accidental firing of burner outside the combustion chamber. Be sure to tighten swing door fastener completely when service is completed. In addition, the burner power cord will have to be disconnected from the receptacle in the front jacket.

A. ALWAYS INSPECT INSTALLATION BEFORE STARTING BURNER.

1. Verify that the venting, water piping, oil piping, and electrical system are installed properly. Refer to Installation Instructions contained in this manual.
2. Confirm all electrical, water and oil supplies are turned off at the source and that the vent is clear from obstructions.

WARNING

Completely read, understand and follow all instructions in this manual before attempting start up.

B. FILL HEATING SYSTEM WITH WATER.

NOTICE: It is important to properly remove the oil and dirt from the system. Failure to clean the system can result in clogged air vents, circulator damage and seized zone valves.

CLEAN HEATING SYSTEM if boiler water is dirty.

Refer to Maintenance and Service Instructions Section of this manual for proper cleaning instructions for water boilers.

1. **HOT WATER BOILERS.** Fill entire heating system with water and vent air from system. Use the following procedure on a series loop or multi-zoned system installed as per Figures 3-2 and 3-3, to remove air from system when filling:
 - a. Close full port ball valve in boiler system piping.
 - b. Isolate all zones by closing zone valves or shut-off valves in supply and return of each zone(s).
 - c. Attach a hose to vertical purge valve in boiler system supply piping up stream from the full port ball valve.
(**Note** - Terminate hose in five gallon bucket at a suitable floor drain or outdoor area).
 - d. Starting with one zone at a time, open zone valve or shut-off valve in boiler supply and return piping.

- e. Open purge valve.
- f. Open shut-off valve in cold water supply piping located between the air scoop and expansion tank.
- g. Allow water to overflow from bucket until discharge from hose is bubble free for 30 seconds.
- h. When zone valve is completely purged of air, close zone valve or shut-off valve. Open zone valve to the next zone to be purged. Repeat this step until all zones have been purged. At completion, open all zone valves.
- i. Close purge valve, continue filling the system until the pressure gauge reads 12 psi. Close shut-off valve in cold water supply piping.

WARNING

The maximum operating pressure of this boiler is posted on the Rating Label located on the top of the boiler. Never exceed this pressure. Do not plug relief valve.

NOTICE: If make-up water line is equipped with pressure reducing valve, system will automatically fill to 12 psi. Follow fill valve manufacturer's instructions.

- j. Open full port ball valve in boiler system piping.
- k. Remove hose from purge valve.
- l. Confirm that the boiler and system have no water leaks.
- m. It may be necessary to clean the air vent assembly after a few days of operation.

C. CHECK CONTROLS, WIRING AND BURNER to be sure that all connections are tight and burner is rigid, that all electrical connections have been completed and fuses installed, and that oil tank is filled and oil lines have been tested.

D. ADJUST CONTROL SETTINGS with burner service switch turned "ON".

1. **SET ROOM THERMOSTAT** about 10°F below room temperature.

8 System Start-Up *(continued)*

2. Press and Hold the ACTION Button on the front of Primary Control for fifteen (15) seconds until the yellow light turns on and release to reset Primary Control.
3. THE BOILER CONTROL is factory set with a High Limit setpoint of 190°F. The High Limit setpoint is adjustable between 100°F and 220°F. This temperature may be varied to suit the installation requirements.
4. CHECKOUT
Put the system into operation and observe at least one complete cycle to make sure that the controller operates properly.

E. CHECK / ADJUST OIL BURNER BEFORE STARTING.

Natural Vent Applications:

1. Check Burner Settings and readjust if necessary, see Burner Specifications, Tables 14-1 and 14-2 at the rear of this manual. Turn off power to burner before proceeding.
2. **Beckett Burners**
 - a. Remove Gun Assembly.
 - b. Verify nozzle size, head size, gun setting, and positioning of electrodes. This information is shown in Figure 8-2, and Beckett AFG Burner Specifications, Table 14-1. Replace Gun Assembly.
 - c. Inspect Beckett head setting on left side of burner housing by insuring the blue line MD(V1) or the line on the label MB(L1) are aligned, readjust if necessary. Refer to Figure 8-2 and Table 14-1 at the rear of this manual.
 - d. Check burner air band and air shutter settings. Readjust if necessary, see Burner Specifications Table 14-1 at the rear of this manual.
 - e. OPEN ALL SHUT-OFF VALVES in the oil supply line to the burner.
 - f. ATTACH A PLASTIC HOSE TO FUEL PUMP VENT/BLEED FITTING and place the other hose end into an empty container to catch the oil.
 - g. SLIGHTLY OPEN FLAME OBSERVATION PORT COVER on burner swing door, enough to insert draft gauge probe later.
3. **Carlin Burners**
 - a. Remove nozzle line electrode assembly from burner.

- b. Verify the desired nozzle; refer to Table 14-2 at the rear of this manual, for proper nozzle. The nozzle must be securely installed to assure leak free joints between the nozzle and adapter. When installing the nozzle, be careful not to bump or move the burner electrodes.
- c. Reinstall Flame Retention Head on Nozzle Line Electrode Assembly. Make sure the clamp is fully sated against the shoulder on the nozzle adapter before securing.
- d. Loosen and remove the retaining nut and factory installed head bar from side of burner housing. Install the proper head bar that corresponds to the desired firing rate, refer to Figure 3-3, and tighten retaining nut.
- e. Readjust air band to preliminary setting that corresponds to the nozzle installed, refer to Figure 3-3. Inspect and measure burner electrodes. Refer to Figure 8-1 for proper electrode setting. Readjust electrode setting to the proper dimensions if necessary.

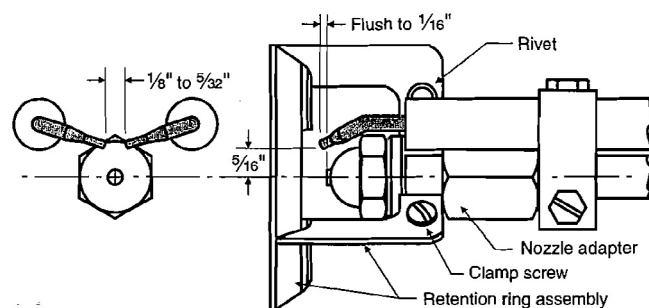

Figure 8-1: Electrode Settings

- f. Reinstall nozzle line electrode assembly.
- g. Reconnect copper connector tube. Tighten knurled nut. Close igniter, rotate and tighten two (2) igniter latching screws.
- h. Inspect Carlin head setting on left side of burner to ensure that the proper head positioning bar matches the nozzle that is installed in drawer assembly refer to Figure 3-3.

Direct Vent Applications:

4. Beckett NX Burners

- a. Verify nozzle size, gun setting and positioning of electrodes. See Figures 8-3 through 8-5 and Beckett NX Burner Specifications, Table 14-3 at the rear of this manual.
- b. Remove burner cover by loosening the four thumb screws and set aside.

8 System Start-Up (continued)

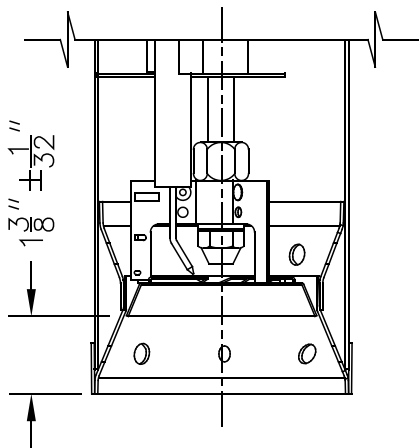

L1 HEAD

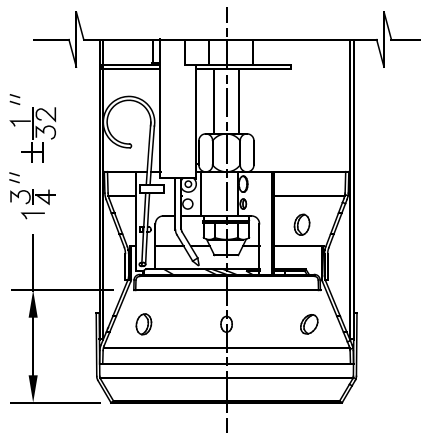

V1 HEAD

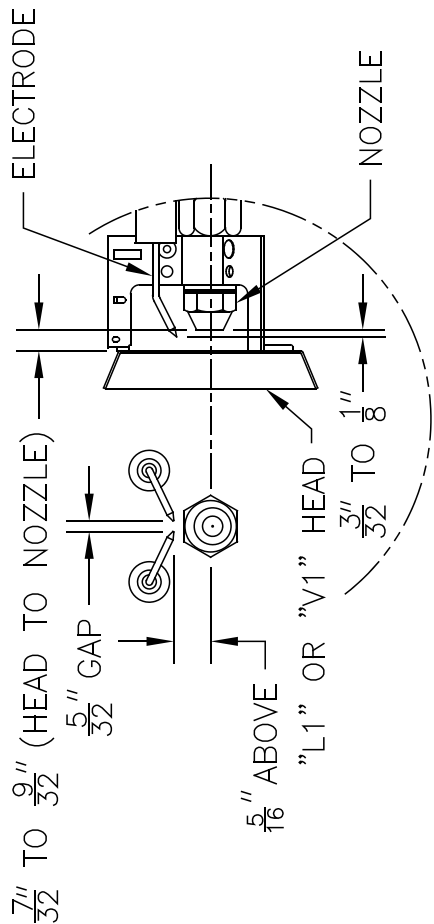

ELECTRODE ADJUSTMENT
"L1" OR "V1" HEAD

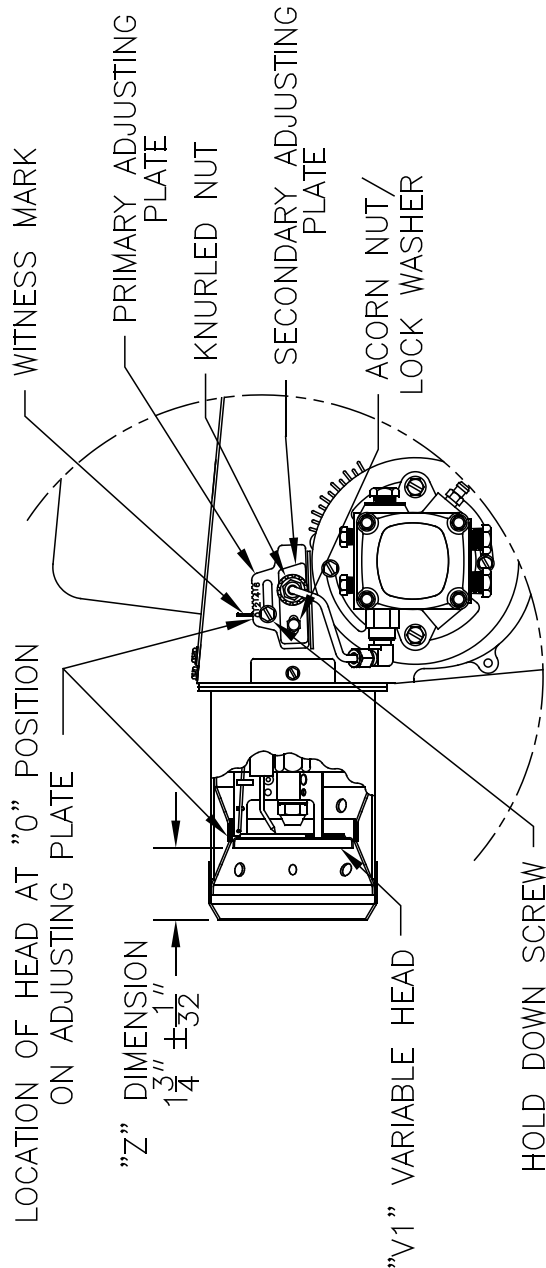

HEAD SETTING (AT "0")
"V1" HEAD

Figure 8-2: "L1" and "V1" Head Electrode Positioning and Gun Setting (Beckett AFG)

8 System Start-Up *(continued)*

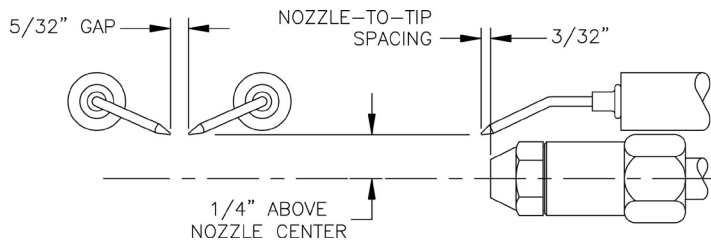

Figure 8-3: Electrode Tip Gap and Spacing

- c. Disconnect the copper oil connector tube from nozzle line.
- d. Loosen the two screws securing igniter-retaining clips and rotate both clips to release the igniter baseplate. The igniter should pop-up and would be supported by the prop spring.
- e. Loosen the two screws securing the rear door, then swing to the right and down.
- f. Loosen splined nut.
- g. Lift up the igniter baseplate and simultaneously remove nozzle line assembly from burner by drawing it straight back out the rear door opening. Be careful not to damage the electrodes or insulators while handling.
- h. Check electrodes to comply with dimensions shown in Figure 8-3. For adjustment, loosen the electrode clamp screw and slide /rotate electrodes as needed. Securely re-tighten the clamp screw when finished.
- i. Check retention head alignment. Cad cell sighting holes in the throttle cup and retention head must line up, so the cad cell can see the flame. Make sure that the "stamped key" in the retention head collar lines up with the "keyway" in the nozzle adapter, when mounting the retention head. See Figure 8-4.
- j. To re-install the nozzle line assembly, reverse procedure outlines in steps f thru b.
- k. Upon reinstallation of the nozzle line assembly, check that head/air plate setting number pointer line up with a number on the scale,

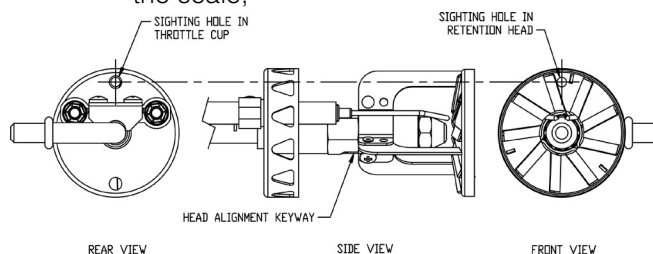

Figure 8-4: Retention Head/Throttle Cup Alignment

which matches a value shown in Table 14-3 for a particular boiler/burner model.

The zero calibration has been factory set; the upper left acorn nut locks retention head at "0" position. If the zero calibration has to be reset, follow the adjustment procedure, outlined at "Prepare Burner & Site" section of Beckett Model NX Oil Burner Instruction Manual, Form Number 610BNX. Make sure the retention head is securely against the stops in the retention ring, when the adjustment plate pointer is at "0".

- l. The rear door must be kept tightly closed upon reinstallation of the nozzle line assembly.
- m. Loosening the splined nut and lower acorn nut, and, turning the adjustment screw, either forward or, rearwards, will adjust the head/air plate. **DO NOT LOOSEN UPPER LEFT ACORN NUT**, which locks zero head/air setting. See Figure 8-5.
- n. **OPEN ALL SHUT-OFF VALVES** in the oil supply line to the burner.
- o. **ATTACH A PLASTIC HOSE TO FUEL PUMP VENT/BLEED FITTING** and place the other hose end into an empty container to catch the oil.
- p. **SLIGHTLY OPEN FLAME OBSERVATION PORT COVER** on burner swing door, enough to insert draft gauge probe later.

WARNING

Very hot flue gases come out of flame observation port cover hole when boiler is operated with port cover open. Always wear proper eye protection.

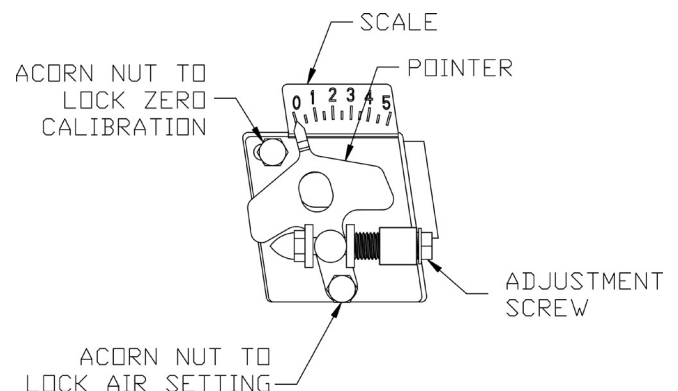

Figure 8-5: Head/Air Adjustment Plate Assembly

8 System Start-Up *(continued)*

F. START OIL BURNER.

1. Open vent fitting on fuel pump.
2. PRESS RED RESET BUTTON on primary control, hold for ten (10) seconds and release to reset primary control.
3. TURN 'ON' BURNER service switch and allow burner to run until oil flows from vent fitting in a SOLID stream without air bubbles for approximately 10 seconds.

NOTE: For Primary Control "Pump Priming Cycle" details, see Paragraph I, No. 2., Step a., Item *ii*.

4. Close vent fitting and burner flame should start immediately after prepurge is completed. Prepurge prevents burner flame until 15 seconds has elapsed after initial power is applied to burner. During prepurge the motor and igniter will operate but the oil valve will remain closed. Refer to Oil Primary Control Instructions for more details.
5. Adjust oil pressure.
 - a. When checking a fuel unit's operating pressure, a reliable pressure gauge may be installed in either the bleeder port or the nozzle port. For Beckett burner refer to Figure 8-6.
 - b. Locate oil pressure adjusting screw and turn screw to obtain proper pump pressure, refer to Tables 14-1 thru 14-3 at the rear of this manual.
 - c. To check the cut-off pressure, deadhead a reliable pressure gauge onto the copper connector tube attached to the nozzle port.

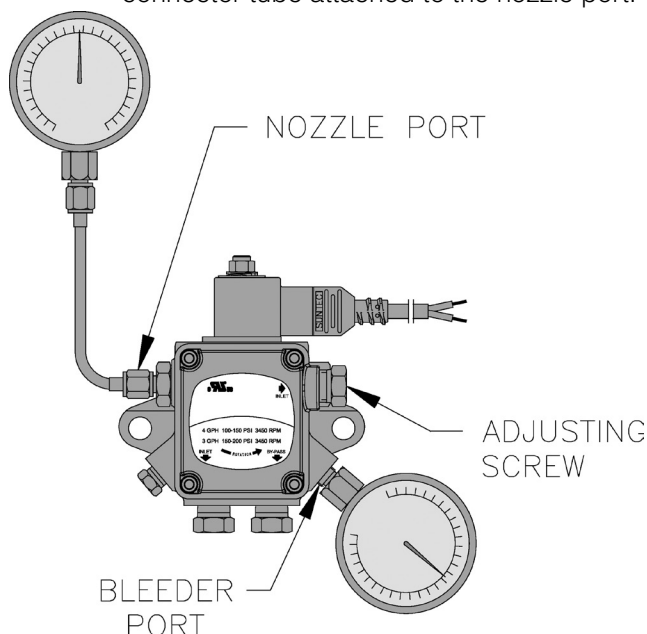

Figure 8-6: Adjusting Fuel Pump Pressure

Run the burner for a short period of time. Shut the burner off. The pressure should drop and hold.

- d. Turn "OFF" the burner. Remove the pressure gauge and install port/bleeder plug and/or reconnect the nozzle port line and tighten. Start the burner again.

G. ADJUST OIL BURNER WHILE OPERATING. (flame present)

1. ADJUST DRAFT REGULATOR (Natural Draft only) for a draft of zero inches (water gauge) in the canopy (see Figure 5-4) after chimney has reached operating temperature and while burner is running. (At least five minutes) See Tables 14-1 thru 14-3 at the rear of this manual for additional details.
2. READJUST THE AIR DAMPER SETTING (Air Band/Air Shutter/Air Gate) on burner for a light orange colored flame while the draft in the canopy is zero inches water column ("w.c."). Use a smoke tester and adjust air for minimum smoke (not to exceed #1) with a minimum of excess air. Make final check using suitable instrumentation to obtain a CO₂ of 11.5 to 13.0% with draft of zero inches water column ("w.c.") (water gauge) in canopy. These settings will assure a safe and efficient operating condition. If the flame appears stringy instead of a solid fire, try another nozzle of the same type. Flame should be solid and compact. After all adjustments are made recheck for a draft of zero inches water column ("w.c.") in the canopy. Replace plug at completion.

See Tables 14-1 thru 14-3 (at the rear of this manual) for details regarding the overfire pressure when baffles are both installed and removed.

NOTE: Paragraph G, Step 1 **MUST BE** repeated every time the Air Damper Setting is readjusted.

3. ONLY READJUST THE HEAD / TURBULATOR SETTING, if necessary.

Beckett AFG Burners

- a. EMP84E thru EMP140E:
Beckett MB(L1 & L2) Head burners have a fixed head which are non-adjustable.
- b. EMP182E thru EMP336E:
Beckett MD(V1) (variable) Head burners have the ability to control air by moving the head. It might be necessary to move the head forward or back one position at a time to optimize the smoke and CO₂ readings. See Figure 8-2.

8 System Start-Up *(continued)*

Beckett NX Burners

- a. Move the Head/Air Setting forward or back one position at a time to optimize the smoke and CO₂ readings. See Figure 8-5.

NOTE: Step outlined in Paragraph G, Steps 1 and 2 above **MUST BE** repeated every time the Head/Turbulator or air Damper Setting is readjusted.

H. CHECK FOR CLEAN CUT OFF OF BURNER.

1. AIR IN THE OIL LINE between fuel unit and nozzle will compress when burner is on and will expand when burner stops, causing oil to squirt from nozzle at low pressure as burner slows down and causing nozzle to drip after burner stops. Usually cycling the burner operation about 5 to 10 times will rid oil line of this air.
2. IF NOZZLE CONTINUES TO DRIP, repeat Paragraph H, Step 1 above. If this does not stop the dripping, remove cut-off valve and seat, and wipe both with a clean cloth until clean, then replace and readjust oil pressure. If dripping or after burn persist replace fuel pump.

I. TEST CONTROLS.

1. Check thermostat operation. Raise and lower thermostat setting as required to start and stop burner.

WARNING

Before installation of the boiler is considered complete, the operation of all boiler controls must be checked, particularly the primary control and high limit control.

- J. Verify Oil Primary Control Features using procedures outlined in Instructions furnished with control or instructions as follows:

1. Priming the pump:
 - a. Prepare the burner for priming by attaching a clear plastic hose over the bleed port fitting and fully opening the pump bleed port. Use a suitable container to collect purged oil.
 - b. Initiate a call for heat.
 - c. After the burner starts, press and hold the ACTION button for 15 seconds until the yellow light turns on. This indicates that the button has been held long enough.
 - d. Release the ACTION button. The yellow light will turn off and the burner will start up again.

- e. At burner starts up, click the ACTION button while the igniter is still on. This will transition the control to a dedicated Pump Prime mode, during which the motor, igniter, and valve are powered for four minutes. The SYS light will be solid yellow for the duration of Pump Prime mode.
 - f. Bleed the pump until all froth and bubbles are purged. If desired, terminate the call for heat or hold the ACTION button for at least one second to exit Pump Prime mode and return to Standby.
 - g. At the end of 4 minutes, SYS light will turn from yellow to green and the control will automatically return to standby mode.
 - h. If prime is not established during the four-minute pump prime mode, return to step 5 to re-enter Pump Prime mode. Repeat steps 5 through 7 until the pump is fully primed and the oil is free of bubbles.
 - i. Terminate the call for heat, and the control will resume normal operation.
2. Safe Start Check
 - a. Place a jumper across the cad cell terminals.
 - b. Initiate a call for heat.
 - c. Burner must not start. Verify that the SYS light is green, FLM light is yellow, and that the control remains in Standby mode.
 - d. End the call for heat and remove the cad cell jumper.
 3. Simulate Flame Failure and Ignition Failure
 - a. Initiate a call for heat.
 - b. After the flame is established and the burner igniter turns off, close the hand valve in the oil supply line.
 - c. At flame loss, the control will enter Recycle mode. Verify that the SYS light is flashing yellow. The control will remain in Recycle for 60 seconds.
 - d. After the 60 second recycle period, the control will try to restart the system.
 - e. After the 15 second lockout time, the control will lock out the burner and the SYS light will flash red. Verify that the burner motor and igniter are off and that the burner oil solenoid valve (if used) is not energized.
 - f. Open the hand valve in the oil line.
 - g. Click the ACTION button and verify that the SYS light shows green and the burner lights.
 - h. End the call for heat.

8 System Start-Up *(continued)*

K. CHECK HIGH LIMIT

1. Adjust system thermostat(s) to highest setting.
2. Allow burner to run until boiler water temperature exceeds high limit setting. The burner should shut down and circulators continue running.
3. Allow the temperature to drop below control setting. The burner must restart.
4. Boiler installation is not considered complete until this check has been made.

L. IF CONTROLS MEET REQUIREMENT outlined in Paragraphs I thru K.

1. Allow boiler to operate for approximately 30 minute, confirm the boiler and system have no leaks.
2. Reset thermostat(s) at desired setting.

M. IF CONTROLS DO NOT MEET REQUIREMENTS outlined in Paragraphs I thru K, replace control and repeat checkout procedures.

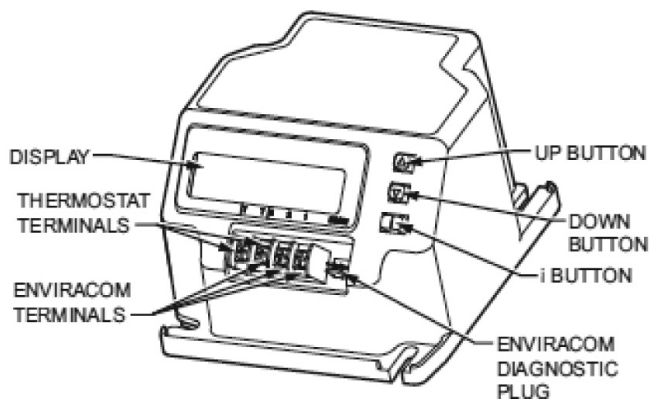

Figure 8-7: R7284 Oil Primary Terminals, Display and Function Buttons

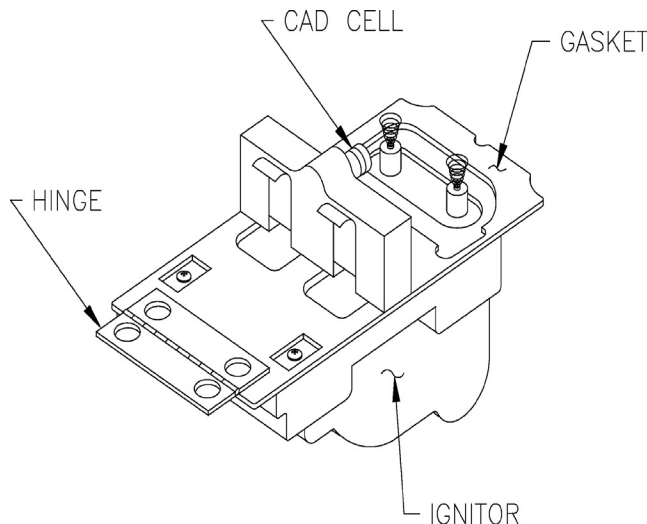

Figure 8-8: Cad Cell Location

9 Operating

- Setting the High Limit:** The high limit is factory set at 190°F. To adjust, turn the HI TEMP Dial A until the desired setting is displayed. (Setting range: 100°-220°F).
- Setting the Low Limit:** The low limit is designed to maintain temperature in boilers equipped with tankless coils used for domestic hot water. The low limit is factory set to OFF. Prior to adjusting, remove the jumper (not equipped on all units) B. Then turn the LP TEMP Dial C clockwise until the desired temperature is displayed. For proper operation, the low temperature limit setting should be least 10° below the high limit setting. **NOTE:** For cold start operation, the low limit must be turned OFF. **IMPORTANT:** If low limit temperature cannot be set above 140°F, remove jumper B. (Setting range: OFF or 110° -200° F).
- Setting the Economy Feature:** The Economy Feature is factory set for a 1 zone heating system. To adjust, turn the ECONOMY Dial D until the number displayed equals the number of heating zones. Do not include indirect water heaters in the number of heating zones. The Economy Feature conserves fuel by reducing boiler temperature (see "How Thermal Targeting Works"). If the heating system is unable to supply needed heat to the house, the ECONOMY Dial should be turned to a lower setting (example: In a three zone house, turn the dial to 2 or 1.) Conversely, if the boiler provides adequate heat, added fuel savings can be achieved by selecting a higher setting (example: 4 or 5). If the heating and indirect water heater signals were not separated when wiring the control, the Economy Feature should be turned OFF to ensure the boiler supplies adequate temperature to heat the indirect tank.

9 Operating *(continued)*

D. Setting the Zone/Indirect Switch: See WIRING.

Setting	
Off	Disables economy function. Will allow boiler to fire until hi-limit temp is reached and re-fire with a 10° subtractive differential
LO	Provides lowest level of fuel savings. Use this setting only if the house does not stay warm at higher settings.
1	Recommended setting for single zone systems
2	Recommended setting for Two zone systems
3	Recommended setting for Three zone systems
4	Recommended setting for Four zone systems
5	Recommended setting for Five zone systems
HI	Provides highest level of fuel savings

E. Optional Features: NOTE: The Program Mode - Pro - is accessed by turning the LP TEMP dial to a position just above OFF.

1. Thermal Pre-Purge: Thermal Pre-Purge is designed to maximize boiler efficiency. When activated, the control will supply latent heat that may remain in the boiler from a previous run cycle to the heating zone that is now calling. The control monitors how quickly the boiler temperature is declining and activates the burner only when it determines that the latent heat is insufficient to satisfy the call. During the purge cycle, the display will indicate Pur. This feature works with single-zone and multi-zone heating systems utilizing circulators or zone valves. No change in wiring is needed.

To activate Thermal Pre-Purge

- a. Turn the LO TEMP dial to access the Program Mode - indicated in the display as Pro.
- b. Turn the HI TEMP dial to select feature 1.
- c. Push the Test/Setting Button to turn Thermal Pre-Purge ON or OFF.
- d. Reset LO TEMP and HI TEMP settings to desired temperatures.

2. Degrees Fahrenheit or Celsius: The control has the ability to operate in degrees Fahrenheit or Celsius. When operating in Celsius, a c will appear in the display next to the temperature whenever the temperature is below 100 degrees.

To change between degrees Fahrenheit and degrees Celsius

- a. Turn the LO TEMP dial to access the Program Mode - indicated in the display as Pro.
- b. Turn the HI TEMP dial to select feature 2.
- c. Push the Test/Setting Button to c for Celsius or F for Fahrenheit.

- d. Reset LO TEMP and HI TEMP settings to desired temperatures.

3. Manual Reset Low Water Cut-Off: The low water cut-off operation on the HydroStat can be set to operate in automatic (default) or manual reset mode. When in manual reset mode, the control will shut-down the burner immediately when low water condition is detected. If the low water condition is sustained for 30 seconds, the low water light will blink, indicating that the control has locked out the burner. The control can only be reset by pushing the Test Settings button on the top of the control. The manual reset feature meets CSD-1 code requirements.

IMPORTANT: The system must be checked by a qualified heating professional prior to resuming operation.

WARNING: DO NOT ADD WATER UNTIL THE BOILER HAS FULLY COOLED.

To activate Manual Reset LWCO mode

- a. Turn the LO TEMP dial to access the Program Mode - indicated in the display as Pro
- b. Turn the HI TEMP dial to select feature 3
- c. Push the Test/Setting Button to A for Automatic Reset Mode
- d. Reset LO TEMP and HI TEMP settings to desired temperatures.

To Test the Manual Reset Feature: Press and hold the Test/Settings button located on the top of the control for 30 seconds to simulate a low water condition. After 30 seconds, the Low Water light will blink indicating that the control is locked out. To reset the lock-out condition, press the Test/Setting button momentarily.

9 Operating *(continued)*

4. Circulator Activation Options

When in the default mode, the HydroStat activates the circulator (**C1/C2** contacts) on calls to **TT**. The control can be programmed to activate the circulator on calls to **ZC/ZR** in place of, or in addition to **TT**.

To change how the Circulator is activated

a. Turn the LO TEMP dial to access the Program Mode - indicated in the display as Pro.

b. Turn the HI TEMP dial to select feature 4.

c. Push the Test/Setting Button to select between the following options:

A - Circulator on **TT** call only

b - Circulator on **ZC/ZR** calls

C - Circulator on both **TT** & **ZC/ZR** calls

d. Reset LO TEMP and HI TEMP settings to desired temperatures.

5. Circulator Hold Off (Enhanced Condensing Protection)

To reduce the potential for condensing, On a call for heat the control will allow the boiler to heat to 125°F prior to energizing the circulator. Once energized, the circulator will remain on for the duration of the heating call unless the boiler temperature drops below 115°F. If this occurs, the circulator will re-energize when the boiler returns to 125°F. Circulator Hold Off will expire after 15 minutes.

To activate Circulator Hold Off

a. Turn the LO TEMP dial to access the Program Mode - indicated in the display as Pro.

b. Turn the HI TEMP dial to select feature 5.

c. Push the Test/Setting Button to Circulator Hold Off ON or OFF.

d. Reset LO TEMP and HI TEMP settings to desired temperatures.

6. Setting the Well Type (Electro-Well vs. Standard Immersion Well)

When used to replace older temperature-only controls, the HydroStat can be installed on the existing well. (The Hydrolevel Electro-Well is required to activate low water cut-off operation. Older wells may contain hardened heat transfer grease or other contaminants that could interfere with metal-to-metal continually between the sensor head and the inside of the well. Insufficient contact could lead to false low water conditions and burner shut downs. Setting the well type to Standard Well prevents the possibility of this occurring.

To change the well type

a. Turn the LO TEMP dial to access the

Program Mode - indicated in the display as Pro.

b. Turn the HI TEMP dial to select feature 8.

c. Push the Test/Setting Button to select A for Electro-Well or b for Standard Well.

NOTE: To ensure that the low water cut-off is always active when the control is installed on an Electro-Well, setting b will ONLY be available when installed on a standard well. The HydroStat sensor checks to determine if a standard well is used by looking for low resistance to ground, a condition that can only exist with a standard well. If you are installing on a standard well and either Low Water LED's are on, setting b will not be available. Check to see if the inside of the well tube is badly oxidized or contaminated with heat transfer grease. It may be necessary to clean the well to allow for setting b to be selected (See Troubleshooting Guide for more information).

7. High Limit Differential

When the Economy feature is on, the control's Thermal Targeting feature actively sets varying differentials based on system conditions. This option allows for selecting a 10, 20 or 30 degree fixed differential when the Economy feature is turned OFF. These optional differential settings are subtractive from the HIGH LIMIT setting. **Note:** If the Economy feature is on, this setting will be overridden by the control's Thermal Targeting function.

To change the high limit differential

a. Turn the LO TEMP dial to access the Program Mode - indicated in the display as Pro.

b. Turn the HI TEMP dial to select feature 9.

c. Push the Test/Setting Button to select a high limit differential of 10, 20, or 30.

d. Reset LO TEMP and HI TEMP settings to desired temperatures.

8. Restore Factory Default Settings

To restore all features to the factory default settings (see following chart for default settings)

a. Turn the LO TEMP dial to access the Program Mode - indicated in the display as Pro

b. Turn the HI TEMP dial to select feature dEF

c. Push the Test/Setting Button to Y to reset all features to the default settings

d. Reset LO TEMP and HI TEMP settings to desired temperatures.

9 Operating *(continued)*

Dial Setting	Feature	Options	Description	Default Setting
1	Thermal Pre-Purge	OFF ON	Purge Inactive Purge Active	OFF
2	Fahrenheit or Celsius	F C	Degrees Fahrenheit Degree Celsius	F
3	LWCO Manual or Automatic Reset	A b	Automatic Reset Manual Reset	A
4	Circulator Options	A b c	Circulator operation on TT call only Circulator operation on ZC/ZR call only Circulator operation on call from either	A
5	Circulator Hold Off	ON OFF	Circulator Hold Off - Active Circulator Hold Off - Inactive	ON
6	Not available on this control			
7	Not available on this control			
8	Well Type	A b	Hydrolevel Electro-Well Standard Immersion Well	A
9	High Limit Differential	10 20 30	10° Differential 20° Differential 30° Differential	10
dEF	Restore Factory Defaults	Y N	Restore Defaults Do Not Restore Defaults	n

NOTE: If the HydroStat is factory-equipped on a boiler, some options may be set differently from the default settings. Not all features are available on older HydroStat models.

9. LED Legend and Test/Settings Button
 - a. TEMP ACTIVE Indicates that the Fuel Smart HydroStat control is powered and that the temperature function is active.
 - b. TEMP HI TEMP Illuminates when the boiler water temperature reaches the high limit setting. It will remain lit until the water temperature falls 10°. The Fuel Smart HydroStat prevents burner operation while this LED is on. See Differential explanation.
 - c. LWCO ACTIVE Indicates that the low water cut-off (LWCO) function of the Fuel Smart HydroStat is active. When the control is installed with a Hydrolevel Electro-Well™, this LED will be on at all times when the control is powered. **IMPORTANT:** If the control is installed with a well other than the Electro-Well™, this LED will no illuminate indicating that the control is not providing low water cut-off functionality.
 - d. LWCO LOW WATER Indicates that the boiler is in a low water condition. The HydroStat control will prevent burner

operation during this condition. If the LOW WATER light is blinking, the control has been programmed to provide lockout protection in the event a low water condition is detected (see Manual Reset Low Water Cut-Off). Pressing the TEST/SETTINGS button will reset the control.

IMPORTANT: The system must be checked by a qualified heating professional prior to resuming operation.

WARNING

Allow the boiler to fully cool before adding water.

- e. ECONOMY ACTIVE Indicates that the Thermal Targeting function is active and the Fuel Smart HydroStat will reduce boiler temperature to conserve fuel. The Economy feature is activated using the ECONOMY dial. (See “How Thermal Targeting Works” for more information).

9 Operating *(continued)*

- f. **ECONOMY TARGET** When the Economy feature is active, the Fuel Smart HydroStat continually sets target temperature below the high limit setting to maximize fuel efficiency. When the boiler water reaches the target temperature, the LED illuminates and the burner will shut down. The boiler water will continue to circulate and heat the house as long as the thermostat call continues. The LED will stay lit until the boiler temperature drops below the differential set point at which point the boiler will be allowed to fire again. See Differential explanation.

NOTE: This LED illuminates regularly during normal boiler operation.

- g. **7 TEST/TESTING Button**
To Test Low Water Cut-Off: Press and hold the Test/Settings button for 5 seconds. The display will read LCO.

LWCO TEST LCO

The red Low Water light should illuminate and the burner circuit (B1 and B2) should de-energize.

NOTE: The control must be installed with a Hydrolevel Electro-Well™ for low water cut-off functionality.

To View Current Settings: Press and release the Test/Settings Button in short intervals to sequentially display the following settings:

HIGH LIMIT SETTING HL
 ▼
 LOW LIMIT SETTING LL
 ▼
 ECONOMY SETTING ECO
 ▼

CURRENT TARGET TEMPERATURE 000

The display will return to boiler temperature (default) if Test/Settings Button is not pressed for 5 seconds.

F. BECKETT GENISYS 7565 PRIMARY CONTROL

2. Sequence of Operation (See Figure 9-1)

- Standby: The burner is idle, waiting for a call for heat.
- Validate Air: once the motor turns on and is configured, the control will prove air before pre-purge. This feature requires either a pressure switch or a spill switch.
- Valve-On Delay: Pre-Purge, the igniter and motor are on while the control delays turning on the oil solenoid valve for the programmed time. This feature requires either a Beckett Clean-Cut pump or an external valve.
- Trial For Ignition (TFI): If used, the oil solenoid valve is energized. A flame should

be established within the factory set trial for ignition time ("lockout time").

- Ignition Carryover: Once flame is established, the igniter remains on for the configured carryover time delay to ensure flame stability.
- Run: The flame is sustained until the call for heat is satisfied. The burner is then sent to Motor-Off Delay, if applicable, or it is shut down and sent to Standby.
- Motor-Off Delay: Post-Purge, if applicable, the oil solenoid valve is turned off and the control delays turning the motor off for the set motor-off delay time before the control returns to standby.
- Recycle: If the flame is lost or if the pressure or spill switch (if used) open while the burner is firing, the control shuts down the burner, enters a 60 second recycle delay, and repeats the ignition sequence. The control will continue to Recycle each time the flame is lost, until it reaches the configured number 3 max of retries. The control will then go into Lockout instead of Recycle. This feature prevents excessive accumulation of oil in the appliance firing chamber.
- Lockout: The control has shut down for one of the following safety reasons:
 - The trial for ignition (lockout) time expired without flame being established.
 - The cad cell detected flame at the end of the Valve-On Delay state. Flame is lost while the burner is firing and the pre-set time allotment is expired. See "Recycle".
- To reset the control from (soft) lockout click the button 1-second.

NOTE: A recurrence of the above failure modes or a failed welded relay check could cause the control to enter a Hard Lockout state that must be reset only by a qualified service technician. To reset from Hard Lockout, hold the ACTION button for 15 seconds until the SYS light briefly turns from red to yellow.

- Pump Prime: The igniter and motor are on with the oil solenoid valve energized for 4 minutes. During Pump Prime mode, the cad cell is disregarded, allowing the technician to prime the pump without having to jumper the cad cell.

3. Disable Function

- Any time the burner is running, press and hold the ACTION button to disable the burner. The burner will remain off as long as the button is held.

9 Operating *(continued)*

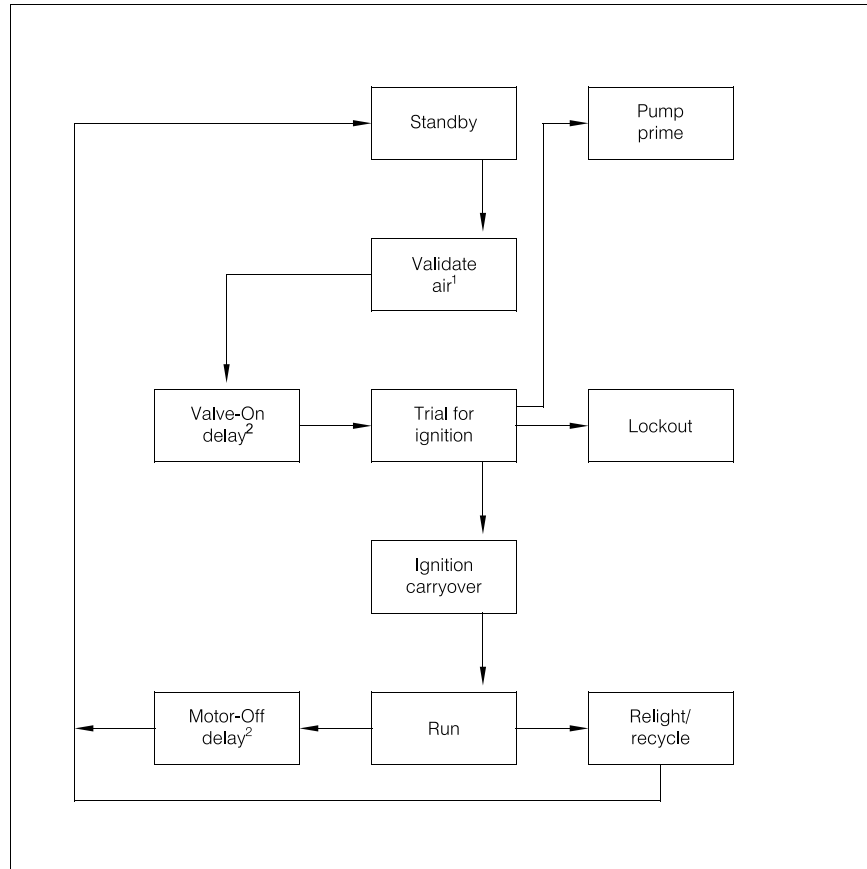

1 = only if air switch is installed
2 = only if valve installed

Figure 9-1: Sequence of Operation, Beckett 7565 Primary Control

2. ACTION Button (See Table 9-2)

Table 9-2: ACTION Button Operation

Burner State/Status	Pressing ACTION Button	Results
Lockout (soft)	1 Second Tap	Reset Control
Lockout (hard)	15+ Seconds	Reset Control
Valve-On Delay, For Ignition or Carryover	1 Second Tap	Go to pump after pump priming is enabled per the next step.
Powered On	15+ Seconds	Enable pump priming, then enters pump prime mode after next ignition sequence.
Any Excerpt Stand By	1+ Seconds	Exits current state and enters Stand-by, then keeps burner off while the button is held.
Powered On	1 Second Tap	Connect to the myTechnician app when prompted.

9 Operating *(continued)*

Important Product Safety Information: Refractory Ceramic Fiber Product

WARNING

Some boiler components use materials that contain refractory ceramic fibers (RCF). RCF has been classified as a possible human carcinogen. When exposed to elevated temperatures, RCF may change into crystalline silica, a known carcinogen. When disturbed as a result of servicing or repair, these substances become airborne and, if inhaled, may be hazardous to your health. Avoid breathing RCF particulates and dust.

Precautionary Measures:

- Do not handle RCF parts or attempt any service or repair work involving RCF without wearing the following protective gear:
 1. A properly fitting National Institute for Occupational Safety and Health (NIOSH)-certified air-purifying respirator with a filter efficiency of at least 95%. Respirator should also include a full facepiece when handling used RCF. Other types of respirators may be required depending on site conditions. Current NIOSH recommendations may be found on the NIOSH website <http://www.cdc.gov/niosh/homepage.html>. NIOSH-approved manufacturers, respirators and associated user instructions are listed on the NIOSH website.
 2. Long sleeved, loose fitting clothing that is sufficiently tight around potential entry points for RCF dust.
 3. Gloves.
 4. Eye protection, such as goggles, safety glasses with side shields, or full facepiece.
- Take steps to assure adequate ventilation.
- Handle RCF carefully to minimize airborne dust. Use hand tools whenever possible.
- Dampen used RCF with light water spray prior to removal to prevent airborne dust.
- Do not use compressed air or dry sweeping for clean-up. Frequently clean work area with a vacuum or by wet sweeping to minimize debris accumulation.
- Vacuum work clothes before leaving work area. Wash work clothes separately from other laundry and rinse washing machine after use to avoid contaminating other clothes.
- Wash all exposed body areas gently with soap and water after contact.
- Discard used RCF components by sealing in an airtight plastic bag or container. Refer to local, regional, state or provincial regulations to identify applicable disposal requirements.

First Aid Procedures:

- Eye contact: Flush with water for at least 15 minutes. **Do not rub eyes.** Seek immediate medical attention if irritation persists.
- Skin contact: Wash affected area gently with soap and water. Do not rub or scratch affected skin. Seek immediate medical attention if irritation persists.
- Nose and throat contact: If these become irritated, leave the area and move to a location with clean fresh air. Drink water and blow nose. Seek immediate medical attention if symptoms persist.

112645-01

10 Maintenance and Service Instructions

A. BOILER AND SYSTEM CLEANING INSTRUCTIONS FOR TROUBLE FREE OPERATION

1. *Filling of Boiler and System — General* — In a hot water heating system, the boiler and entire system (other than the expansion tank) must be full of water for satisfactory operation. Water should be added to the system until the boiler pressure gauge registers 12 psi. To insure that the system is full, water should come out of all air vents when opened.
2. *Boiling Out of Boiler and System.* The oil and grease which accumulate in a new hot water boiler can be washed out in the following manner.
 - a. Ideally, shut off valves have been installed between the boiler return manifold and the rest of the system, to minimize the amount of system draining.
 - b. Drain the boiler to a level below the relief valve tapping.

DANGER

Assure that the boiler is at zero pressure before removing the relief valve. Open the safety valve to relieve all internal pressure prior to proceeding. Safety valve discharge piping must be piped such that the potential for burns is eliminated.

- c. Remove relief valve using extreme care to avoid damaging it.
 - d. Add an appropriate amount of recommended boil out compound.
 - e. Replace relief valve.
 - f. Fill the entire system with water.
 - g. Start firing the boiler.
 - h. Circulate the water through the entire system.
 - i. Vent the system, including the radiation.
 - j. Allow boiler water to reach operating temperature, if possible.
 - k. Continue to circulate the water for a few hours.
 - l. Stop firing the boiler.
 - m. Drain the system in a manner and to a location that hot water can be discharged with safety.
 - n. Remove plugs from all available returns and wash the water side of the boiler as thoroughly as possible, using a high-pressure water stream.
 - o. Refill the system with fresh water.
3. Add appropriate boiler water treatment compounds as recommended by your qualified water treatment company.

4. *Make pH or Alkalinity Test.*

After boiler and system have been cleaned and refilled as previously described, test the pH of the water in the system. This can easily be done by drawing a small sample of boiler water and testing with hydron paper which is used in the same manner as litmus paper, except it gives specific readings. A color chart on the side of the small hydron dispenser gives the reading pH. Hydron paper is inexpensive and obtainable from any chemical supply house or through your local druggist. The pH should be higher than 7 but lower than 11. Add appropriate water treatment chemicals, if necessary, to bring the pH within the specified range. With this lower level of protection, care must be exercised to eliminate all of the free oxygen in the system.

5. Boiler is now ready to be put into service.

B. EXCESSIVE MAKE-UP WATER

A leaky system will increase the volume of make-up water supplied to the boiler which can significantly shorten the life of the boiler. Entrained in make-up water are dissolved minerals, salts and oxygen. When the fresh, cool make-up water is heated in the boiler the minerals fall out as sediment, the salts coat the inside of the boiler, and the oxygen escapes as a gas. The accumulation of sediment eventually isolates the water from contacting the cast iron. When this happens the cast iron in that area gets extremely hot and eventually cracks. The presence of free oxygen or chloride salts in the boiler corrodes the cast iron from the inside. More make-up water and higher concentrations of contaminants damage the boiler sooner. **Our warranty does not cover corrosion and sediment-related damage.** Clearly it is in everyone's best interest to prevent this type of failure. You can do your part by ensuring that your system is leak-free, keeping leakage to less than 2 percent of the boiler water volume each month.

IMPORTANT

IF, DURING NORMAL OPERATION, IT IS NECESSARY TO ADD MORE WATER THAN INDICATED BELOW, CONSULT A QUALIFIED SERVICE TECHNICIAN TO CHECK YOUR SYSTEM FOR LEAKS.

Model No.	Gallons Per Month	Gallons Per Year
EMP84E/115E	0.20	2.4
EMP140E	0.25	3.0
EMP182E	0.30	3.6
EMP224E/EMP280E	0.40	4.8
EMP336E	0.50	6.0

10 Maintenance and Service Instructions *(continued)*

C. ATTENTION TO BOILER WHILE NOT IN OPERATION.

NOTICE: If boiler is not used during winter time, it must be fully drained to prevent freeze damage.

1. Spray inside surfaces with light lubricating or crankcase oil using gun with extended stem so as to reach all corners.
2. Always keep the manual fuel supply valve shut off if the burner is shut down for an extended period of time.
3. To recondition the heating system in the fall season after a prolonged shut down, follow the instructions outlined in Section 8.

WARNING

This boiler contains controls which may cause the boiler to shut down and not restart without service. If damage due to frozen pipes is a possibility, the heating system should not be left unattended in cold weather; or appropriate safeguards and alarms should be installed on the heating system to prevent damage if the boiler is inoperative.

11 Boiler Cleaning

WARNING

All boiler cleaning must be completed with burner service switch turned off. Boilers equipped with burner swing door have a potential hazard which can cause severe property damage, personal injury or loss of life if ignored. Before opening swing door, turn off service switch to boiler to prevent accidental firing of burner outside the combustion chamber. Disconnect the burner plug from the receptacle in the front jacket. Be sure to tighten swing door fastener completely when service is completed.

A. CLEAN THE FLUEWAYS (See Figure 11-1).

1. For access to the combustion chamber remove the two (2) 3/8 in. - 16 cap screws. If boiler is equipped with flexible fuel line(s), swing door open.
2. Remove the two smoke box clean-out covers from the rear smoke box by removing the four 5/16 in. -18 hex head bolts. It is NOT necessary to remove the vent connector from the smoke box to clean boiler.
If necessary, remove the vent connector if there is evidence of heavy soot accumulation in the boiler or to inspect base of chimney for condensate or accumulation of debris.
3. Remove the baffles (if installed) from the flue passages. Refer to Section 2, Paragraph F for Baffle Installation.
4. Clean the 3rd Pass – Insert a 2 in. dia. x 42 in. long wire or fiber bristle brush into each of the two 3rd passes. Using long strokes push the brush all the way through the boiler until the brush has exited the smoke box opening. Pull the brush all the way forward until it has exited the front of the boiler. Continue this operation for the entire height of the flue way until clean. Repeat the operation for the other 3rd pass flue way.
5. Clean the 2nd Pass - Insert a 2 in. dia. x 42 in. long wire or fiber bristle brush into each of the two 2nd passes. Using long strokes push the brush all the way through the boiler until the brush hits the back wall of the reversing chamber. Pull the brush all the way forward until it has exited the front of the boiler. Continue this operation for the entire height of the flue way until clean. Repeat the operation for the other 2nd pass flue way.
6. Vacuum the loose debris in the bottom of the combustion chamber and smoke box.

B. CLEAN THE COMBUSTION CHAMBER – Use a wire or fiber bristle brush to clean the surfaces of the combustion chamber. Vacuum all of the loose debris in the bottom of the combustion chamber.

C. AFTER CLEANING, vacuum all remaining debris as necessary. Inspect burner swing door insulation, and rope gasket for signs of damage. If damaged, replace as needed.

D. REASSEMBLE BOILER.

CAUTION

Do not start the burner unless the burner swing door and canopy cover plates are secured in place.

1. Insert the baffles (if originally installed) into the correct flue way. Refer to Section 2, Paragraph F for Baffle Installation.
2. Attach the smoke box clean-out covers onto the rear of the boiler. Verify that the rope gasket is in good working order before assembly. Replace rope gasket if necessary. Use the 3/8 in. hardware originally removed. Do not over tighten. They should be snug but not bottomed out.

NOTICE: When securing burner swing door make sure door is drawn-in equally on both sides.

Tighten swing door hardware to provide adequate seal to rope gasket around perimeter of door.

Use an alternating tightening method from right side to left side cap screw to pull door tight equally.

NOTICE: Do not overtighten. The rope gasket will provide sufficient seal when the door is snugged into place.

11 Boiler Cleaning *(continued)*

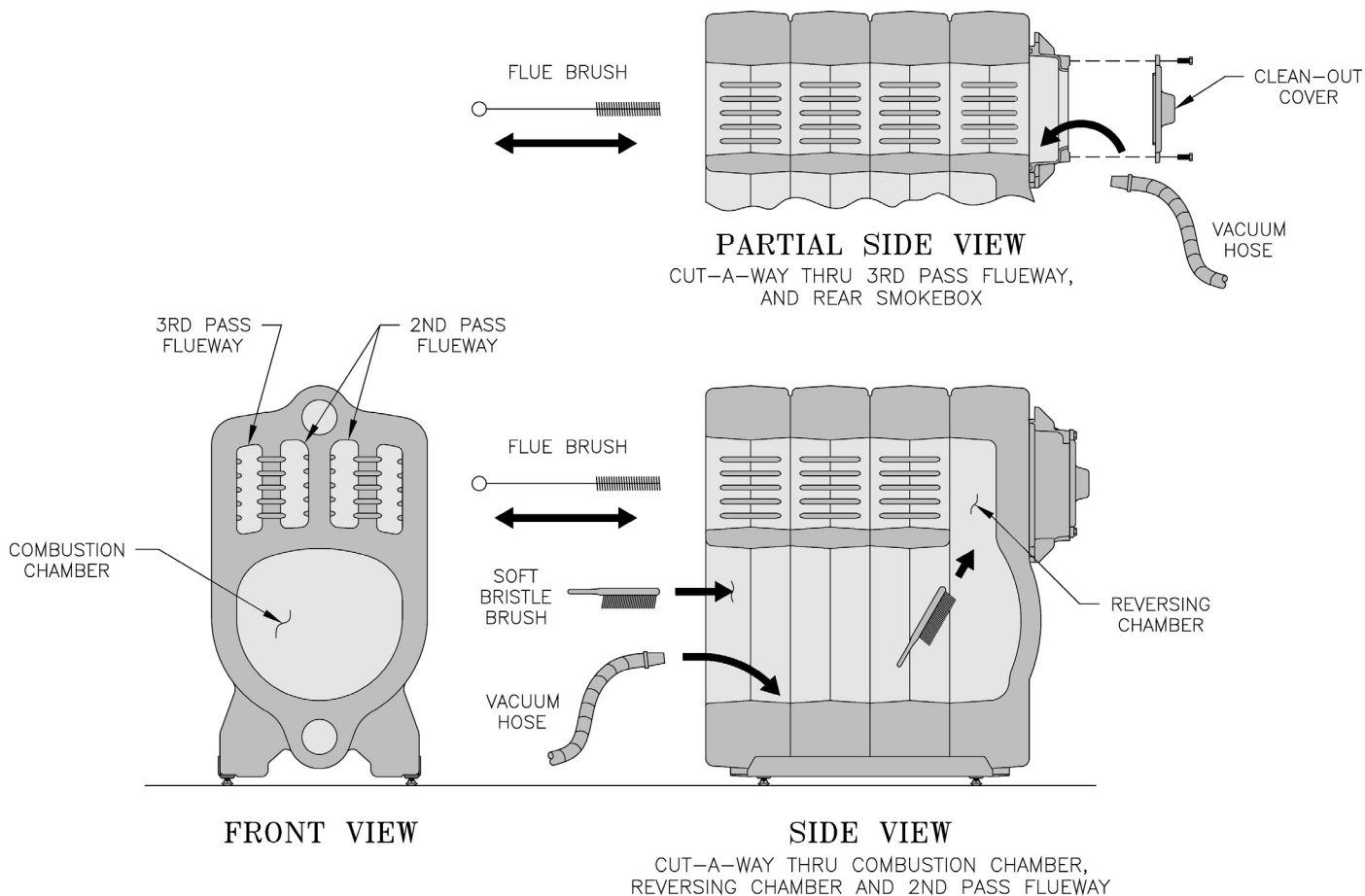

Figure 11-1: Cleaning of Boiler Flueways

⚠ WARNING (Natural Draft Only)

The boiler must be connected to an approved chimney in good condition. Serious property damage could result if the boiler is connected to a dirty or inadequate chimney. The interior of the chimney flue must be inspected and cleaned before the start of the heating season and should be inspected periodically throughout the heating season for any obstructions. A clean and unobstructed chimney flue is necessary to allow noxious fumes that could cause injury or loss of life to vent safely and will contribute toward maintaining the boiler's efficiency.

12 Troubleshooting

A. COMBUSTION

1. **NOZZLES** — Although the nozzle is a relatively inexpensive device, its function is critical to the successful operation of the oil burner. The selection of the nozzle supplied with the EMP boiler is the result of extensive testing to obtain the best flame shape and efficient combustion. Other brands of the same spray angle and spray pattern may be used but may not perform at the expected level of CO₂ and smoke. Nozzles are delicate and should be protected from dirt and abuse. Nozzles are mass-produced and can vary from sample to sample. For all of those reasons a spare nozzle is a desirable item for a serviceman to have.
2. **FLAME SHAPE** — Looking into the combustion chamber through the observation port, the flame should appear straight with no sparklers rolling up toward the crown of the chamber. If the flame drags to the right or left, sends sparklers upward or makes wet spots on the chamber walls, the nozzle should be replaced. If the condition persists look for fuel leaks, air leaks, water or dirt in the fuel as described above.
3. **FUEL LEAKS** — Any fuel leak between the pump and the nozzle will be detrimental to good combustion results. Look for wet surfaces in the air tube, under the ignitor, and around the air inlet. Any such leaks should be repaired as they may cause erratic burning of the fuel and in the extreme case may become a fire hazard.
4. **AIR LEAKS** — Any such leaks should be repaired, as they may cause erratic burning of the fuel and in extreme cases may become a fire hazard.
5. **GASKET LEAKS** — If 11.5 to 12.5% CO₂ with a #1 smoke cannot be obtained in the breeching, look for air leaks around the burner mounting gasket, observation door, and canopy gasket. Such air leaks will cause a lower CO₂ reading in the breeching. The smaller the firing rate the greater effect an air leak can have on CO₂ readings.
6. **DIRT** — A fuel filter is a good investment. Accidental accumulation of dirt in the fuel system can clog the nozzle or nozzle strainer and produce a poor spray pattern from the nozzle. The smaller the firing rate, the smaller the slots become in the nozzle and the more prone to plugging it becomes with the same amount of dirt.
7. **WATER** — Water in the fuel in large amounts will stall the fuel pump. Water in the fuel in smaller amounts will cause excessive wear on the pump, but more importantly water doesn't burn. It chills

the flame and causes smoke and unburned fuel to pass out of the combustion chamber and clog the flueways of the boiler.

8. **COLD OIL** — If the oil temperature approaching the fuel pump is 40°F or lower, poor combustion or delayed ignition may result. Cold oil is harder to atomize at the nozzle. Thus, the spray droplets get larger and the flame shape gets longer. An outside fuel tank that is above grade or has fuel lines in a shallow bury is a good candidate for cold oil. The best solution is to locate the tank near the boiler in the basement utility room or bury the tank and lines deep enough to keep the oil above 40°F. Check environmental issues with local authorities having jurisdiction.
9. **HIGH ALTITUDE INSTALLATIONS** — Air openings must be increased at higher altitudes. Use instruments and set for 11.5 to 12.5% CO₂.
10. **START-UP NOISE** — Late ignition is the cause of start-up noises. If it occurs recheck for electrode settings, flame shape, air or water in the fuel lines.
11. **SHUT DOWN NOISE** — If the flame runs out of air before it runs out of fuel, an after burn with noise may occur. That may be the result of a faulty cut-off valve in the fuel pump, or it may be air trapped in the nozzle line. It may take several firing cycles for that air to be fully vented through the nozzle. Water in the fuel or poor flame shape can also cause shut down noises.

NOTICE: CHECK TEST PROCEDURE. A very good test for isolating fuel side problems is to disconnect the fuel system and with a 24" length of tubing, fire out of an auxiliary five gallon pail of clean, fresh, warm #2 oil from another source. If the burner runs successfully when drawing out of the auxiliary pail then the problem is isolated to the fuel or fuel lines being used on the jobsite.

B. OIL PRIMARY CONTROL (Oil Primary)

1. Burner (Oil Primary) will not come on.
 - a. No power to Oil Primary.
 - b. Oil Primary is in lockout or restricted mode. Press reset button for one (1) second to exit lockout. If control has recycled three times within the same call for heat, it will enter into restricted mode. To reset from restricted mode, refer to Section 8, Paragraph J, No. 2 for details.
 - c. CAD cell seeing light.
 - d. CAD assembly defective.
 - e. Control motor relay is stuck closed (see note below).

12 Troubleshooting *(continued)*

2. Burner (control) will light, then shut down after a short time, then restart after one (1) minute.
 - a. CAD cell is defective.
 - b. Air leaking into oil line causing flame out.
 - c. Defective nozzle causing flame to be erratic.
 - d. Excessive airflow or draft causing flame to leave burner head.
 - e. Excessive back pressure causing flame to be erratic.
3. Control locks out after Trial For Ignition (TFI).
 - a. No oil to burner.
 - b. Shorted electrodes.
 - c. Nozzle clogged.
 - d. Airflow too high.
 - e. Ignitor module defective.
 - f. CAD cell defective.
 - g. Oil valve stuck open or closed.

Note: The Safety Monitoring Circuit (SMC) is designed to provide lockout in the event of a stuck or welded motor relay.

NOTICE: If flame is not established within 15 seconds of oil valve actuation (known as Trial For Ignition [TFI]) lockout will occur. Lockout is indicated by a red LED solid-on located on the oil primary control.

Latch-up will occur if the control locks-out three (3) times during a call for heat. This is indicated by steady-on red and amber LED's.

12 Troubleshooting *(continued)*

Burner Will Not Fire	See Flow Chart 1
Burner Will Not Shut Down	See Flow Chart 2
Temperature Display Exceeds High Limit Setting	Under normal operation, boiler temperature will continue to rise after the control shuts off the burner. This condition, known as “thermal stacking,” results from hot boiler surfaces continuing to release heat into the boiler water.
No or Insufficient Domestic Hot Water	For boiler equipped with a tankless coil, make sure the low limit setting on the HydroState is set properly. NOTE: If the low limit setting is dialed fully clockwise, it will shut off the low temperature maintenance feature and will function as a cold start control. If installed with an indirect water heater, check that the Zone/Indirect Switch is set in the Indirect (I) position. Verify that the end switch in the relay box controlling the indirect water heater is connected to the ZC/ZR terminals. This will ensure that the domestic water calls are prioritized. (See “Heating and Indirect Water Heater.”)
Low Water Light (Red LED) is On or Blinking	<p>WARNING: A low water condition is a serious and potentially dangerous condition. Do not attempt to add water to a hot boiler. Allow the boiler to fully cool before adding water.</p> <p>When Installed on an Electro-Well™</p> <p>When the LOW WATER light is on, this indicates that the control is not detecting water in the boiler. When the LOW WATER light is blinking, this indicates that the control has been programmed to provide low water lock-out protections and is currently locked out (see Manual Reset Low Water Cut-Off). Pressing the TEST/SETTINGS button after the low water condition is resolved will reset the lock-out condition.</p> <ol style="list-style-type: none"> 1. If the light is on and the heating system is filled with water, pull the sensor out of the well and inspect it. Make sure that the metal clip is protruding enough to come in contact with the inside of the well tube. Check that the well does not have excessive build-up of heat transfer grease that may interfere with the clip contacting the well. 2. Remove well and examine for excessive residue build-up. Clean and re-install. <p>When Installed on a Standard Immersion Well</p> <p>If either LWCO LED lights are illuminated and the control is installed on a standard immersion well, this is false reading caused by a loss of continuity between the sensor and the inside of the well tube. Follow steps 1 and 2 (above) to ensure that the metal sensor head is making good contact with the inside surface of the copper well.</p>
Boiler Will Not Maintain Low Limit Temperature	Check for overlapping high temperature setting. If the high limit setting is set below the low limit setting, the control will default to the high limit setting and the corresponding high limit differential setting.
House Will Not Get or Stay Warm	<ol style="list-style-type: none"> 1. Check for air-bound radiators 2. Check thermostat settings including heat anticipator settings (common on non-digital thermostats). 3. Check the Economy setting. The Economy feature, much like outdoor reset controls, from average boiler temperature and can slow or, in some cases, prevent the house from coming up to temperature. Move to a lower setting (see “Setting the Economy Feature”).
Circulator Contacts C1 and C2 Not Energized on Call for Heat	Check to see that boiler water is at or above 125°F. On a call for heat, the control will not permit the circulator to operate if the boiler water temperature is below 125°F (see “Circulator Hold Off”).
All LED Lights and Temp Display are Blinking	If the LED lights and the temp display are blinking alternately, this indicates the control has sensed a boiler temperature of 250°F. When this occurs, the control pulses the burner relay and then shuts down and lock-out the burner. The system should be analyzed to determine the cause of the overheating condition. Check that the sensor is inserted all the way into the well so it can accurately sense the temperature of the boiler water. Check the load on the burner contacts: If the load exceeds the 7.4 Amp rating, the contacts may have welded. Correct the overloading condition and replace the control before reenergizing the system. If the load on the contacts is below the rating, check system wiring and operation as well as the control's high limit setting. If the cause of the overheating is found and the system is deemed safe, the control can be reset by removing power from the control and then repowering while simultaneously pressing the Test/Settings button on the top of the control. If the cause of the overheating condition is not determined, the control should be replaced.

12 Troubleshooting *(continued)*

Troubleshooting Flow Chart 1 - Burner Will Not Fire

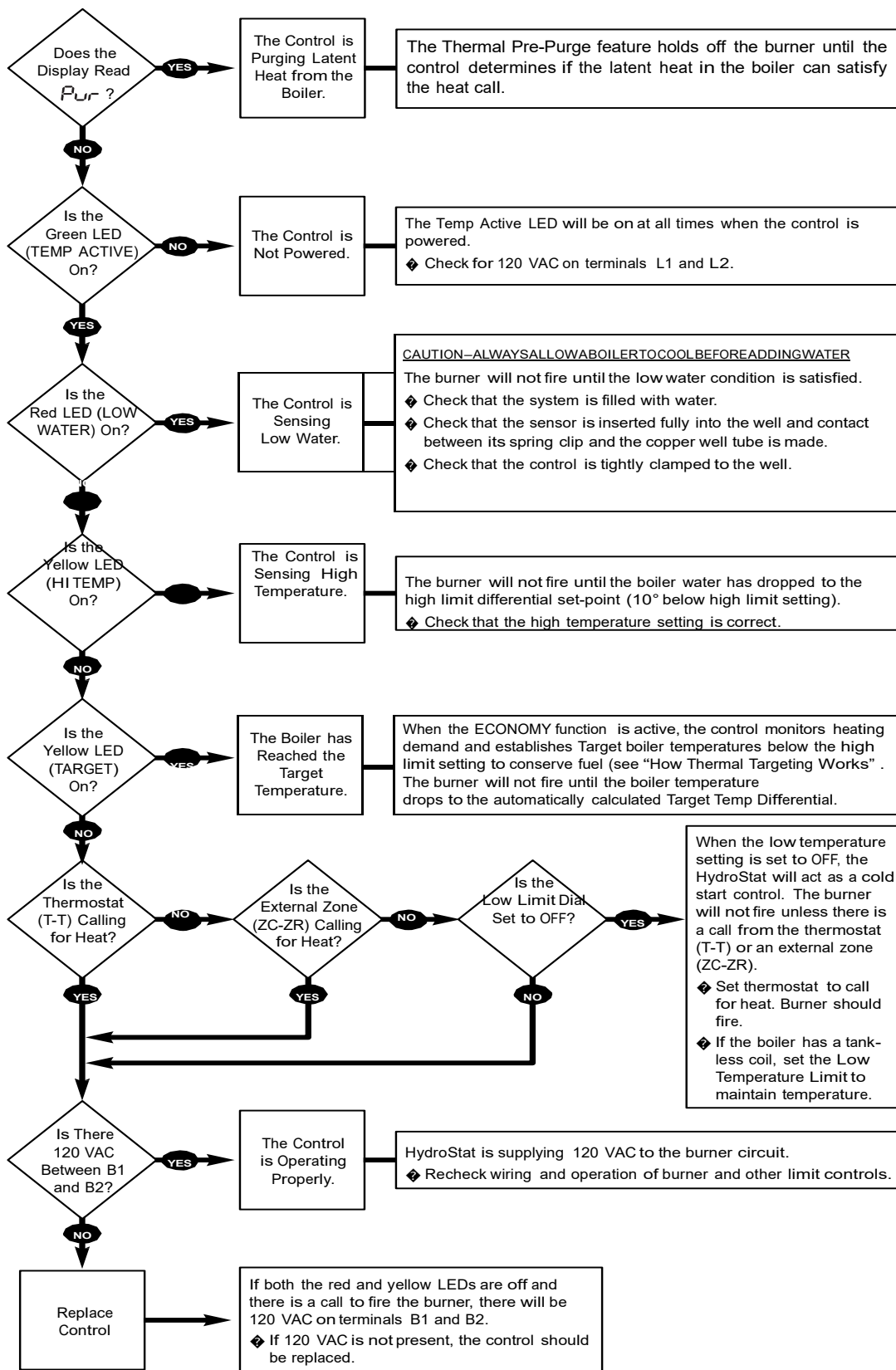

12 Troubleshooting *(continued)*

Troubleshooting Flow Chart 1 - Burner Will Not Shut Down

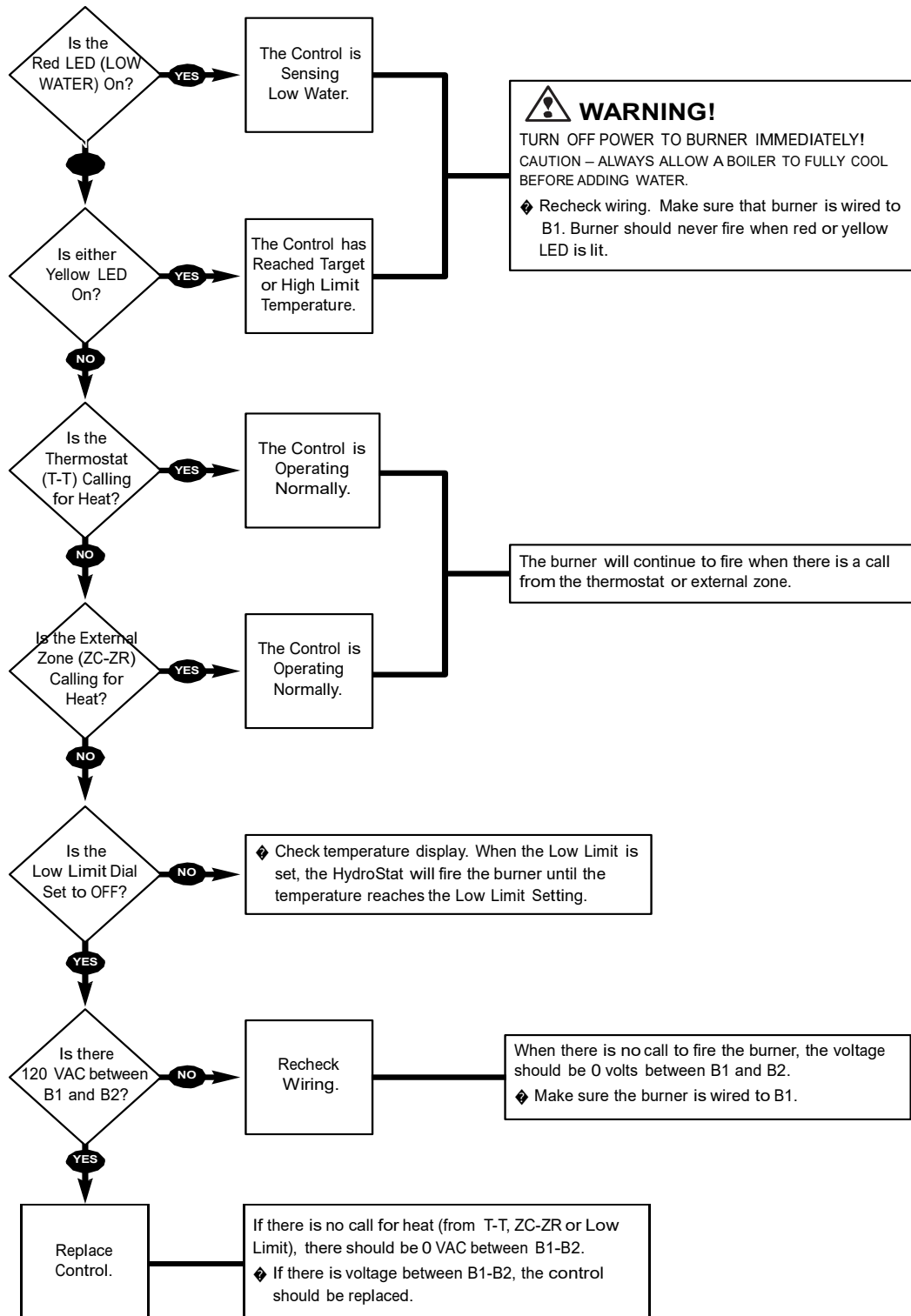

13 Service Parts

All EMP Boiler Service Parts may be obtained through your local U.S. Boiler Company Wholesale distributor. Should you require assistance in locating a U.S. Boiler Company Distributor in your area, or have questions regarding the availability of U.S. Boiler Company products or service parts, please contact U.S. Boiler Company Customer Service at (717) 481-8400 or Fax (717) 481-8408. 

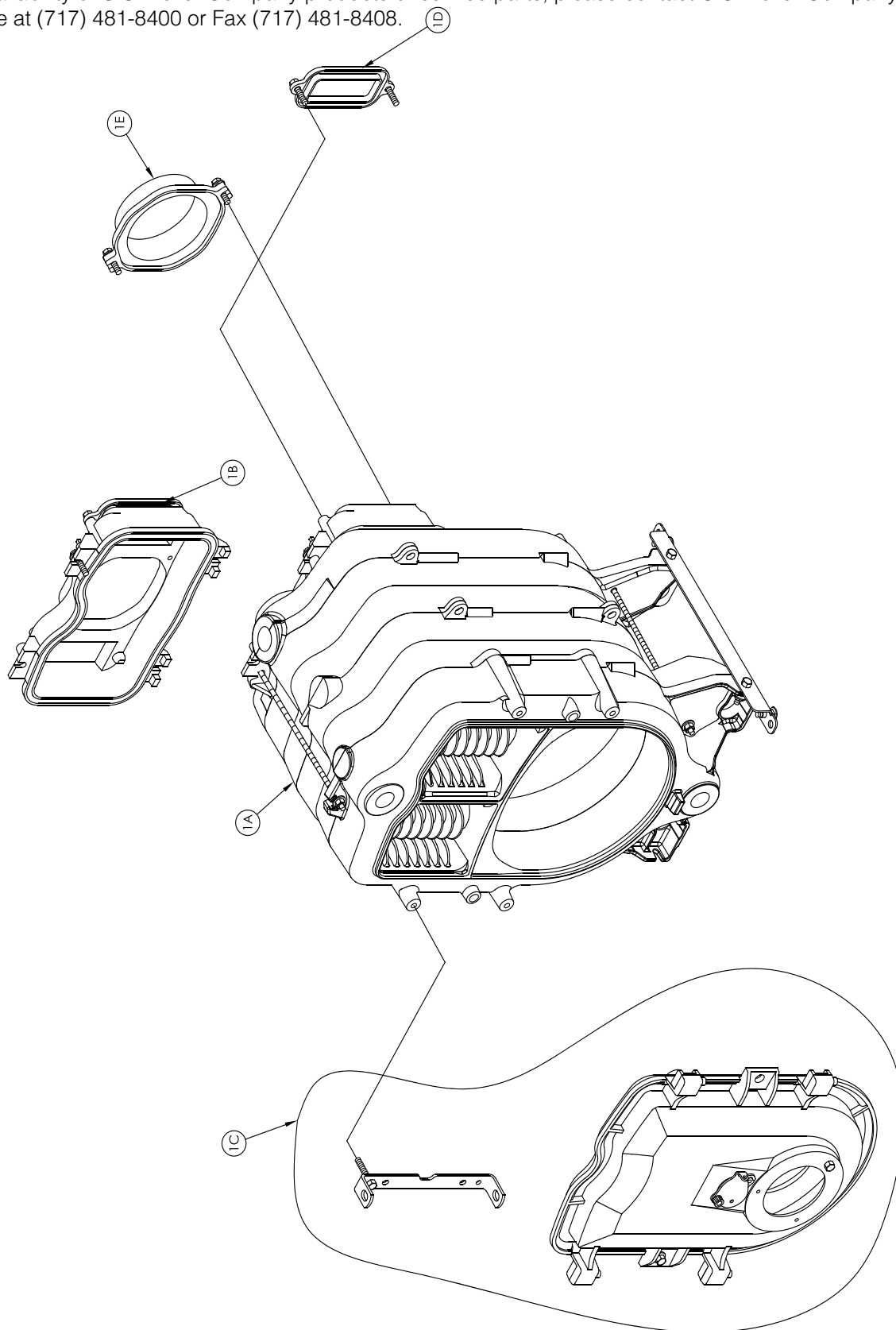

Bare Boiler Assembly

13 Service Parts *(continued)*

Item No.	Description	Part No.	EMP84E	EMP115E	EMP140E	EMP182E	EMP224E	EMP280E	EMP336E
1A	Heater Block Assembly Includes: Block	109554-02	1	1					
		109554-03			1				
		109554-04				1			
		109554-05					1	1	
		109554-06							1
1B	Smoke Box Includes: Sealant and Hardware	109555-01	1	1	1	1	1	1	1
1C	Burner Swing Door Assembly Includes: Hinge and Hardware	109556-01	1	1	1	1			1
		109557-01					1	1	
1D	Cleanout Cover Assembly Includes: Hardware	109563-01	2	2	2	2	2	2	2
1E	Flue Collar Includes: Hardware	109567-01	1	1					
		109568-01			1	1			
		109569-01					1	1	1
Not Shown	Gasket Assembly Includes: Door Rope Gasket, Door Insulation, two (2) Cleanout Cover Rope Gaskets, and RTV Sealant	109738-01	1	1	1	1			1
		109738-02					1	1	

13 Service Parts *(continued)*

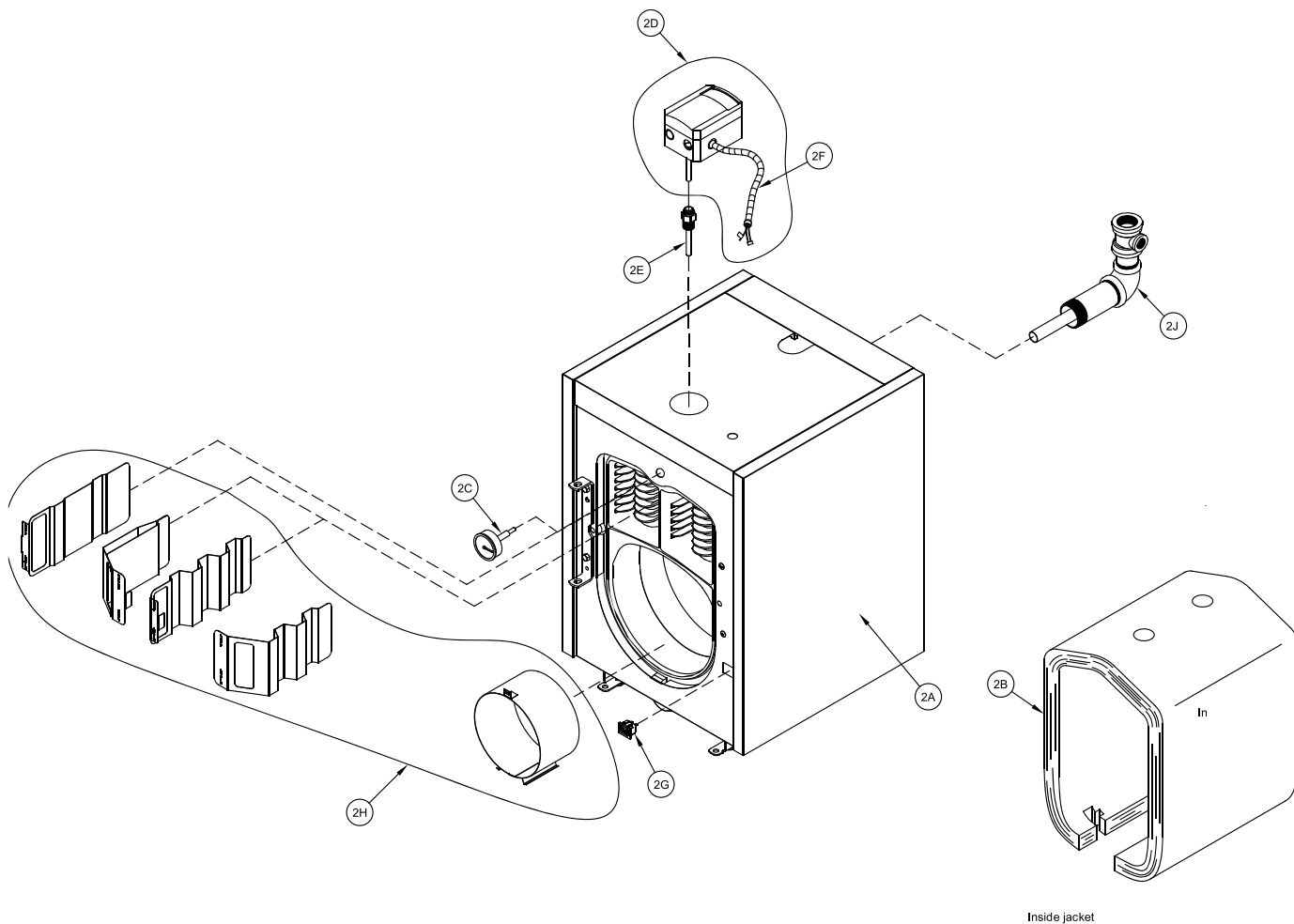

Jackets and Trim

13 Service Parts *(continued)*

Item No.	Description	Part No.	EMP84E	EMP115E	EMP140E	EMP182E	EMP224E	EMP280E	EMP336E	
2A	Complete Jacket Carton Includes: Labels and Hardware	109552-02	1	1						
		109552-03			1					
		109552-04				1				
		109552-05					1	1		
		109552-06							1	
2B	Wrap Around Insulation	109553-02	1	1						
		109553-03			1					
		109553-04				1				
		109553-05					1	1		
		109553-06							1	
2C	Control Assembly	109564-01	1	1						
	Harness	109565-01			1	1	1	1	1	
2D	Temperature & Pressure Gauge	105894-01	1							
2E	Electro-Well, 1/2 in. NPT x 3-1/4 in.	109566-01	1	1	1	1	1	1	1	
2F	Burner Receptacle	109570-01	1	1	1	1	1	1	1	
2G	Baffle Kit	109991-01	1							
		111779-01		1						
		109558-01			1	1	1			
		112560-01						1		
		112561-01							1	
2H	Injector Kit	102827-01	1	1	1	1	1			
		112560-01						1		
		112735-01							1	
Not Shown	Relief Valve, Conbraco, 3/4 in. FIP x 3/4 in. FIP	#10-408-05 30 PSI	Obtain Locally	1	1	1	1	1	1	
		#10-303-07 40 PSI								
		#10-303-10 50 PSI								
	5 in. Draft Regulator	1		1						
	6 in. Draft Regulator				1	1				
	7 in. Draft Regulator						1	1	1	
	Drain Valve, 3/4 in. NPT	1		1	1	1	1	1	1	
	Circulator Flange, 1 1/2 in. NPT	2		2	2	2	2	2	2	
	Circulator Gasket	Taco #194-1548 Grundfos		2	2	2	2	2	2	2
	Circulator	Taco 007e Grundfos UPS 15-55FC		1	1	1	1	1	1	1

13 Service Parts *(continued)*

Item No.	Description		Part Number	EMP84E	EMP115E	EMP140E	EMP182E	EMP224E	EMP280E	EMP336E	
Not Shown	Beckett	Natural Draft	112202-01	1							
			112203-01		1						
			112204-01			1					
			112205-01				1				
			112206-01					1			
			112555-01						1		
		112556-01							1		
		Direct Vent	112207-01			1					
			112208-01				1				
	112209-01						1				
	Carlin	Natural Draft	110109-02	1							
			110110-02		1						
			110111-03			1					
			110112-04				1				
			110113-05					1			
	Primary Control	Beckett	GeniSys 7565	Obtain Locally	1	1	1	1	1	1	1
		Carlin	Pro-X 70200		1	1	1	1	1	1	1
Burner Disconnect Harness			102115-01	1	1	1	1	1	1	1	

13 Service Parts *(continued)*

Item No.	Description	Part No.	EMP140E	EMP182E	EMP224E
Direct Vent Kits and Parts					
	Direct Vent Conversion Kit, 5-6	102130-02	1	1	---
	Direct Vent Conversion Kit, 6-7	102130-03	---	---	1
5B	Appliance Adapter, FDVS, 5-6	100234-02	1	1	---
	Appliance Adapter, FDVS, 6-7	100234-03	---	---	1
5C	6 in. Appliance Clamp, FDVS-6, Half	100235-02	2	2	---
	7 in. Appliance Clamp, FDVS-7, Half	100235-03	---	---	2
5D	Cover Sleeve Assembly, FDVS-5	100236-02	2	2	---
	Cover Sleeve Assembly, FDVS-6	100236-03	---	---	2
5E	Cover Ring Assembly, FDVS-5	100237-02	2	2	---
	Cover Ring Assembly, FDVS-6	100237-03	---	---	2
5F	Inner Pipe Clamp, FDVS-5, Half	100238-02	4	4	---
	Inner Pipe Clamp, FDVS-6, Half	100238-03	---	---	4
6. Flex Oil Vent Pipe					
6A	5 in. Dia. x 10 ft. FOVP-510	100212-02	1	1	---
	5 in. Dia. x 20 ft. FOVP-520	100214-02			
	6 in. Dia. x 10 ft. FOVP-610	100212-03	---	---	1
	6 in. Dia. x 20 ft. FOVP-620	100214-03			

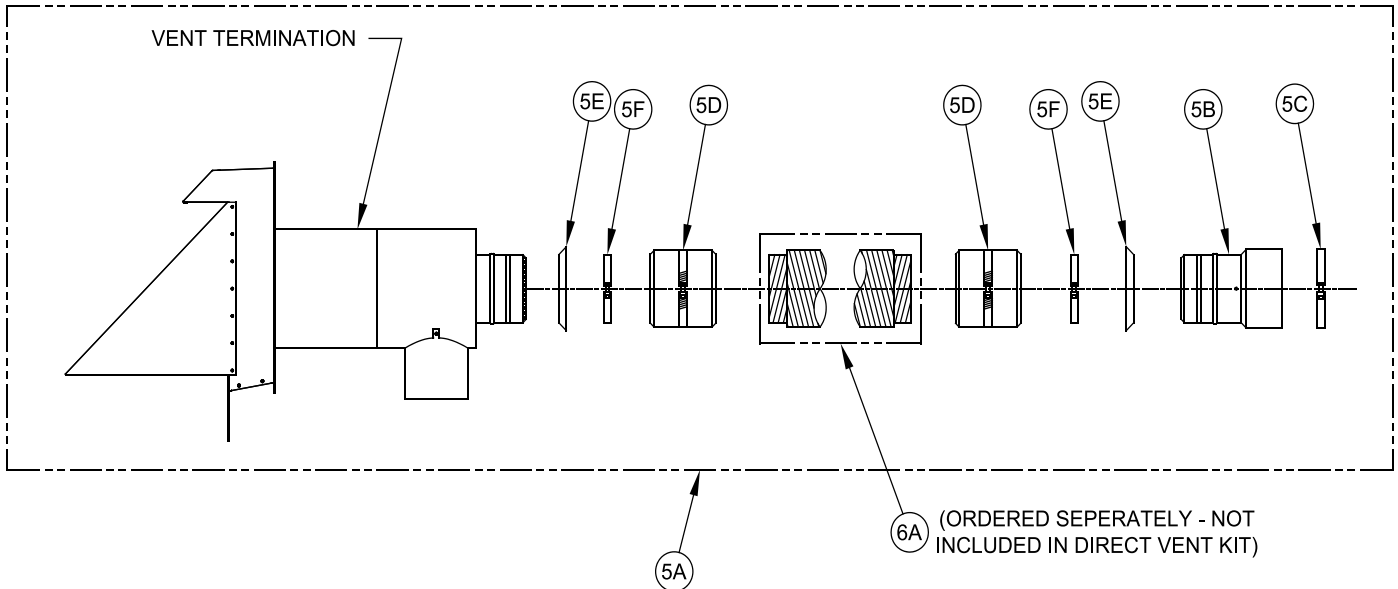

13 Service Parts *(continued)*

CARLIN OIL BURNER PART NUMBERS FOR EMP SERIES BOILERS

NOTE: When ordering parts always give the serial and model numbers shown on the boiler and burner.

Refer to *Installation and Operating Instructions for Packaged Heating/Burner Units, Carlin Elite EZ-LF and EZ-66 Oil Burners* (Form CCT-569A) for an exploded view of the burner and a list of spare parts.

For replacement Carlin oil burner parts, contact your wholesaler or the burner manufacturer:

CCT, Carlin Combustion Technology, Inc.
26 Bailey Road
North Haven, CT 06473
Telephone: (203) 776-0473
Facsimile: (203) 764-1711

14 Burner Specifications

Table 14-1: Beckett AFG Burner Specifications - Chimney Vent

Boiler Model	Burner Input (GPH)	Burner Model	Nozzle	Air Shutter (setting)	Air Band (setting)	Pump Pressure (PSI)	Head Type (setting)	Insertion Depth (Inch)	Approx. Shipped CO ₂ (%)
EMP84E	0.60	AFG	0.50 x 45W Delavan	8 ⁽¹⁾	0	180	L2	2	11.5
EMP115E	0.80	AFG	0.60 x 45W Delavan	5	0	180	L2	2	11.5
EMP140E	1.00	AFG	0.75 x 60B Delavan	9	0	180	L1	2	11.5
EMP182E	1.30	AFG	1.00 X 60B Delavan	7	1	180	V1 (0)	2	11.5
EMP224E	1.60	AFG	1.25 x 60B Hago	10	3	180	V1 (3)	2	11.5
EMP280E	2.00	CF375	1.50 x 60B Delavan	10	1	180	V1 (4)	2	11.5
EMP336E	2.40	CF375	2.00 x 45B Delavan	10	5	170	V1 (6)	2	11.5

Notes

¹ EMP84 at 0.60 GPH firing rate utilizes a low fire baffle.

⁴ Single stage fuel pump is standard, two-stage fuel pump is optional. Burner manufacturer has preset single stage fuel pump to settings shown in table above. Two-stage fuel pump is factory set at 140 PSI and must be readjusted to settings shown above during burner start-up.

14 Burner Specifications *(continued)*

Table 14-2: Carlin EZ Burner Specifications - Chimney Vent

Boiler Model	Burner Input (GPH)	Burner Model	Nozzle	Head Setting	Air Setting	Pump Pressure (PSI)	Air Tube Type	Insertion Depth (Inch)	Approx. Shipped CO ₂ (%)
EMP84E	0.60	EZ-LF	0.50 x 60AS Danfoss	1.0	30	150	12D	2-5/8	11.5
EMP115E	0.80	EZ-LF	0.65 x 60A Delavan	0.75	65	150	12D	2-5/8	11.5
EMP140E	1.00	EZ-66	0.85 x 45AS Danfoss	2.0	40	150	Conical Wrap	2-5/8	11.5
EMP182E	1.30	EZ-66	1.10 x 45B Delavan	3.5	50	150	Conical Wrap	2-5/8	11.5
EMP224E	1.60	EZ-66	1.35 x 45B Delavan	5.5	60	150	Conical Wrap	2-5/8	11.5

Notes

⁴ Single stage fuel pump is standard, two-stage fuel pump is optional. Burner manufacturer has preset single stage fuel pump to settings shown in table above.

Two-stage fuel pump is factory set at 140 PSI and must be readjusted to settings shown above during burner start-up.

Table 14-3: Beckett NX Burner Specifications - Direct Vent

Boiler Model	Burner Input (GPH)	Head /Air Adjustment (setting)	Nozzle	Pump Pressure (PSI)	Approx. Shipped CO ₂ (%)
EMP140E	1.00	2.75	0.75 - 60°W Delavan	180	11.5
EMP182E	1.30	1.00	1.00 - 45°B Hago	180	11.5
EMP224E	1.60	2.25	1.25 - 45°B Hago	180	11.5

Notes

⁽⁴⁾ Single stage fuel pump is standard, two-stage fuel pump is optional. Burner manufacturer has preset single stage fuel pump to settings shown in table above. Two-stage fuel pump is factory set at 140 PSI and must be readjusted to settings shown above during burner start-up.

U.S. Boiler Company, LLC
P.O. Box 3020
Lancaster, PA 17604
1-888-432-8887
www.usboiler.net