

Installation, Operating and Service Instructions for

ALLIANCE SL™

Hydrastone-lined Indirect Water Heater

Models:

- AL27SL
- AL35SL
- AL50SL
- AL70SL
- AL70CSL

Residential & Commercial



Manual Contents	Page
1. General Information	2
2. Specifications & Ratings	3
3. Installation Guidelines	5
4. Installation Checklist.	8
5. Service Information.	9
6. TPI Control Diagrams	11
7. Installation Piping Figures	13
8. Top Mount Coil Details & Tightening Sequence . . .	15
9. Circulator & Burner Control Wiring Diagrams . . .	16
10. Zone Valve Wiring Diagrams.	17
11. Switching Relay Wiring Diagrams	18
12. Service Parts	20
13. How to Obtain Service Assistance.	21
Warranty.	22

To fully understand the purchaser's responsibilities for installing the water heater, please read the warranty.

TO THE INSTALLER:

Affix these instructions adjacent to indirect water heater.

TO THE CONSUMER:

Retain these instructions for future reference.



For service or repairs to the water heater, call your heating contractor. When seeking information on the water heater, provide Model Number and Serial Number as shown on Rating Label.



1 General Information

PLEASE READ INSTRUCTIONS CAREFULLY BEFORE INSTALLING WATER HEATER

U.S Boiler Company, LLC – (herein called the Company) intends that this Alliance SL™ Indirect-Fired Water Heater be used as a separate zone to a heating system boiler.

The company specifically does not warrant this tank for high temperature applications such as wood stoves or applications that supply steam to the Alliance SL heat exchanger coil. Such use of this product will automatically void the warranty. The Alliance SL can be used with any steam boiler as long as hot water is supplied to the indirect water heater as prescribed in this manual.

The design anticipates the proper installation and care in use of the product. There is risk of property damage and personal injury inherent in the use of any hot water system. The Company cannot supervise the installation and therefore makes it a specific condition of the warranty that the customer will supervise the installation and use of this product to be sure they are performed in accordance with safe guidelines and proper local or national codes.

Generalized instructions and procedures cannot anticipate all situations. For this reason, only qualified installers should perform the installation. A qualified installer is a person who has licensed training and a working knowledge of the applicable codes, regulations, tools, equipment and methods necessary for safe installation of a boiler system and an indirect water heater.

An installation checklist has been provided to help the customer ensure that all procedures for a safe installation have been followed.

If questions regarding installation arise, check with your local plumbing and electrical inspectors for proper procedures and codes. Local codes take a precedent over instructions in this manual.

2 Specifications & Ratings

The Massachusetts Board of Plumbers and Gas Fitters has approved the Alliance SL™ Indirect-Fired Water Heater. See the Massachusetts Board of Plumbers and Gas Fitters website, http://license.reg.state.ma.us/pubLic/pl_products/pb_pre_form.asp for the latest Approval Code or ask your local Sales Representative.

The Commonwealth of Massachusetts requires this product to be installed by a Licensed Plumber or Gas Fitter.



Rating Label Specifications

Model	Storage (gallons)	First Hour Ratings (gal/hr.)	Continuous Draw (gal/hr.)	Standby Loss (°F/hr.)	Heat Source Friction Loss (ft. w.c.)	Minimum Heat Source Output (Btu/hr.)	Minimum Heat Source Flow Rate (gpm)
AL27SL	26	192	170	1.0	18.0	106000	8
AL35SL	35	200	170	0.7	18.0	106000	8
AL50SL	50	225	180	0.6	19.0	117000	8
AL70SL	69	294	230	0.5	25.1	128000	8
AL70CSL	69	365	305	0.6	20.0	178000	14

Note:

1. First Hour Rating is the sum of the First Draw and Continuous Draw Ratings.
2. Ratings based on 77°F DHW temperature rise (135°F outlet temperature) and 180°F boiler supply temperature. The ratings were obtained at the heat source (boiler) output rates and heat source flow rates shown. Other results will be obtained under different conditions.

Additional Performance Specifications

Model	Performance Specifications					
	First Hour (Gal/hr.)		Boiler Output (6 GPM @ 200°F)	Boiler Water Continuous Flow		Standby Heat Loss
	115°F	140°F	(BTU/hr.)	Flow Rate (Gal/min.)	Head Loss (ft. w.c.)	(°F/hr.)
AL27SL	295	225	150,000	6	7	0.78
AL35SL	300	230	150,000	6	7	0.72
AL50SL	320	250	150,000	6	7	0.56
AL70SL	340	270	150,000	6	7	0.45
AL70CSL	475	385	235,000	14	14	0.45

Based on:

- 50°F inlet water temperature
- 200°F boiler supply to coil
- Outputs may vary depending on boiler size, boiler water supply temperature, flow rate through coil, and circumstances of installation and use.

2 Specifications & Ratings *(continued)*

Model	Physical Specifications			Connections (NPT)				
	Height (in.)	Diameter (in.)	Shipping Weight (lbs.)	Cold Water Inlet	Hot Water Outlet	To Boiler	From Boiler	T&P Valve
AL27SL	39-1/4	20	172	3/4 M	3/4 F	3/4 M	3/4 M	3/4 F
AL35SL	39-1/4	22-3/4	185	3/4 M	3/4 F	3/4 M	3/4 M	3/4 F
AL50SL	40-3/4	26	238	3/4 M	3/4 F	3/4 M	3/4 M	3/4 F
AL70SL	45-3/4	28	290	3/4 M	3/4 F	3/4 M	3/4 M	3/4 F
AL70CSL	45-3/4	28	290	1-1/2 M	1-1/2 M	1 M	1 M	3/4 F

3 Installation Guidelines

A. INSPECTING AND PREPARING THE WATER HEATER

- Remove the cardboard box, which comes packaged with the heater.
It should contain the following: TPI thermostat, T&P valve and a "Tee", foamed lid and screws.

B. LOCATION

- Do not place the water heater where there is a risk of property damage in the event of a leak.
- Place the water heater on a solid foundation in a clean, dry location nearest the boiler.
- The water heater should be protected from freezing and water lines should be insulated to reduce energy and water waste.
- Leave sufficient headroom to service the heat exchanger and electrical controls.
- Do not install in an area where flammable liquids or combustible vapors are present.
- CAUTION: The water heater's outer jacket is plastic and can melt.**
- Do not install in close proximity to wood burning stove or other high temperature apparatus.

NOTE: If Water Heater is Placed On Blocks To Raise It From The Floor,
Be **Sure** to Support The **Entire** Bottom With At Least $\frac{3}{4}$ in. Plywood On The Top Of The Blocks.

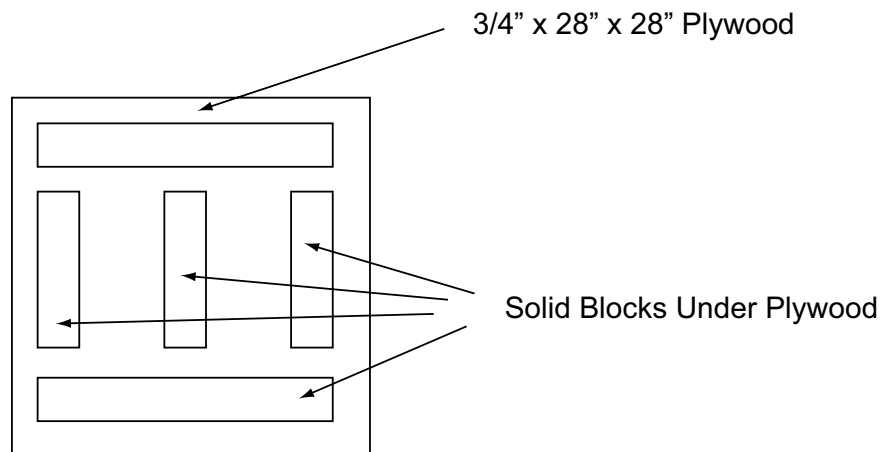

C. PROTECTION FROM WATER DAMAGE

- CAUTION: All water heaters have a risk of leakage at some unpredictable time.**
- IT IS THE CUSTOMER'S RESPONSIBILITY TO PROVIDE A CATCH PAN OR OTHER ADEQUATE MEANS, SO THAT THE RESULTANT FLOW OF WATER WILL NOT DAMAGE FURNISHINGS OR PROPERTY. (See Figure 1).**

D. RELIEF VALVE

- WARNING: A POTENTIAL HAZARD TO LIFE AND PROPERTY MAY EXIST IN ANY WATER HEATER IF AN APPROVED TEMPERATURE-AND-PRESSURE RELIEF VALVE IS NOT PROPERLY INSTALLED.**
- For protection against excessive pressures and temperatures in this water heater, install temperature-and-pressure protective equipment by local codes, but not less than a combination temperature-and-pressure relief valve certified by a nationally recognized testing laboratory that maintains periodic inspection of production of listed equipment of materials, as meeting the requirements for Relief Valves and Automatic Gas Shutoff for Hot Water Supply Systems, ANSI Z21.22-1971. This valve must be marked with maximum set pressure not to exceed the marked maximum allowable working pressure of the water heater (150psi). Install the valve into the opening provided and marked for this purpose in the water heater, and orient it or provide the

3 Installation Guidelines *(continued)*

tubing so that any discharge from the valve will exit only within 6 inches above, or at any distance below the structural floor and cannot contact any live electrical parts. The discharge opening must not be blocked or reduced in size under any circumstances.

- **CAUTION:** A relief valve is designed to discharge excessively hot water. **THE CUSTOMER IS RESPONSIBLE TO PROTECT PROPERTY AND PERSONNEL FROM HARM WHEN THE VALVE FUNCTIONS.**
- Install the T&P provided on hot water outlet of tank as shown in Figures 1, 2 and 3.
- Care must be taken to be sure that the stem of the pressure-and-temperature relief valve is immersed in the water within the top 6 inches of the tank.
- The drain line from the relief valve must not be concealed or blocked and must be protected from freezing.
- **WARNING: IF THE WATER SUPPLY IS FROM A WELL, OR KNOWN TO HAVE HARD WATER, IT IS RECOMMENDED TO USE A PRESSURE RELIEF VALVE IN THE COLD WATER LINE AS WELL AS A T&P VALVE IN THE HOT WATER LINE.**

E. WATER SUPPLY CONNECTIONS

- **WARNING: Some local codes mandate the use of a backflow preventer or check valve or pressure-reducing valve. An adequate expansion tank (or other adequate means) must be installed to prevent pressure build up or damage from thermal expansion when a check valve or backflow preventer or pressure-reducing valve is used. Failure to do so could result in tank leakage and therefore void the warranty. (See Figures 1, 2 and 3 for proper location)**
- All water supply fittings on this heater are brass – do not over tighten or strip threads.
- It is recommended to use a union as per Figures 1, 2, and 3.
- Do not apply heat directly to the cold-water inlet as it is made of plastic and will melt.

F. BOILER SUPPLY CONNECTIONS

- **WARNING: Boiler temperature must be controlled by the boiler high limit not to exceed 200°. Failure to do so will create a hazardous installation and void the applicable limited warranties.**
- All water supply fittings on this heater are brass – do not over tighten or strip threads.
- It is recommended to use a union as per Figures 1, 2 and 3.

NOTE: Be sure to connect Boiler Supply Line (from the boiler) to the “HX in” fitting and Boiler Return Line (to the boiler) to the “HX Out” fitting.

G. FILLING THE HEATER

- Check that the temperature-and-pressure relief valve has been properly installed (mandatory requirement).
- Completely close the drain valve.
- Open the highest hot water faucet to allow air to escape from piping.
- Open the valve to the cold-water inlet and allow the heater and piping system to completely fill, as indicated by a steady flow of water from the open faucet.

H. FLUSHING THE HEATER

- When a new water heater is first put into service, the user may observe a temporary increase in the heated water's pH level. This is due to the “wet curing” process that the heater's cement lining normally undergoes. As the wet curing process continues, the pH level will diminish and eventually return to normal upon full curing. Under average usage, the wet curing process typically takes about 14 days to complete. In applications with relatively low water usage, the process will take longer.

3 Installation Guidelines *(continued)*

- Normally, the temporary increase in the heated water's pH level is not harmful, but it may be accompanied by one or more of the following symptoms:
 - Faint odor of wet cement
 - Silky or oily sensation on the skin
 - Residue left on dish ware after washing
 - Change in hair's texture after use of soap or shampoo
 - Minor skin irritations for those with sensitive skin
- In order to prevent more severe effects of elevated pH, the new water heater MUST be properly flushed prior to use. To flush the heater, the hot water faucet(s) should be opened and allowed to run until the water becomes cold. Once all of the hot water has been drawn from the heater, bring the water temperature inside the tank back up to its set point. Then, open one of the hot water faucets and draw a sample of hot water.
- Measure the pH level of the hot water using a pH kit (provided by others). If the pH level of the hot water is above 9, take a water sample from one of the cold water faucets and measure its pH. If the cold water's pH is above 9, the heater is not the source of the water's elevated pH level. Contact the local water authority if this is the case. If the cold water's pH is at or below 9, repeat the above flushing process until a pH of 9 (or below) is measured in a sample of heated water, and above symptoms subside. If the pH level is still above 9 after multiple flushings, contact US Boiler Company for further recommendations.

CAUTION: After a newly installed Alliance heater is initially filled, if water is not drawn from it for several days or weeks, the pH level of the water inside the heater may rise higher than what is normally expected, even if the heater had been flushed prior to this period of inactivity. To avoid adverse reactions to this elevated pH, the heater MUST be properly flushed and a sample of heated water MUST be measured to verify that its pH is 9 or below prior to use.

I. TPI THERMOSTAT INSTALLATION

- **Attaching TPI Thermostat to tank:**
Place hole in back of TPI thermostat over immersion well. TPI thermostat should fit flush against the tank without immersion well protruding beyond cover of TPI case. Use self-tapping screw provided **(Screw A)** to attach TPI directly to the Alliance SL tank. **(See TPI Diagram 2)**
 - **Inserting the Temperature Sensor:**
Slide temperature sensor all the way into the immersion well – until it contacts the end. **(See TPI Diagram 2)**
 - The sensor will measure temperature adequately by resting against the bottom of the immersion well.
- (Note: Sensor does NOT need to make intimate contact with entire well surface to work properly)**
- **CAUTION: Sensor is soldered directly to TPI. DO NOT BEND SHARPLY OR OVERWORK.**

J. TPI WIRING CONTROLS

NOTE: CONTROL ELECTRONICS MUST BE POWERED WITH 24VAC.

- Incoming 24 VAC power must be connected to 24VAC connectors on the bottom right corner of TPI Thermostat. **(See TPI Diagram 3)**
- The TPI 24 VAC only requires 20mA, or about 0.5 Watts.
- Connect control wiring to PUMP/TT normally open relay connections (rated for both 24V and 110V wiring) on the bottom left corner of TPI control. **(See TPI Diagram 3)**
- TPI Wiring will vary depending on the type of boiler and valve controls in the system. Consult attached Wiring Diagrams for appropriate wiring configuration for your system.
- The Alliance SL water heater may operate as a separate heating zone using either the heating system circulator and an appropriate zone valve, or a separate circulator dedicated for water heating. **(See Figure 1 & 2).**

3 Installation Guidelines *(continued)*

- In both systems, the Alliance SL is controlled through the TPI thermostat on the heater. **(See Figures 1 & 2).**
- *TPI thermostat calls for the heat when the temperature in the tank is below the set point (120°F) and either activates a circulator or zone valve depending upon installation design.*
- Run all 24 VAC wiring thru the square notch on bottom of TPI case. **(See TPI Diagram 3)**
- Incoming 24 VAC power must be connected to 24 VAC connectors on the bottom right corner of TPI control. **(See TPI Diagram 3)**
- Connect control wiring to PUMP/TT normally open relay connections (rated for both 24V and 110V wiring) on the bottom left corner of TPI control. **(See TPI Diagram 3)**
- All and only 110 VAC wiring must go through an appropriate chase nipple installed in the knockout at bottom of TPI case.
- Be certain to replace TPI cover using Black Screw provided.

4 Installation Checklist

A. INSPECTING AND PREPARING THE WATER HEATER

- Remove the cardboard box, which comes packaged with the heater. It should contain the following: TPI thermostat, T&P valve and a “Tee”, foamed lid and screws.

B. LOCATION

- Solid foundation and dry location.
- Protect heater water lines from freezing.
- Area free of flammable vapors.
- Sufficient room to service heater.
- Not in close proximity to wood burning stove.
- Where leak will not damage property.

C. PROTECTION FROM WATER DAMAGE

- **Be sure to make provisions to protect area from water damage if a leak should occur in the tank or connected fittings.**

D. RELIEF VALVE

- **Warning: Improper installation will present potential hazard to life and property.**
- Check to be sure that proper relief valve requirements are met.
- T&P installed as shown in Figures 1, 2 and 3.
- 3/4 in. discharge pipe – properly protected from freezing and restrictions.
- No valve between tank and relief valve or in drain line.
- Provision for hot water discharge from relief valve.

E. WATER SUPPLY CONNECTIONS **(See Figure 1, 2 & 3).**

- Do not over tighten brass threads.
- Mark the water shutoff for future reference.
- Do not apply heat to cold inlet.

4 Installation Checklist *(continued)*

- If there is a check valve (sometimes in water meter), backflow preventer or pressure-reducing valve, install an adequate size expansion tank.

F. FILLING THE HEATER

- Completely fill heater.
- Water connections completed and free of leaks.
- Check for proper installation of relief valve.
- Close drain valve.
- Open highest hot water faucet.
- Open cold water inlet valve and fill system.

G. FLUSHING THE HEATER

- Inform the home owner to flush the water heater if they experience a 'silky' feel accompanied by a mild odor to the water. See Flushing the Heater on Page 6 for details.

H. WIRING

See Figure 1 & 2 and separate TPI control wiring diagrams.

- TPI requires 24V to operate. See TPI installation for details.
- Wire either as a heating zone or separate circulator.
- Water heater temperature is controlled by TPI thermostat.
- **WARNING: Boiler must have high limit control set no more than 200°F.**

5 Service Information

WATER TEMPERATURE REGULATION

WARNING: Exposure to 125°F or hotter water can cause scalding injuries. Appropriate caution must be taken when using hot water. Special supervision must be given to those who cannot act quickly such as children, disabled or elderly persons.



The input of heat into the tank is controlled by an immersion thermostat. These automatic controls are set at the factory to maintain a water temperature of 120°F. Note: Although these thermostats are designed to industry standards, they can fail to control temperature properly without any notice, and therefore should be tested periodically for your protection.

DANGER: IF YOU DISCOVER EXTREME HOT WATER COMING FROM THE FAUCET, IMMEDIATELY SHUT OFF THE MAIN SWITCH TO THE BOILER AND CALL COMPETENT SERVICE PERSONNEL. ANY OVERHEATED WATER IS A POTENTIAL HAZARD TO LIFE AND PROPERTY. DO NOT OPERATE UNTIL THE SOURCE OF THE PROBLEM HAS BEEN DETERMINED AND ELIMINATED.

- Water temperature over 125°F can cause severe burns instantly or death from scalds.
- Children, disabled and elderly persons are at the highest risk of being scalded.
- See instruction manual before setting temperature at the water heater.
- Feel water before bathing or showering.

5 Service Information *(continued)*

Proper maintenance is important for any product. It is suggested that the purchaser follow the preventive maintenance program outlined below.

WATER TEMPERATURE CONTROLS

A periodic inspection of the operating controls, heat exchanger and wiring should be made by qualified service personnel. Temperature of the water should be tested periodically at the faucet to be sure thermostat is working properly.

TEMPERATURE ADJUSTMENT

The TPI comes with a factory set temperature setting of 120°F and differential setting of 10°F. Any temperature adjustment of the thermostat must be made by qualified service personnel, as shown below.

WARNING: See SERVICE INFORMATION Water Temperature Regulation, regarding safe water temperature before proceeding. Hot water can cause scalding injuries.

1. Shut off or disconnect all electrical supply to heater.
2. Remove cover to TPI control.
3. Adjust right side lever to the desired temperature. Moving lever down will decrease temperature. (See Figure at right and TPI Diagram 1).

NOTE: Markings on slide are approximate. Check temperature at faucet to ensure safe operating temperature.

4. Adjust left side lever to the desired differential. (See Figure at right and TPI Diagram 1) The TPI thermostat will call for heat when the tank temperature has fallen to the set differential degrees below the temperature set point.
5. Reattach cover.
6. Reconnect electrical supply.
7. Check faucet temperature to verify desired temperature is achieved.

In order to set the temperature above 140°F **{NOT RECOMMENDED}** you must remove the SCALD DANGER label attached to the temperature slide.

Caution: Do not increase temperature above 140°F without a properly installed mixing valve in the system – See Water Temperature Regulation and SCALD WARNING.

Indicator Light operation:

The TPI thermostat has an integral indicator light at the top of the case.

(See TPI Diagram 1 or Inside Cover of TPI)

Indicator light will come on (Green) when TPI is powered.

When TPI is calling for heat, the Indicator light will blink.

When TPI is satisfied, the Indicator light will be solid.

During normal operation, Indicator light is Green.

If TPI detects a failure, Indicator light will flash Red. Replace TPI.

EMERGENCY

Should the heater be subject to flood, fire or other damaging conditions, turn the power and water to the heater off. **DO NOT** place water heater in operation again until it has been thoroughly checked by qualified service personnel.

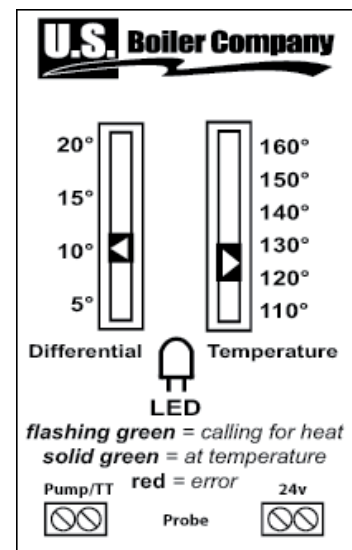

6 TPI Control Diagrams

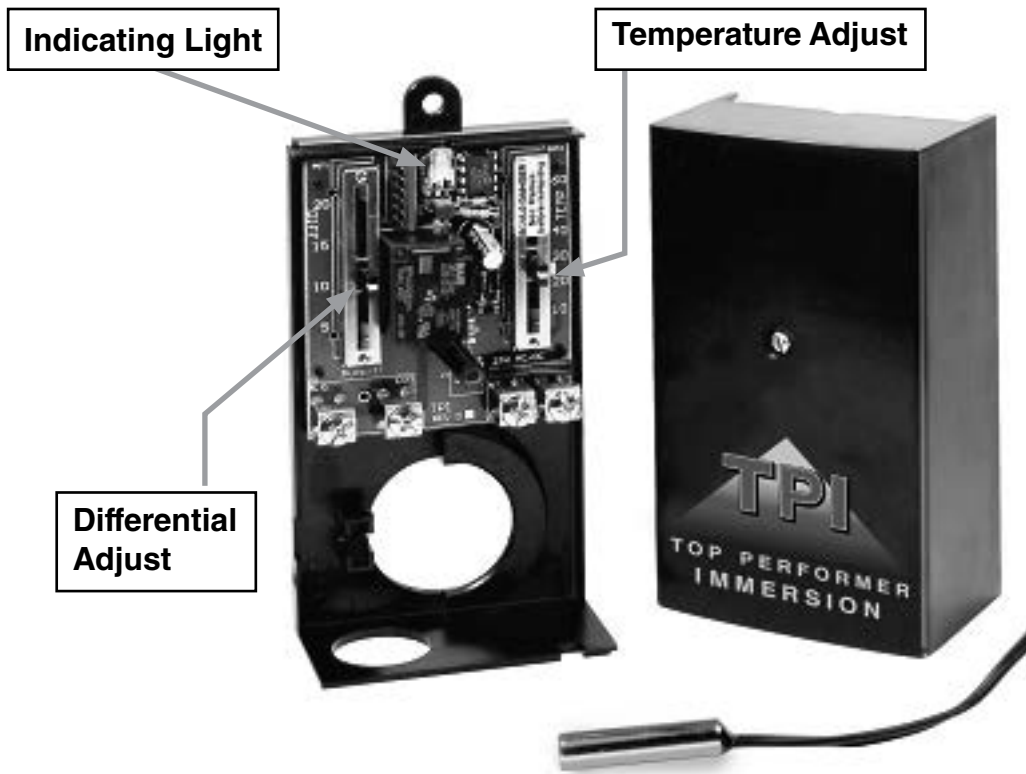

TPI CONTROL - DIAGRAM 1

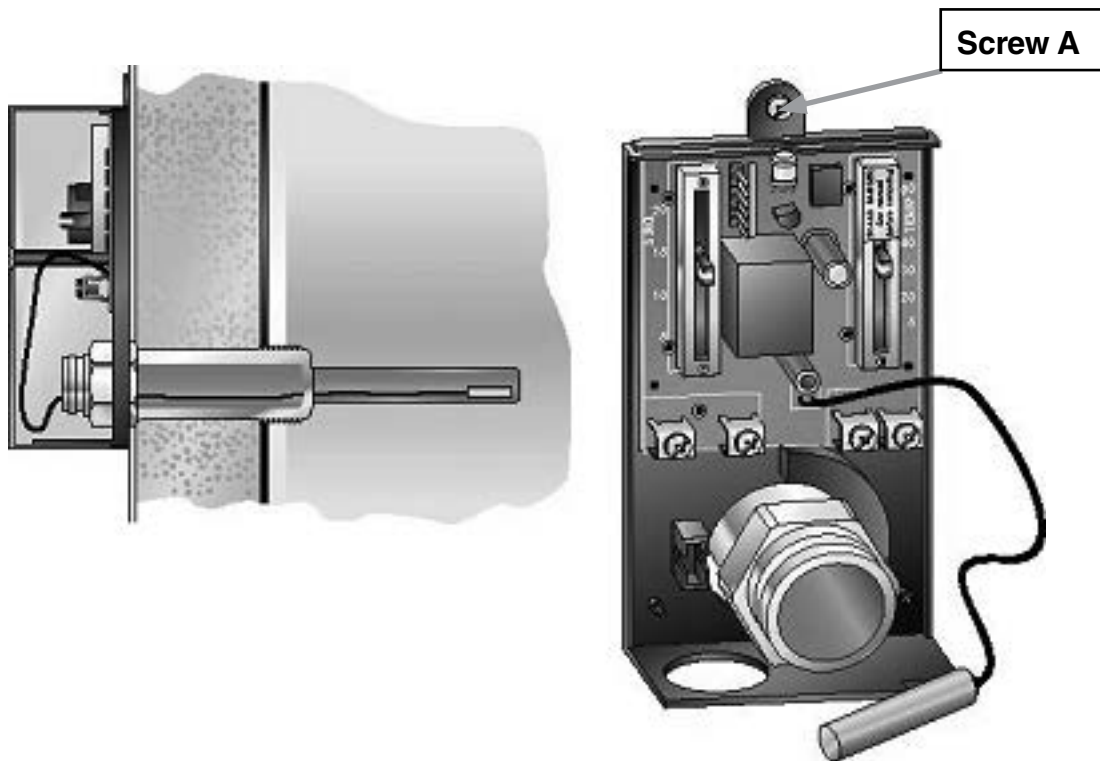

TPI CONTROL - DIAGRAM 2

6 TPI Control Diagrams *(continued)*

Outgoing 24V
wires to relay
or zone valve

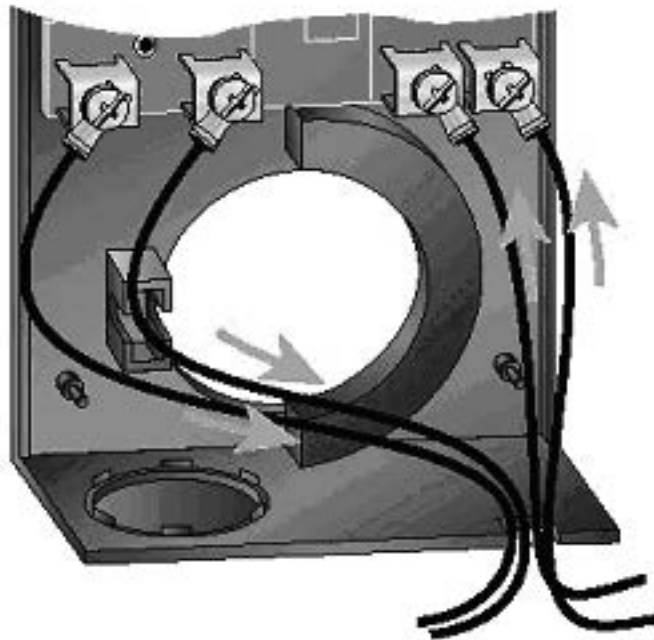

Incoming 24V
power
connection

Outgoing 110V
wires to
circulator

Chase Nipple

Conduit

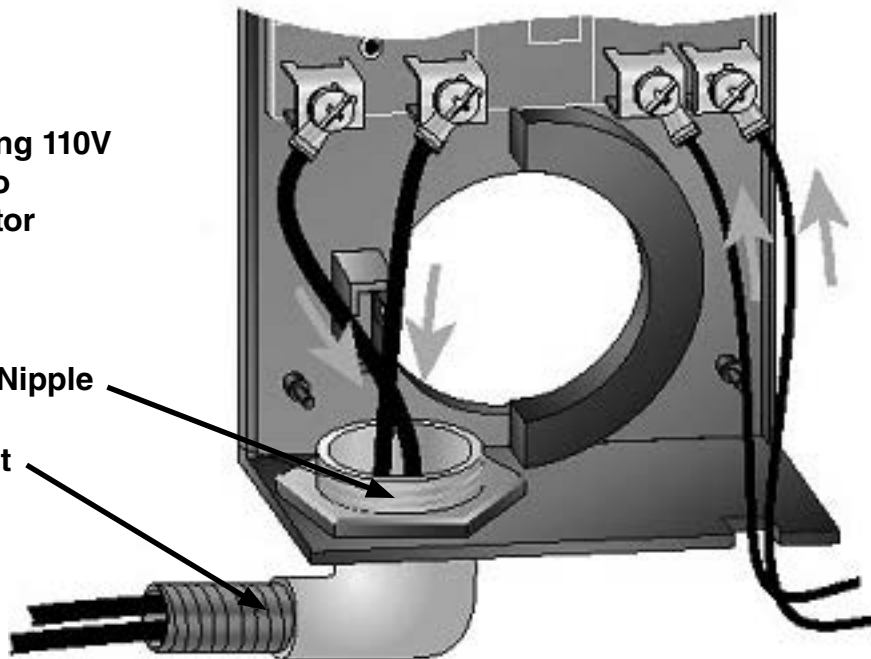

Incoming 24V
power
connections

NOTE: Use proper conduit
and chase nipple

TPI CONTROL - DIAGRAM 3

7 Installation Piping Figures

Installation Diagram Using Zone Valves

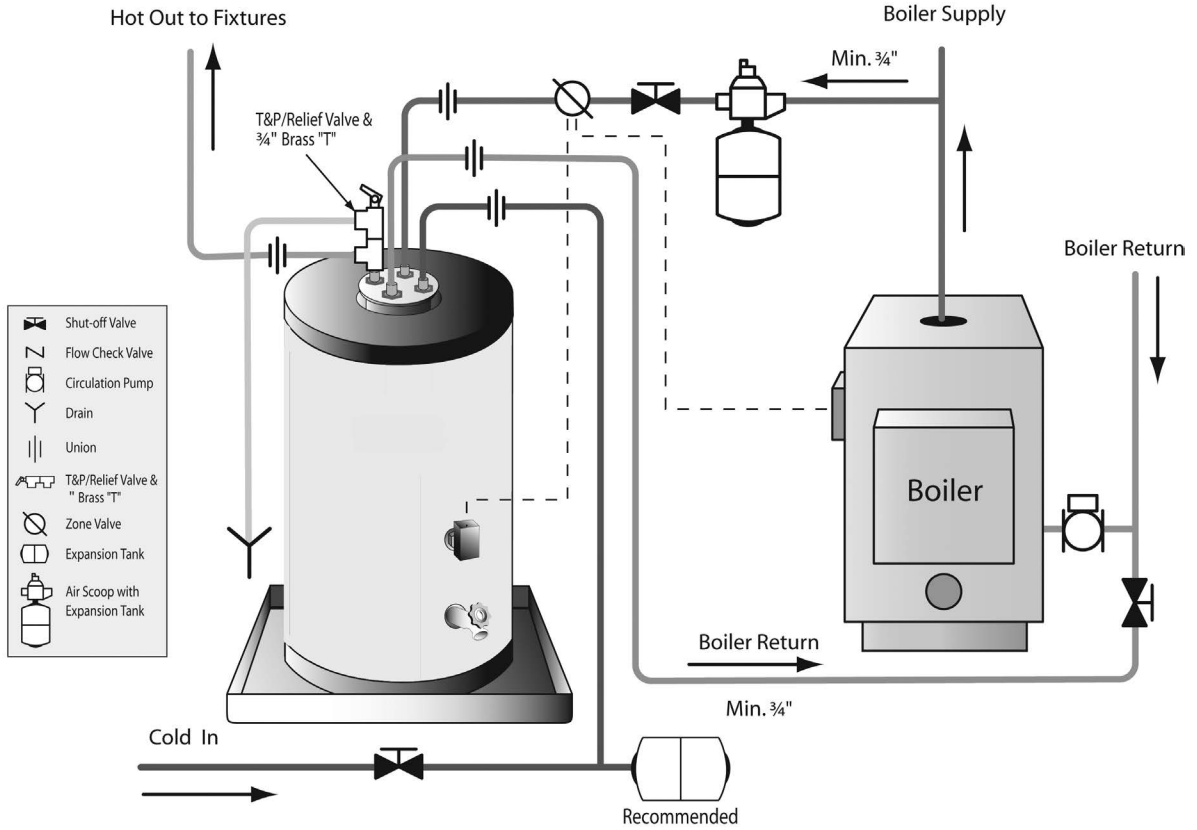

Figure 1: General Configuration

Installation Diagram Using Separate Circulator

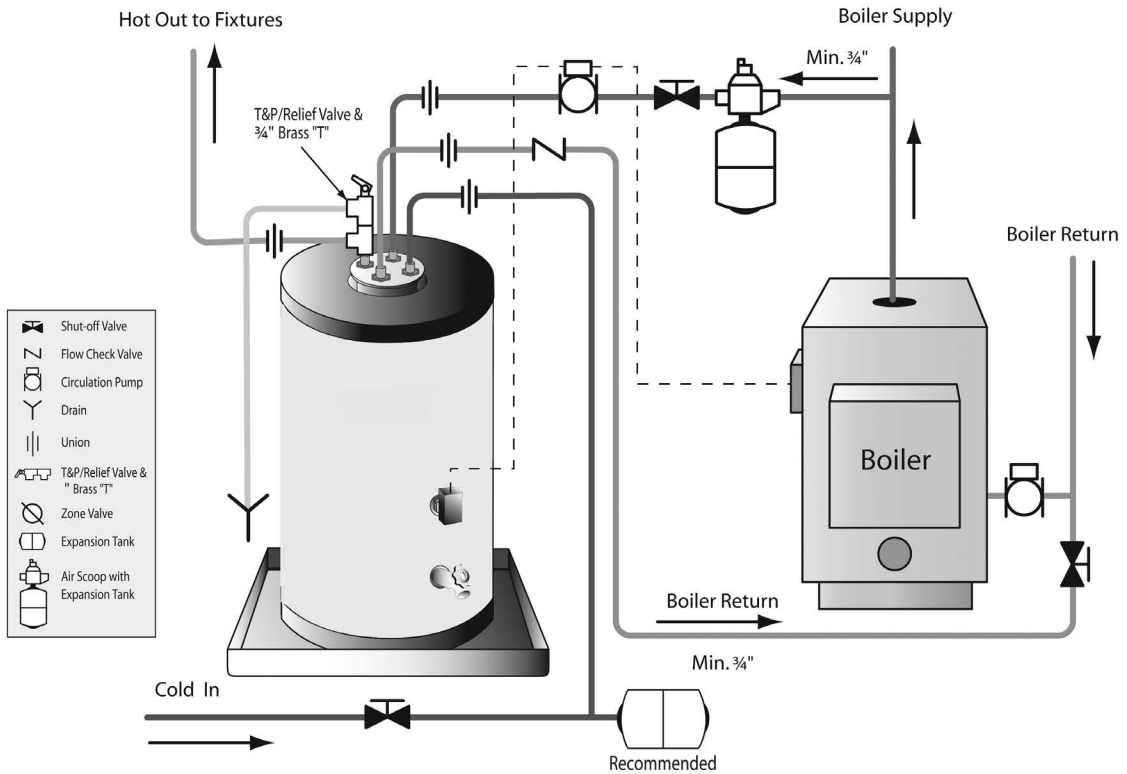

Figure 2: Installation Using Circulator

7 Installation Piping Figures *(continued)*

Installation Diagram Using a Single Tank

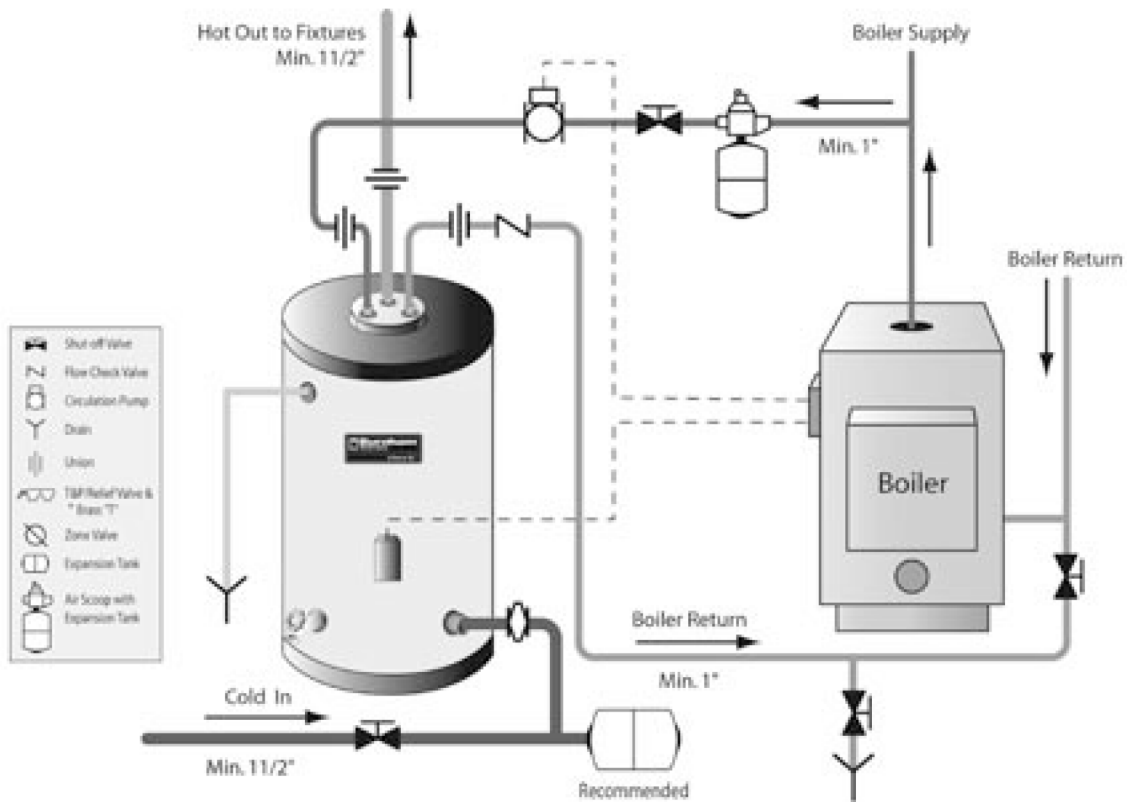

Figure 3: Commercial

8 Top Mount Coil Details & Tightening Sequence

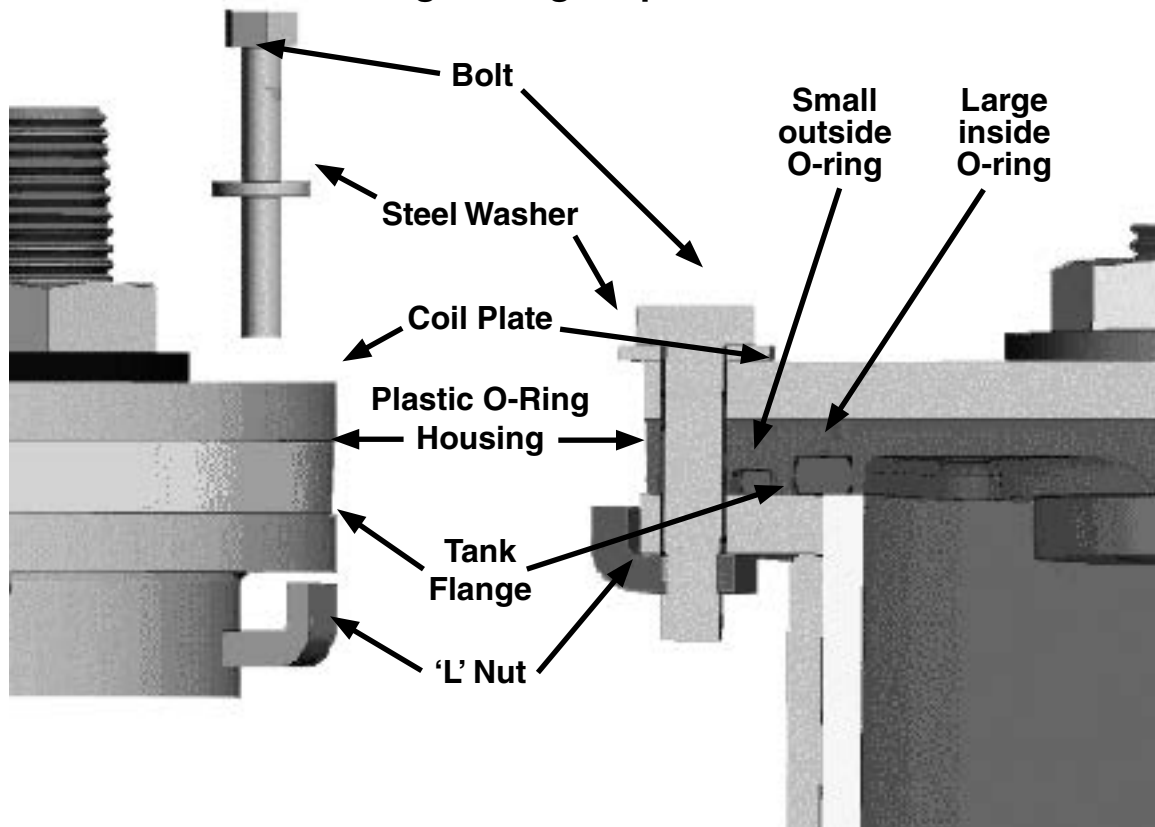
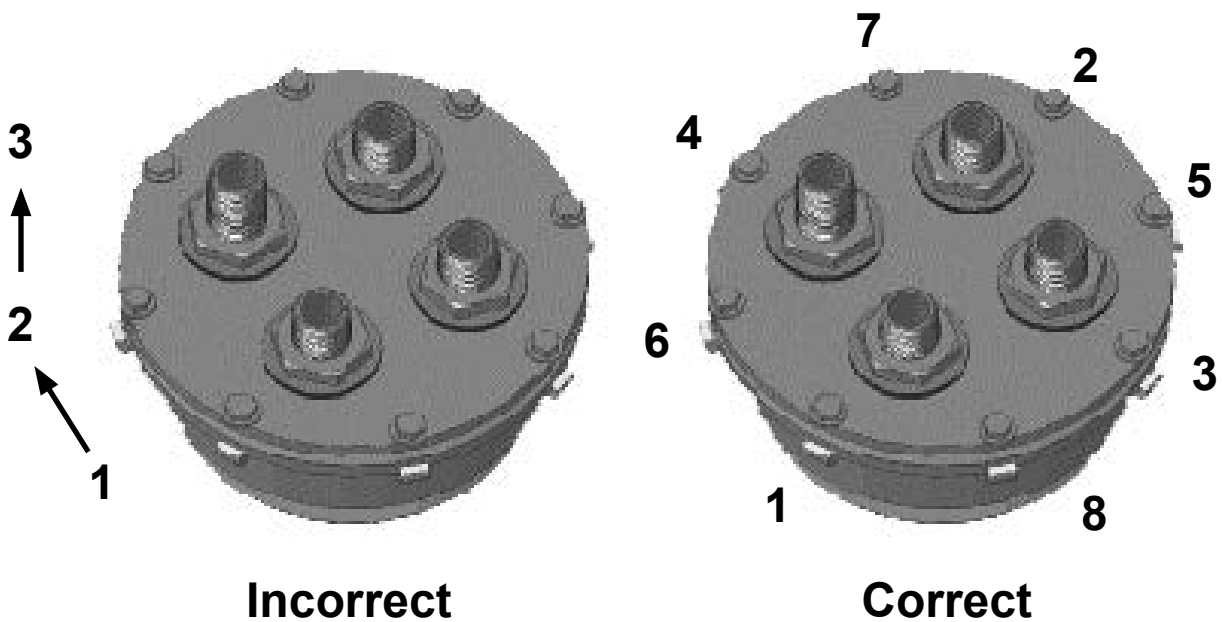

Figure 4: Coil Detail & Tightening Sequence

Proper Tightening Sequence for Top Mount Coil



Incorrect

Correct

Note: Same as car tire lugs

CAUTION: Does not require excessive force to seal properly.

9 Circulator & Burner Control Wiring Diagrams

Standard Wiring for Circulator with Boiler Maintaining a Temperature of 180°

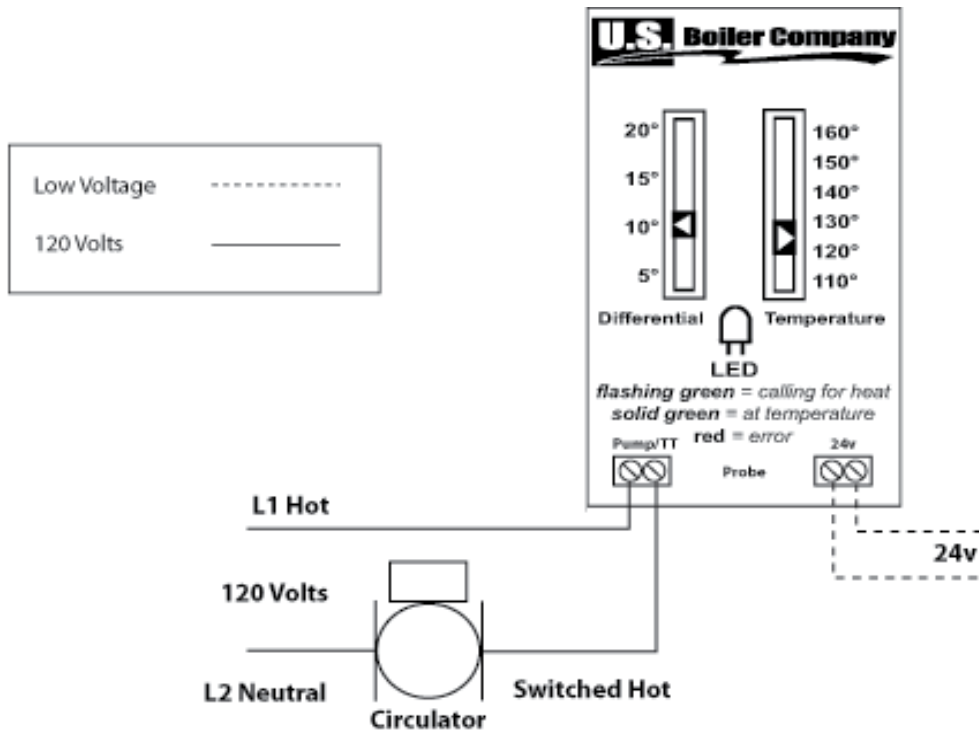

Wiring for Burner Control L8148E

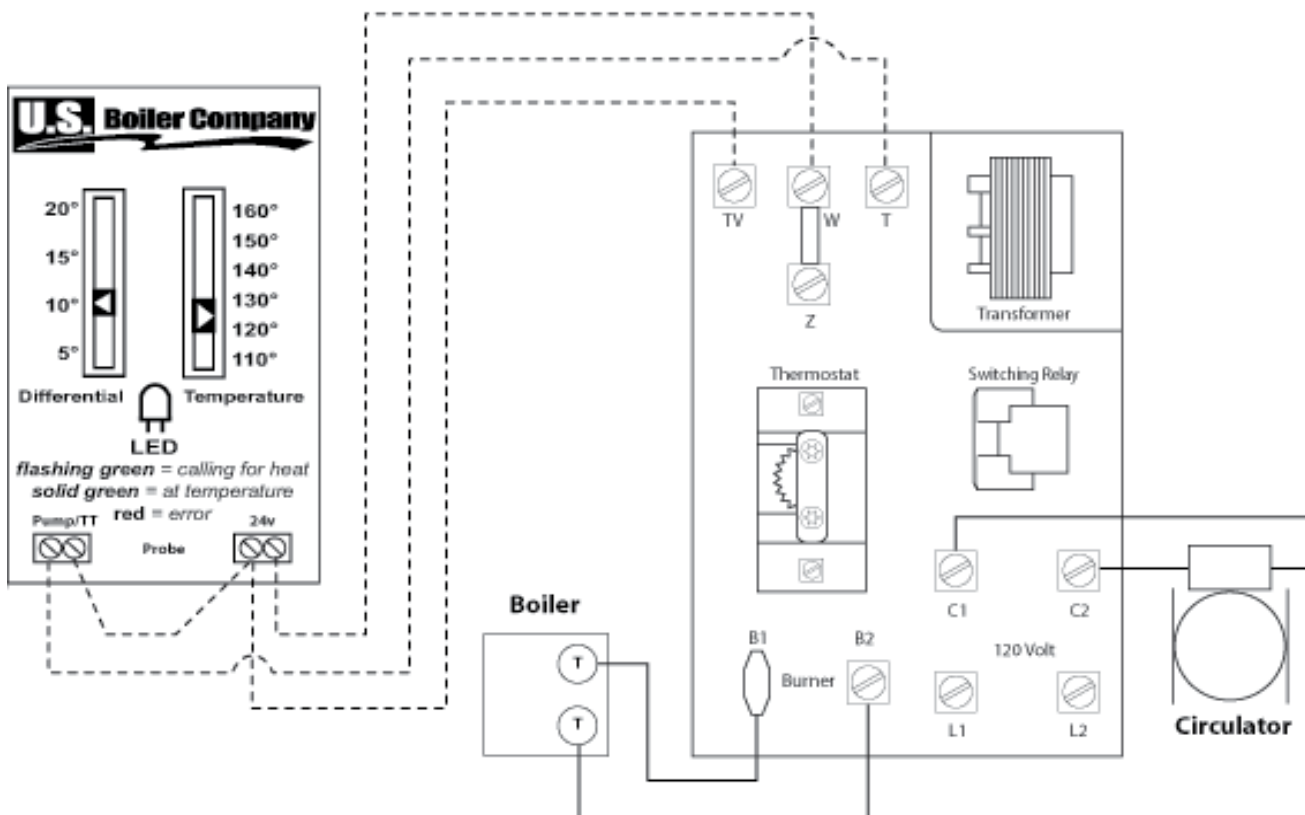

10 Zone Valve Wiring Diagrams

Wiring for 3 Wire Zone Valve

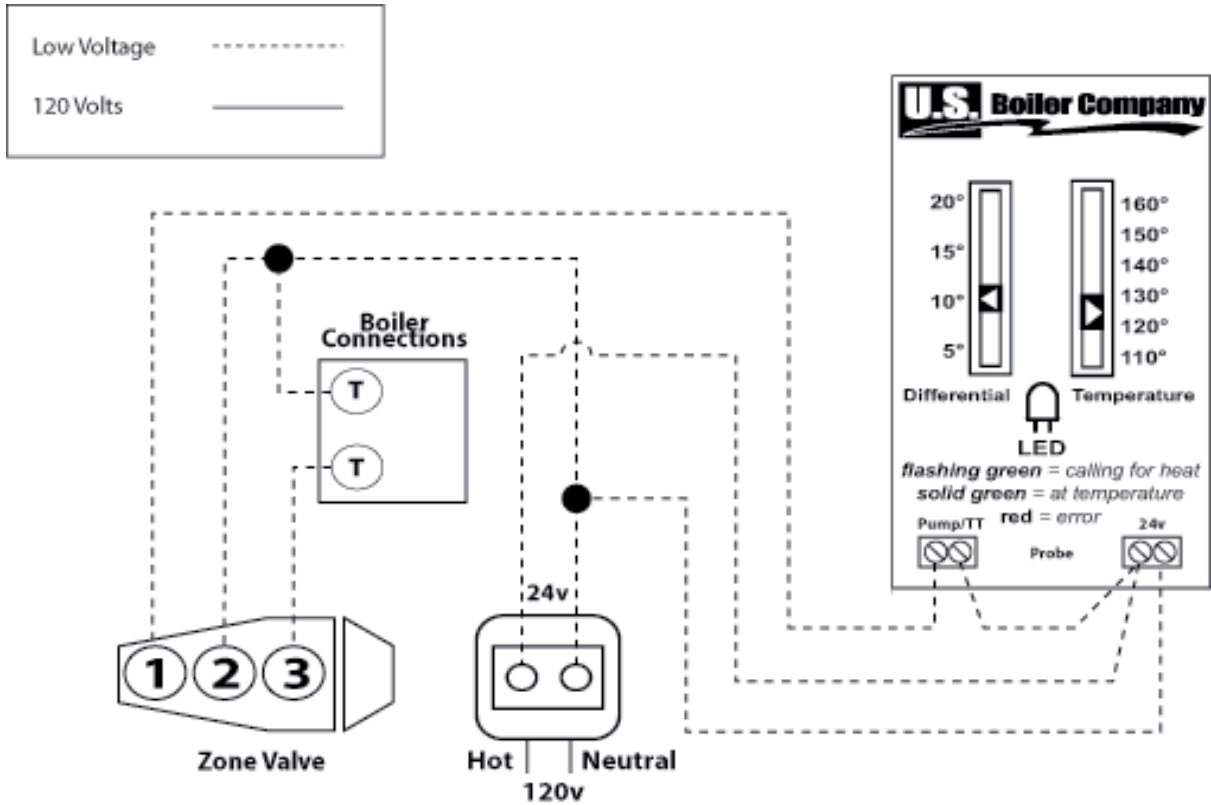

Wiring for 4 Wire Zone Valve

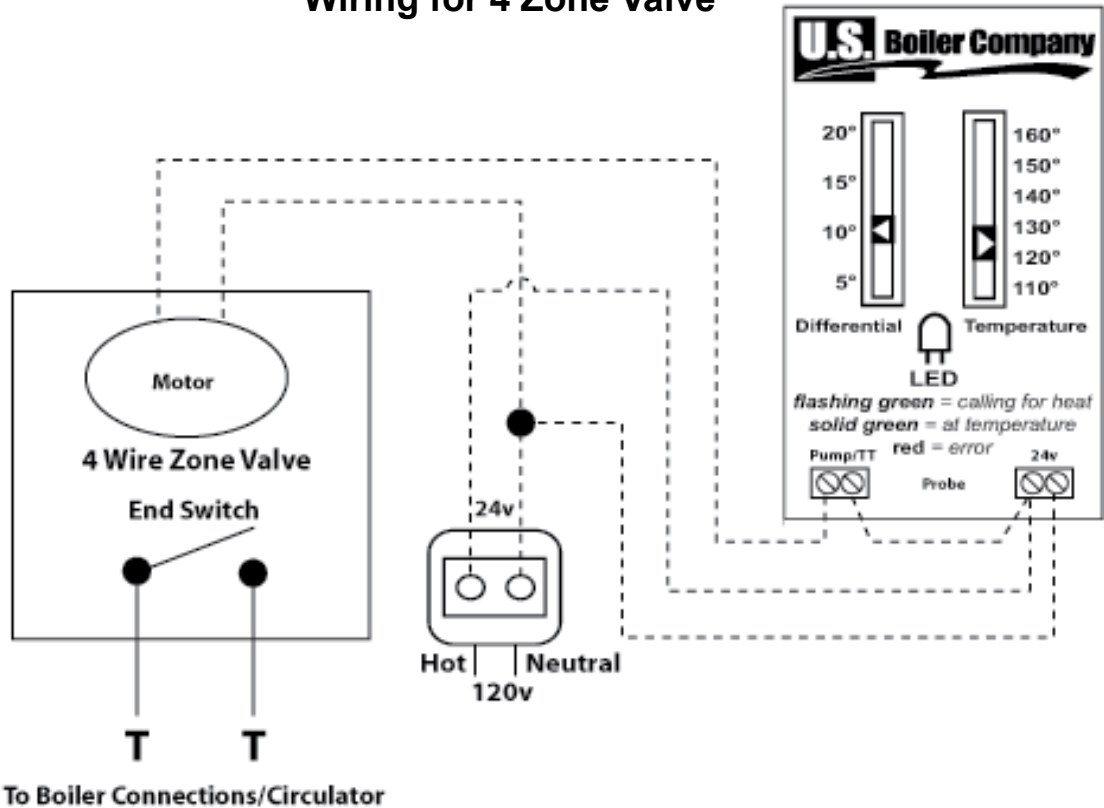

11 Switching Relay Wiring Diagrams

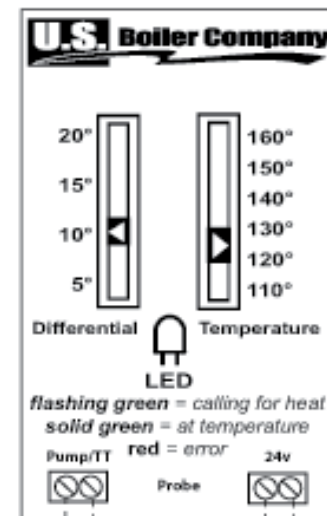
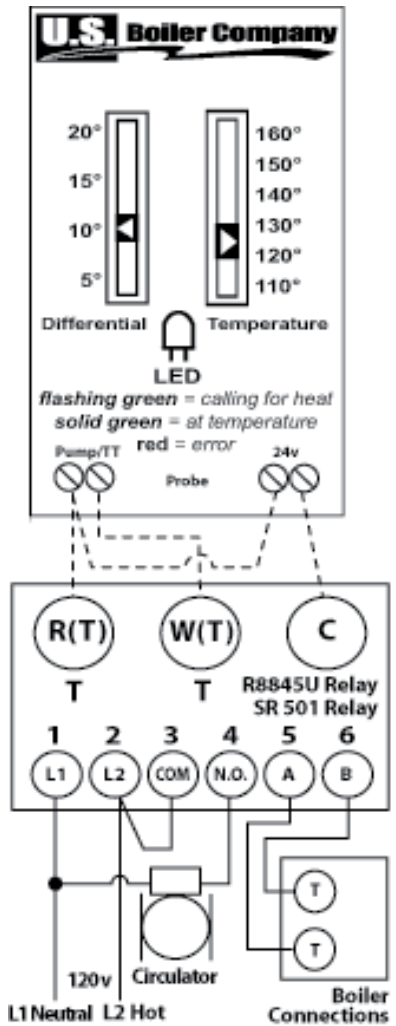

Switching Relay R8845U or SR 501

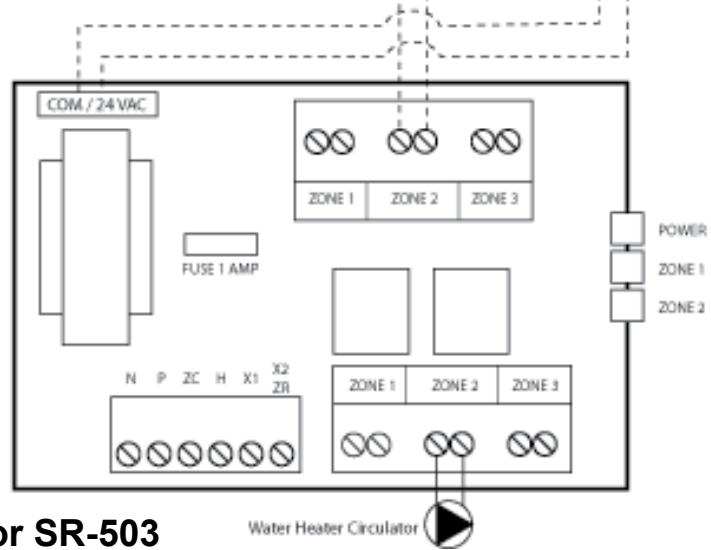

Switching Relay SR-502 or SR-503

11 Switching Relay Wiring Diagrams *(continued)*

Switching Relay SR-504 with Priority Option

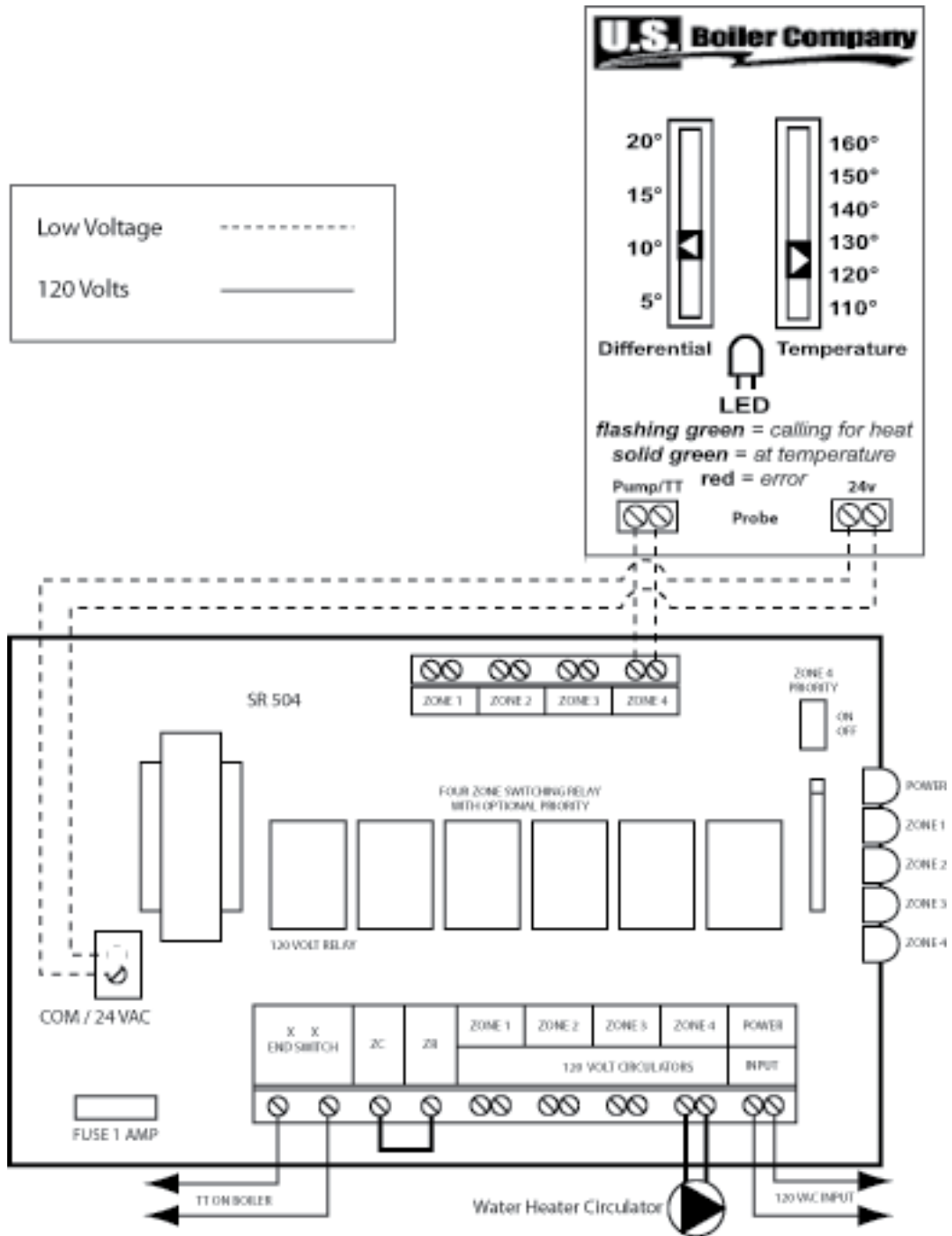

12 Service Parts

Item	Description	Part Number				
		AL27SL	AL35SL	AL50SL	AL70SL	AL70CSL
1	Replacement Coil Kit (includes Item 2 thru 8)		101484-01		101484-02	101484-04
2	Seal Deck			111963-01		
3	Immersion Well			105616-01		
4	Drain Valve			102802-01		
5	O-Ring 1-3/16 in.			111964-01		
6	Outer O-Ring 6-3/4 in.			101539-01		
	Inner O-Ring 6-1/4 in.					
7	Gasket Kit			107180-01		
8	Hardware Kit			101538-01		
	TPI Control			101379-01		
	T & P Relief Valve		101540-01			101540-02
	Black Plastic Coil Cover			102077-01		
	Coil Cover Insulation			102078-01		
	Replacement Misc. Parts Carton (Includes TPI Control, T&P Relief Valve, Plastic Coil/ Insulation)		101537-01			101537-03

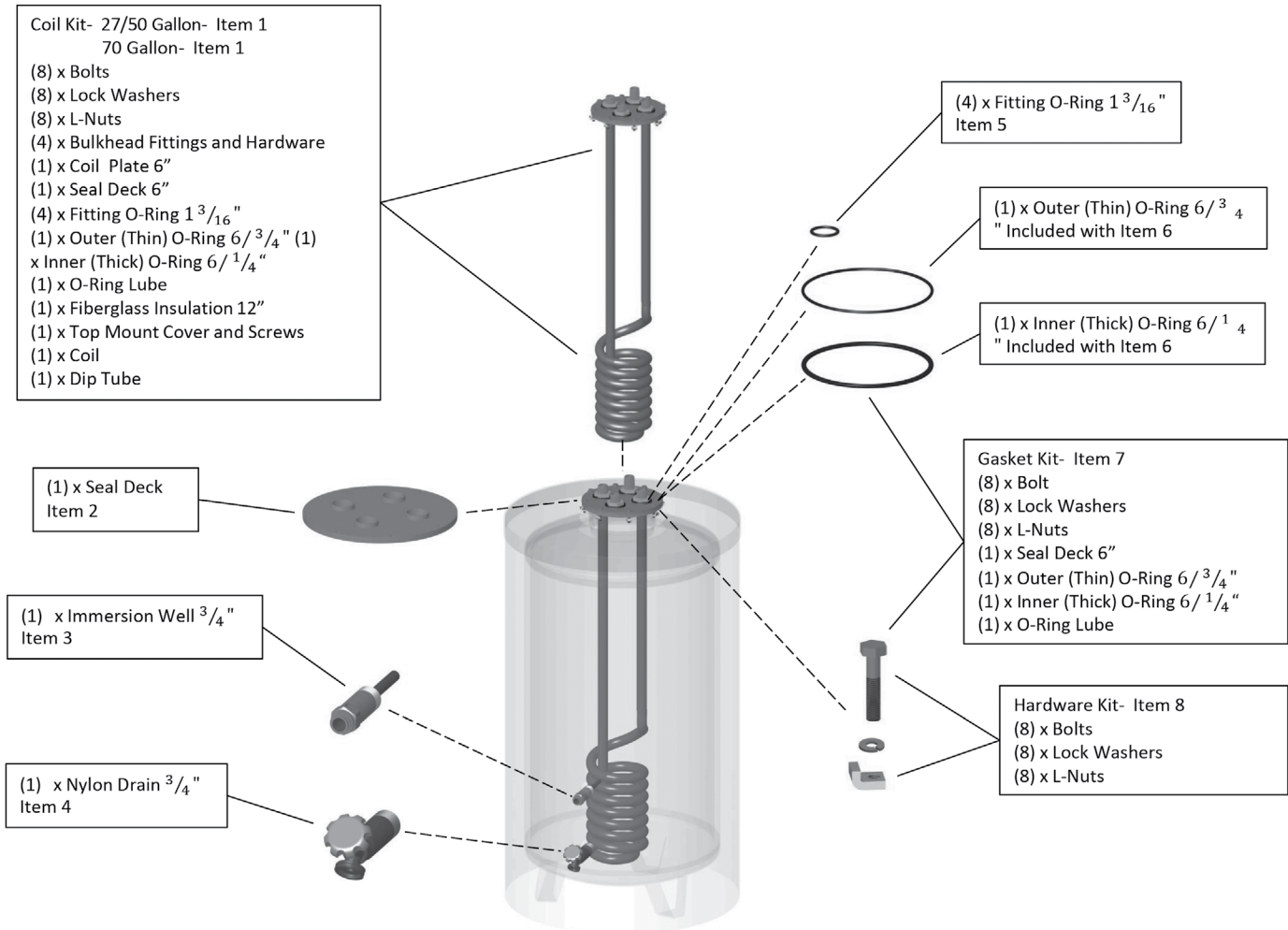

13 How To Obtain Service Assistance

U.S. Boiler Company, LLC does not have a service department or personnel to service your heater in the field. A qualified installer or service technician must do all service work. Therefore, if you have any questions about your new water heater concerning service adjustment, repair, routine maintenance, or replacement - **first contact your installer, plumbing contractor or service agency.**

In the event that the contractor, for whatever reason, is unable to help, refer to the telephone directory commercial listings for qualified service assistance.

If neither action has solved your problem, contact U.S. Boiler Company, LLC as follows to obtain the number of a qualified service person in your area:

SALES SUPPORT

U. B. BOILER COMPANY, LLC
P.O BOX 3020
LANCASTER, PA 17604
Or call 888-432-8887

When contacting U.S. Boiler Company the following information should be made available:

- A. Model and serial number of the water heater as listed on inside back cover of this manual or on the rating plate on the heater.**
- B. Address where water heater is installed.**
- C. Name and address of dealer from whom the heater was purchased and installer's name and address**
- D. Date of original installation and any service work performed since then.**
- E. Details of the problem as you can best describe.**
- F. List of people who have been contacted regarding the problem.**



www.usboiler.net

10-2-1 Limited Warranty

For Alliance SL™ and Alliance LT™ Indirect-Fired Water Heaters

Ten Year Limited Tank Replacement Warranty
Two Year Limited Tank Replacement Labor Allowance
One Year Limited Parts Warranty

U.S. Boiler Company, Inc. (hereinafter called the "Company") offers the following Limited Tank Replacement Warranty, Limited Tank Replacement Labor Allowance, and Limited Parts Warranty to the original purchaser/owner of this Alliance SL or Alliance LT indirect-fired water heater. These warranties are not transferable beyond the original purchaser/owner, and are not valid if the tank is removed from initial installation site. The Company reserves the right to require proof of purchase and inspection and/or testing of tank as a condition of these warranties.

TEN (10) YEAR LIMITED TANK REPLACEMENT WARRANTY DURATION:

- STANDARD DURATION:** Ten (10) years from the date of manufacture as indicated by the serial number.
- OPTIONAL LIFETIME DURATION:** Available to residential, single family homes only (excludes AL119SL, AL70CSL, AL80CLT, and AL119CLT) for as long as the original purchaser owns the home in which the Alliance SL or Alliance LT was originally installed. Optional Lifetime replacement Warranty is not effective unless U.S. Boiler Company, Inc. receives completed registration card and payment within 30 days of purchase (please see back cover of product manual for details).

IF NO CARD IS RETURNED OR PAYMENT RECEIVED, THE REPLACEMENT WARRANTY WILL BE THE STANDARD 10-YEAR WARRANTY AND WILL BEGIN FROM THE MANUFACTURED DATE INDICATED BY THE SERIAL NUMBER ON THE ALLIANCE SL WATER HEATER.

COVERAGE: Replacement warranty covers only the storage tank for leaks caused by the corrosive effects of water under normal and proper use. Subject to prior Company approval.

COMPANY OBLIGATION: Repair of the original tank or replacement of the entire heater with a new comparable model is at the option of the Company and constitutes the fulfillment of ALL obligations of the Company hereunder. In replacing or repairing the Alliance SL or Alliance LT water heater, the Company reserves the right to make such changes in details of design, construction or material as shall in their judgment constitute an improvement of former practices.

REPLACEMENT: When a replacement is made under the terms of this warranty, the replacement unit will have a warranty of replacement and labor allowance only for the remaining time under the original warranty. The Company reserves the right to require the return of the defective unit at the expense of the purchaser.

LIMITATION: The duration of the tank replacement warranty on the tank assembly shall be reduced to a period of five years if (1) the purchaser is a business, partnership or corporation, or if (2) the Alliance SL or Alliance LT water heater is used for a commercial, institutional, industrial, non-residential or multi-application, or (3) if the covered tank model is an AL119SL, AL70CSL, AL80CLT, or AL119CLT water heater, as these models are configured as commercial tanks and will always follow commercial warranty terms. All repairs or replacements will be made F.O.B. the Company. The purchaser must pay for transportation service, labor, installation, administrative fees or other costs involving the repair or replacement of such part.

YOUR ACTION: When you discover a defect, immediately notify the dealer from whom the heater was purchased. If you cannot locate the dealer, contact the Company.

TWO (2) YEAR LIMITED TANK REPLACEMENT LABOR ALLOWANCE:

The Company shall pay up to a maximum of \$200, for the labor to exchange a tank that is leaking due to the corrosive effects of water within two years from date of installation. This labor allowance is for tank replacement only, and not for any service work on the heater such as cleaning of the heat exchanger (due to the build-up of calcium or other minerals or metals), leakage from plumbing connections, relief valves, heat exchanger gaskets, thermostats, or any other component of the heater. This labor must be performed by a qualified installer. Proof of labor costs may be required as a condition of payment of the Tank Replacement Labor Allowance.

LIMITATION: All other repairs or replacements will be made F.O.B the Company. The purchaser must pay for all transportation, service, labor, installation, administrative fees or other cost involving the repair or replacement of such component parts.

YOUR ACTION: When you discover a defect, immediately notify the dealer from whom the heater was purchased. If you cannot locate the dealer, contact the Company.

ONE (1) YEAR LIMITED PARTS WARRANTY:

DURATION: The warranty is effective for one (1) year beginning with the date of original purchase. This warranty shall begin from the date of manufacture as indicated by the serial number.

COVERAGE: The warranty covers any component part of the Alliance SL or Alliance LT water heater proven to be defective in workmanship or material (subject to prior Company approval).

COMPANY OBLIGATION: The warranty covers any component of the Alliance SL or Alliance LT water heater proven to be defective in workmanship or material.

EXCLUSIONS AND LIMITATIONS:

Limited Warranty and Tank Replacement Warranty are valid only if you comply with the following conditions and limitations:

- The Alliance SL or Alliance LT water heater is correctly installed according to the installation manual provided with the unit and all applicable local and national codes.
- The unit is operated within the factory calibrated temperature limits and water pressure not exceeding 150 psi.
- Any failure or malfunction that does not result from improper or negligent operation, accident, abuse (including freezing), misuse, unauthorized alteration or improper maintenance.
- Any failure or malfunction that does not result from failure to keep the tank full of potable water, free to circulate at all times; and free of damaging water sediment or scale deposits. In areas where adverse water conditions are suspected (i.e. calcium and other minerals), it is essential that the water be tested and appropriate action be taken to prevent damage to the Alliance SL or Alliance LT tank. It may be necessary to remove the heat exchanger for cleaning to maintain maximum performance in poor water areas. Diminished performance due to the build-up of calcium or other minerals, metals, or deposits on the heat exchanger is specifically not included in the coverage of these warranties.
- THE FOREGOING EXPRESS LIMITED WARRANTIES ARE THE ONLY WARRANTIES OF ANY KIND, EITHER EXPRESS OR IMPLIED. THERE ARE NO EXPRESS OR IMPLIED WARRANTIES OF MERCHANTABILITY, FITNESS FOR A PARTICULAR PURPOSE, PERFORMANCE OR NON-INFRINGEMENT, OR OTHER EXPRESS OR IMPLIED WARRANTIES. EXCEPT FOR THE LIMITED WARRANTIES SET FORTH HEREIN, THE COMPANY DISCLAIMS ALL OTHER WARRANTIES OR CONDITIONS, EXPRESS OR IMPLIED, REGARDING THE PRODUCT OR ITS OR THEIR FITNESS FOR A PARTICULAR PURPOSE OR ITS OR THEIR MERCHANTABILITY. PURCHASER SHALL HAVE SOLE RESPONSIBILITY FOR SELECTING APPROPRIATE WATER HEATER FOR THE PURCHASER'S NEEDS AND USE AND THE COMPANY DOES NOT WARRANT THE FITNESS FOR THE WATER HEATER'S INTENDED USE WITHIN ANY SPECIFIC SYSTEM. THE COMPANY DOES NOT AUTHORIZE COMPANY REPRESENTATIVES OR OTHER PERSONS TO VARY THE TERMS OF THE WARRANTIES HEREIN OR TO ASSUME FOR THE COMPANY ANY OTHER OBLIGATIONS OR LIABILITIES WITH RESPECT TO THIS PRODUCT.
- The remedies set forth above shall be the sole and exclusive remedies for breach of any warranty.

IN NO EVENT SHALL THE COMPANY BE LIABLE FOR ANY INCIDENTAL OR CONSEQUENTIAL DAMAGES WHATSOEVER.

Consumer Notifications: The foregoing warranty limitations shall be effective to the maximum extent permitted by applicable law, and, to the extent that any such limitations would have an unconscionable result or would otherwise be inconsistent with applicable law, such provision shall be reformed to the extent necessary to avoid such unconscionable result or inconsistency. With respect to the limitations on implied warranties set forth above, the Company hereby notifies each person to whom such warranty is made as follows: Some states do not allow exclusions of such warranties, limitations on how long an implied warranty lasts or the exclusion or limitation of incidental or consequential damages, so the above limitations, or exclusions, may not apply to you. The limited warranty gives you specific legal rights, and you may also have other rights which vary from state to state.



U.S. Boiler Company, LLC
P.O. Box 3020, Lancaster PA 17604
Revised 12/22

U.S. Boiler Company, LLC
P.O. Box 3020
Lancaster, PA 17604
1-888-432-8887
www.usboiler.net