

INSTALLATION, OPERATING AND SERVICE INSTRUCTIONS FOR

MPO[®] 3-PASS OIL BOILER



For service or repairs to boiler, call your heating contractor or oil supplier. When seeking information on boiler, provide Boiler Model Number and Serial Number as shown on Rating Label located on top of the boiler.

Boiler Model Number MPO	Boiler Serial Number	Installation Date
Heating Contractor		Phone Number
Address		



IMPORTANT INFORMATION - READ CAREFULLY

All boilers must be installed in accordance with National, State and Local Plumbing, Heating and Electrical Codes and the regulations of the serving utilities. These Codes and Regulations may differ from this instruction manual. Authorities having jurisdiction should be consulted before installations are made.

In all cases, reference should be made to the following Standards:

USA BOILERS

- A. Current Edition of American National Standard ANSI/NFPA 31, "Installation of Oil Burning Equipment", for recommended installation practices.
- B. Current Edition of American National Standard ANSI/NFPA 211, "Chimneys, Fireplaces, Vents, and Solid Fuel Burning Appliances", For Venting requirements.
- C. Current Edition of American Society of Mechanical Engineers ASME CSD-1, "Controls and Safety Devices for Automatically Fired Boilers", for assembly and operations of controls and safety devices.
- D. All wiring on boilers installed in the USA shall be made in accordance with the National Electrical Code and/or Local Regulations.

CANADIAN BOILERS

- A. Current Edition of Canadian Standards Association CSA B139, "Installation Code for Oil Burning Equipment", for recommended Installation Practices.
- B. All wiring on boilers installed in Canada shall be made in accordance with the Canadian Electrical Code and/or Local Regulations.

The following terms are used throughout this manual to bring attention to the presence of hazards of various risk levels, or to important information concerning product life.

DANGER

Indicates an imminently hazardous situation which, if not avoided, will result in death, serious injury or substantial property damage.

CAUTION

Indicates a potentially hazardous situation which, if not avoided, may result in moderate or minor injury or property damage.

WARNING

Indicates a potentially hazardous situation which, if not avoided, could result in death, serious injury or substantial property damage.

NOTICE

Indicates special instructions on installation, operation, or maintenance which are important but not related to personal injury hazards.

NOTICE

This boiler has a limited warranty, a copy of which is printed on the back of this manual. The warranty for this boiler is valid only if the boiler has been installed, maintained and operated in accordance with these instructions.

Surface rust on cast iron sections may be attributed to the manufacturing process as well as condensation during storage. Surface rust is normal and does not affect the performance or longevity of a boiler.

DANGER

DO NOT store or use gasoline or other flammable vapors or liquids in the vicinity of this or any other appliance.

WARNING

Improper installation, adjustment, alteration, service or maintenance can cause property damage, personal injury or loss of life. Failure to follow all instructions in the proper order can cause personal injury or death. Read and understand all instructions, including all those contained in component manufacturers manuals which are provided with the appliance before installing, starting-up, operating, maintaining or servicing this appliance. Keep this manual and literature in legible condition and posted near appliance for reference by owner and service technician.

This boiler requires regular maintenance and service to operate safely. Follow the instructions contained in this manual.

Installation, maintenance, and service must be performed only by an experienced, skilled and knowledgeable installer or service agency.

All heating systems should be designed by competent contractors and only persons knowledgeable in the layout and installation of hydronic heating systems should attempt installation of any boiler.

Installation is not complete unless a pressure relief valve is installed into the 3/4" tapping located on return manifold that was installed into boss on top of rear section - See "Packaged Boiler Assy - Trim & Controls", "Unit-Pak Boiler Assy - Trim & Controls" and "Water Boiler Piping" Sections of this manual for details.

It is the responsibility of the installing contractor to see that all controls are correctly installed and are operating properly when the installation is completed.

This boiler is suitable for installation on combustible flooring. Do not install boiler on carpeting.

Do not tamper with or alter the boiler or controls.

Inspect flueways at least once a year - preferably at the start of the heating season. The inside of the combustion chamber, the vent system and boiler flueways should be cleaned if soot or scale has accumulated.

When cleaning this boiler, take precaution to avoid damage to burner swing door insulation. If damaged, or if there is evidence of previous damage, burner swing door insulation must be replaced immediately.

Oil Burner and Controls must be checked at least once a year or as may be necessitated.

Do not operate unit with jumpered or absent controls or safety devices.

Do not operate unit if any control, switch, component, or device has been subject to water.

Appliance materials of construction, products of combustion and the fuel contain alumina, silica, heavy metals, carbon monoxide, nitrogen oxides, aldehydes and/or other toxic or harmful substances which can cause death or serious injury and which are known to the state of California to cause cancer, birth defects and other reproductive harm. Always use proper safety clothing, respirators and equipment when servicing or working nearby the appliance.

WARNING

This boiler contains very hot water under high pressure. Do not unscrew any pipe fittings nor attempt to disconnect any components of this boiler without positively assuring the water is cool and has no pressure. Always wear protective clothing and equipment when installing, starting up or servicing this boiler to prevent scald injuries. Do not rely on the pressure and temperature gauges to determine the temperature and pressure of the boiler. This boiler contains components which become very hot when the boiler is operating. Do not touch any components unless they are cool.

This boiler must be properly vented. The chimney must be inspected for any obstructions and cleaned prior to each heating season. A clean and unobstructed chimney flue is necessary to produce the minimum draft required to safely evacuate noxious fumes that could cause personal injury or loss of life. Evidence of loose debris and or condensate induced stains at the base of the chimney flue, connector or smokepipe joints may be signs of condensing flue gases. Flue gas condensate is corrosive, which requires special consideration and must be addressed immediately. Refer to Section VI, "Venting" or Section VII "Direct Venting / Air Intake Piping".

This boiler needs fresh air for safe operation and must be installed so there are provisions for adequate combustion and ventilation air.

This boiler is supplied with controls which may cause the boiler to shut down and not re-start without service. If damage due to frozen pipes is a possibility, the heating system should not be left unattended in cold weather; or appropriate safeguards and alarms should be installed on the heating system to prevent damage if the boiler is inoperative.

This boiler is designed to burn No. 2 fuel oil only. Do not use gasoline, crankcase drainings, or any oil containing gasoline. Never burn garbage or paper in this boiler. Do not convert to any solid fuel (i.e. wood, coal). Do not convert to any gaseous fuel (i.e. natural gas, LP). All flammable debris, rags, paper, wood scraps, etc., should be kept clear of the boiler at all times. Keep the boiler area clean and free of fire hazards.

All boilers equipped with burner swing door have a potential hazard which, if ignored, can cause severe property damage, personal injury or loss of life. Before opening swing door, unplug burner power cord from receptacle located in lower right corner of jacket front panel and turn off service switch to boiler to prevent accidental firing of burner outside the combustion chamber. Be sure to tighten swing door fasteners completely when service is completed.

TABLE OF CONTENTS

I. Pre-Installation	8	IX. Oil Piping	48
II. Packaged Boiler Assy. - Trim & Controls	11	X. System Start-Up	50
III. Unit-Pak Boiler Assy. - Trim & Controls.....	23	XI. Maintenance & Service Instructions	62
IV. Water Boiler Piping	30	XII. Boiler Cleaning	64
V. Indirect Water Heater Piping	34	XIII. Trouble Shooting	66
VI. Venting	35	XIV. Repair Parts	67
VII. Direct Venting / Air Intake Piping.....	39	XV. Appendix	
VIII. Electrical	45	Low Water Cut Off.....	82

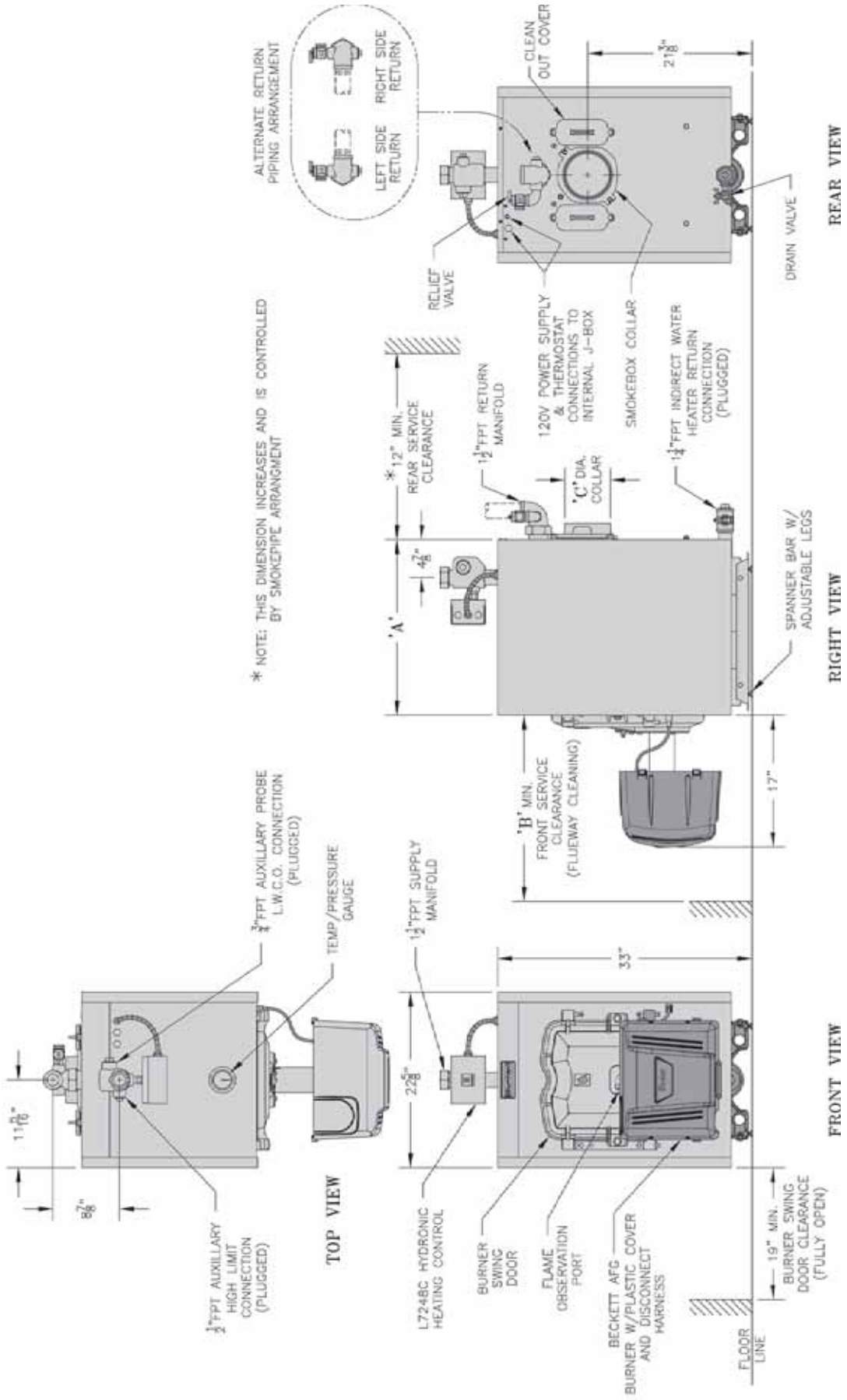

Figure 1: MPO 84 Thru MPO 231 Water Boiler

TABLE 1A: DIMENSIONAL DATA (SEE FIGURE 1)

Boiler Model No.	Dimensions See Figure 1			Water Content - Gallons	Heat Transfer Surface Area - Sq. Ft.	Actual Shipping Weight (LB.)
	"A"	"B"	"C"			
MPO84	16-5/8"	24"	5"	7.70	13.29	430
MPO115	16-5/8"	24"	5"	7.70	13.29	430
MPO147	22-5/8"	24"	6"	11.08	20.29	545
MPO189	28-5/8"	30"	6"	14.46	27.29	658
MPO231	34-5/8"	36"	7"	17.84	34.29	771

NOTE: 1. Maximum Working Pressure: Water: 30 PSI Shipped From Factory (Standard),
40 PSI Optional, 50 PSI Optional

TABLE 1B: RATING DATA

Boiler Model No.	Burner Capacity			I=B=R NET Ratings	Minimum Chimney Requirements			Direct Vent System		AFUE %
	GPH	MBH	DOE Heating Capacity MBH		Water MBH	Round In. Dia.	Rectangle In. x In.	Height Ft.	Model	
MPO84	0.60	84	74	64	6	8 x 8	15		N/A	87
MPO115	0.82	115	101	87	6	8 x 8	15		N/A	87
MPO147	1.05	147	129	112	6	8 x 8	15	FDVS-56	5	87
MPO189	1.35	189	167	145	7	8 x 8	15	FDVS-56	5	87
MPO231	1.65	231	203	177	7	8 x 8	15	FDVS-67	6	87

SECTION I: PRE-INSTALLATION

A. INSPECT SHIPMENT carefully for any signs of damage.

1. All equipment is carefully manufactured, inspected and packed. Our responsibility ceases upon delivery of crated boiler to the carrier in good condition.
2. Any claims for damage or shortage in shipment must be filed immediately against the carrier by the consignee. No claims for variances from, or shortage in orders, will be allowed by the manufacturer unless presented within sixty (60) days after receipt of goods.

B. LOCATE BOILER in front of final position before removing crate. See Figure 1.

1. LOCATE so that vent pipe connection to chimney will be short and direct.
2. BOILER IS SUITABLE FOR INSTALLATION ON COMBUSTIBLE FLOOR. Boiler cannot be installed on carpeting.
3. FOR BASEMENT INSTALLATION, provide a solid elevated base, such as concrete, if floor is not level, or if water may be encountered on floor around boiler.
4. PROVIDE RECOMMENDED SERVICE CLEARANCE, if applicable, as follows:
 - a. Clearance from Jacket Front Panel -
 - 24" for servicing burner
 - 24" for flueway cleaning (MPO84 thru 147)

- 30" for flueway cleaning (MPO189)
 - 36" for flueway cleaning (MPO231)
- b. Clearance from Jacket Left Side Panel -
 - 19" for burner swing door, if opened fully with burner mounted, otherwise 1" with burner removed
 - 12" access clearance to service rear of boiler if right side clearance is less than 12"
 - 3" minimum if right side clearance is 12" or larger to access and service rear of boiler.
 - c. Clearance from Jacket Right Side Panel -
 - 3" minimum if left side clearance is 12" or larger to access and service rear of boiler.
 - d. Clearance from Jacket Rear Panel -
 - 12" minimum for rear smokebox cleaning (Note: This dimension will also be controlled by horizontal to vertical to horizontal smokepipe arrangement - **Chimney Vent** (see Figures 2A and 21).
 - 24" for rear smokebox cleaning and disconnecting vent pipe from appliance adapter for servicing (if required) - **Direct Vent** (see Figure 2B).
5. For minimum clearances to combustibles materials. See Figures 2A and 2B.

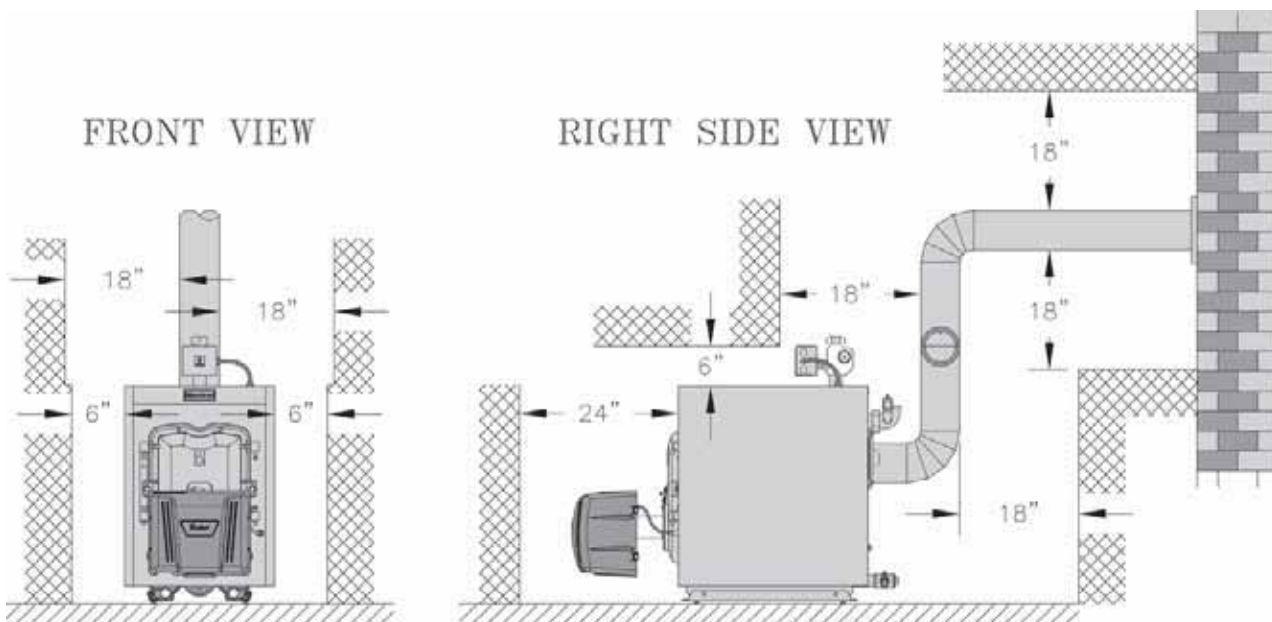

Figure 2A: Chimney Minimum Installation Clearances To Combustible Materials (Inches)

NOTES:

1. Listed clearances comply with American National Standard ANSI/NFPA 31, Installation of Oil Burning Equipment.
2. MPO® boilers can be installed in rooms with clearances from combustible material as listed above. Listed clearances cannot

- be reduced for alcove or closet installations.
- 3. For reduced clearances to combustible material, protection must be provided as described in the above ANSI/NFPA 31 standard.

NOTICE

Clearance to venting is for single wall vent pipe. If Type L vent is used, clearance may be reduced to the minimum required by the vent pipe manufacturer.

- C. **PROVIDE COMBUSTION AND VENTILATION AIR.** Local and National Codes may apply and should be referenced.

WARNING

Adequate combustion and ventilation air must be provided to assure proper combustion and to maintain safe ambient air temperatures.

Do not install boiler where gasoline or other flammable vapors or liquids, or sources of hydrocarbons (i.e. bleaches, fabric softeners, etc.) are used or stored.

1. Determine volume of space (boiler room). Rooms communicating directly with the space in which the appliances are installed, through openings not furnished with doors, are considered a part of the space.
Volume(ft³) = Length(ft) x Width(ft) x Height(ft)
2. Determine total input of all appliances in the space. Add inputs of all appliances in the space and round the result to the nearest 1000 BTU per hour.
3. Determine type of space. Divide Volume by total input of all appliances in space. If the result is greater than or equal to 50 ft³/1000 BTU per hour, then it is considered an *unconfined space*. If the result is less than 50 ft³/1000 BTU per hour then the space is considered a *confined space*.
4. For boiler located in an *unconfined space of a conventionally constructed building*, the fresh air infiltration through cracks around windows

and doors normally provides adequate air for combustion and ventilation.

5. For boiler located in a confined space or an unconfined space in a building of *unusually tight construction*, provide outdoor air.
 - a. Outdoor air for combustion may be provided with an optional Burnham V8H™ Fresh Air Accessory Kit (**ONLY AVAILABLE WITH BECKETT BURNER**). Metal cover applications, P/N 611280031. Plastic cover applications, P/N 102119-01. Refer to Fresh Air Accessory Kit instructions for installation and air intake piping details. See Section VI for installation details.

or
 - b. Outdoor air may be provided with the use of two permanent openings which communicate directly or by duct with the outdoors or spaces (crawl or attic) freely communicating with the outdoors. Locate one opening within 12 inches of top of space. Locate remaining opening within 12 inches of bottom of space. Minimum dimension of air opening is 3 inches. Size each opening per following:
 - i. **Direct communication with outdoors.**
Minimum free area of 1 square inch per 4,000 BTU per hour input of all equipment in space.
 - ii. **Vertical ducts.** Minimum free area of 1 square inch per 4,000 BTU per hour input of all equipment in space. Duct cross-sectional area shall be same as opening free area.
 - iii. **Horizontal ducts.** Minimum free area of 1 square inch per 2,000 BTU per hour input of all equipment in space. Duct cross-sectional area shall be same as opening free area.

Alternate method for boiler located within confined space. Use indoor air if two permanent openings communicate directly

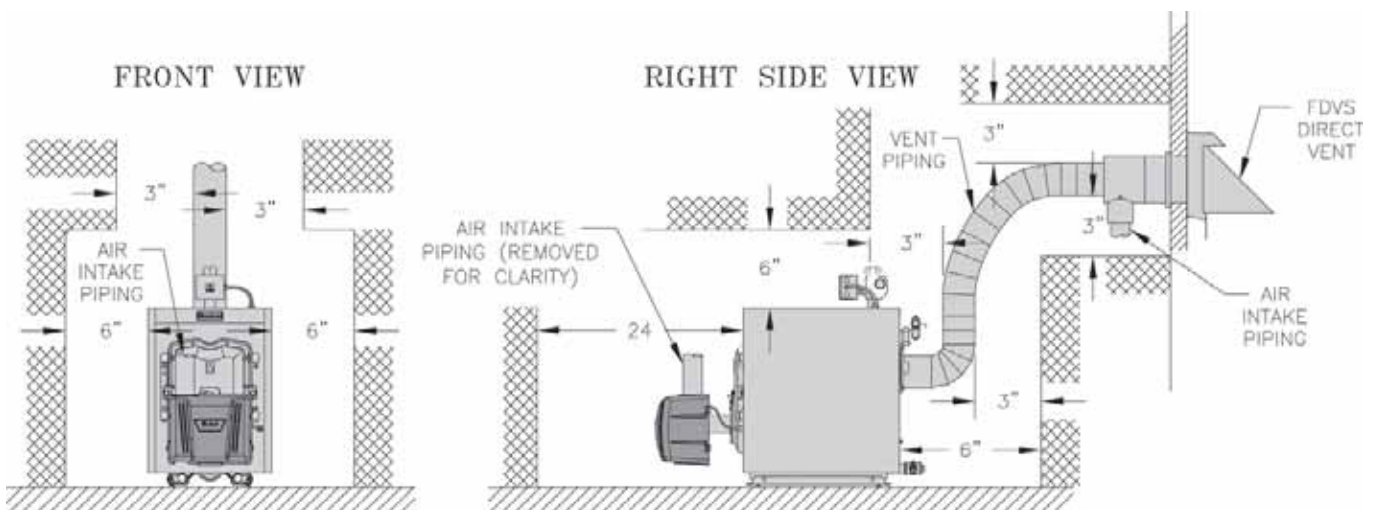

Figure 2B: Direct Vent Minimum Installation Clearances To Combustible Materials (Inches)

with additional space(s) of sufficient volume such that combined volume of all spaces meet criteria for unconfined space. Size each opening for minimum free area of 1 square inch per 1,000 BTU per hour input of all equipment in spaces, but not less than 100 square inches.

6. Louvers and Grilles of Ventilation Ducts

- a. All outside openings should be screened and louvered. Screens used should not be smaller than 1/4 inch mesh. Louvers will prevent the entrance of rain and snow.
- b. Free area requirements need to consider the blocking effect of louvers, grilles, or screens protecting the openings. If the free area of the louver or grille is not known, assume wood louvers have 20-25 percent free area and metal louvers and grilles have 60-75 percent free area.
- c. Louvers and grilles must be fixed in the open position, or interlocked with the equipment to open automatically during equipment operation.

D. DIRECT VENT CONFIGURATIONS requires:

- 1. Beckett NX Burner
- 2. Direct Vent Conversion Kit
- 3. Double Wall Flex Oil Vent Pipe (FOVP)

TABLE 2: DIRECT VENT CONFIGURATION COMPONENTS

Boiler Model No.	Beckett NX Oil Burner Part No.	Direct Vent Conversion Kit Part No.	FOVP Carton Part No.
MPO147	100240-02	102130-02	100211-02 - 5 ft.
			100212-02 - 10 ft.
MPO189	100240-03		100213-02 - 15 ft.
			100214-02 - 20 ft.
MPO231	100240-04	102130-03	100211-03 - 5 ft.
			100212-03 - 10 ft.
			100213-03 - 15 ft.
			100214-03 - 20 ft.

SECTION II: PACKAGED BOILER ASSEMBLY - TRIM & CONTROLS

A. REMOVE CRATE.

1. Remove all fasteners at crate skid.
2. Lift outside container and remove all other inside protective spacers and bracing. Remove miscellaneous parts carton.

B. REMOVE BOILER FROM SKID.

1. To reduce the risk of damage to boiler jacket, use the following procedure to remove from skid, see Figure 3:

Step 1. Boiler is secured to base with (4) 5/16" cap screws, (2) in front and (2) in rear of shipping skid, see Figure 3. Remove all securing hardware.

Step 2. Place wooden block(s) 12" from rear of skid as shown (one piece 4" x 4" x 16" lg. or two pieces of 2" x 4" x 16" lg.)

Step 3. Insert 1" Sch. 40 pipe handles through leg hole in front and rear legs. Center end of pipe on wooden blocks as shown in Figure 3.

NOTE: Pipe handles should extend a minimum of 48" beyond jacket front panel for best leverage.

Step 4. Using the pipe handles, lift boiler until adjustable legs are elevated above the deck boards.

Step 5. Remove skid from underneath the boiler.

Step 6. Lower pipe handles until front adjustable legs touch floor. If necessary, place wooden

blocks under front legs before lowering to provide hand clearance.

Step 7. To lower rear of boiler, tilt unit slightly forward by pushing on smokebox collar or lift pipes protruding through rear legs until wooden blocks can be removed (see Figure 3). Slowly allow the weight of the boiler to tilt backward until rear legs rest on floor.

Step 8. If wood block was placed under front legs, lift pipe handles, remove wooden block and lower front legs to floor. Remove pipe handles.

CAUTION

Do not drop boiler. Do not bump boiler jacket against floor.

C. **MOVE BOILER TO PERMANENT POSITION** by sliding or walking.

D. PROCEDURE TO OPEN, CLOSE AND SECURE BURNER SWING DOOR

Throughout this manual you will be instructed to open and close the burner swing door for various reasons. There is a proper and improper method to closing and securing the burner swing door opened for inspection, cleaning or field service.

1. TO OPEN BURNER SWING DOOR

(see Figures 4A and 4B).

Step 1. Loosen but do not remove left side latching hardware (3/8" x 1-3/4" lg. tap bolt).

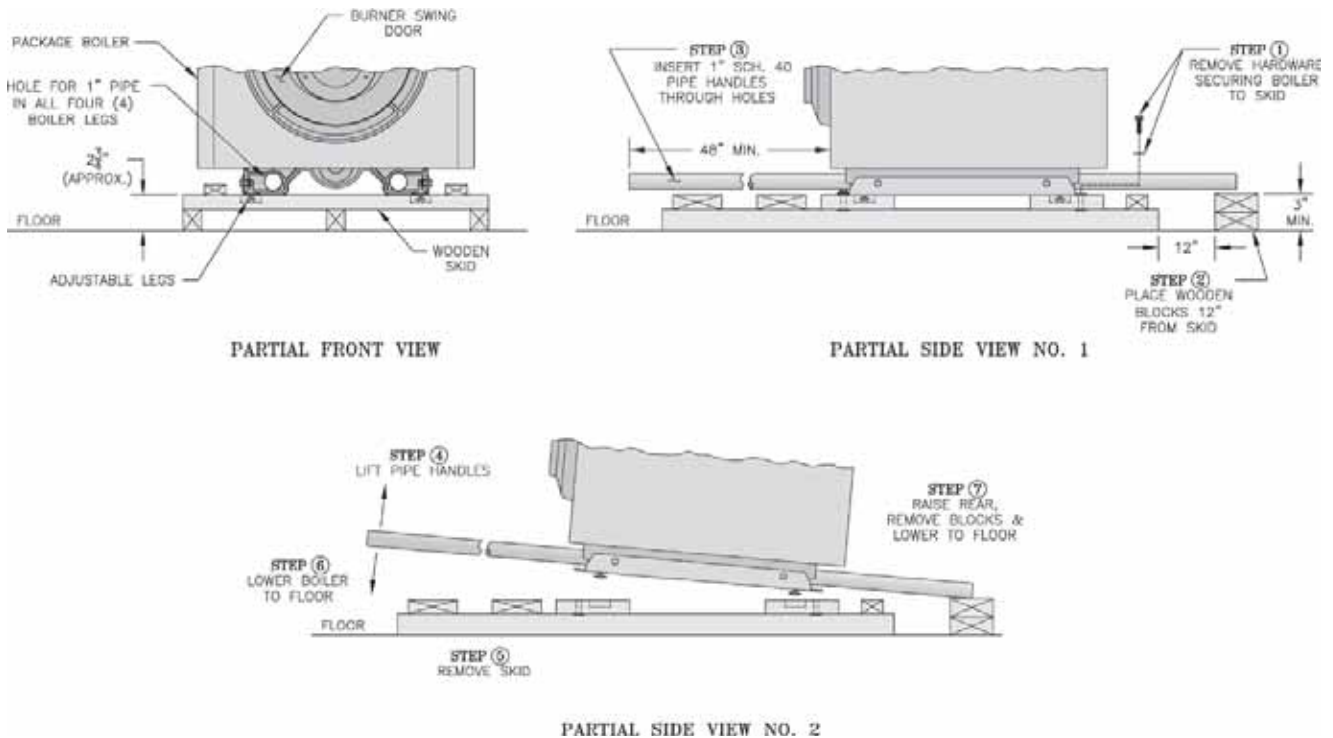

Figure 3: Packaged Boiler Removal from Skid

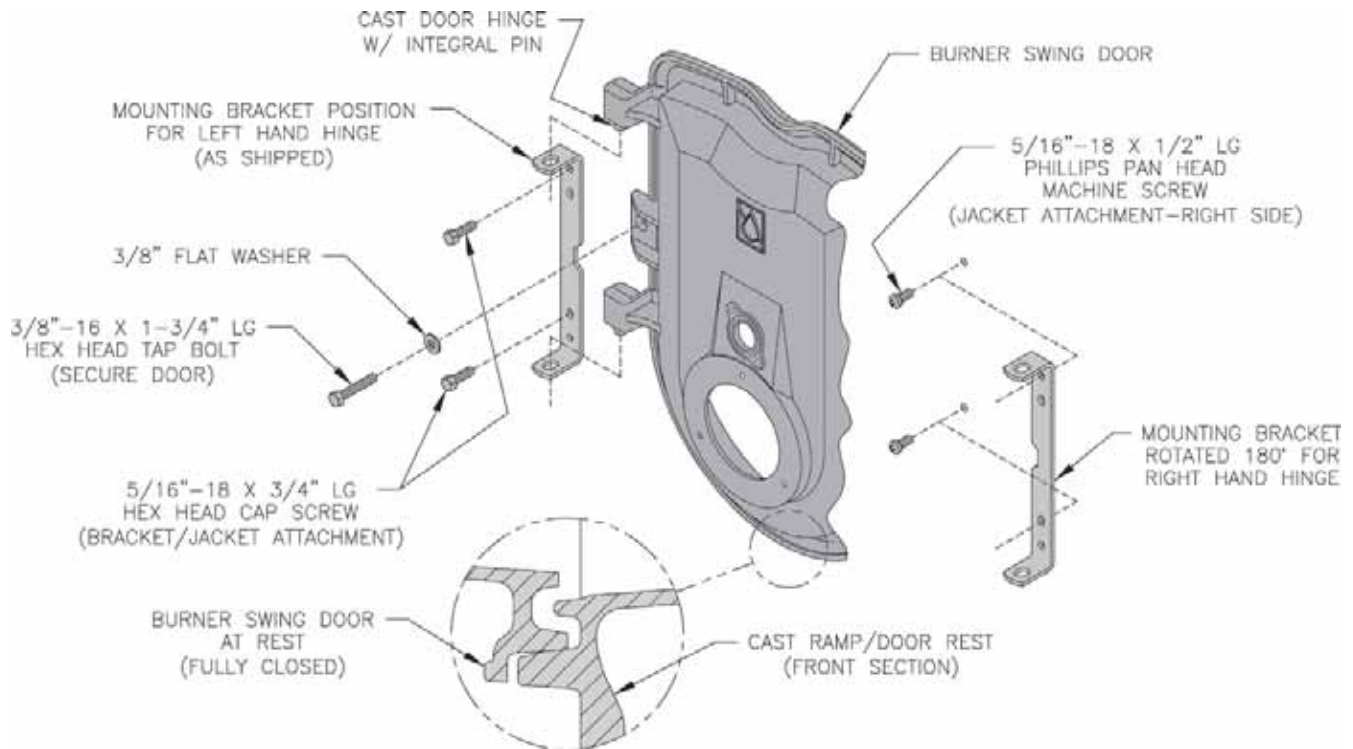

Figure 4A: Partial Front View - Burner Swing Door Mounted to Boiler - Fully Closed and Secured

Step 2. Loosen and remove right side latching hardware (3/8" x 1-3/4" lg. tap bolt and washer).

Step 3. Remove left side latching hardware (3/8" x 1-3/4" lg. tap bolt and washer).

Step 4. Disconnect burner power cord from receptacle located in lower right corner of jacket front panel.

Step 5. Door can be swung to the fully open position, approximately 90° to 120°, with the burner mounted providing that there is 19" of clearance to the adjacent wall, see Figure 1.

NOTE: If reduced clearance prevents the door from opening fully, one of the following can provide full access:

- Burner can be removed to allow full rotation of door.
- Door with burner mounted can be lifted off mounting bracket and set aside during servicing.
- The door mounting hardware is reversible from left side hinge (as shipped) to right side hinge.

To reverse hinge arrangement (see Figure 4A):

- Lift door off mounting bracket and set aside.
- Remove mounting bracket and hardware from left side.

- Remove upper jacket front panel retaining screw (5/16" x 1/2" lg. Phillip Pan head machine screw) from right side of door and re-install in vacated upper mounting bracket tapping. Do not tighten.

- Move lower jacket panel retaining screw from right side to left tapping. Do not tighten.

- Rotate door mounting bracket 180°. Insert 5/16" cap screw through top hole in bracket and install in upper vacated jacket hole on right side of door.

- Install second 5/16" cap through bracket hole into lower vacated tapping on right side.

- Tighten both sets of hardware to secure jacket and mounting bracket.

- Lift door and place integral cast hinge pins on door into slotted mounting bracket holes.

- Perform routine inspection, service or cleaning as necessary.

- To close Burner Swing Door (see Figures 4A and 4B):

Step 1. From the fully open position, rotate Burner Swing Door to the closed position.

Step 2. If necessary, place your right hand under the burner air tube to lift upward. Lift the door up unto the built-in cast ramp/door rest

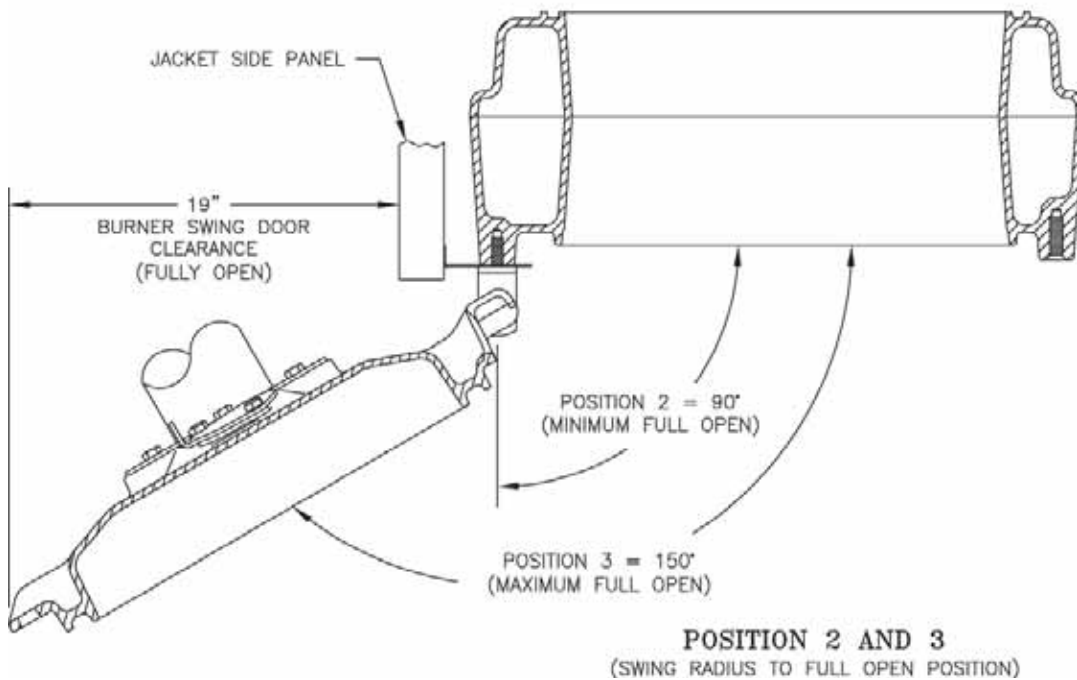
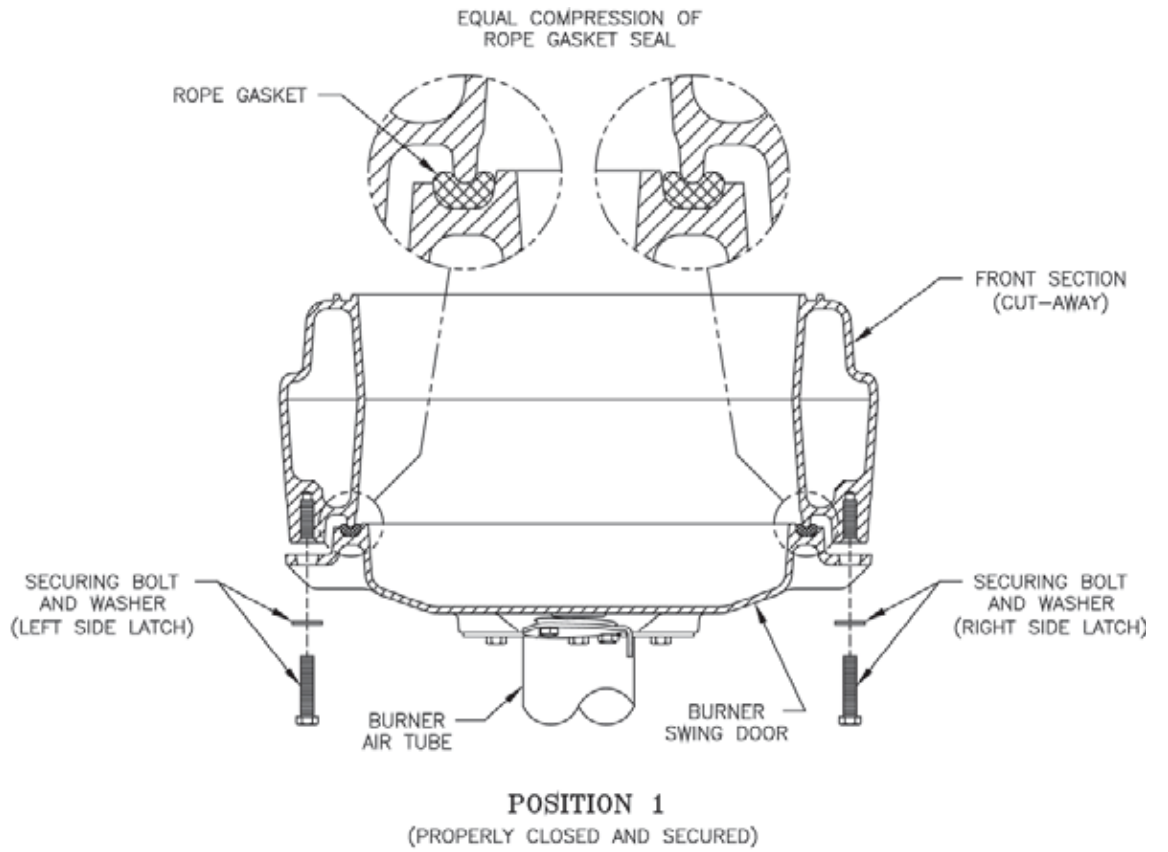

Figure 4B: Top View - Burner Swing Door Mounted to Cast Iron Block Assembly (Jacket Removed for Clarity)

(protruding from the bottom of the front section casting - see Figure 4A).

Step 3. Use one hand to help hold door in position by lifting up on rear burner housing or applying pressure directly to the door while re-installing the securing hardware with your opposite hand. **Always install right side latching hardware (3/8"-16 x 1-3/4" lg. tap bolt and flat washer) first**, then install left side hinge hardware (3/8"-16 x 1-3/4" lg. tap bolt and flat washer) **second**. Apply additional pressure while hand tightening the hardware as far as possible, then release the pressure.

NOTICE

When securing burner swing door make sure door is drawn-in equally on both sides.

Step 4. Use a hand wrench to tighten door hardware and **always start with the right side cap screw first**. Use an alternating tightening method from right side tap bolt to left side tap bolt to tighten door equally until sealed without applying excessive torque. **Never** tighten left side flange bolt first or tighten either piece of hardware 100% without using the alternating tightening method described above.

Failure to follow the prescribed procedure could cause thread damage to casting or a leak in the door seal. If left side tap bolt is tightened before right side tap bolt, right side of door can not be drawn-in to provide an air tight seal, as shown in Figure 4C. Applying excessive torque will only cause thread damage.

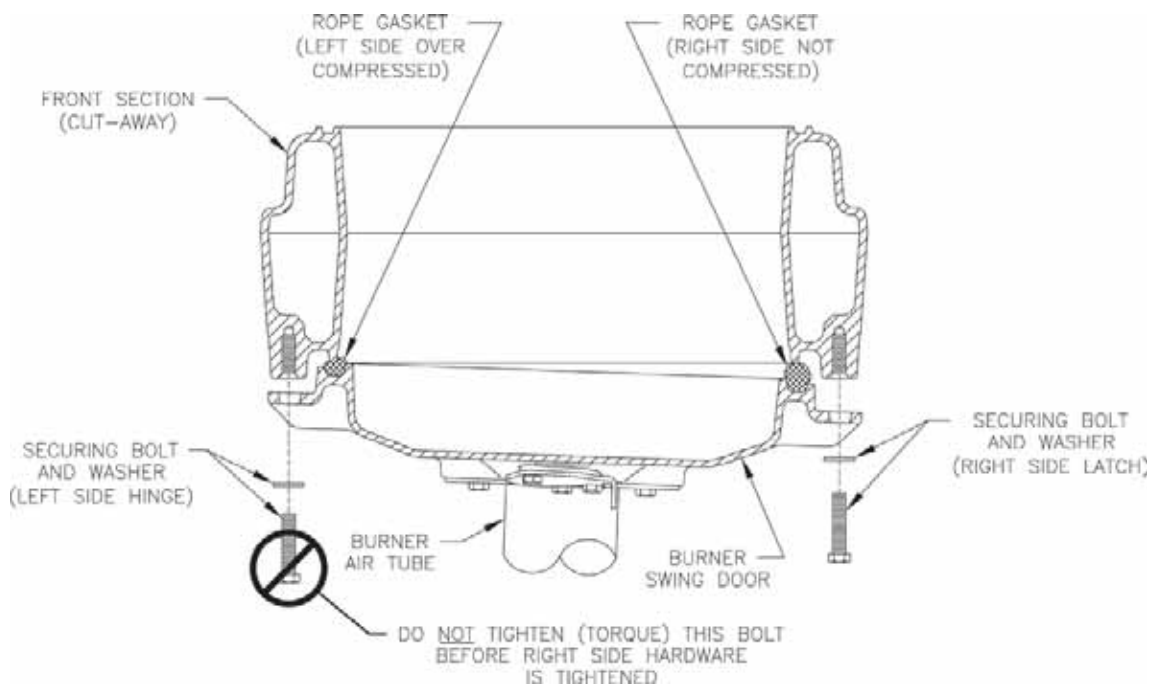

Figure 4C: Top View - Burner Swing Door Fully Closed but Not Properly Secured or Sealed

E. INSPECT SWING DOOR INSULATION AND ROPE GASKET.

1. Open burner swing door using procedure previously outlined in Paragraph D of this section.
2. Inspect fiberglass rope located on the swing door. The rope must be evenly distributed around the perimeter of the door groove and cannot bunch or overhang. There must not be a gap where the two ends of the rope meet. Repair or replace if the rope is damaged or if there is a gap between the ends.
3. Inspect burner swing door insulation for damage and proper type.
 - a. By design, cast bars on front section between the combustion chamber and between the left and right side 2nd and 3rd pass flueway should make an impression in door insulation to seal the chambers.
 - b. By design, door insulation on model MPO231 will have two (2) by-pass pockets cast into the insulation centered on the bar between the combustion chamber and 3rd pass flueways. On models MPO84 thru MPO189 these pockets should not be present. If insulation is damaged or not of proper type regarding pockets, it must be replaced.
4. Do not close and secure door at this time, proceed to Field Assembly Details, Paragraph F.

F. FIELD ASSEMBLY OF BOILER TRIM AND CONTROLS

Open miscellaneous parts carton and remove contents. Identify the components using the illustrations (Figures

5 thru 12) throughout the assembly sequence outlined below as it applies to your installation.

1. Install supply manifold and aquastat control, refer to Figure 5.

Step a. Remove two (2) #8 x 1/2" lg. sheet metal screws securing jacket **top rear** panel to jacket **rear** panel. Slightly lift and pull jacket **top rear** panel away from jacket **top** panel to gain access to internal J-box wiring harness.

Step b. Locate the cast iron supply manifold shown in Figure 5. Apply thread sealant to 1-1/2" NPT male threads. Thread male end into 1-1/2" NPT top tapping on rear section. Using hex head on top, tighten manifold until 1/2" NPT boss for control well is facing forward and joint is water tight.

Step c. Locate 1/2" NPT x 1-1/2" immersion well. Apply thread sealant to 1/2" NPT male threads. Thread well into 1/2" NPT boss on front of supply manifold. Using hex head, tighten well until water tight.

Step d. Locate L7248C Aquastat Control/Harness Assembly. Loosen mounting screw on bottom of case. Insert sensor into immersion well. Mount control on immersion well and tighten screw to secure control in horizontal position with harness on right side as shown in Figure 5.

Step e. Insert two (2) brown thermostat wires and three (3) aquastat wires with Molex socket connector located on opposite end of aquastat harness through 7/8" dia. blank knockout in jacket **top** panel. Fish these wires to rear of internal junction box. Insert snap-in conduit connector in 7/8" blank knockout, squeeze tabs on side of connector, push into knockout and release tabs to lock connector in place.

Step f. Inside internal junction box, locate wires with mating aquastat plug connector labeled "Aquastat" (refer to Figure 6 for details of harness located inside internal junction box). Align mating halves of socket connector from aquastat control with harness plug connector. Push connectors together until snap on connector is locked in place.

2. If required on this water boiler application, install low water cut-off (LWCO) Kit, optional equipment - Burnham P/N 100106-01, refer to Figure 7. Also refer to instructions provided with LWCO Kit.

If not required, proceed to Paragraph 3.

Step a. Apply sealant to probe threads and install in 3/4" NPT tapping on right side of manifold as shown. Tighten so that the mounting screws are horizontally aligned and joint is water tight.

Step b. Remove wing nut from the probe terminal. Loosen screw and open cover on control box.

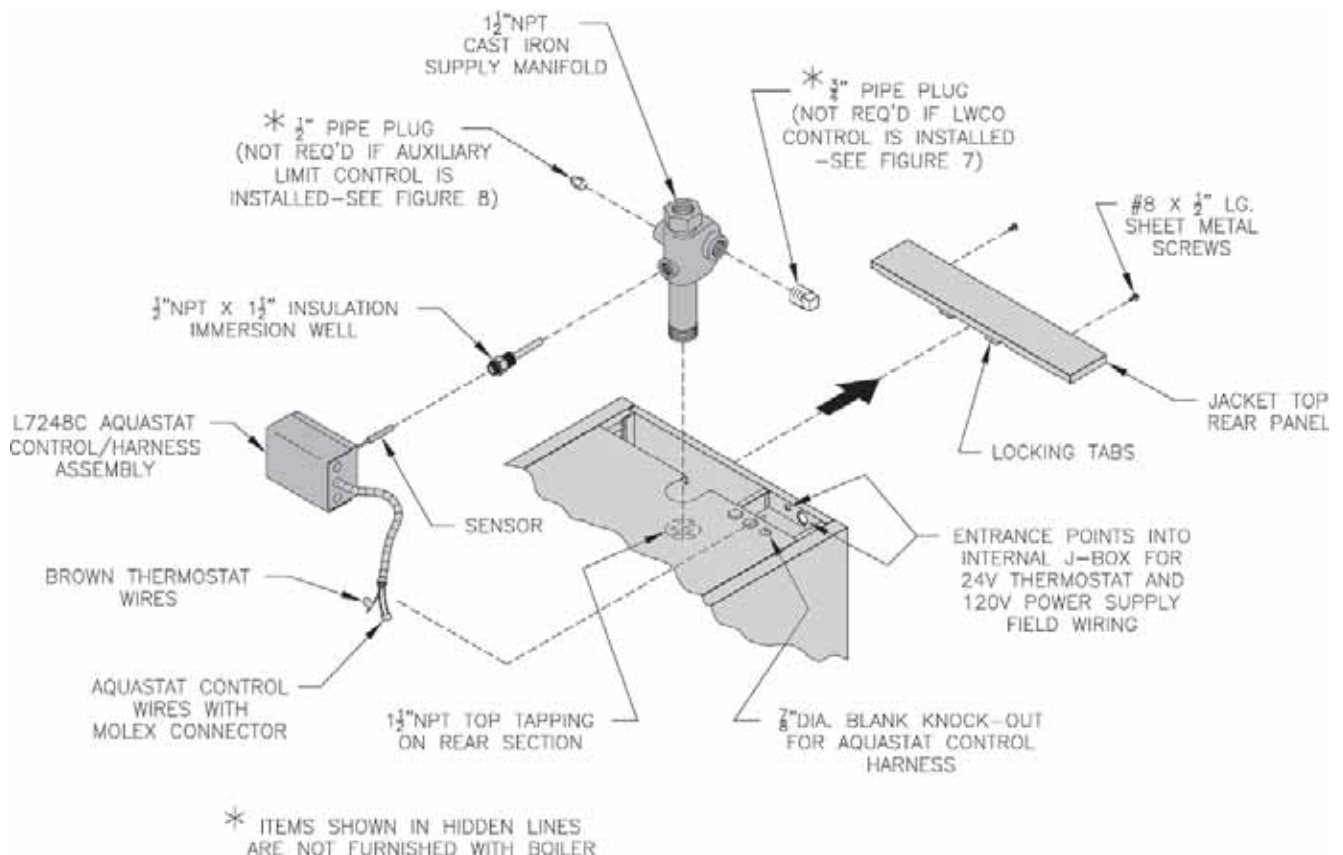

Figure 5: Supply Manifold and Aquastat Control Assembly Details

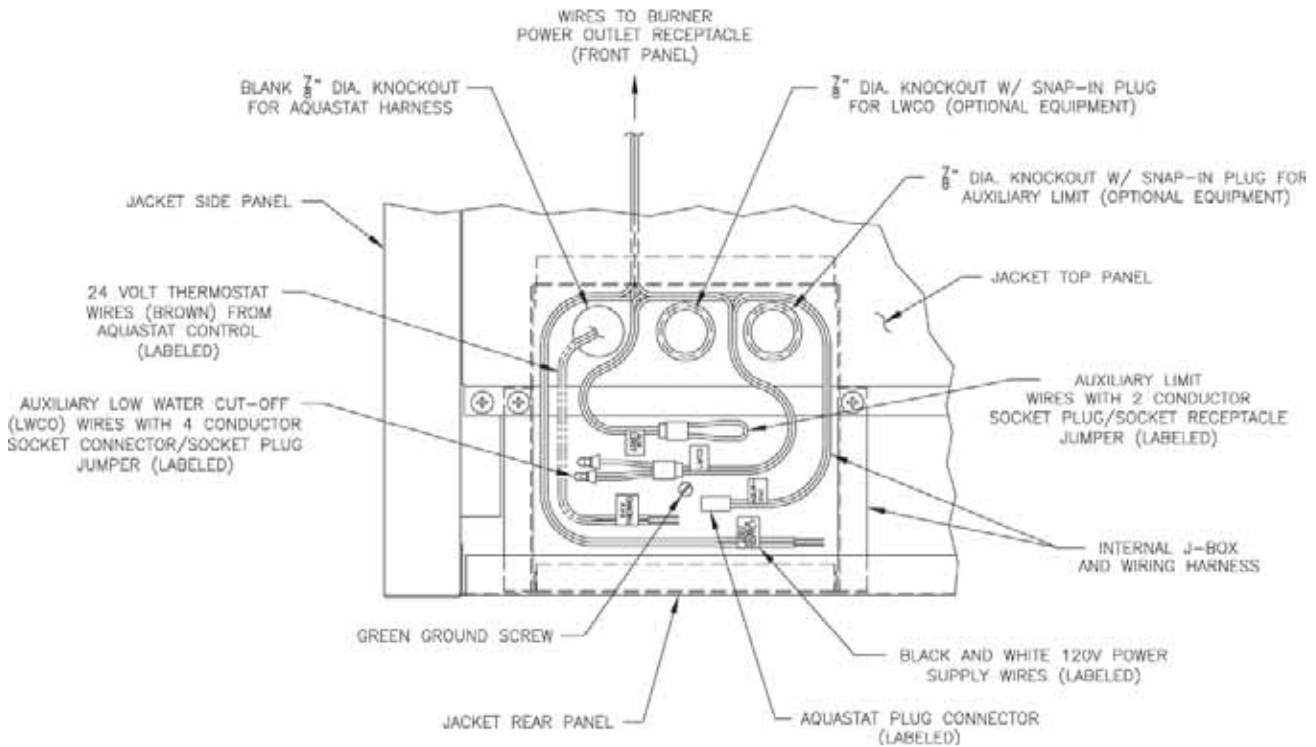

Figure 6: Internal Junction Box and Wiring Harness Details

Mount the control box on the probe by aligning the keyhole slots with the probe mounting screws. Replace the wing nut. Secure the control box by tightening wing nut and two (2) mounting screws.

Step c. Remove snap-in plug from 7/8" dia. center knockout, adjacent to aquastat control harness.

Step d. Insert three (3) wires with Molex connector located on opposite end of LWCO harness through 7/8" dia. knockout. Fish wires with Molex connector to rear of internal junction box. Insert snap-in conduit connector into 7/8" dia. knockout, squeeze tabs on side of connector, push into knockout and release tabs to lock connector in place.

Step e. Inside internal junction box, locate wires with mating LWCO socket connector labeled "LWCO" (refer to Figure 6 for details of harness located inside internal junction box). Remove the factory installed socket plug jumper from LWCO harness socket connector and discard. Align mating halves of plug connector from LWCO control with harness socket connector. Push connectors together until snap on side of connector is locked in place.

3. If required on this water boiler application, install Auxiliary Dual Limit Control Kit, optional equipment - Burnham P/N 100107-01, refer to Figure 8. Also refer to instructions provided with Auxiliary Dual Limit Control Kit.

If not required, proceed to Paragraph 4.

Step a. Locate 1/2" NPT x 1-1/2" immersion well. Apply thread sealant to 1/2" NPT male threads. Thread well into 1/2" NPT boss on left side of supply manifold. Using hex head, tighten well until water tight.

Step b. Locate L4080B Auxiliary Limit Control/Harness Assembly. Loosen mounting screw on side of case. Insert sensing bulb into immersion well. Mount control on immersion well and tighten screw to secure control in vertical position with harness extending toward rear as shown in Figure 8.

Step c. Remove snap-in plug from 7/8" dia. knockout closest to supply manifold. Remove locking ring from 90° conduit connector on end of control harness.

Step d. Insert two (2) wires with Molex connector located on end of auxiliary limit control harness through 7/8" dia. knockout. Fish wires with Molex connector to rear of internal junction box. Insert 90° conduit connector into 7/8" dia. knockout, secure to top panel with locking ring.

Step e. Inside internal junction box, locate wires with mating auxiliary limit socket connector labeled "Aux. Limit" (refer to Figure 6 for details of harness located inside internal junction box). Remove the factory installed socket plug jumper from harness socket connector and discard. Align mating halves of plug connector

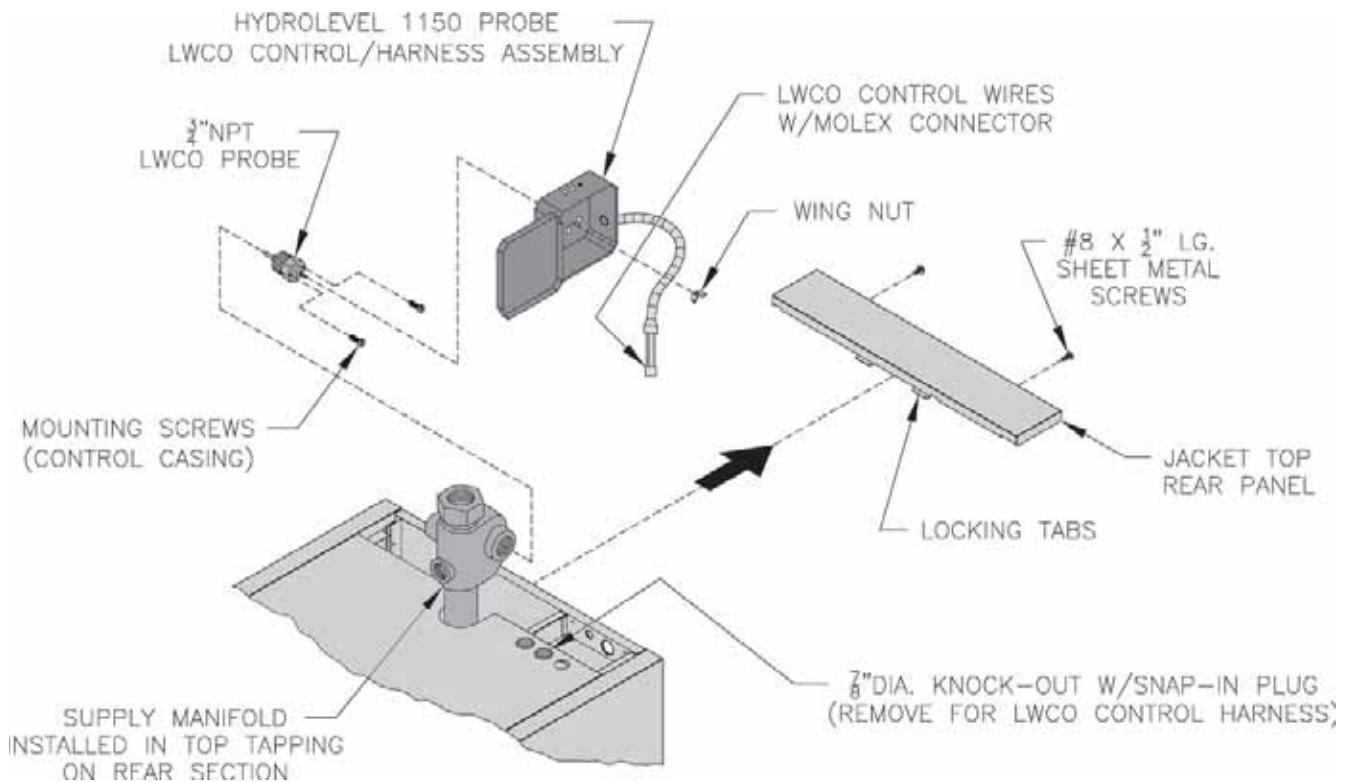

Figure 7: Optional Equipment - Low Water Cut-Off (LWCO) Control Assembly Details

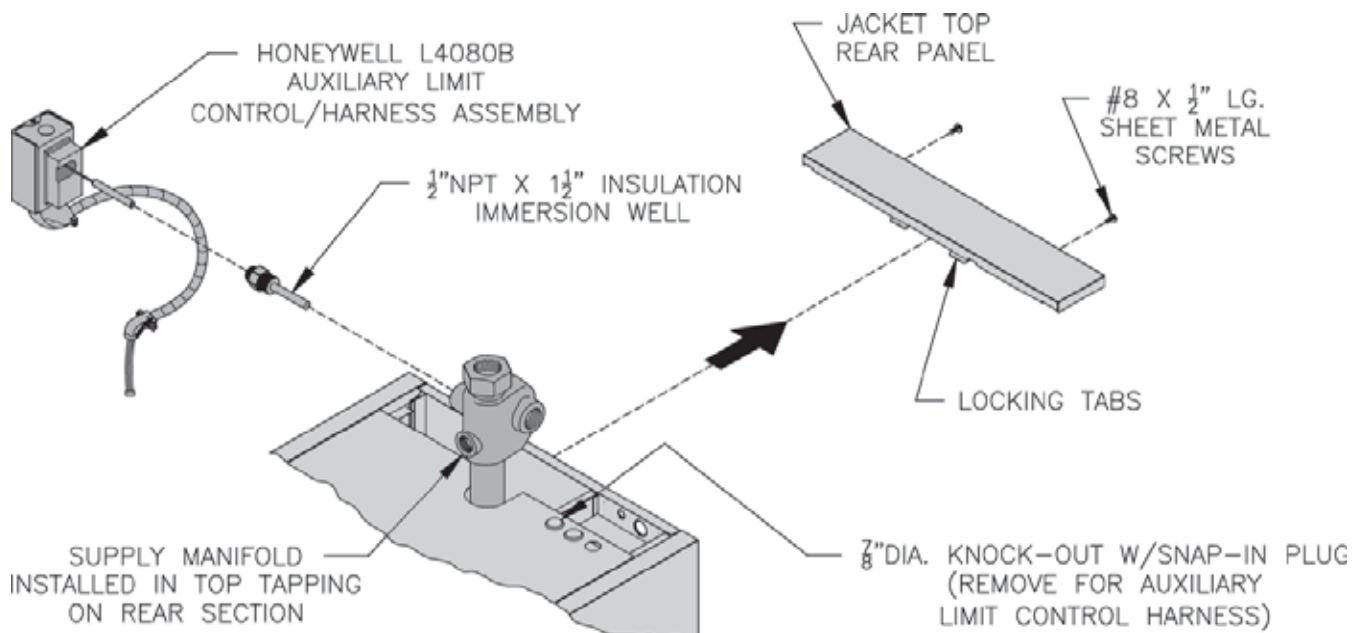

Figure 8: Optional Equipment - Auxiliary Limit Control Assembly Details

from auxiliary limit control with harness socket connector. Push connectors together until snap, on side of connector, is locked in place.

4. Install return manifold and relief valve, refer to Figure 9.

Step a. Locate the cast iron return manifold with injector nipple (installed). Apply thread sealant to 2" NPT male threads. Insert injector nipple

into 2" NPT upper rear tapping on rear section, engage 2" NPT male threads on end of manifold and hand tighten.

Note: Based on system return piping and access to service boiler, see Figure 1 and Figures 18A and 18B, predetermine if manifold orientation is to be positioned for vertical, horizontal left or horizontal right side return piping as shown in Figure 9.

Place a wrench on the hex nut portion and tighten manifold until the return pipe orientation is correct for your installation and the joint is water tight.

Step b. Install relief valve using 3/4" NPT tapping on side of return manifold. Relief valve must be installed in vertical position. If orientation of return manifold is for:

- 1-1/2" NPT vertical return piping - Install 3/4" NPT x 90° street ell (not furnished) into either the left or right side tapping on return manifold. Install relief valve vertically into street ell. Install 3/4" pipe plug (not furnished) in tapping on opposite side (see Figure 9).
- 1-1/2" NPT horizontal left or right side return piping - Install relief valve vertically in 3/4" NPT tapping located on top of return manifold. Install 3/4" pipe plug (not furnished) in bottom tapping as shown (see Figure 9).

Step c. Pipe discharge of relief valve as shown in Figures 18A and 18B. Installation of the relief valve must be consistent with ANSI/ASME Boiler and Pressure Vessel Code, Section IV.

WARNING

Safety valve discharge piping must be piped near floor to eliminate potential of severe burns. Do not pipe in any area where freezing could occur. Do not install any shut-off valves, plugs or caps.

5. Install drain valve and indirect water heater return piping, see Figure 10.

Step a. Apply pipe sealant to both ends of 1-1/4" NPT x 5" lg. nipple. Thread nipple into 1-1/4" NPT lower rear tapping on rear section.

Step b. Thread 1-1/4" x 1-1/4" x 3/4" NPT tee on opposite end of 5" lg. nipple installed in Step a.

NOTE: Based on access for servicing and location of sewer or floor drain, when tightening

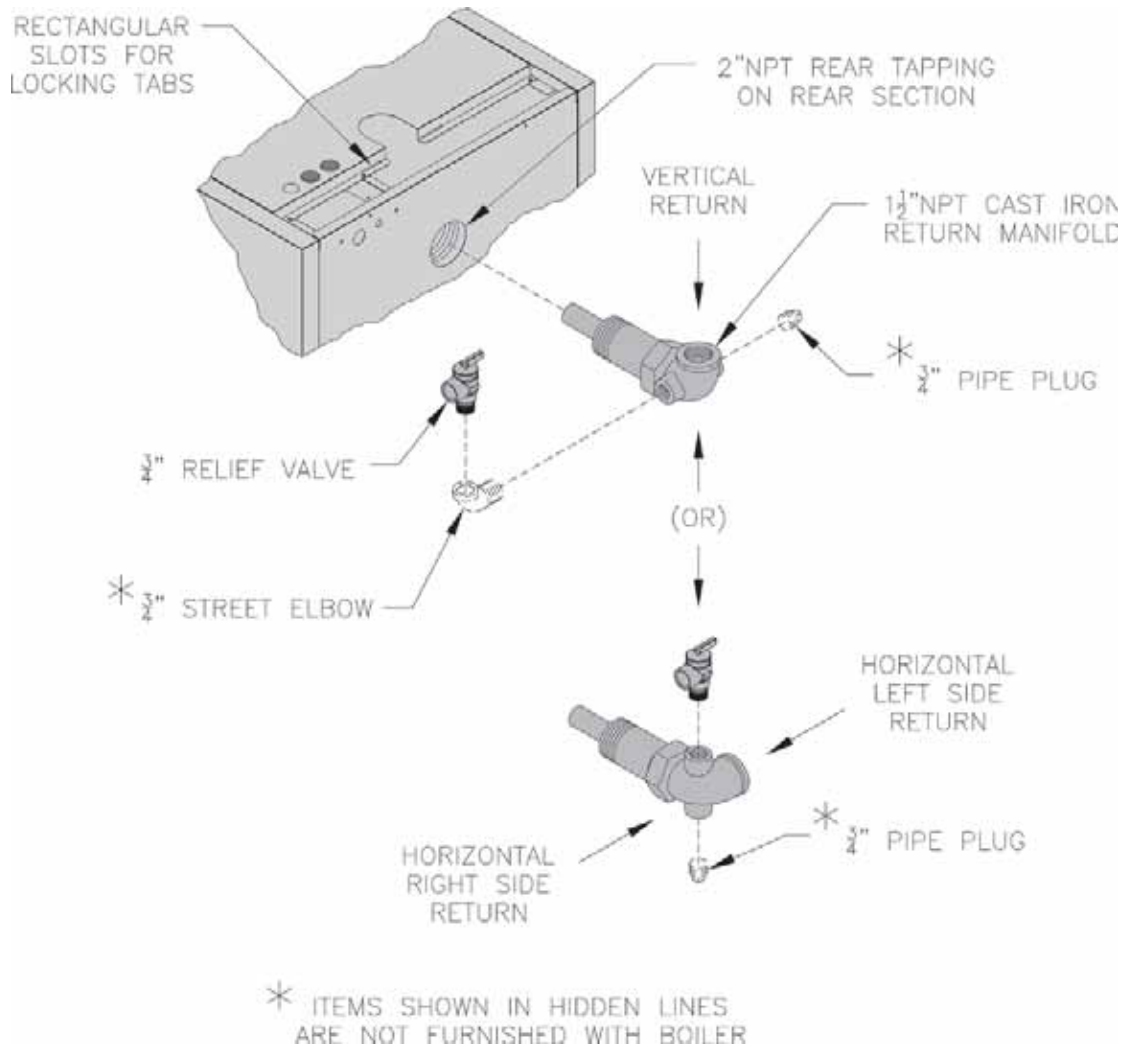

Figure 9: Return Manifold and Relief Valve Assembly Details

these fittings, determine if drain valve is to be located on the left or right side.

Tighten nipple and tee into 1-1/4" NPT lower rear tapping on rear section until joints are water tight for desired position.

Step c. Apply sealant to 3/4" NPT thread on drain valve. Thread into 3/4" NPT tapping on side outlet of tee. Use hex nut portion to tighten valve until water tight.

Step d. If an Alliance SL™ water heater is connected to system, do not install 1-1/4" NPT pipe plug. Connect piping as shown in Figures 18A, 18B, 20A and 20B, as applicable. Also refer to Alliance SL™ instructions for additional information.

6. Connecting field wiring, refer to Figures 5, 6 and 34A or 34B.

Step a. 120 volt power supply field wiring will enter internal junction box through 7/8" dia. knockout in jacket rear panel, see Figure 5.

Step b. Locate the black and white harness wires labeled "120V Power Supply" inside internal junction box, see Figure 6. Using wire nuts, connect the 120 volt power supply field wires to the harness wires. Connect the field ground wire to the green grounding screw located in bottom of internal junction, refer to Figures 6 and 34A or 34B.

Step c. 24V thermostat field wiring will enter internal junction box through 5/16" snap bushing located on rear panel adjacent to 7/8" dia. knockout for power supply.

Step d. Locate the two (2) brown wires labeled "24V Thermostat" inside the internal junction box, see Figure 6 (these wires originate from "T-T" terminals in aquastat control and feed into J-box through harness). Using wire nuts, connect 24 volt field thermostat wires to brown wires in J-box.

Step e. Locate jacket top rear panel that was removed earlier to gain access to internal junction box. Position panel between side panels, hold on a slight angle, engage tabs on front flange of **top rear** panel with rectangle slots on rear flange of **top** panel, refer to Figures 5 and 9.

NOTE: It may be necessary to lift up slightly on **top** panel near slotted opening at supply manifold to align tabs with rectangular slots on flanges.

Lower rear flange of jacket **top rear** panel down over **rear** panel. Align holes and secure with two (2) #8 x 1/2" lg. sheet metal screws.

7. Installing stainless steel flueway baffles. Baffle requirements differ from model to model, see Table 3.

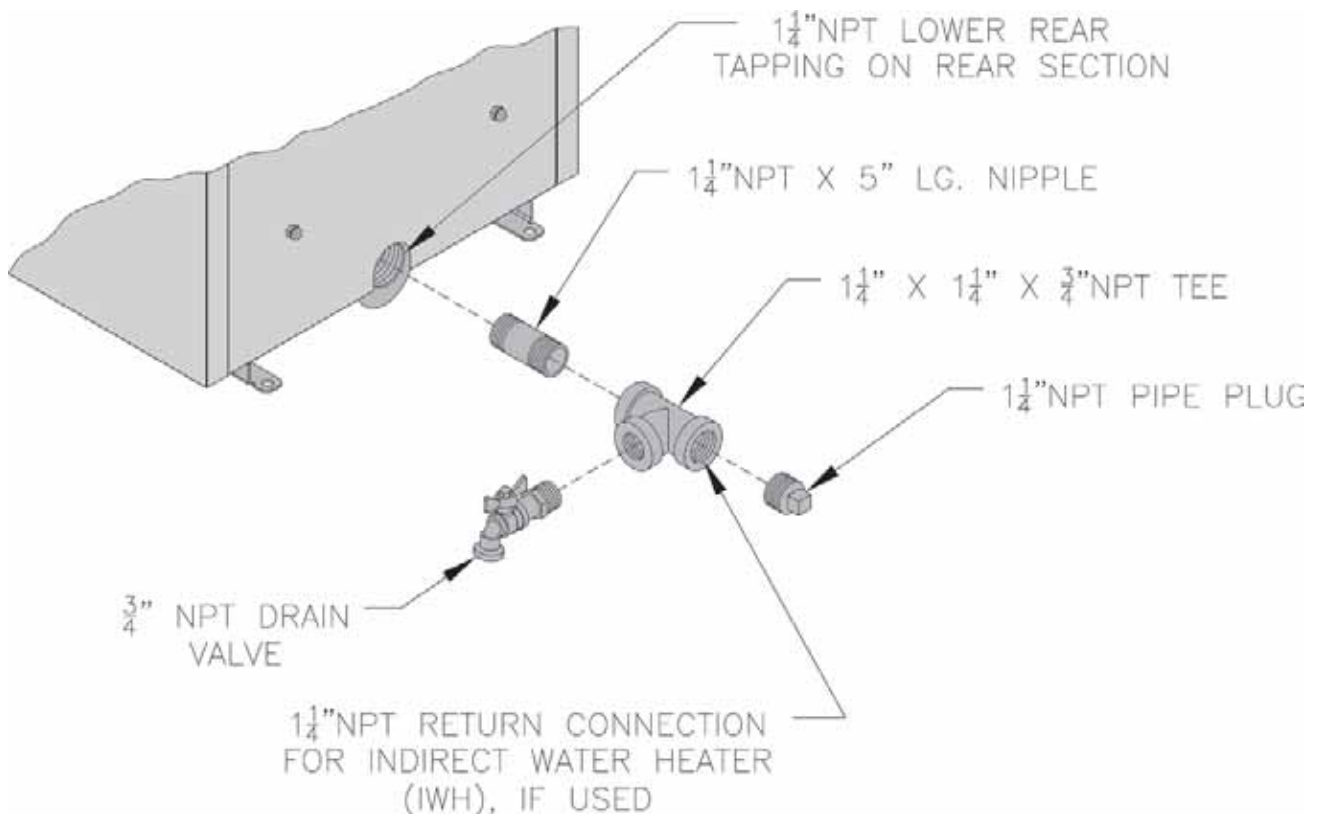

Figure 10: Piping Arrangement for Drain Valve and Indirect Water Heating Return

NOTE: Read caution statement **before** proceeding.

CAUTION

These baffles will generate higher efficiencies and lower stack temperatures. Under certain conditions, a lower gross stack temperature entering the chimney has the potential to be cooled below the dew point and create condensate on interior surfaces. Flue gas condensate is corrosive, which requires special consideration and must be addressed immediately.

DO NOT install baffles until you have read Section VI, "Venting" completely.

TABLE 3: BAFFLE USAGE

Boiler Model	Baffle Usage	
	2 nd Pass	3 rd Pass
MPO84	None	[2] P/N 100081-01
MPO115	[2] P/N 102066-01	
MPO147	[2] P/N 100042-01	None
MPO189		
MPO231		

Step a. Install stainless steel baffles provided in miscellaneous parts carton as follows, refer to Table 3 and Figure 11:

- Model MPO84 - To install flueway baffle in 3rd pass on left side of boiler, hold baffle with word "Left" readable at the top. Slide baffle in flueway until position tab touches fins on left side of 3rd pass flueway. To install flueway baffle in 3rd pass flueway on right side of boiler, hold baffle with word "Right" readable at the top. Slide baffle in flueway until position tab touches fins on right side of 3rd pass flueway.
- Model MPO115 - To install flueway baffle in 3rd pass on left side of boiler, hold baffle with word "Left" readable at the top. Slide baffle in flueway until position tab touches fins on left side of 3rd pass flueway. To install flueway baffle in 3rd pass flueway on right side of boiler, hold baffle with word "Right" readable at the top. Slide baffle in flueway until position tab touches fins on right side of 3rd pass flueway. To install flueway baffle in 2nd pass on left side of boiler, hold baffle with word "Left" readable at the top. Slide baffle in flueway until position tab touches fins on left side of 3rd pass flueway. To install flueway baffle in 2nd pass flueway on right side of boiler, hold baffle with word "Right" readable at the top. Slide baffle in flueway until position tab touches fins on right side of 3rd pass flueway.

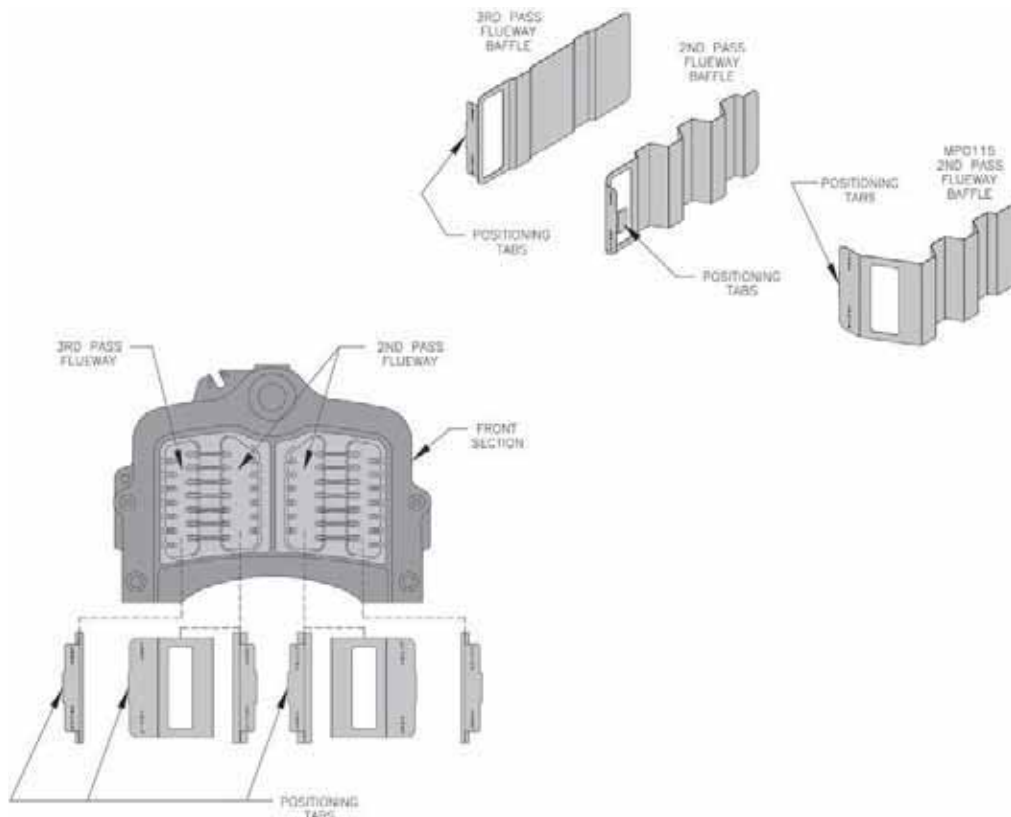

Figure 11: Baffle Orientation in Flueways

- Models MPO147, MPO189 and MPO231
- To install flueway baffle in 2nd pass flueway on left side of boiler, hold baffle with word "Left" readable at the top. Slide baffle in flueway until position tab touches fins on right side of 2nd pass flueway. To install flueway baffle in 2nd pass flueway on right side of boiler, hold baffle with word "Right" readable at the top. Slide baffle in flueway until position tab touches fins on left side of 2nd pass flueway.

NOTE: 2nd and 3rd pass flueway baffle are not interchangeable.

- Close the burner swing door and securely seal the door to the boiler front section by reinstalling the hardware and securing the door using procedure previously outlined in Paragraph D of this section.

NOTICE

When securing burner swing door make sure door is drawn-in equally on both sides.

- Install Beckett oil burner. (See Figure 12)

Step a. Open burner carton and remove contents.

Step b. Place oil burner gasket on burner and align holes.

CAUTION

Do not install burner without gasket.

Step c. Remove three (3) 5/16-18 x 3/4 lg. cap screw from burner swing door used for mounting burner.

Step d. Thread (1) 5/16-18 x 3/4 lg. cap screw, approximately three (3) full turns, into tapping located at 12:00 o'clock on burner swing door.

Step e. Insert oil burner into the opening of burner swing door. Align and engage keyhole slot in burner flange over head of protruding cap screw installed in previous Step. Rotate burner to the right to lock flange behind head of cap screw.

Step f. Align holes and install two (2) remaining cap screws. Level burner and fully tighten all three (3) screws.

Step g. Plug burner power cord into power outlet receptacle located in lower right corner of front panel.

Step h. Check oil nozzle in burner for size, angle and spray type; inspect electrode settings and head/air plate setting. Refer to Tables 10, 13A, 13B and Section X

- Install Riello Oil Burner. (See Figure 12A)

Follow instructions in Paragraph 9, *Steps a* thru *g*.

Step h. Verify oil nozzle installed in burner, inspect electrodes and head setting.

- Installation/Removal of Drawer assembly, refer to Figure 41A.

i. Removal:

- Disconnect oil delivery tube nut from pump.
- Loosen SCREW (3), and then unplug PRIMARY CONTROL (1) by carefully pulling it back and then up.
- Remove the AIR TUBE COVER PLATE (5) by loosening the retaining SCREW (4) (Two SCREWS-Model F5).
- Loosen SCREW (2), and then slide the complete drawer assembly out of the combustion head as shown.

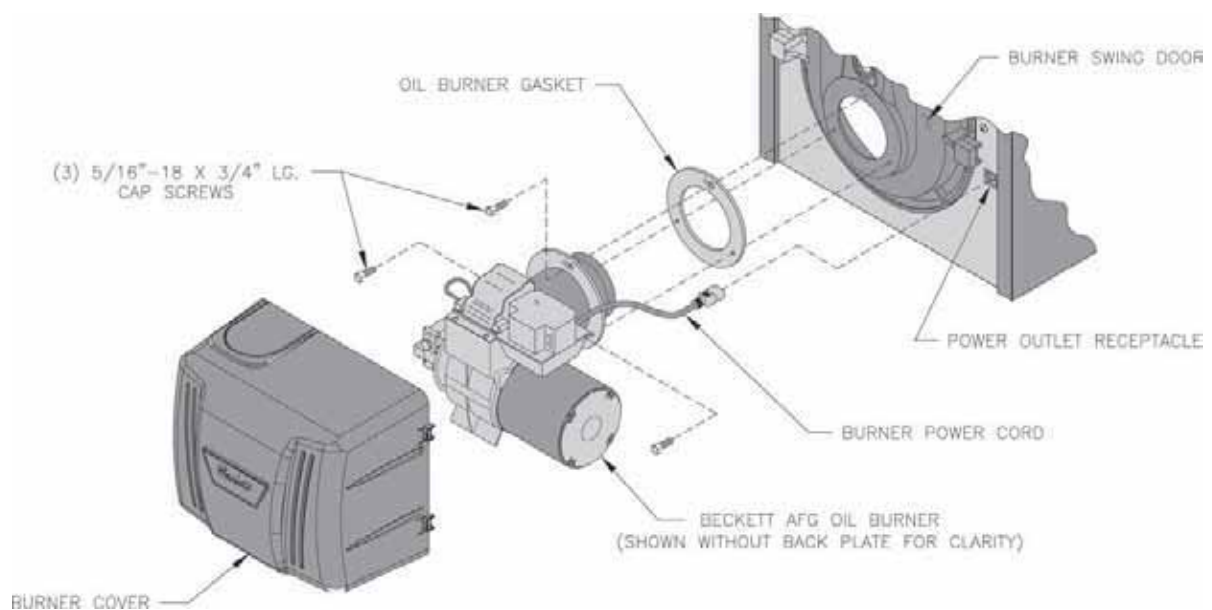

Figure 12: Beckett Oil Burner Installation

- ii. Installation:
 - To insert drawer assembly, reverse the procedure in Item *i* above.
- b. Check factory installed oil nozzle for size and type. Refer to Table 13 for details.

If nozzle needs replacement, follow steps below. Also refer to Figure 41B.

 - i. Remove the nozzle adapter (2) from the drawer assembly by loosening the screw (1).
 - ii. Remove existing nozzle from nozzle adapter.
 - iii. Insert the proper nozzle into nozzle adapter and tighten securely. (Do not over tighten).
 - iv. Replace adapter, with nozzle installed, into drawer assembly and secure with screw (1).
- c. Inspect and measure burner electrodes. Refer to Figure 41D for the proper electrode settings.
- d. Re-install Drawer Assembly into Combustion Head per **Step h** c above.
- e. Insertion Depth, verify the distance between the tip of the end cone is equal to the distance specified in Table 13 of this manual.
- f. Turbulator Setting, refer to Figure 41C.
 - i. Confirm the turbulator setting is correct for input oil nozzle installed in the burner, readjust, if needed, to index mark specified in Table 13 of this manual.
 - ii. Loosen nut (1) and turn screw (2) until the index marker (3) is aligned with the correct index number in the Burner Setup Chart (Table 13).

- iii. Retighten the retaining nut (1).

MODEL F5 (3 thru 5 Section): Same as above, except, scale indicators are 0 and 4.

- i. Pump Connections and Port Identification, refer to Figure 41E.

This burner is shipped with the oil pump set to operate on a **single** line system. To operate on a **two-line** system the bypass plug must be installed.

WARNING: Do not operate a **single** line system with the by-pass plug installed. Operating a single line system with the by-pass plug installed will result in damage to the pump shaft seal.

NOTE: Pump pressure was factory pre-set but must be checked at time of burner start-up. A pressure gauge is attached to the PRESSURE/ BLEEDER PORT (7) for pressure readings. Two PIPE CONNECTORS (4) are supplied with the burner for connection to either a single or two-line system. Also supplied are tow ADAPTORS (3), two female 1/3" NPT to adapt oil lines to burner pipe connectors. All pump port threads are **British Parallel Thread** design. Direct connection of NPT threads to the pump will **damage** the pump body.

Riello manometers and vacuum gauges do not require any adapters, and can be safely connected to the pump ports. An NPT x metric adapter **must** be used when connecting other gauge models.

- g. Replace Burner Cover and Tighten Burner Cover Screws.

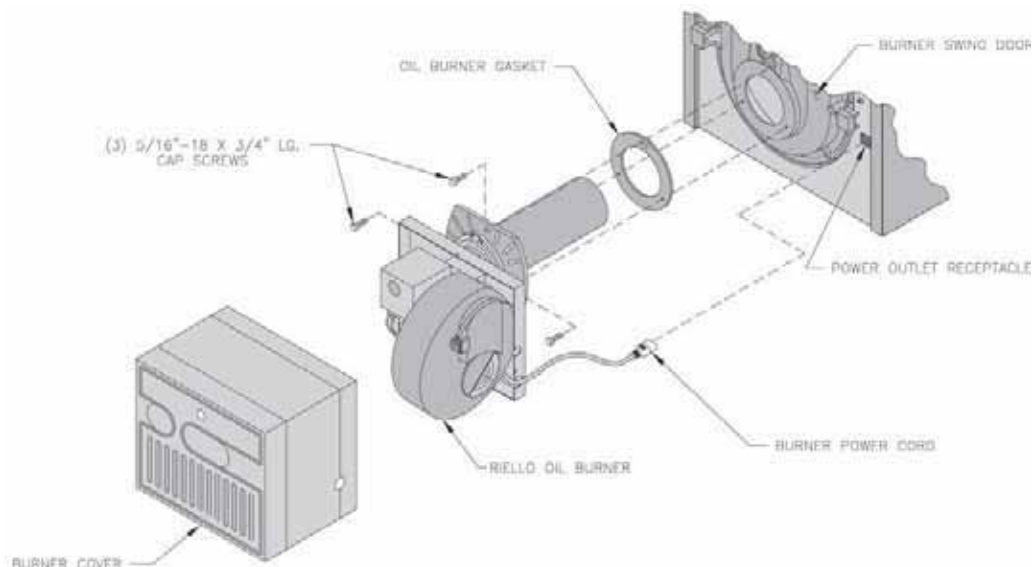

Figure 12A: Riello Oil Burner Installation

SECTION III: UNIT-PAK BOILER ASSEMBLY - TRIM & CONTROLS

MPO® Unit-Pak Boiler Assembly Shipment

Content Check List (see Figure 13)

1. ___ **Cast Iron Section/Burner Swing Door/Smoke Box Assembly Mounted on Shipping Skid:**

- ___ MPO2 – Part # 100032-01 / 100045-01 / 100021-01
- ___ MPO3 – Part # 100032-02 / 100045-01 / 100021-01
- ___ MPO4 – Part # 100032-03 / 100045-01 / 100021-01
- ___ MPO5 – Part # 100032-04 / 100045-02 / 100021-01

2. ___ **Jacket Carton**

- ___ MPO2 – Part # 102135-02
- ___ MPO3 – Part # 102135-03
- ___ MPO4 – Part # 102135-04
- ___ MPO5 – Part # 102135-05

3. ___ **Part Carton**

- ___ MPO84 – Part # 102136-01
- ___ MPO115 – Part # 102136-02
- ___ MPO147/189 – Part # 102136-03
- ___ MPO231 – Part # 102136-04

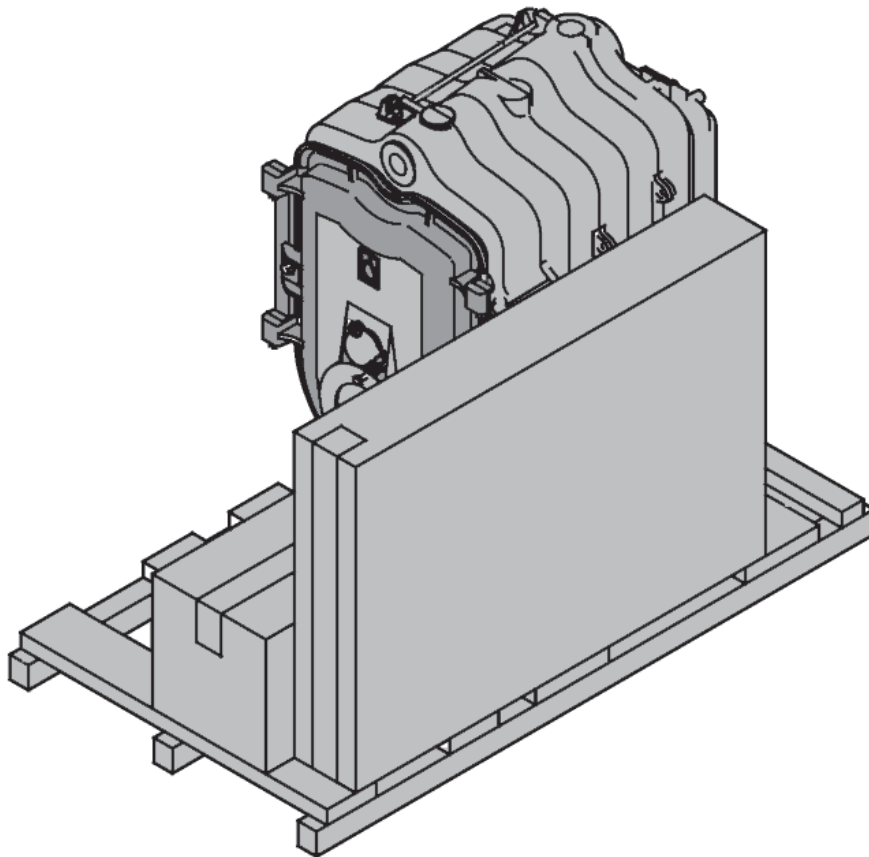

Figure 13: MPO® Unit-Pak Boiler Shipment Contents (outside container removed)

**A. REMOVAL OF CAST IRON SECTION/
BURNER SWING DOOR / SMOKE BOX
ASSEMBLY FROM SKID.**

WARNING

The Cast Iron Section/Burner Swing Door/Smoke Box Assembly has a substantial weight. Insure the travel path to permanent location, as well as mounting surface at boiler permanent location, are structurally sound and rated to handle the boiler weight and water content (refer to Table 1A). Otherwise, a potentially hazardous situation could result in death, serious injury and substantial property damage.

1. Move crated Cast Iron Section/Burner Swing Door/Smoke Box Assembly and part cartons on the shipping skid as close to final permanent location as possible.
2. Remove all fasteners at crate skid. Lift outside container. Examine the skid contents for damage due to shipping and handling.
3. Remove Jacket Carton and Part Carton from skid and set aside.
4. READ AND UNDERSTAND ALL INSTRUCTIONS BEFORE ATTEMPTING UNIT HANDLING AND INSTALLATION.
5. The Cast Iron Section/Burner Swing Door/Smoke Box Assembly is secured to shipping skid with four lag screws. Remove the screws and discard.
6. For manual Cast Iron Section/Burner Swing Door/Smoke Box Assembly removal prepare one piece of 4" x 4" x 16" lg. (or two pieces of 2" x 4" x 16" lg.) and two pieces of 1" Sch. 40 black pipe to be used as handles.
7. Place wooden block(s) 12" from rear of skid as shown. See Figure 14 "Boiler Removal from Skid".
8. Insert 1" Sch. 40 black pipe handles thru leg holes in front and rear section legs. Center rear pipe ends on wooden block(s). See Figure 14.
9. For best leverage, the pipe handles should extend 48" minimum beyond front section face.
10. Using the pipe handles, lift the Cast Iron Section/Burner Swing Door/Smoke Box Assembly until adjustable legs are elevated above the skid deck boards.
11. Remove the skid from underneath the Cast Iron Section/Burner Swing Door/Smoke Box Assembly.
12. Lower pipe handles until front adjustable legs touch the floor. Place wood blocks under front legs, if required, before lowering, to provide hand clearance.
13. To lower rear of the Cast Iron Section/Burner Swing Door/Smoke Box Assembly tilt unit slightly forward by pushing on smokebox, or, lift pipes protruding

thru rear legs, until wooden block(s) can be removed (see Figure 14). Slowly allow the weight of boiler to tilt backward until rear legs rest on floor.

14. If wood blocks were placed under front legs, lift pipe handles; remove the blocks and lower front legs to floor. Remove pipe handles.
15. Move Cast Iron Section/Burner Swing Door/Smoke Box Assembly to permanent position by sliding or walking.

CAUTION

Do not drop boiler when removing from skid and moving to permanent position.

**B. PROCEDURE TO OPEN, CLOSE AND
SECURE BURNER SWING DOOR.**

Throughout this manual you will be instructed to open and close Burner Swing Door for various reasons. There is a proper and improper method of closing and securing the door opened for front jacket panel installation, inspection, cleaning or field service. Refer to Figures 15 thru 17 and paragraphs C "Jacket Front Panel Installation", and, E "Closing/Securing Burner Swing Door" for details.

C. JACKET FRONT PANEL INSTALLATION.

In order to install front jacket panel Burner Swing Door and door mounting bracket need to be removed. As shipped, the door would open to the left side.

1. To open/remove Burner Swing Door (mounted on Cast Iron Section/Burner Swing Door/Smoke Box Assembly) and door mounting bracket for front jacket panel installation:
 - a. Loosen but not remove door left side latching hardware (3/8"-16 x 1-3/4" tap bolt).
 - b. Loosen and remove door right side latching hardware (3/8"-16 x 1-3/4" tap bolt and 5/16" washer) and set aside.
 - c. Remove door left side latching hardware (3/8"-16 x 1-3/4" tap bolt and 5/16" washer) and set aside.
 - d. Lift the door off mounting bracket and set aside.
 - e. Remove two 5/16"-18 - 3/4" hex head cap screws securing door mounting bracket to front section and set aside.
 - f. Remove door mounting bracket and set aside.
 - g. Note/mark cap screw bosses on front section left side; locate/mark similar two bosses directly opposite on front section right side. These four front section bosses are front jacket panel and door mounting bracket attachment points.
2. Open Jacket Carton and locate jacket front panel (has factory attached 1" fiberglass insulation). See also "Repair Parts" Section, "Jacket Assembly" illustration for part identification.

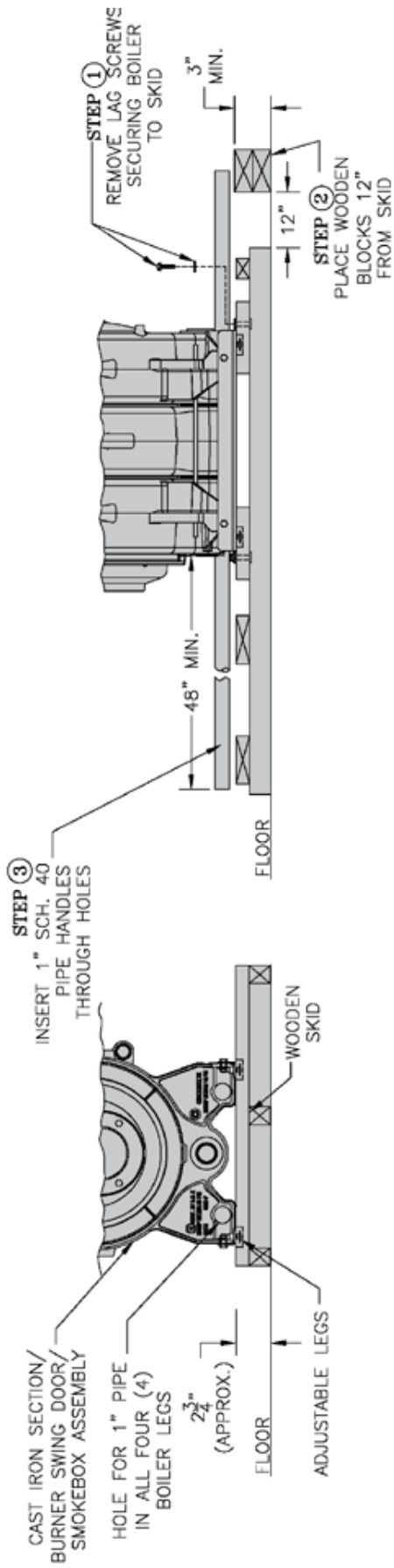

PARTIAL FRONT VIEW

PARTIAL SIDE VIEW NO. 1

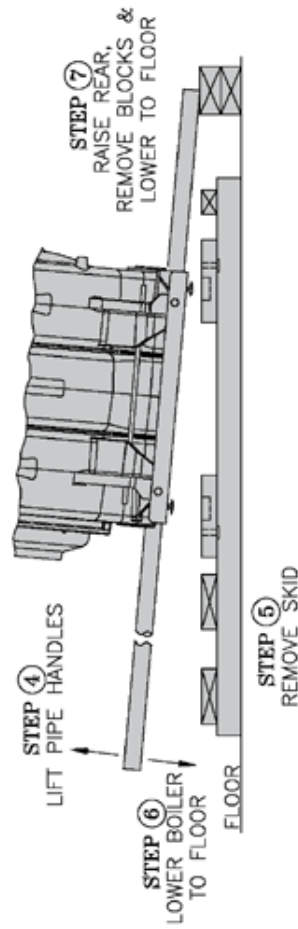

PARTIAL SIDE VIEW NO. 2

Figure 14: Boiler Removal from Skid

3. Locate Hardware Bag, remove two 5/16"-18 x 1/2" Phillips pan head machine screws.
4. Place front jacket panel over front section attachment bosses and align jacket holes with front section boss holes.
5. Firstly, install two 5/16"-18 x 1/2" Phillips pan head machine screws hand tight to secure front jacket panel right side to casting
6. Secondly, insert 5/16"-18 - 3/4" hex head cap screw thru door mounting bracket upper hole and upper hole on left side of front jacket panel simultaneously, and, fasten the bracket and panel to casting hand tight.
7. Thirdly, insert 5/16"-18 - 3/4" hex head cap screw thru door mounting bracket lower hole and lower hole on left side of front jacket panel simultaneously, and, fasten the bracket and panel to casting hand tight.
8. Finally, tighten both sets of hardware to secure the bracket and front jacket panel.
9. Inspect fiberglass rope located on the swing door. The rope must be evenly distributed around the perimeter of the door groove and cannot bunch or overhang. Repair or replace, if the rope is damaged, or, there is a gap between the rope ends.
10. Inspect burner swing door insulation for damage and proper type.

By design, for all models, cast bars on front section between the combustion chamber, and, between the left and right side 2nd and 3rd pass flueways should make an impression in door insulation to seal the chambers.

By design, door insulation on model MPO231 **will have** two by-pass pockets cast into the insulation centered on the bar between the combustion chamber and 3rd pass flueways. By design, door insulation on models MPO84, MPO115, MPO147 and MPO189 **will not have** any by-pass pockets. If insulation is damaged, or, improper type regarding the pockets, it must be replaced.

11. Upon inspection completion, lift door and place integral cast hinge pins into door mounting bracket slotted holes. Do not close and secure door at this time, proceed to installing stainless steel flueway baffles.
12. Locate/remove four #8 x 1/2" shoulder sheet metal screws from Hardware Bag, then, install them into front panel flange holes.

D. FLUEWAY BAFFLE INSTALLATION. Refer to Section II, Paragraph 7.

E. CLOSING / SECURING BURNER SWING DOOR.

1. To close and secure Burner Swing Door:
 - a. From fully open position, rotate the door to the closed position.

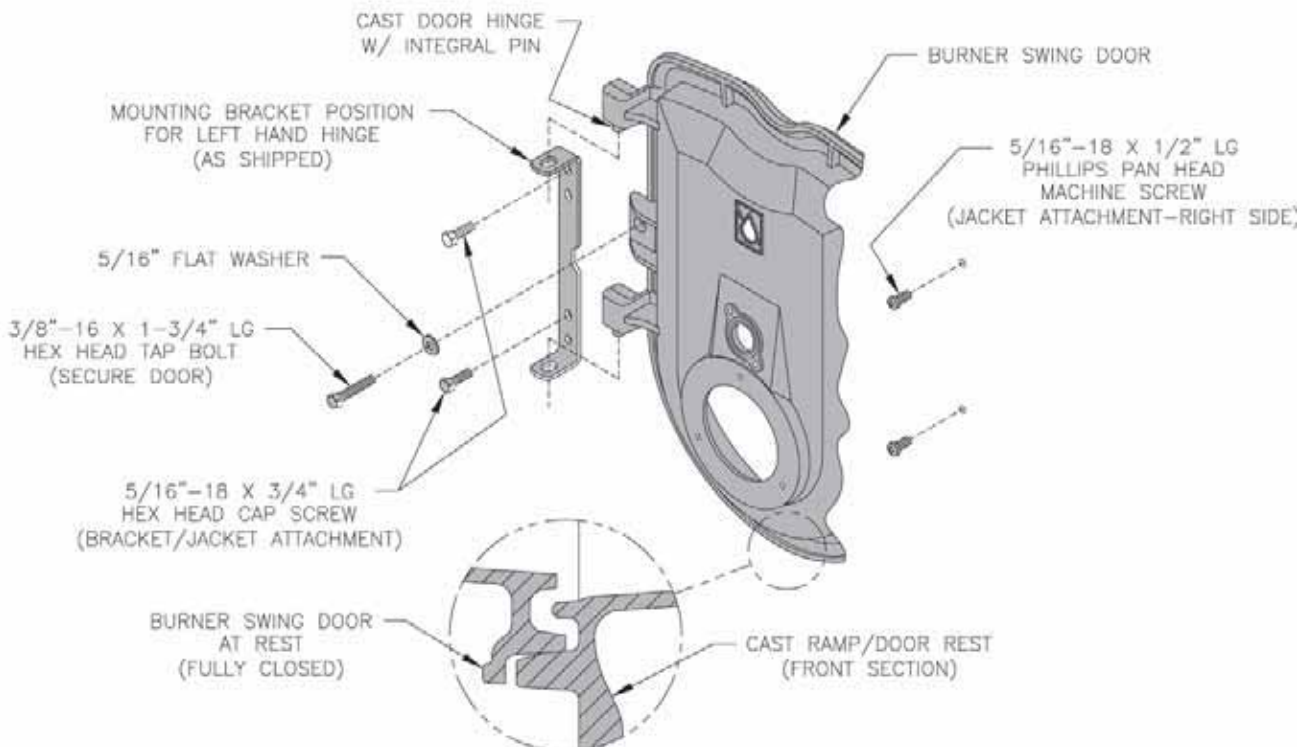

Figure 15: Partial Front View - Burner Swing Door Mounted to Boiler - Fully Closed and Secured

- b. Lift door upward into the build-in cast ramp/door rest (protruding from the bottom of the front section casting – see Figure 15).
- c. Use one hand to apply pressure directly to the door to hold it in closed position while re-installing earlier removed door-latching hardware (3/8"-16 x 1-3/4" tap bolt and 5/16" washer). Prior to re-installation, apply a drop of supplied Anti-seize (pouch provided in Part Carton) to both tap bolts for rust protection and to facilitate easy removal, if burner door is to be open for inspection and service. **ALWAYS INSTALL RIGHT SIDE LATCHING HARDWARE FIRST, THEN INSTALL EARLIER REMOVED LEFT SIDE HINGE HARDWARE (3/8"-16 X 1-3/4" TAP BOLT AND 5/16" WASHER) SECOND.**

Apply additional pressure while hand tightening the hardware as far as possible and then release the pressure.

NOTICE

When securing burner swing door make sure door is drawn-in equally on both sides.

- d. Use a hand or socket wrench to tighten door hardware. **ALWAYS START WITH RIGHT SIDE TAP BOLT FIRST.** Use an alternating tightening method from right side tap bolt to left side tap bolt to tighten door equally, until sealed, without applying excessive torque. **NEVER TIGHTEN LEFT SIDE TAP BOLT FIRST, OR, EITHER PIECE OF HARDWARE**

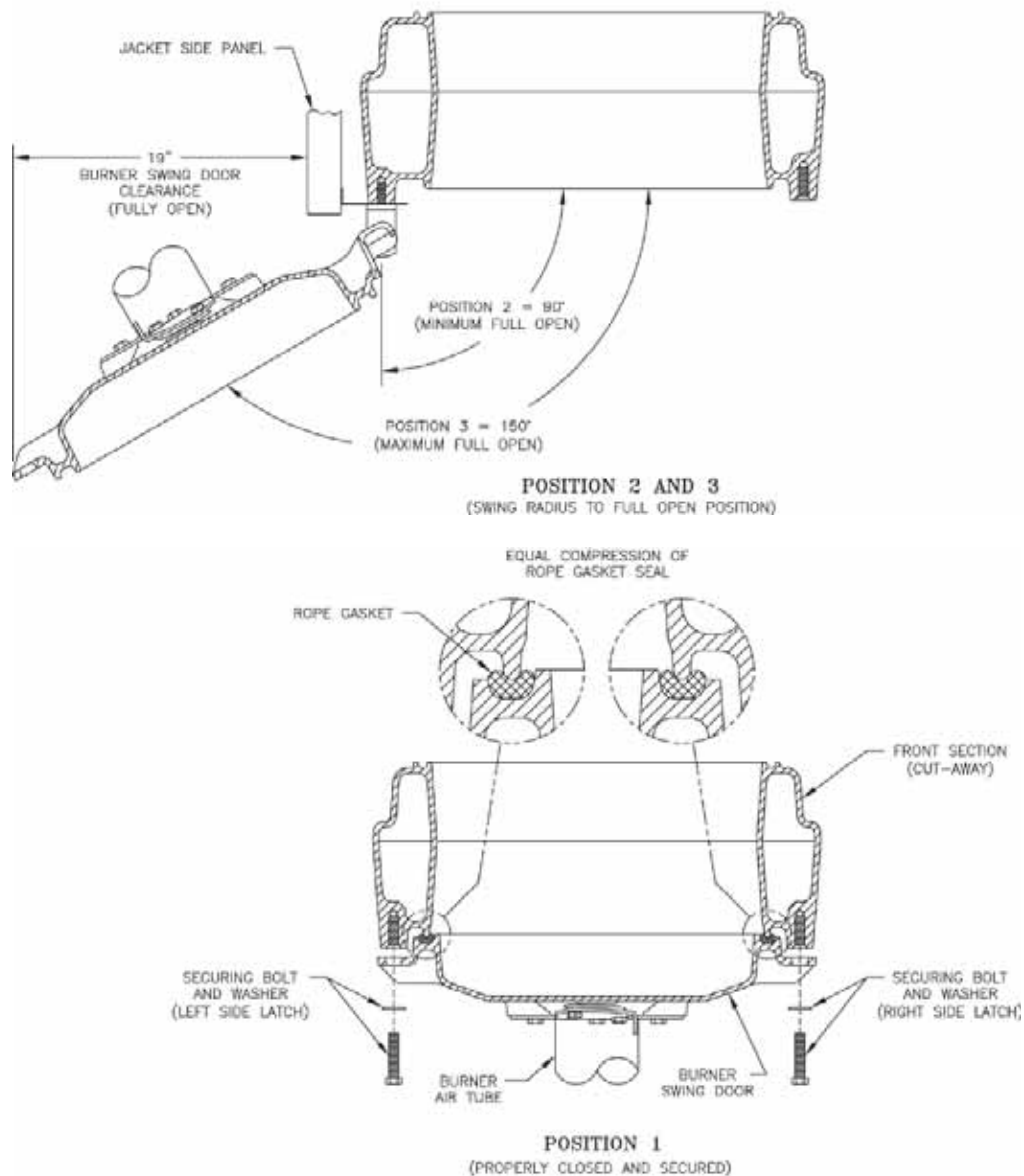

Figure 16: Top View - Burner Swing Door Mounted to Cast Iron Block Assembly (Jacket Removed for Clarity)

100% WITHOUT USING THE ALTERNATING METHOD DESCRIBED ABOVE. See Figure 16.

- e. Failure to follow the prescribed procedure could cause thread damage to casting and /or leak at the door seal. IF LEFT SIDE TAP BOLT IS TIGHTENED BEFORE RIGHT SIDE TAP BOLT, RIGHT SIDE OF THE DOOR CAN NOT BE DRAWN-IN TO PROVIDE AN AIR-TIGHT SEAL, as shown in Figure 17. Applying excessive torque will only cause thread damage.

F. JACKET REAR PANEL INSTALLATION.

1. Locate jacket rear panel (has factory attached 3" fiberglass insulation) inside Jacket Carton. See also "Repair Parts" Section, "Jacket Assembly" illustration for part identification.
2. Locate and remove from Hardware Bag rear panel mounting hardware – (2 pcs) 5/16"-18 x 3" lg. tap studs, (2 pcs) 5/16"-18 plated acorn nuts, (2 pcs) 5/8" x 2-9/32" round spacers and (2 pcs) 5/16"-18 x 1/2" Phillips pan head machine screws.
3. Locate rear panel two lower attachment bosses on rear section.
4. Thread both 5/16"-18 x 3" lg. tap studs, with short threaded end, into lower attachment bosses on rear section.
5. Install both 5/8" x 2-9/32" round spacers over tap studs.
6. Place rear jacket panel over rear section, so both tap studs clear thru lower panel holes, rear section cleanout openings clear thru matching panel cut-outs

and brass sample port plug clears panel matching hole.

7. Secure panel bottom to studs with acorn nuts hand tight.
8. Align upper panel attachment holes with smokebox upper attachment bosses and install 5/16"-18 x 1/2" Phillips pan head machine screws hand tight.
9. Securely tighten rear jacket panel mounting hardware.
10. Locate/remove four #8 x 1/2" shoulder sheet metal screws from Hardware Bag, then, install them into rear panel flange holes.

G. FLUE CLEANOUT COVERS AND SMOKEBOX COLLAR INSTALLATION.

1. Remove two cast iron Cleanout Covers, cast iron Smokebox Collar and the tube of hi-temperature silicon adhesive sealant from Part Carton. See also "Repair Parts" Section, "Bare Boiler Assembly" illustration for part identification.
2. Check the rope gasket factory attached to the covers. Repair or replace, if the rope is damaged, or, there is a gap between the rope ends.
3. Locate/remove four 5/16"-18 – 7/8" hex head cap screws from Hardware Bag.
4. Apply a drop of supplied Anti-seize (pouch provided in Part Carton) to each of four (4) 5/16"-18 x 7/8" hex head cap screws for rust protection and to facilitate easy removal for future service.
5. Position left Cleanout Cover over rear section cleanout opening, align section boss holes with Cleanout Cover holes, install both 5/16"-18 – 7/8"

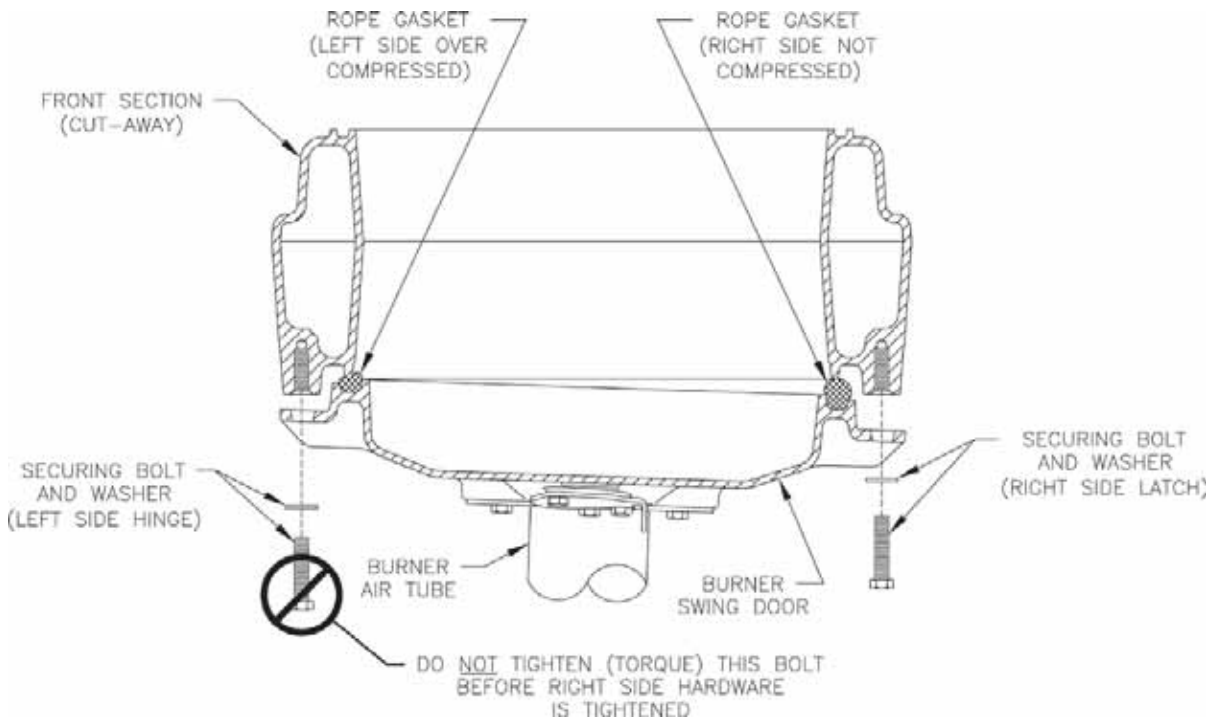

Figure 17: Top View - Burner Swing Door Fully Closed but Not Properly Secured or Sealed

hex head cap screws hand tight, then, alternately tighten them with open end or socket wrench.

6. Repeat above steps with right Cleanout Cover.
7. Apply the adhesive sealant to the underside of the collar, all around, at the inside corner of the collar outer ring. Insure adhesive bead is complete all around and without gaps.
8. Place the collar over smokebox tongue and align collar integral mounting ear slots with smokebox bosses.
9. Thread-in both 5/16"-18 – 7/8" hex head cap screws hand tight, then, alternately tighten them with open end or socket wrench.

H. INSULATION WRAPPER AND BURNER POWER OUTLET RECEPTACLE WITH HARNESS INSTALLATION.

1. Insulation Wrapper is packed in the Jacket Carton.
2. Unfold Insulation Wrapper, position it over section assembly centered left to right and align two wrapper upper holes with 2" NPT pipe tappings in front and rear section top.
3. Tuck Insulation Wrapper bottom ends under section assembly, between front and rear section legs.
4. Locate and remove Burner Power Outlet Receptacle with factory attached Burner Harness from Part Carton.
5. Feed Molex end of Burner Harness thru front jacket panel right side outlet receptacle cut-out. Insure that the receptacle middle prong opening is facing down. Snap the receptacle into front jacket panel. Temporarily, stuff Molex end of Burner Harness between front panel insulation and insulation wrapper near boiler top.

I. EXTERNAL ELECTRICAL ENCLOSURE MOUNTING.

1. Locate and remove Internal J-Box assembly from Part Carton.
2. Remove two #8 x 1/2" shoulder sheet metal screws and two snap bushings from Hardware Bag.
3. Secure the Internal J-Box with sheet metal screws to the top left corner of the Rear Jacket Panel.
4. Install snap bushings into front of J-Box and top right corner of Rear Jacket Panel.
5. Pick Molex connector end of Burner Harness and feed it inside the J-Box, thru bushed hole at the front of the J-Box.

J. TEMPERATURE / PRESSURE GAUGE.

1. Remove the Temperature / Pressure Gauge from Part Carton.
2. Thread the pressure gauge into 1/4" NPT tapping on top of the front section. Tighten with wrench applied to the square shank of the gauge.
3. Install snap bushing in cut-out located on Top Front Panel.

CAUTION

Do not apply pressure to gauge case, as this may result in inaccurate readings.

K. SIDE AND TOP JACKET PANEL INSTALLATION.

1. Pick up Side Jacket Panel from Jacket Carton. See also "Repair Parts" Section, "Jacket Assembly" illustration for part identification.
2. Place Side Jacket Panel over four #8 x 1/2" shoulder sheet metal screws, earlier installed at Front and Rear Jacket Panel side flanges, so teardrop cut-outs in the side panel inside flanges engage all four screws simultaneously.
3. Slide the panel downwards to lock all screws securely.
4. Repeat Steps 1 thru 3 for other Side Jacket Panel.
5. Pick up Molex end of Burner Harness stuffed between front panel insulation and insulation wrapper and feed it thru Internal J-Box front cut-outs.
6. Pick up Top Front Jacket Panel from Jacket Carton.
7. Place the panel between side panels upper inside flanges and slide it forward, until top panel front flange U-bend locks over front panel top flange, and, top panel rear flange is aligned with holes on Internal J-Box and Side Jacket Panels.
8. Locate/remove four #8 x 1/2" sheet metal screws from Hardware Bag.
9. Install four screws into top panel rear flange to secure the top panel to rear jacket panel.

L. FIELD ASSEMBLY OF BOILER TRIM, CONTROLS AND BURNERS.

Refer to Section II, Paragraph F.

SECTION IV: WATER BOILER PIPING

NOTICE

Failure to pipe boiler as specified in this manual may result in excessive system noise.

A. EVALUATE THE EXISTING WATER SYSTEM.

Design a piping system and install boiler which will prevent oxygen contamination of boiler water and frequent water additions.

1. There are many possible causes of oxygen contamination such as:
 - a. Addition of excessive make-up water as a result of system leaks.
 - b. Absorption through open tanks and fittings.
 - c. Oxygen permeable materials in the distribution system.
2. In order to insure long product life, oxygen sources must be eliminated. This can be accomplished by taking the following measures:
 - a. Repairing system leaks to eliminate the need for addition of make-up water.
 - b. Eliminating open tanks from the system.
 - c. Eliminating and/or repairing fittings which allow oxygen absorption.
 - d. Use of non-permeable materials in the distribution system.
 - e. Isolating the boiler from the system water by installing a heat exchanger.

B. CONNECT SYSTEM SUPPLY AND RETURN PIPING TO BOILER. See Figures 18A and 18B.

Also, consult I=B=R Installation and Piping Guides.

1. If this boiler is used in connection with refrigeration systems, the boiler must be installed so that the chilled medium is piped in parallel with the heating boiler using appropriate valves to prevent the chilled medium from entering the boiler. See Figure 19. Also, consult I=B=R Installation and Piping Guides.
2. If this boiler is connected to heating coils located in air handling units where they may be exposed to refrigerated air, the boiler piping must be equipped with flow control valves to prevent gravity circulation of boiler water during the operation of the cooling system.
3. If boiler is used with an Alliance SL™ Indirect-Fired Domestic Water Heater, install the Alliance SL™ as a separate heating zone. Refer to the Alliance SL™ Installation, Operating, and Service Instructions for additional information.
4. The MPO is designed to withstand thermal shock from return water temperatures as low as 100°F, but prolonged return temperatures of below 135°F can cause excessive flue gas condensation and damage the boiler and/or venting system.

Use a boiler bypass if the boiler is to be operated in a system which has a large volume or excessive radiation where low boiler water temperatures may be encountered (i.e. converted gravity circulation system, etc.) The bypass should be the same size as the supply and return lines with valves located in the bypass and return line as illustrated in Figures 18A and 18B in order to regulate water flow for maintenance of higher boiler water temperature.

WARNING

System supply and return piping must be connected to correct boiler manifolds.

Burnham recommends sizing the system circulator to supply sufficient flow (GPM) to allow a 20°F temperature differential in the system. When sizing the system circulator, the most restrictive single zone should be used to determine maximum pressure drop.

WARNING

The use of a low water cut-off device, while not required unless radiation level is below the boiler, is highly recommended.

If a low water cut-off is required, it must be mounted in the 3/4" supply manifold tapping (see Figures 7, 18A and 18B) or in the system piping above the boiler. The minimum safe water level of a hot water boiler is just above the highest water containing cavity of the boiler; that is, a hot water boiler must be full of water to operate safely.

CAUTION

Maintain minimum ½ inch clearance from hot water piping to combustible materials.

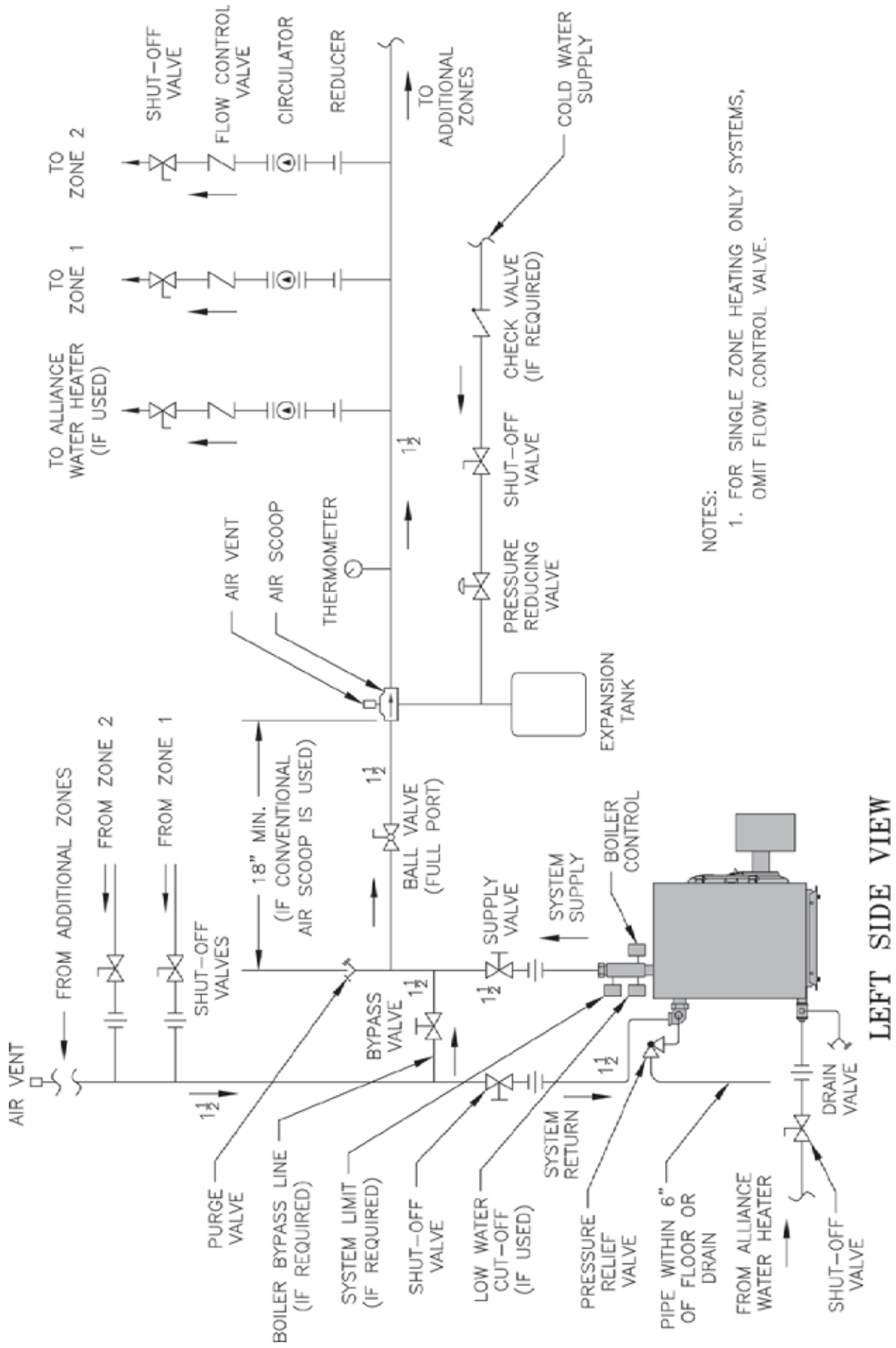

NOTES:
 1. FOR SINGLE ZONE HEATING ONLY SYSTEMS, OMIT FLOW CONTROL VALVE.

Figure 18A: Recommended Water Piping for Circulator Zoned Heating Systems

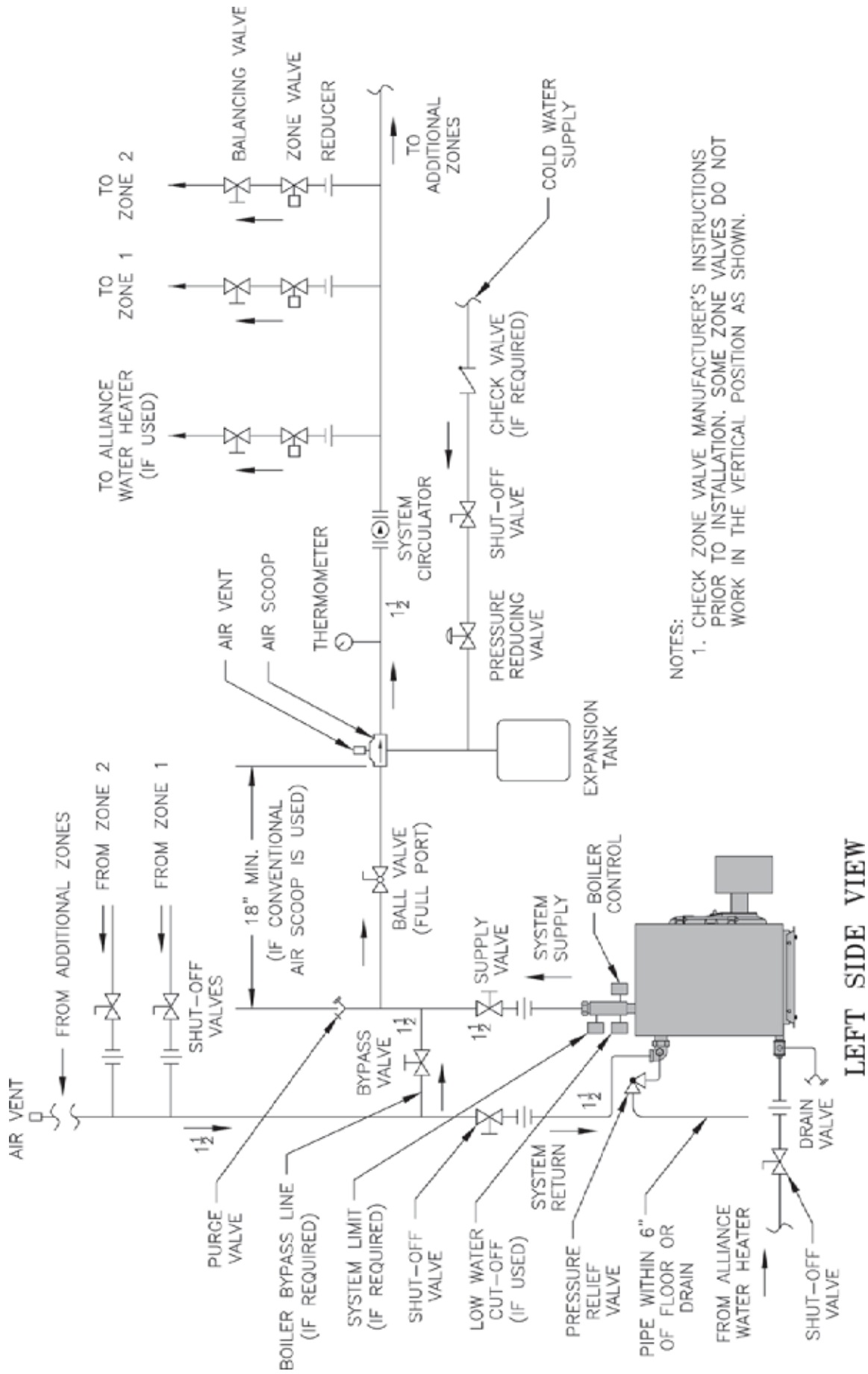

Figure 18B: Recommended Water Piping for Zone Valve Zoned Heating Systems

5. **If it is required to perform a long term pressure test of the hydronic system**, the boiler should first be isolated to avoid a pressure loss due to the escape of air trapped must first be removed from the boiler.

A loss of pressure during such a test, with no visible water leakage, is an indication that the boiler contained trapped air.

To perform a long term pressure test including the boiler, ALL trapped air must first be removed from the boiler.

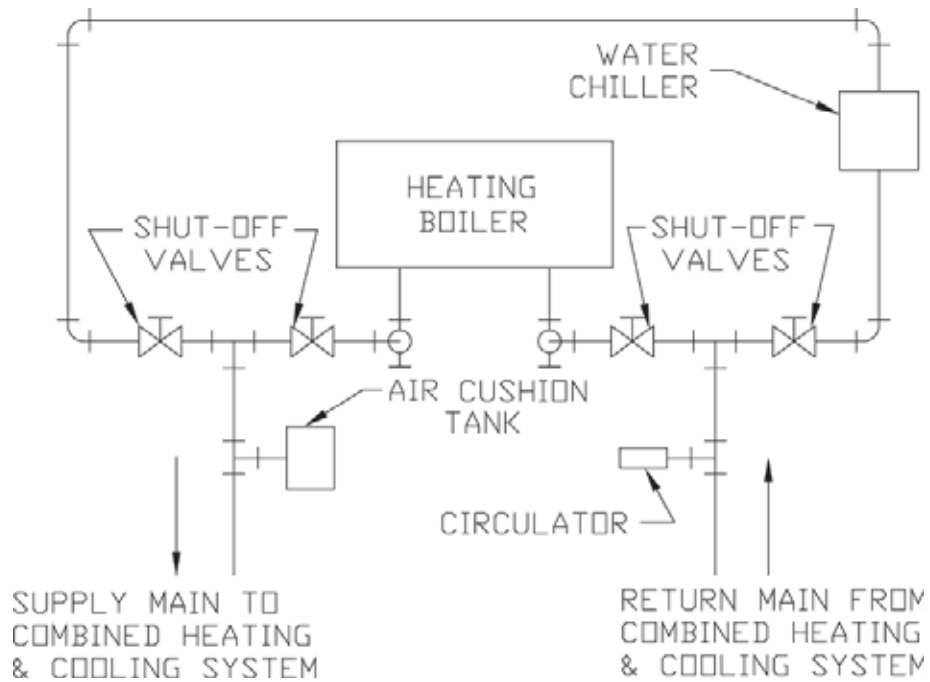

Figure 19: Recommended Piping for Combination Heating and Cooling (Refrigeration) System

SECTION V: INDIRECT WATER HEATER PIPING

A. CONNECT an Alliance SL™ WATER HEATER PIPING as shown in Figures 20A and 20B.

Also refer to Figures 18A and 18B.

1. Refer to Alliance SL™ instructions for additional information.

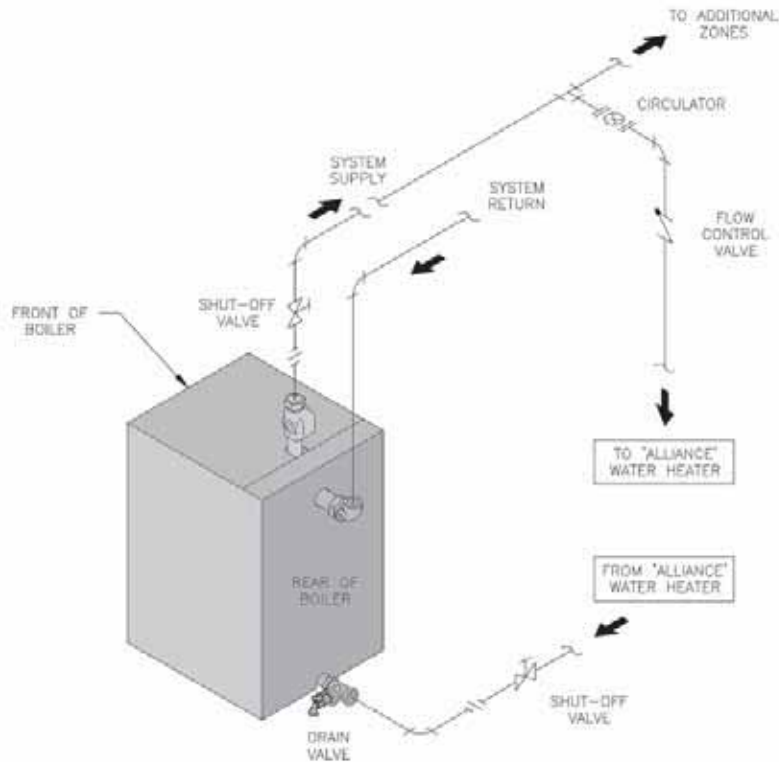

Figure 20A: Alliance SL™ Water Heater Piping w/Supply Side Circulator on Circulator Zoned Heating System

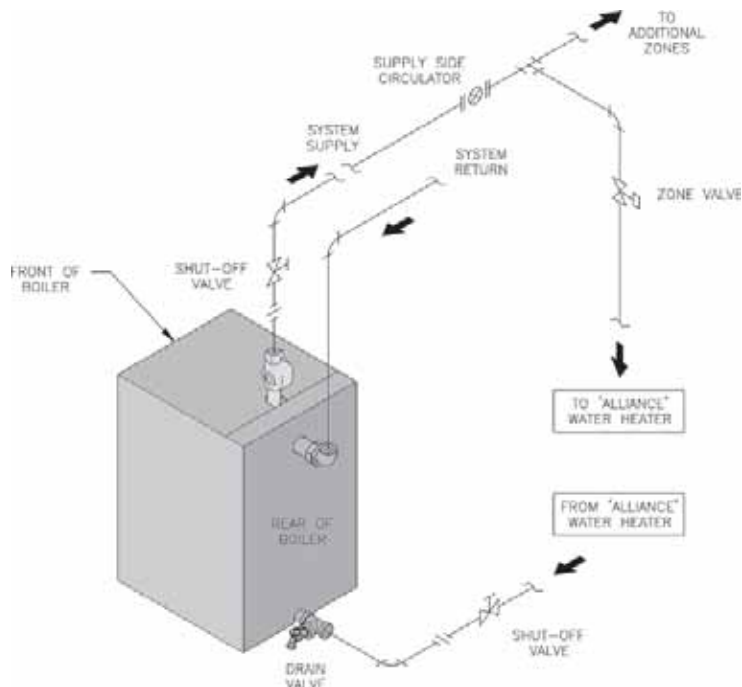

Figure 20B: Alliance SL™ Water Heater Piping w/Supply Side Circulator on Zone Valve Zoned Heating

SECTION VI: VENTING

A. CHIMNEY VENTING

1. Chimney venting is an important part of a safe and efficient oil fired appliance system. Contact your local fire and building officials on specific requirements for restrictions and the installation of fuel oil burning equipment. In addition, consult with a professional knowledgeable on the requirements of NFPA 31 – Standard for the Installation of Oil-Burning Equipment and NFPA 211 - Standard for Chimneys, Fireplaces, Vents, and Solid Fuel-Burning Appliances for installations in the United States. Installations in Canada must be reviewed with a professional knowledgeable on the requirements of CSA B139-04 – Installation Code for Oil-burning Equipment.
2. The safe venting of oil fired boilers is dependant on many factors. Some of these factors include:
 - a. sufficient draft during the entire heating season to allow for the safe discharge of combustion by-products and;
 - b. suitable corrosion protection in the event of condensing flue gases. Only a trained and qualified contractor may install this product.
3. The MPO can be vented into a fireclay tile-lined masonry chimney that meets requirements outlined in Paragraph 4 below. It can also be vented into a chimney constructed from type L vent or a factory built chimney that complies with the type HT requirements of UL 103. The chimney and vent pipe shall have a sufficient draft at all times, to assure safe proper operation of the boiler. See Figure 21 for recommended installation.

WARNING

Do not de-rate the appliance. Failure to fire the unit at it's designed input may cause excessive condensation upon the interior walls of the chimney. In addition, the lower input may not create enough draft to adequately evacuate the by-products of combustion.

4. Chimney Inspection – Prior to the installation of any new or replacement fuel burning equipment the chimney shall be inspected by a qualified installer. The chimney shall be inspected for integrity as well as for proper draft and condensate control. Some jurisdictions require the use of a liner when changing fuel types. Some jurisdictions require the use of a liner even when the same fuel is used. At a minimum, the chimney shall be examined by a qualified person in accordance with the requirements of Chapter 11 of NFPA 211, Standard for Chimneys, Fireplaces, Vents, and Solid Fuel-Burning Appliances.

- a. Loose Mortar – Loose mortar could be an indication of a prior history of condensing flue gases upon the inside walls of the chimney. Colder climates are more susceptible to this condition. Under no circumstances shall a chimney of this condition be used until it meets the requirements of NFPA 211 or CSA B139-04.
 - b. Unlined Chimney – Under no circumstances shall a chimney constructed of brick only be used. Only approved clay liners or listed chimney lining systems shall be used as specified in NFPA 31 or CSA B139-04.
 - c. Abandoned Openings – Openings through the chimney wall that are no longer used shall be sealed in accordance to NFPA 211. Often abandoned openings are improperly sealed and usually covered by a gypsum wall covering.
 - d. Clean Chimney – Chimney shall be free of all loose debris.
5. Draft Regulator – the draft regulator supplied with the boiler must be used with this appliance. No other draft regulator shall be used. Refer to Figures 21 and 22.

B. CHIMNEY CONNECTOR

1. A chimney connector (vent pipe) is used to connect the boiler to the base of the chimney. The chimney connector should be kept as short as possible. The horizontal length of the chimney connector shall not be greater than 10 feet.

NOTE: Secure chimney connector to cast iron smokebox collar with three (3) #10 x ½" self drilling hex head TEK screws provided in miscellaneous parts carton. Locate screws around perimeter of connector as shown in Figure 21 and approximately ½" in from edge. Use drill with 5/16" hex bit to drive screws through connector and smokebox collar.

DANGER

The chimney and connector shall be inspected annually for signs of debris and corrosion. Loose mortar at the base of the chimney may be a sign of condensate damage to the chimney. A chimney professional shall be contacted immediately to examine the damage and recommend a solution. Long term operation while in this condition may cause a venting failure and force flue gases into the living space. If the chimney is to be re-lined use the recommendations in NFPA 31, Appendix E or CSA B139-04.

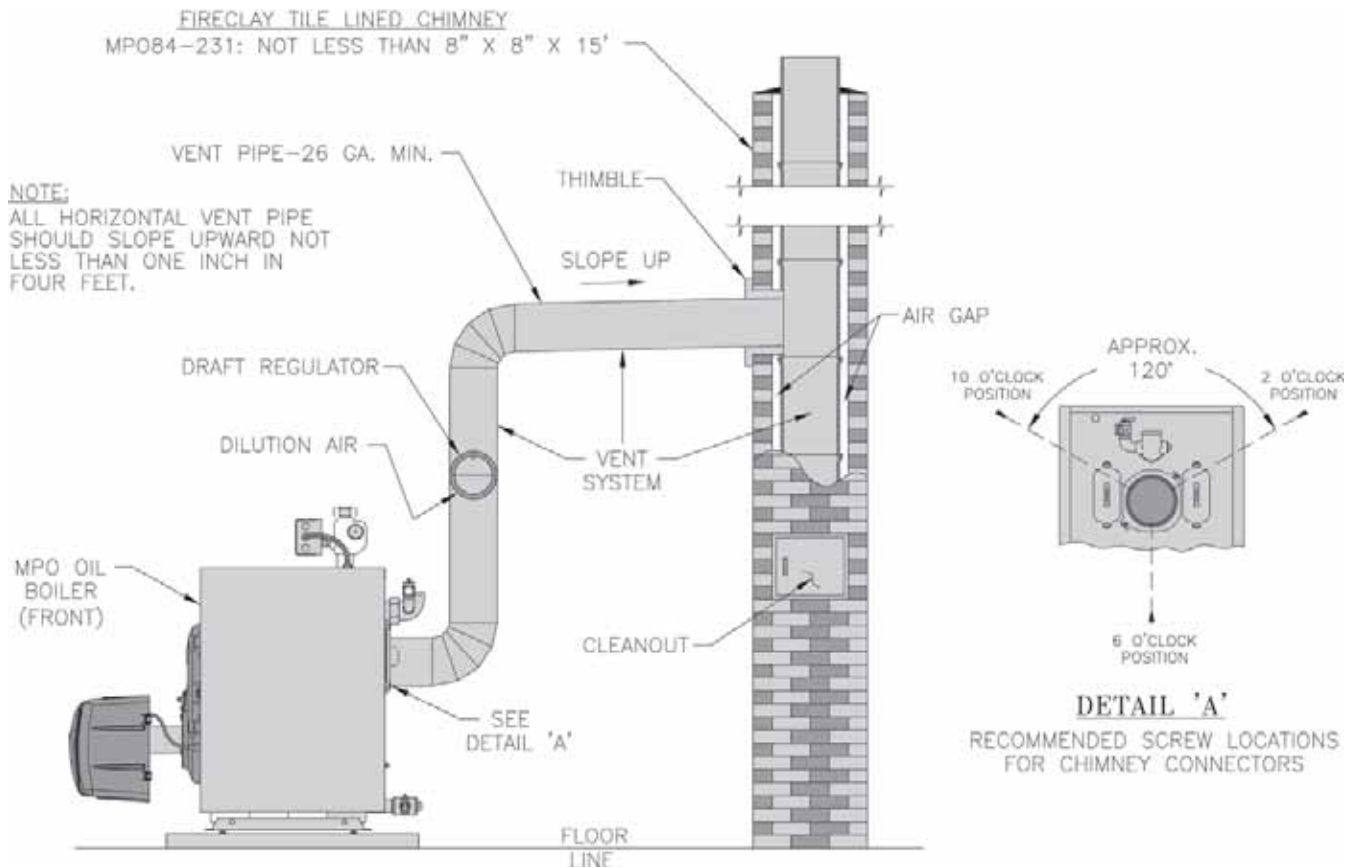

Figure 21: Recommended Vent Pipe Arrangement and Chimney Requirements

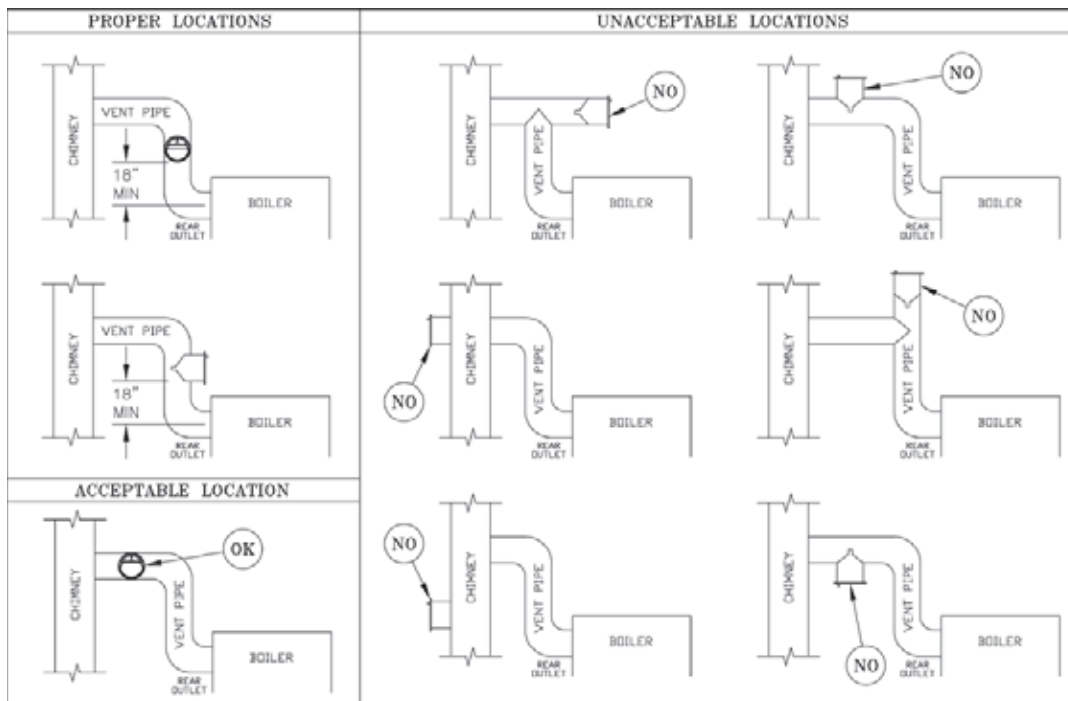

Figure 22: Proper and Improper Locations of Draft Regulator

2. Type B Chimney Connector - a type B chimney connector can be used to transmit the flue gases provided flue gas temperature entering the chimney connector is greater than 310°F.
3. Type L Chimney Connector - a type L vent or other suitable material shall be used for a chimney connector if the temperature or exiting temperature is less than 310°F.

DANGER

Any signs of condensate seepage at the base of the chimney shall be inspected immediately. The discoloration may be a sign of chimney damage and must be remedied immediately.

C. DRAFT

1. The natural draft generated through a chimney is dependent on several factors including, chimney height, temperature of flue gases, cross section area of chimney, chimney wall insulation value, dilution air and total volume of flue gases, to name a few. Make sure that the boiler has been running for at least 5 minutes before measuring the draft.
2. Minimum Draft at Breech (Canopy) – The draft induced by a chimney must create at least a pressure of 0 (zero) inches water column (“ w.c.”) at the pressure tapping on the canopy mounted on rear of boiler (see Figure 23). The pressure at the canopy **cannot** be positive since this could create a condition that allows flue gas by-products to escape from the draft regulator. A negative pressure reading up to -.03 inches water column is acceptable for proper operation. (See Table 6, Burner Specifications at the rear of this manual for more details)
3. Minimum Overfire Pressure – The overfire pressure is another piece of information that is often measured, however this should be done for observation purposes only! The breech pressure must be used to qualify the draft condition. See Table 6 for more details as a guide. Actual draft and temperature measurements may be different than those values in the table.

D. STACK TEMPERATURE

1. The temperature of the flue gases has a significant effect on the amount of draft created in a vertical chimney as well as the propensity to create condensate. The higher the stack temperature, the greater the amount of draft that can be generated. A lower stack temperature not only reduces the amount of draft that can be created but it also increases the possibility that the flue gases could condense in the chimney connector or stack.

2. NFPA 31 and CSA B139-04 have information to help the installer make an appropriate choice of venting materials. In some cases a chimney may have to be lined to create sufficient draft. In other cases, the chimney may have to be lined to prevent the corrosion of a masonry chimney. Consult with a chimney specialist knowledgeable on the requirements for chimney requirements in your area.

CAUTION

Any doubt on the condition of a chimney or its ability to prevent the generation and accumulation of flue gas condensate, must be relined according to NFPA 31 (United States) or CSA B139 (Canada).

CAUTION

Use the chimney venting tables as a guide. It is highly recommended that any borderline application should result in the relining of the chimney with a suitable liner that creates sufficient draft and to protect against corrosion caused by flue gas condensate.

3. Baffles – The efficiency of the boiler is based on the insertion of flue baffles supplied with your product. Under no circumstances are other baffles to be used on this product. The baffles are installed in the 2nd pass (two inner flueways) on the MPO147, MPO189 and MPO231. The baffles on the MPO84 are installed in the 3rd pass only. Refer to Section II, Item F, Paragraph 7 for baffle installation. If there is any doubt on the application of this boiler on the intended chimney, consult with your local code officials. At a minimum, remove the baffles to increase the stack temperature. See Table 6 for temperature differential (ΔT) with baffles IN and OUT. In addition, the lower the CO₂ level the higher the stack temperature.

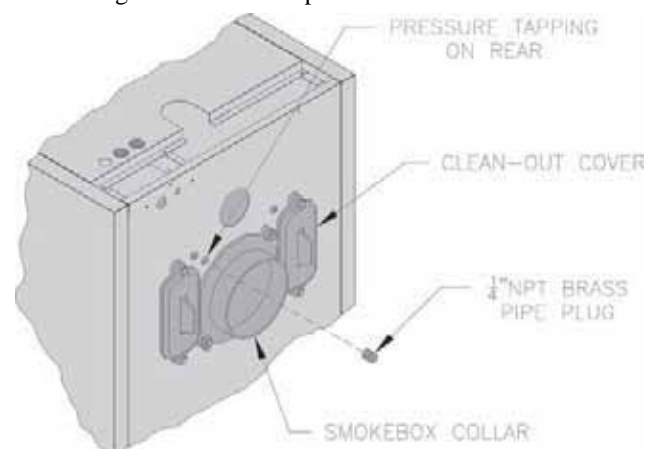

Figure 23: Smokebox Pressure Tapping for Checking Draft at Breech

WARNING

Remove the baffles if there are any signs of condensation in the chimney or chimney connector. Consult with your local chimney professional for recommendations.

E. MINIMUM CLEARANCES

See Figure 2A for details regarding clearances to combustibles for the boiler.

F. OPTIONAL AIR INTAKE PIPING

INSTALLATION - All air for combustion can be supplied directly to the burner from outdoors providing that the criteria for chimney, vent connector and minimum stack temperature outlined in this section can be maintained. **(ONLY AVAILABLE WITH BECKETT BURNER)**. Refer to Section I, Paragraph C, Steps 5 and 6 for optional air intake piping installation information.

WARNING

Using outdoor air in the middle of winter may result in lower stack temperatures and chimney degradation. Any signs of condensate seepage or discoloration at the base of chimney must be remedied immediately per the details outlined in this section.

Do not reduce size of air intake pipe.

Read, understand and follow combustion air instruction restrictions contained in the Pre-Installation Section of this manual.

SECTION VII: DIRECT VENTING / AIR INTAKE PIPING

A. GENERAL GUIDELINES

1. Direct Vent system must be installed in accordance with these instructions and applicable provisions of local building codes. Contact your local fire and building officials on specific requirements for restrictions and the installation of fuel oil burning equipment. In addition, for boiler installation in United States, consult with a professional knowledgeable on requirements of NFPA 31- Standard for the Installation of Oil-Burning Equipment and NFPA211- Standard for Chimney, Fireplaces, Vents and Solid Fuel-Burning Appliances, latest editions. Installations in Canada must be reviewed with a professional knowledgeable on requirements of CSA B139 – Installation Code for Oil-Burning Equipment, latest edition.
2. In the Direct Vent configuration, all air for combustion is supplied directly to the burner from outdoors, and, flue gases are vented directly outdoors (thru wall), via Direct Vent System (FDVS), which is a non-positive pressure vent system termination for oil-fired appliances, that provides an outlet for products of combustion, and, an intake for combustion air in a single concentric terminal.
3. Direct Vent Hood Assembly minimum clearance to combustible material is 0".

WARNING

This venting system must be installed by a qualified installer (an individual who has been properly trained) or a licensed installer.

DO NOT locate vent termination where exposed to prevailing wind. Moisture and ice may form on surfaces around vent termination. To prevent deterioration, surface must be in good repair (sealed, painted etc.).

DO NOT locate vent termination where petroleum distillates, CFC's, detergents, volatile vapors or any other chemicals are present. Severe boiler corrosion and failure will result.

DO NOT locate vent termination under a deck.

4. Vent Pipe minimum clearance to combustible material may be reduced to 1" when additional insulation added to cover exposed portion of vent termination inner pipe and appliance adapter. See Figure 2B.
5. Maximum wall thickness that FDVS vent termination may be installed through is 12".

6. Locate the vent terminal so vent pipe is short and direct, and, at the place on exterior wall that complies with the minimum distances as specified in Figure 24 and listed as follows. The vent termination must be located (as measured to the bottom of vent terminal):
 - a. Not less than 12" above finished grade or expected snow accumulation line whichever is greater.
 - b. Not less than 3 ft above any forced air inlet located within 10 ft.
 - c. Not less than 1 ft from any door, window or gravity air inlet.
 - d. Not less than 7 ft above grade when located above public walkway.
 - e. Not less than 3 ft (as measured to side of vent termination) from an inside corner of an L-shaped structure.
 - f. Not less than 1 ft from the nearest surface of the terminal to a roof soffit.
 - g. Not directly above, or, not less than 6 ft horizontally from an oil tank vent or gas meter.
 - h. Not less than 2 ft from nearest surface of terminal to an adjacent building.

B. INSTALLATION OF THE VENT HOOD TERMINAL

1. Inspect Direct Vent Conversion Kit Carton for damage. DO NOT install if any damage is evident.
2. Direct Vent Conversion Kit Carton includes (see Figures 26, 27 and 28):
 - Direct Vent Hood Assembly (consists of Vent Hood Body and Vent Hood Tee) – 1 pc
 - Backing Plate – 1 pc
 - Vacuum Relief Valve VRV-4 – 1 pc
 - Hardware Bag (includes high temperature sealant, fasteners and inner pipe clamps) – 1 pc
 - Appliance (Boiler Flue Outlet) Adapter – 1 pc
 - Appliance Clamp Halves – 2 pcs
 - Cover Sleeve Assemblies – 2 pcs
 - Cover Ring Assemblies – 2 pcs
3. Remove vent system components from carton and set aside.
4. Separate the vent hood tee from the vent hood body and set aside for later use.
5. After determining the location of the venting system termination, cut the square hole in the wall sized according to "L" dimension in Table 4, see Figure 25.
6. Wood or vinyl siding should be cut, so that vent hood base plate mounts directly on the wallboard to

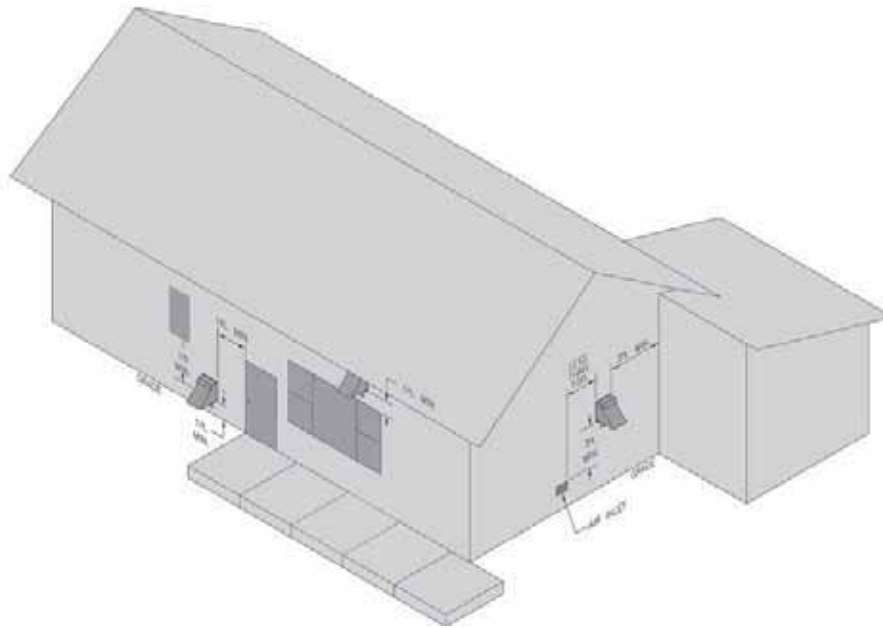

Figure 24: Vent Terminal Location

TABLE 4: WALL CUTOUT DIMENSIONS

Boiler Model No.	Direct Vent Conversion Kit Part No.	"L" Dimension (Inch)
MPO147 MPO189	102130-02	8 $\frac{1}{4}$
MPO231	1021300-03	9 $\frac{1}{4}$

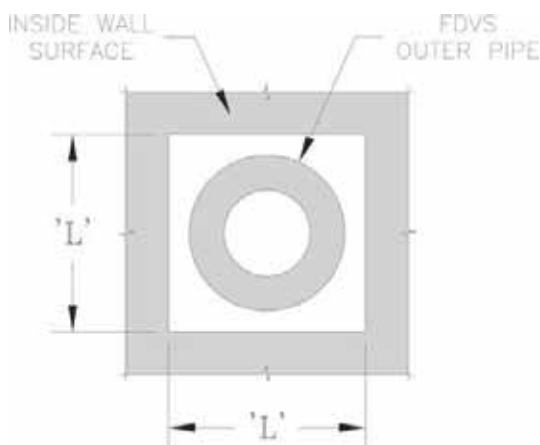

Figure 25: Wall Cutout Dimensions

provide stable support. If siding thickness exceeds $\frac{1}{2}$ ", use a spacer bar or board behind the vent hood mounting (base) plate. See Figure 26.

- Seal the backside of the vent hood base plate around the outer pipe of the vent hood with a bead of high-temperature silicone sealant (provided in Bagged Hardware).
- Mount the vent hood body from outside, through the wall, keeping the outer pipe centered in the hole.

- Fasten the vent hood body to the outside wall with appropriate fasteners (installer provided).
- Seal the edges of the vent hood base plate to the wall with a high-temperature silicone sealant (provided in Bagged Hardware).
- While inside, position the backing plate over the outer pipe and fasten to inside wall with appropriate fasteners (installer provided).

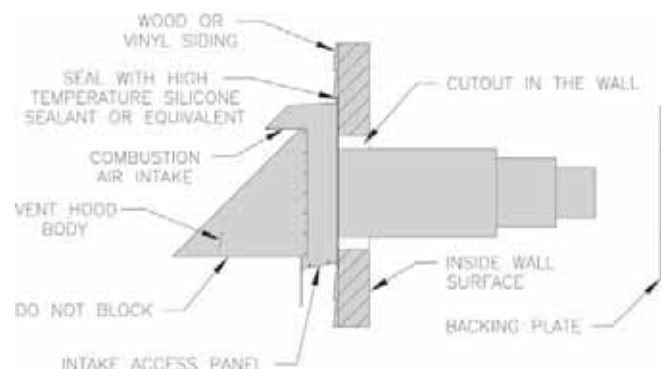

Figure 26: Vent Hood Body Installation

C. INSTALLATION OF VENT HOOD TEE

- Assemble the vent hood tee body to the vent hood outer pipe, and, rotate the tee, so air intake inlet collar is in the desired position. See Figure 27.
- Attach the vent hood tee body to the vent hood outer pipe with at least three sheet metal screws (installer provided).

Note: The tee may be rotated into any position so that the collar is in a convenient orientation.

- After completing assembly of the flexible double wall insulated vent pipe to the vent termination inner pipe (see Figure 28 and the following Steps), apply

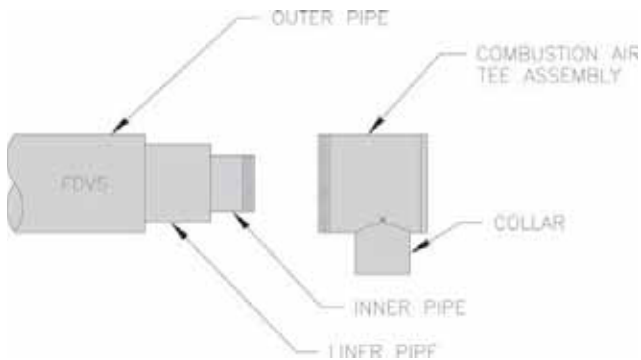

Figure 27: Combustion Air Tee Assembly Installation

the supplied high temperature sealant to seal around the inner pipe protrusion thru the vent tee cover pan, around the joint between the vent tee collar and the vent tee body, and, seal or tape the joint between the vent termination outer pipe and the vent tee body.

D. INSTALLING THE FLEX OIL VENT PIPE FROM THE VENT TERMINATION TO THE BOILER FLUE OUTLET

1. The venting system (vent pipe and all connectors) shall be installed in accordance with the applicable provisions of any local codes, and, in United States, requirements of NFPA 31- Standard for the Installation of Oil-Burning Equipment and NFPA211- Standard for Chimney, Fireplaces, Vents and Solid Fuel-Burning Appliances, latest editions.

- For installations in Canada, follow requirements of CSA B139 – Installation Code for Oil-Burning Equipment, latest edition.
2. A vent pipe connector, designed for positive pressure venting, shall be supported for the design and weight of material employed, to maintain clearances, prevent physical damage and separation of joints. All joints **MUST BE** sealed, for positive vent pressure, to prevent flue gas leakage into the structure.
 3. Support the vent pipe at intervals no greater than three (3) feet apart using perforated metal strap or other non-combustible supports.
 4. Allow sealant to cure at least one hour before firing boiler.
 5. Route the vent pipe from the vent termination to the boiler using the minimum number of bends possible. The last horizontal section of the vent pipe should have a slight downward slope from the boiler to the vent termination. For clearances to combustible materials refer to Figure 2B.
 6. Maximum length of flexible oil vent pipe is 20 ft. The vent pipe is also available pre-cut in 5 ft, 10 ft and 15 ft increments.
 7. Verify that flex vent pipe diameter and vent termination inner pipe diameter correspond to a particular direct vent configuration MPO boiler model (see Table 5).

TABLE 5: FLEX VENT/VENT TERMINATION PIPE DIAMETERS

Boiler Model No.	Boiler Flue Outlet Collar OD (Inch)	Vent Hood Inner Pipe Diameter (Inch)	Flex Oil Vent Pipe Inner Pipe Diameter (Inch)	* Flue Outlet Collar to Vent Pipe Adapter (Inch)
MPO147	6	5	5	6 to 5
MPO189				
MPO231	7	6	6	7 to 6

NOTE: * The model specific Direct Vent (FDVS) Kit Cartons contain adapters (reducers) (see Table 5) to connect boiler flue outlet collar to vent pipe.

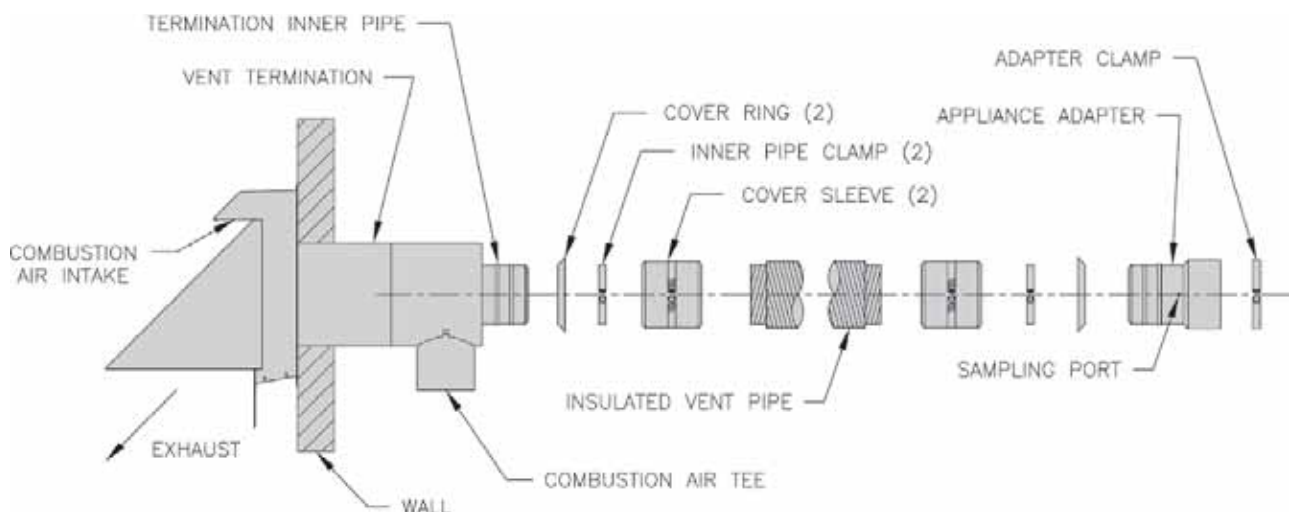

Figure 28: FDVS Component Breakdown

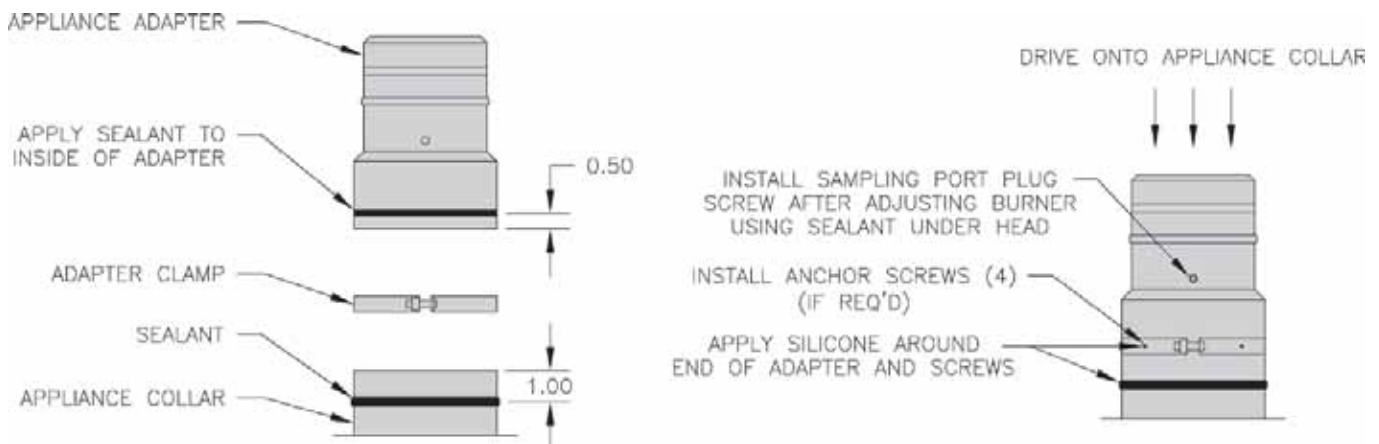

Figure 29: Appliance Adapter Installation

E. CONNECTING APPLIANCE ADAPTER TO BOILER FLUE OUTLET COLLAR

(See Figure 29)

1. Apply a bead of supplied high temperature sealant to boiler flue outlet collar approximately 1" from collar end.
2. Remove any oil and grease from inside of supplied Appliance (Boiler Flue Outlet) Adapter, and, apply a bead of high temperature sealant to inside of the adapter, ½" from end.
3. With twisting motion, assemble the appliance adapter onto boiler flue outlet collar.
4. Using a mallet and a block of wood, carefully tap the adapter onto the outlet collar. Insure no damage is done to the adapter and the flue outlet collar.
5. Assemble supplied adapter clamp halves with 5/16-18 bolts and square nuts; install the adapter clamp onto the appliance adapter and tighten securely.
6. If required, install anchoring screws (installer provided) thru four holes in the clamp into the flue outlet collar.
7. Apply sealant around the adapter end mated to the flue outlet collar.
8. Install supplied 3/8" sampling port plug screw hand tight into the adapter sampling port.
9. **After initial boiler start-up and burner testing/adjustment are completed,** apply high temperature sealant under the head of sampling port plug screw, and, install the screw in the sampling port tightening securely.

F. CONNECTING FLEX OIL VENT PIPE TO APPLIANCE ADAPTER AND DIRECT VENT TERMINATION

1. Flexible double wall oil vent pipe is available pre-cut from 5 ft to 20 ft long. If necessary, the vent pipe may be cut to required length with a hacksaw or cutoff saw.

CAUTION

Use safety glasses and other appropriated safety gear when cutting the vent pipe.

2. The double wall flexible vent pipe consists of the smaller inner corrugated stainless steel pipe and larger corrugated aluminum pipe, separated by fiberglass insulation layer.

CAUTION

The inner and outer pipe ends may have sharp burrs. Use gloves, while handling, compressing or expanding the vent pipe.

3. Pull outer vent pipe back 1" to 2" from end of inner vent pipe and remove insulation; firstly, at vent pipe side to be connected to the vent termination; secondly, at vent pipe side to be connected to the appliance adapter. See Figure 30.

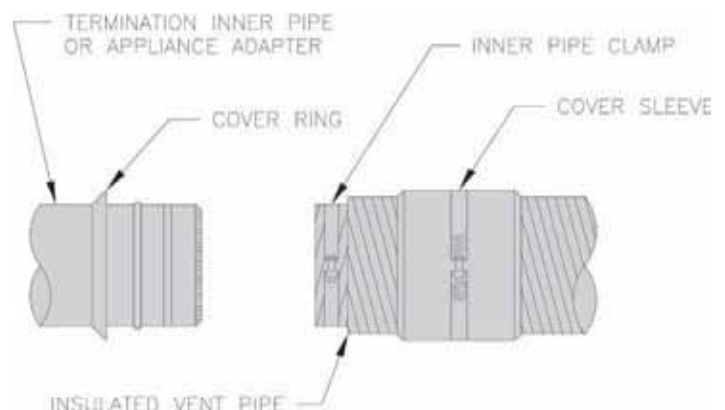

Figure 30: Vent Pipe Assembly to Vent Termination Inner Pipe and Appliance Adapter

4. Install supplied Cover Sleeve Assembly onto each end of outer vent pipe, and, move the assembly a few inches back from the end; firstly, at vent pipe side to be connected to the vent termination;

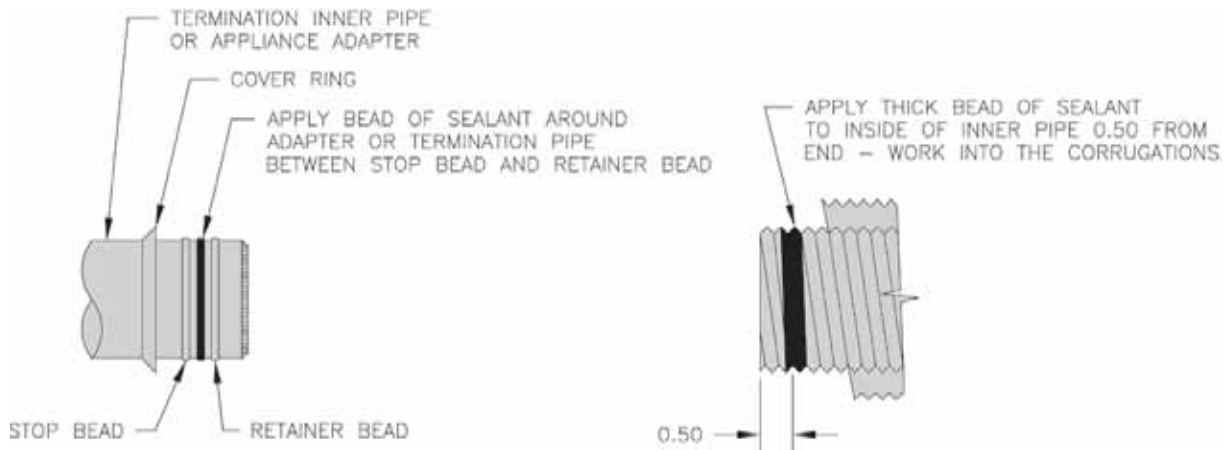

Figure 31: Vent Pipe Ends, Vent Termination and Appliance Adapter Sealing

secondly, at vent pipe side to be connected to the appliance (boiler outlet collar) adapter. See Figure 30.

5. Slide supplied Cover Rings; firstly, over stop bead on vent termination inner pipe; secondly, over stop bead on appliance adapter. See Figure 30.
6. Remove any oil and grease from the end of vent termination inner pipe, and, from the end of the appliance adapter.
7. Apply sealant; firstly, between the stop bead and retainer bead at the end of the vent termination inner pipe; secondly, between the stop bead and retainer bead at the end of the appliance adapter. See Figure 31.
8. Assemble supplied inner pipe clamp halves with 1/4-20 bolts and square nuts; position the inner pipe clamps 1/4" from the end of inner vent pipe, on vent pipe opposite ends.
9. Remove any oil and grease from inside of each end of the inner vent pipe.
10. Apply a thick bead of sealant to inside of each end of the inner vent pipe, 1/2" from pipe end, working the sealant into the inner vent pipe corrugations. See Figure 31.
11. Firstly, push one end of the inner vent pipe onto the vent termination inner pipe, all the way up to the stop bead. Secondly, push the opposite end of the inner vent pipe onto the appliance adapter, all the way up to the stop bead.
12. Tighten the inner pipe clamp bolts at both vent pipe ends, until clamp halves are within 1/8" apart. See Figure 32.
13. Starting with vent termination end, slide the cover sleeve assembly and the cover ring together to engage the ring in the groove of the sleeve, then, tighten the built-in cover sleeve clamp. Repeat above steps at the boiler end. See Figure 32.
14. If the appliance collar is within less than 18" of combustible material, wrap minimum 1-1/2" thick fiberglass insulation (installer provided).

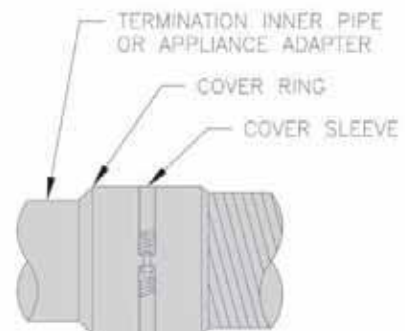
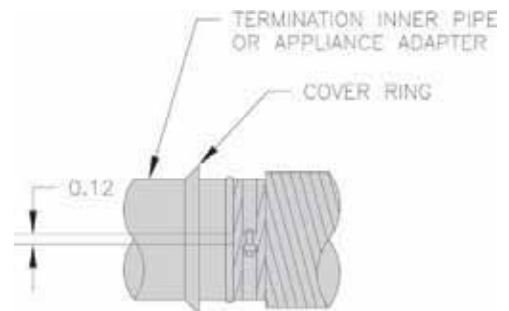

Figure 32: Vent Pipe Assembly to Vent Termination Inner Pipe & Appliance Adapter

15. To maintain vent pipe 1" clearance to combustible material, wrap minimum 1-1/2" thick fiberglass insulation (installer provided) around the exposed portion of the vent termination inner pipe and secure with adhesive-backed aluminum foil tape (installer provided).

G. INSTALLING THE AIR INTAKE PIPING FROM DIRECT VENT TERMINATION TO NX BURNER OUTSIDE AIR ADAPTER

1. Use 4" diameter galvanized single wall vent pipe and fittings, available at most heating distributors, to connect NX burner outside air adapter to Direct Vent Termination air intake collar.
2. Maximum air intake pipe length is 40 equivalent feet.

WARNING

DO NOT reduce size of air intake pipe.

3. Start at burner and work towards Direct Vent termination air intake.
4. Remove burner cover. Loosen two screws securing outside air duct bracket to burner cover mounting plate. See Figure 33.
5. Procure a 2-ft section of 4" diameter galvanized single wall vent pipe, cut off the crimped pipe end below stop bead.
6. Insert one end of the vent pipe thru the outside air duct bracket opening and firmly push onto the outside air adapter collar.
7. Secure the pipe to collar with at least (3) sheet metal screws (installer provided) evenly spaced around the collar.
8. Re-tighten the screws securing outside air duct bracket to burner cover mounting plate.
9. Install supplied vacuum relief valve tee assembly, crimped end down, into the opposite end of vent pipe.
10. Secure the tee to the pipe with at least (3) sheet metal screws (installer provided) evenly spaced.
11. Remove the vacuum relief valve gate assembly from the tee.
12. Assemble the vacuum relief valve balance weight onto the gate. Refer to the vacuum relief valve manufacturer's instructions for details.
13. Mount the assembled vacuum relief valve gate with balance weight into the tee and fasten with a screw and nut in collar tabs. To insure proper operation, the gate must be level across the pivot point and plumb. Refer to the vacuum relief valve manufacturer's instructions for details.
14. Install remainder of air intake piping to Direct Vent Termination air intake collar, securing each joint with at least (3) sheet metal screws (installer provided) evenly spaced.
15. Maintain ¼" per foot slope in horizontal run to air intake of Direct Vent Termination.
16. Support the air intake piping, as required, using perforated metal strap or other supports.

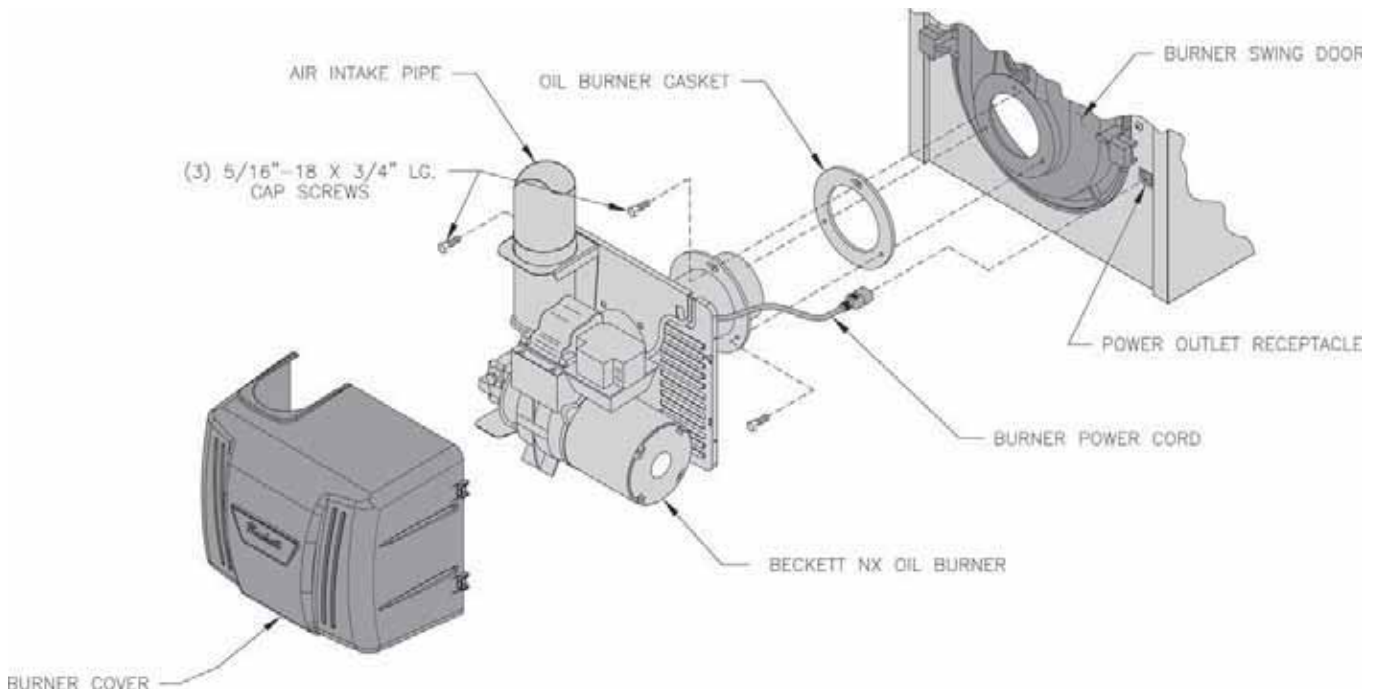

Figure 33: Oil Burner Installation

SECTION VIII: ELECTRICAL

DANGER

Positively assure all electrical connections are unpowered before attempting installation or service of electrical components or connections of the boiler or building. Lock out all electrical boxes with padlock once power is turned off.

WARNING

Failure to properly wire electrical connections to the boiler may result in serious physical harm.

Electrical power may be from more than one source. Make sure all power is off before attempting any electrical work.

Each boiler must be protected with a properly sized fused disconnect.

Never jump out or make inoperative any safety or operating controls.

A. GENERAL

1. Install wiring and electrically ground boiler in accordance with requirements of the authority having jurisdiction, or in absence of such requirements the National Electrical Code, ANSI/NFPA 70, and/or the CSA C22.1 Electric Code.
2. Refer to National Electric Code or Local Electric Codes for proper size and type of wire required. Follow Code.
3. A separate electrical circuit must be run from the main electrical service with an over-current device/disconnect in the circuit. A service switch is recommended and may be required by some local jurisdictions.
4. Use anti-short bushings on all wiring passing through boiler jacket, junction boxes and/or control boxes.
5. Use armored cable (BX) over all exposed line voltage wiring.

6. If an Alliance SL™ water heater is used, use priority zoning. Do not use priority zoning for Hydro-Air Systems.

7. Wiring should conform to Figure 34A or 34B.

- B. INSTALL A ROOM THERMOSTAT** on an inside wall about four feet above floor. Never install thermostat on an outside wall or where it will be influenced by drafts, hot or cold water pipes, lighting fixtures, television, rays of the sun or near a fireplace. Keep large furniture away from thermostat so there will be free movement of room air around this control.

Heat Anticipator in Thermostat should be set to match the requirements of the control to which it is connected. See Figure 34A or 34B for desired system and heat anticipator setting. If system tends to overheat above the thermostat's temperature setting, reduce heat anticipator setting by .1 or .2 amps. If system tends to short cycle without reaching desired room temperature, increase heat anticipator setting by .1 or .2 amps.

SECTION IX: OIL PIPING

A. GENERAL

1. Use flexible oil line(s) so the burner swing door can be opened without disconnecting the oil supply piping.
2. A supply line fuel oil filter is recommended as a minimum for all firing rates but a pleated paper fuel oil filter is recommended for the firing rates below 1.0 GPH to prevent nozzle fouling.
3. Use Flared fittings only. Cast iron fittings cannot be used.

NOTICE

Do not use compression fittings.

Oil piping must be absolutely airtight or leaks or loss of prime may result. Bleed line and fuel unit completely.

Refer to your local jurisdictions regarding any special considerations for fuel supply requirements. In addition, refer to NFPA 31, Standard for the Installation of Oil-Burning Equipment for Installations in the United States and CSA B139-04 for Installation in Canada.

4. Use of a high efficiency micron filter (Garber or equivalent) in addition to a conventional filter is highly recommended.
5. Piping used to connect the oil burner to the oil supply tank shall not be smaller than 3/8" iron pipe or 3/8" OD copper tubing. Copper tubing shall have a .032" minimum wall thickness.

WARNING

Under no circumstances can copper with sweat style connectors be used.

NOTICE

Some jurisdictions require the use of a fusible shutoff valve at the tank and/or the burner. In addition, some jurisdictions require the use of a fusible electrical interlock with the burner circuit. Check your local Codes for special requirements.

B. SINGLE PIPE OIL LINES

1. Standard burners are provided with single-stage 3450 RPM fuel units with the bypass plug removed for single-pipe installations.
2. The single-stage fuel unit may be installed single-pipe with gravity feed or lift. Maximum allowable lift is 8 feet. See Figure 35.
3. Fuel Oil Line Deaerator – On many occasions a leaky oil delivery line can introduce air into the fuel oil supply system. This often creates a rough starting condition and can create a burner lockout state. In addition to fixing the leak, a fuel line deaerator can be installed to eliminate air. The single line from the fuel tank is connected to the deaerator. The burner pump must be connected to the deaerator as a two pipe system. Follow the oil pump manufacturer's recommendations for conversion to a two pipe system.

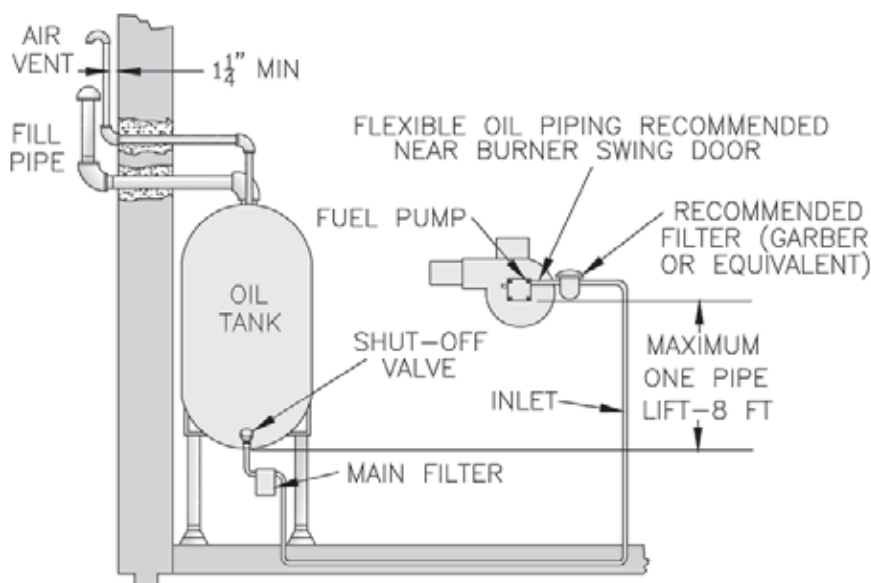

Figure 35: Single Pipe Oil Line

C. TWO PIPE OIL LINES

1. For two piped systems, where more lift is required, the two-stage fuel unit is recommended. Table 6 (two-stage) and Table 7 (single-stage) show allowable lift and lengths of 3/8 inch and 1/2 inch OD tubing for both suction and return lines. Refer to Figure 36.
2. Follow the oil pump manufacturer's recommendations on the proper connections for a two pipe system. Some manufacturers require the insertion of a bypass plug.

3. Under no circumstances is a manual shutoff valve to be located on the return line of a two pipe system. Accidental closure of the return line will rupture the oil pump seals.

TABLE 6: TWO-STAGE UNITS (3450 RPM) - TWO PIPE SYSTEMS

Lift "H" (See Fig. 25)	Maximum Length of Tubing "H" + "R" (See Figure)	
	3/8" OD Tubing (3 GPH)	1/2" OD Tubing (3 GPH)
0'	93'	100'
2'	85'	100'
4'	77'	100'
6'	69'	100'
8'	69'	100'
10'	52'	100'
12'	44'	100'
14'	36'	100'
16'	27'	100'
18'	---	76'

TABLE 7: SINGLE-STAGE UNITS (3450 RPM) - TWO PIPE SYSTEMS

Lift "H" (See Fig. 25)	Maximum Length of Tubing "H" + "R" (See Figure)	
	3/8" OD Tubing (3 GPH)	1/2" OD Tubing (3 GPH)
0'	84'	100'
1'	78'	100'
2'	73'	100'
3'	68'	100'
4'	63'	100'
5'	57'	100'
6'	52'	100'
7'	47'	100'
8'	42'	100'
9'	36'	100'
10'	31'	76'
11'	26'	100'
12'	21'	83'
13'	---	62'
14'	---	41'

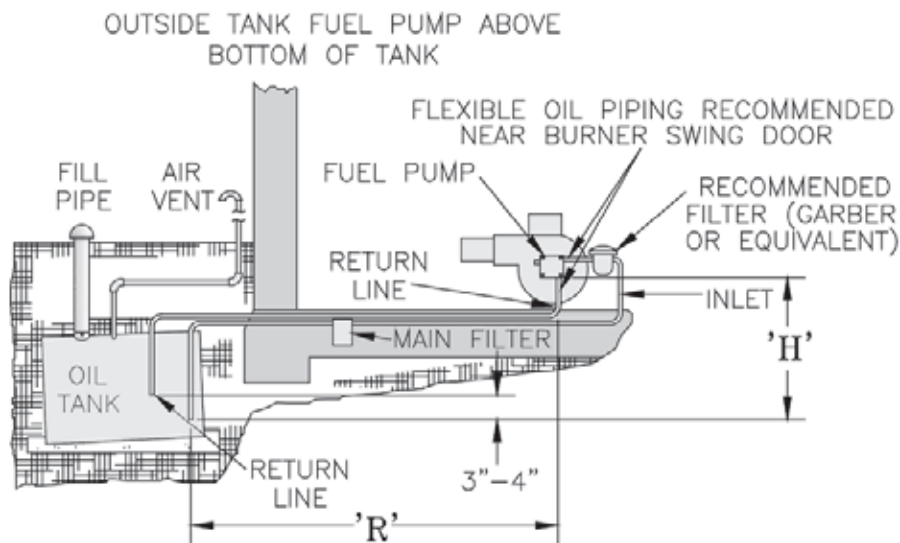

Figure 36: Two Pipe Oil Lines

SECTION X: SYSTEM START-UP

WARNING

All boilers equipped with burner swing door have a potential hazard which can cause severe property damage, personal injury or loss of life if ignored. Before opening swing door, turn off service switch to boiler to prevent accidental firing of burner outside the combustion chamber. Be sure to tighten swing door fastener completely when service is completed. In addition, the burner power cord will have to be disconnected from the receptacle in the front jacket.

A. ALWAYS INSPECT INSTALLATION BEFORE STARTING BURNER.

1. Verify that the venting, water piping, oil piping, and electrical system are installed properly. Refer to Installation Instructions contained in this manual.
2. Confirm all electrical, water and oil supplies are turned off at the source and that the vent is clear from obstructions.

WARNING

Completely read, understand and follow all instructions in this manual before attempting start up.

B. FILL HEATING SYSTEM WITH WATER.

NOTICE

It is important to properly remove the oil and dirt from the system. Failure to clean the system can result in clogged air vents, circulator damage and seized zone valves.

CLEAN HEATING SYSTEM if boiler water is dirty.

Refer to Maintenance and Service Instructions Section of this manual for proper cleaning instructions for water boilers.

1. **HOT WATER BOILERS.** Fill entire heating system with water and vent air from system. Use the following procedure on a series loop or multi-zoned system installed as per Figures 18A and 18B, to remove air from system when filling:
 - a. Close full port ball valve in boiler system piping.
 - b. Isolate all zones by closing zone valves or shut-off valves in supply and return of each zone(s).
 - c. Attach a hose to vertical purge valve in boiler system supply piping up stream from the full port ball valve.
(Note - Terminate hose in five gallon bucket at a suitable floor drain or outdoor area).
 - d. Starting with one zone at a time, open zone valve or shut-off valve in boiler supply and return piping.

- e. Open purge valve.
- f. Open shut-off valve in cold water supply piping located between the air scoop and expansion tank.
- g. Allow water to overflow from bucket until discharge from hose is bubble free for 30 seconds.
- h. When zone valve is completely purged of air, close zone valve or shut-off valve. Open zone valve to the next zone to be purged. Repeat this step until all zones have been purged. At completion, open all zone valves.
- i. Close purge valve, continue filling the system until the pressure gauge reads 12 psi. Close shut-off valve in cold water supply piping.

WARNING

The maximum operating pressure of this boiler is posted on the ASME Data Label located on the top of the boiler. Never exceed this pressure. Do not plug relief valve.

NOTICE

If make-up water line is equipped with pressure reducing valve, system will automatically fill to 12 psi. Follow fill valve manufacturer's instructions.

- j. Open full port ball valve in boiler system piping.
- k. Remove hose from purge valve.
- l. Confirm that the boiler and system have no water leaks.
- m. It may be necessary to clean the air vent assembly after a few days of operation.

C. CHECK CONTROLS, WIRING AND BURNER

to be sure that all connections are tight and burner is rigid, that all electrical connections have been completed and fuses installed, and that oil tank is filled and oil lines have been tested.

D. ADJUST CONTROL SETTINGS with burner service switch turned "ON".

1. **SET ROOM THERMOSTAT** about 10°F below room temperature.

2. PRESS RED RESET BUTTON on front of burner cover (Beckett, Riello burners), hold button for one (1) second and release to reset primary control.
3. On WATER BOILERS WITHOUT TANKLESS HEATERS equipped with L7248 electronic aquastat controller, set High Limit (HL) at 180°F. This temperature can be varied to suit installation requirements. L7248 controller has the High Limit adjustment range from 180°F to 240°F (82°C to 116°C). High Limit Differential is fixed at 15°F (8°C).
4. ADJUSTING AQUASTAT CONTROLLER SETTINGS. To discourage unauthorized changing of Aquastat settings, a procedure to enter the ADJUSTMENT mode is required. To enter the ADJUSTMENT mode, press the UP, DOWN, and I buttons (refer to Figure 37) simultaneously for three seconds. Press the I button until the feature requiring adjustment is displayed:

- HL — High Limit.

Then, press the UP and/or DOWN buttons to move the set point to the desired value. After 60 seconds without any button inputs, the control will automatically return to the RUN mode.

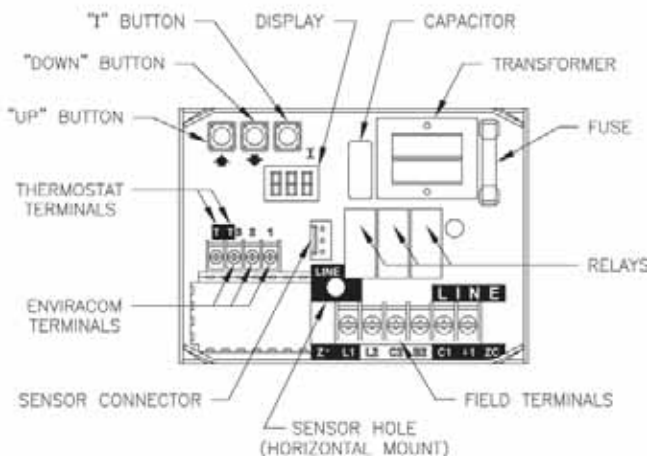

Figure 37: L7248 Circuit Board Layout - Horizontal Mount

5. DISPLAY READOUT

In the RUN mode, the Aquastat will flash "bt" (boiler temp) followed by the temperature (i.e., 220), followed by °F or °C.

To read boiler settings, press the I key to read the parameter of interest. For example, press I High Limit (HL) is displayed, followed by a three-digit number, i.e., 220, followed by °F or °C. See Display Readout, Figure 38.

After approximately 60 seconds without any key presses, the display will enter a dim display mode. To return to the bright display mode, simply press any key.

Text	Description	Display Shows
bt	Boiler Temperature	bt
HL	High Limit	HL
tt	Local Thermostat Status	tt
tte	EnviraCom Thermostat Status	tte
err	Error Code	Err
f	Degrees Fahrenheit	°F
C	Degrees Celsius	°C

Figure 38: Display Readout Definitions

6. OPERATION

The L7248 model is restricted to three operational states - Normal, High Limit and Error. The controller moves back and forth from High Limit to Normal state as part of normal operation.

For both models, the controller will enter the Error state when there is an abnormal condition. The operating states are:

- a. Normal: Boiler temperature went below the High Limit setting (minus the Differential) and has not exceeded the High Limit setting; or the boiler temperature went above the Low Limit setting and has not gone below the Low Limit setting (minus the Differential).
- b. High Limit: Boiler temperature went above the High Limit setting and has not dropped below the High Limit setting (minus the Differential).
- c. Error: The controller has detected an error condition (e.g., open sensor) and has shut down the burner output. The ZC output is energized. The controller continues to monitor the system and automatically restarts if the error condition clears. Refer to Table 8.

The operating sequence for the L7248 is shown in Table 9.

TABLE 8: LED ERROR CODES

Error Code	Cause / Action
Err1	Sensor fault; check sensor.
Err2	ECOM fault; check EnviraCOM™ wiring.
Err3	Hardware fault; replace control.
Err4	B1 fault; check B1 wiring/voltage.
Err5	Low Line; check L1-L2, 110 Vac.
Err6	Fuse; check ECOM wires, replace fuse.
Err7	EEPROM, HL, Hdf; reset to default values. Restore desired settings.
Err8	Repeated B1 fault (voltage present at B1 when output is turned off); check B1 wiring/voltage.

TABLE 9: L7248 CONTROLLER OPERATING SEQUENCE

Action	System Response
Thermostat calls for heat.	Circulator starts when water temperature is above Low Limit setting (if applicable). Boiler temperature is checked. Burner starts when water temperature is below High Limit setting.
Boiler exceeds the High Limit.	Burner is turned off. Burner restarts when the water temperature drops below the High Limit setting minus the Differential.
Thermostat is satisfied.	Circulator and burner turn off.
Error condition 1-5.	If an error condition is detected, all outputs except ZC are shut down. Burner is off. Control continues to function and restarts when error is corrected. During the error check sequence, the system checks for drift in the sensor and corrosion in the connections.
Error condition 6.	EnviraCOM communication is not available.
Error condition 7.	The control has reset the High Limit setting to a default setting and will continue to run at those settings. Performance of the system will be degraded.
Error condition 8.	If the error condition is detected, all outputs except ZC are shut down. Burner is off. Control continues to function and restarts when all three user keys have been pressed longer than 60 seconds.

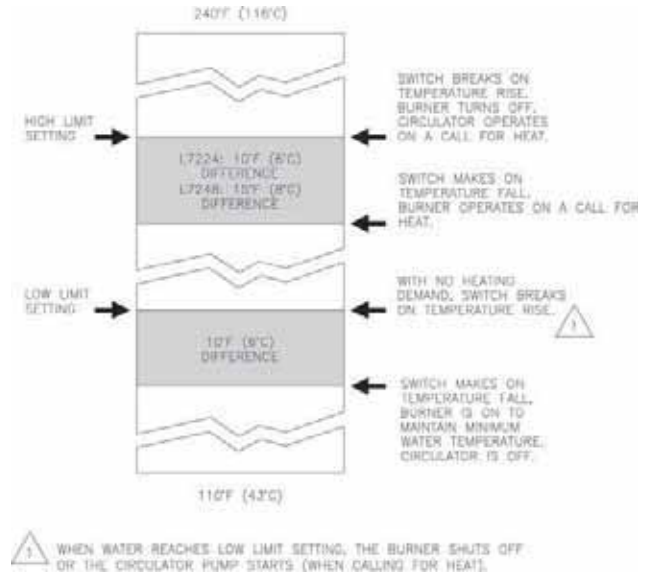

Figure 39: Setpoints and Differentials

Natural Vent Application

E. ADJUST OIL BURNER BEFORE STARTING.

1. CHECK BURNER AIR BAND AND AIR SHUTTER, readjust if necessary, see Table 13 at rear of manual.
2. **Beckett Burners**
 - a. Inspect Beckett head setting on left side of burner by insuring the blue line MD(V1) or the line on the label MB(L1) are aligned, readjust if necessary.
 - b. OPEN ALL OIL LINE VALVES.
 - c. Attach a plastic hose to fuel pump vent fitting and provide a pan to catch the oil.
 - d. OPEN FLAME OBSERVATION PORT COVER on burner swing door.
3. **Riello Burners**
 - a. OPEN ALL OIL LINE VALVES.
 - b. Provide a pan to catch oil.
 - c. Remove pressure port/bleeder plug from fuel pump and install Riello Combination Pressure Gauge and Bleeder Valve Assembly.
 - d. OPEN FLAME OBSERVATION PORT COVER on burner swing door.

F. START OIL BURNER.

1. Open vent fitting on fuel pump.
2. PRESS RED RESET BUTTON on front of burner cover, hold for one (1) second and release to reset primary control.
3. TURN 'ON' BURNER service switch and allow burner to run until oil flows from vent fitting in a SOLID stream without air bubbles for approximately 10 seconds.

7. HIGH LIMIT CONTROLLER

The High Limit opens and turns off the burner when the water temperature reaches the setpoint. The High Limit automatically resets after the water temperature drops past the setpoint and through the Differential. The L7248 models have High Limit Differential presets of 15°F (8°C). Refer to Figure 39.

8. CHECKOUT

Put the system into operation and observe at least one complete cycle to make sure that the controller operates properly. See Step 9, TROUBLE SHOOTING to use LED to assist in determining system operation.

9. TROUBLE SHOOTING

When attempting to diagnose system performance, reference to the LED display can help to identify specific areas not working properly. The LED display will scroll **Err**, followed by a digit (1-8). Refer to Table 8 for a description of each error and suggested actions.

NOTE: For Primary Control "Pump Priming Cycle" details, see Paragraph I, No. 2., Step a., Item ii .

4. Close vent fitting and burner flame should start immediately after prepurge is completed. Prepurge prevents burner flame until 15 seconds has elapsed after initial power is applied to burner. During prepurge the motor and igniter will operate but the oil valve will remain closed. Refer to Oil Primary Control Instructions for more details.
5. Adjust oil pressure.
 - a. When checking a fuel unit's operating pressure, a reliable pressure gauge may be installed in either the bleeder port or the nozzle port. See Figure 40.

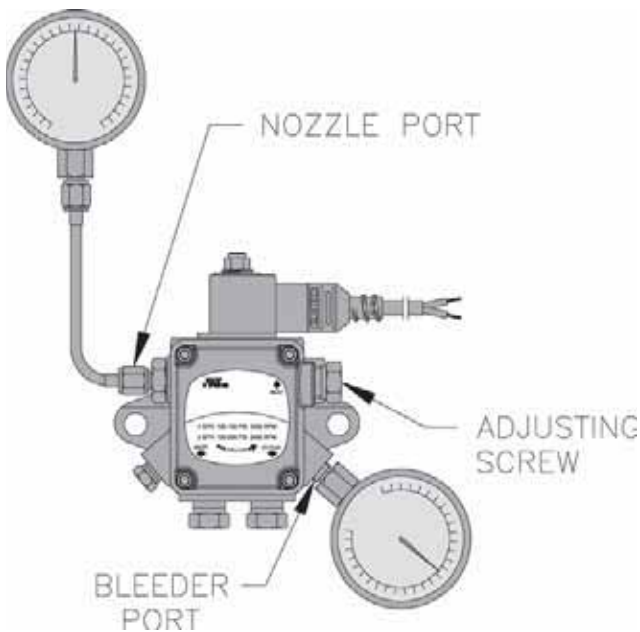

Figure 40: Adjusting Fuel Pump Pressure

- b. Locate oil pressure adjusting screw and turn screw to obtain proper pump pressure, refer to Table 13 at rear of manual.
- c. To check the cut-off pressure, deadhead a reliable pressure gauge onto the copper connector tube attached to the nozzle port. Run the burner for a short period of time. Shut the burner off. The pressure should drop and hold.
- d. Remove the gauge and install bleeder port and/or reconnect the nozzle port line.

G. ADJUST OIL BURNER WHILE OPERATING. (flame present)

1. **ADJUST DRAFT REGULATOR** for a draft of zero inches (water gauge) in the canopy (see Figure 23) after chimney has reached operating temperature and while burner is running. (At least five minutes) See Table 13 at rear of manual for details.

2. **READJUST THE AIR BAND** on burner for a light orange colored flame while the draft in the canopy is zero inches water column ("w.c.). Use a smoke tester and adjust air for minimum smoke (not to exceed #1) with a minimum of excess air. Make final check using suitable instrumentation to obtain a CO₂ of 11.5 to 12.5% with draft of zero inches water column ("w.c.) (water gauge) in canopy. These settings will assure a safe and efficient operating condition. If the flame appears stringy instead of a solid fire, try another nozzle of the same type. Flame should be solid and compact. After all adjustments are made recheck for a draft of zero inches water column ("w.c.) in the canopy. Replace plug at completion.

See Table 13 (at rear of this manual) for details regarding the overfire pressure when baffles are both installed and removed.

3. **READJUST THE HEAD SETTING** only if necessary.
 - a. MPO84 & MPO147:
Beckett MB(L1 & L2) Head burners have a fixed head which are non-adjustable.
 - b. MPO189 & MPO231:
Beckett MD(V1) (variable) Head burners have the ability to control air by moving the head. It might be necessary to move the head forward or back one position at a time to optimize the smoke and CO₂ readings. See Figure 41.
4. **Riello Burners**
 - a. MPO147 thru MPO231
Move the turbulator setting forward or back one position at a time to optimize the smoke and CO₂ readings.
 - b. Turn "OFF" burner and remove Riello Combination Pressure Gauge and Bleeder Valve Assembly. Install pressure port/bleeder plug and tighten. Start burner again.
5. **TURN "OFF" BURNER** and remove pressure gauge. Install gauge port/bleeder plug and tighten. Start burner again.

WARNING

Do not loosen or remove any oil line fittings while burner is operating.

6. **FLAME FAILURE**
The MPO boiler controls operate the burner automatically. If for unknown reasons the burner ceases to fire and the reset button on the primary control has tripped, the burner has experienced ignition failure.

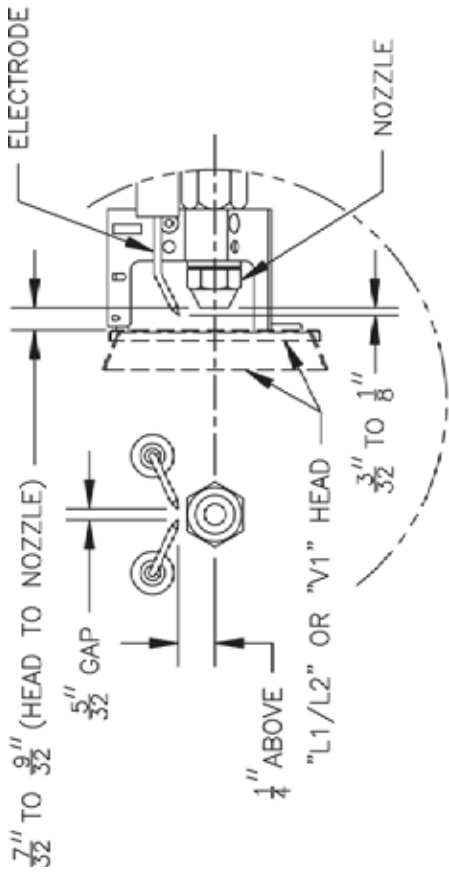

ELECTRODE ADJUSTMENT
(FOR ALL MODELS)

**FIXED HEAD SETTING FOR
MP084 AND MP0147 WITH
L2 AND L1 HEADS RESPECTIVELY**

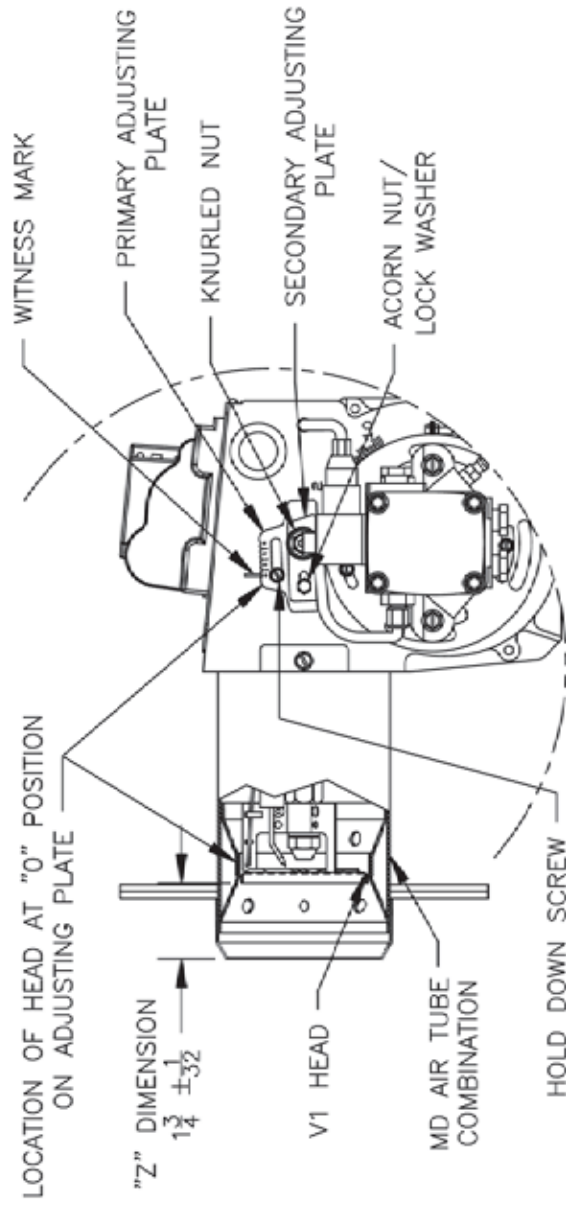
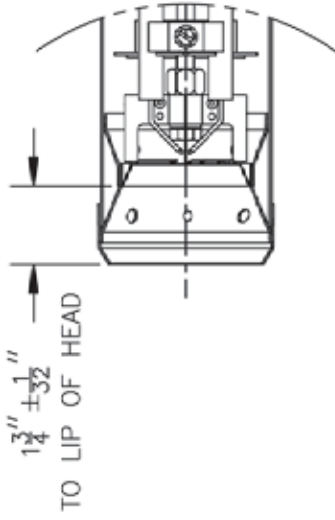

**HEAD SETTING (AT "0") FOR
MP0189 AND MP0231 WITH V1 HEAD**

Figure 41: "L1/L2" and "V1" Head Electrode Positioning and Gun Setting (Beckett AFG)

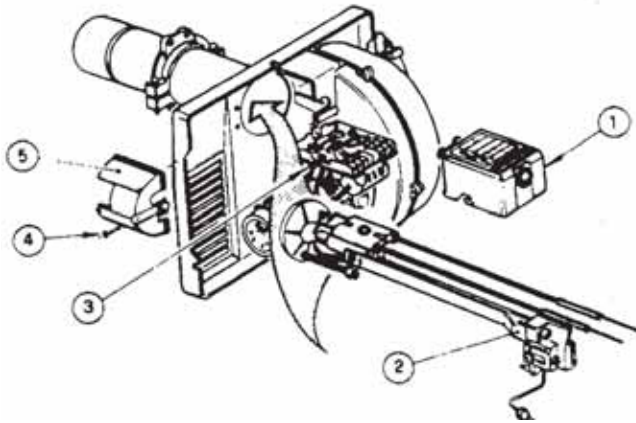

Figure 41A: Installation/Removal of Drawer Assembly

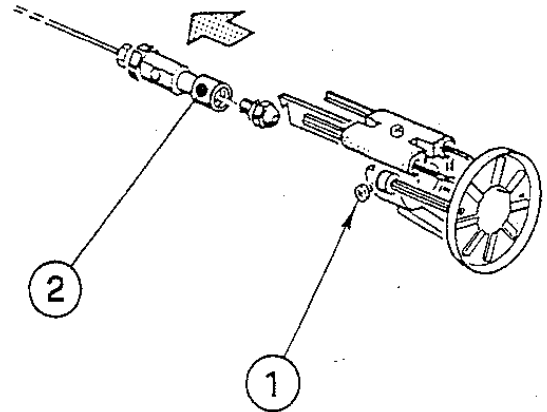

Figure 41B: Nozzle Replacement

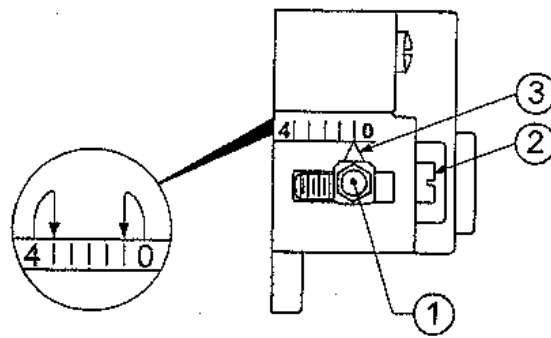

Figure 41C: Turbulator Setting

IMPORTANT: THESE DIMENSIONS MUST BE OBSERVED AND VERIFIED.

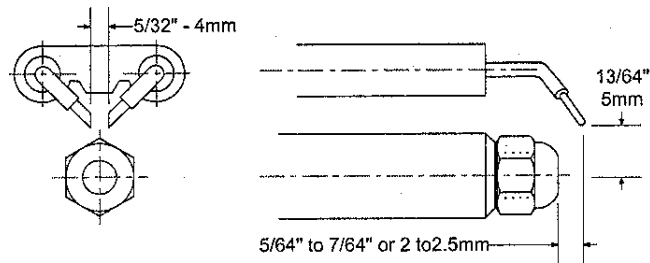
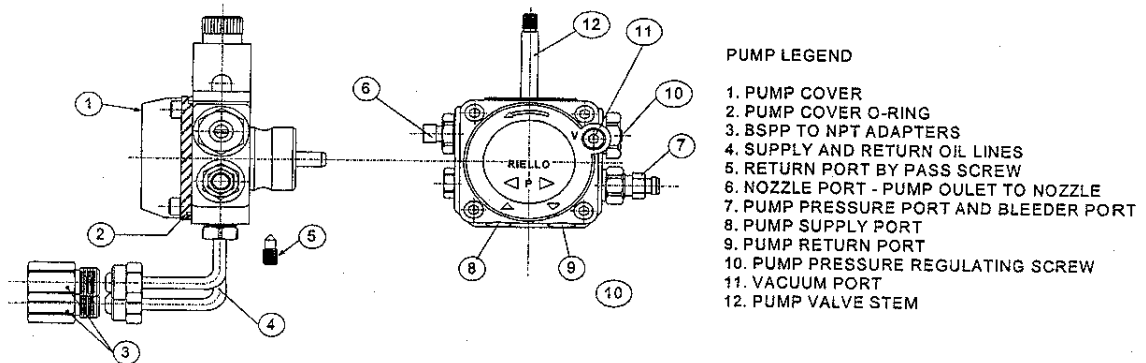

Figure 41D: Electrode Positioning (Riello 40 Series)



PUMP LEGEND

- 1. PUMP COVER
- 2. PUMP COVER O-RING
- 3. BSPP TO NPT ADAPTERS
- 4. SUPPLY AND RETURN OIL LINES
- 5. RETURN PORT BY PASS SCREW
- 6. NOZZLE PORT - PUMP OULET TO NOZZLE
- 7. PUMP PRESSURE PORT AND BLEEDER PORT
- 8. PUMP SUPPLY PORT
- 9. PUMP RETURN PORT
- 10. PUMP PRESSURE REGULATING SCREW
- 11. VACUUM PORT
- 12. PUMP VALVE STEM

Figure 41E: Pump Connections and Port Identification

WARNING

Do not attempt to start the burner when excess oil has accumulated, when the unit is full of vapor, or when the combustion chamber is very hot.

Direct Vent Application

H. CHECK/ADJUST OIL BURNER BEFORE STARTING.

VERIFY BURNER SETTINGS - refer to Table 10 .

1. Turn off power to burner before proceeding.
2. Remove burner cover by loosening the four thumb screws and set aside.
3. Disconnect the copper oil connector tube from nozzle line.
4. Loosen the two screws securing igniter-retaining clips and rotate both clips to release the igniter baseplate. The igniter should pop-up and would be supported by the prop spring.
5. Lift up the igniter baseplate and verify that a burner has factory installed Low Fire Rate Baffle, if applicable. See Table 10 and Figure 42.

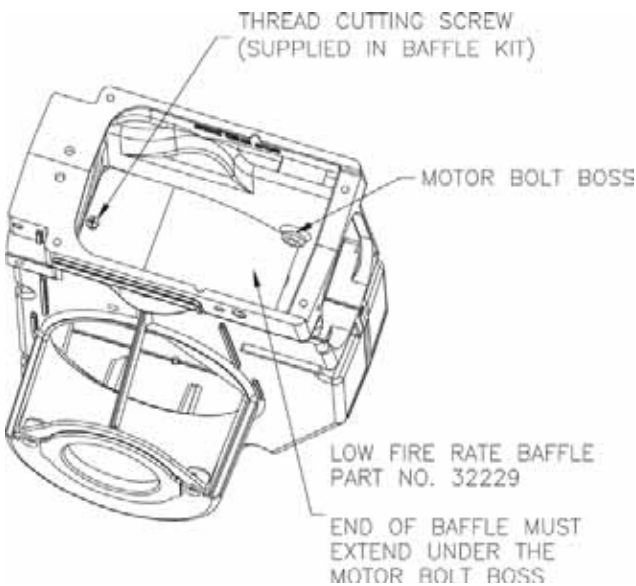

Figure 42: Mounting Low Fire Rate Baffle in Burner Housing

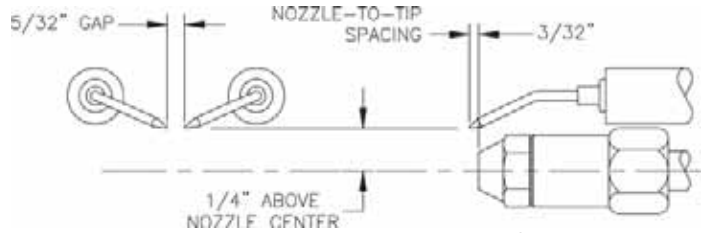

Figure 43: Electrode Tip Gap and Spacing

10. Check retention head alignment. Cad cell sighting holes in the throttle cup and retention head must line up, so the cad cell can see the flame. Make sure that the “stamped key” in the retention head collar lines up with the “keyway” in the nozzle adapter, when mounting the retention head. See Figure 44.

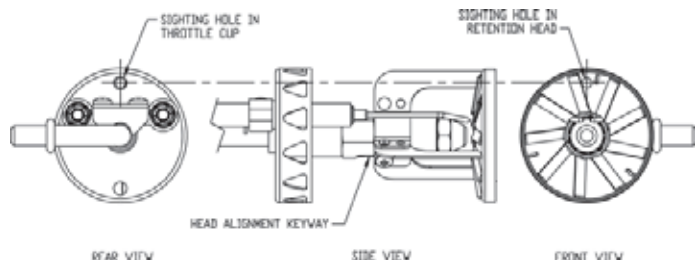

Figure 44: Retention Head/Throttle Cup Alignment

11. To re-install the nozzle line assembly, reverse steps 7 thru 3.
12. Upon reinstallation of the nozzle line assembly, check that head/air plate setting number pointer lines up with a number on the scale, which matches a value shown in Table 10 for a particular boiler/ burner model.

TABLE 10: BECKETT NX BURNER SETTINGS

Boiler Model	Firing Rate (GPH)	Burner	Air Tube	Oil Nozzle	Settings	
					Head/Air Plate Setting Number	Pump Pressure (PSIG)
MPO147	1.05	NX	NX70LB	Hago 0.85 - 60°B	2.75	150
MPO189	1.35	NX	NX90LD	Hago 1.00 - 45° B	1.00	180
MPO231	1.65	NX		Hago 1.25 - 45° B	2.25	

The zero calibration has been factory set; the upper left acorn nut locks retention head at “0” position. If the zero calibration has to be reset, follow the adjustment procedure, outlined at “Prepare Burner & Site” section of Beckett Model NX Oil Burner Instruction Manual, Form Number 610BNX. Make sure the retention head is securely against the stops in the retention ring, when the adjustment plate pointer is at “0”.

13. The rear door must be kept tightly closed upon reinstallation of the nozzle line assembly.
14. Loosening the splined nut and lower acorn nut, and, turning the adjustment screw, either forward or, rearwards, will adjust the head/air plate. **DO NOT LOOSEN UPPER LEFT ACORN NUT**, which locks zero head/air setting. See Figure 45.

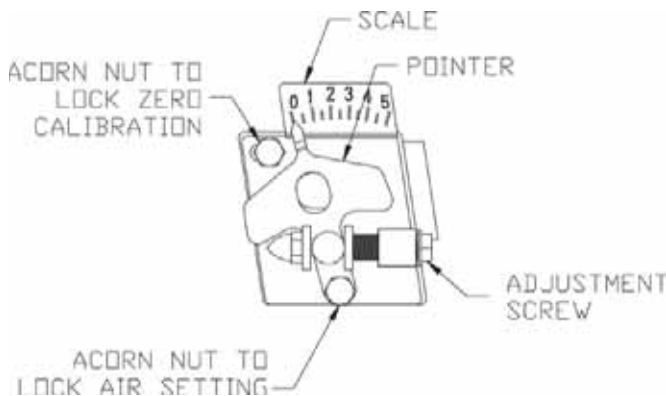

Figure 45: Head/Air Adjustment Plate Assembly

15. OPEN ALL SHUT-OFF VALVES in the oil supply line to the burner.
16. ATTACH A PLASTIC HOSE TO FUEL PUMP VENT/BLEED FITTING and place the other hose end into an empty container to catch the oil.
17. SLIGHTLY OPEN FLAME OBSERVATION PORT COVER on burner swing door, enough to insert draft gauge probe later.

WARNING

Very hot flue gases come out of flame observation port cover hole when boiler is operated with port cover open. Always wear proper eye protection.

I. START OIL BURNER.

1. OPEN VENT FITTING on fuel pump.
2. PRESS RED RESET BUTTON on burner primary control, hold for one second and release to reset the control.
3. CLOSE THE SERVICE SWITCH to start the burner. The burner primary control has 15 sec. prepurge timing preventing burner flame after initial power is applied to burner. During prepurge the motor and igniter will operate, but the oil valve will remain closed. Refer to Oil Primary Control Instructions for more details.

Note: For Primary Control “Pump Priming Cycle” details see Paragraph I, No. 2, Step a, Item ii.

4. BLEED THE FUEL PUMP when the burner motor starts rotating. Continue to bleed for 15 seconds after oil is free from air bubbles. Tighten the vent fitting when all air is purged. **NOTE:** Bleeding might not be needed with a two-pipe system. When vent fitting is closed, burner flame should start immediately.
5. INSTALL PRESSURE GAUGE
 - a. Open service switch and shut off burner.
 - b. Either, remove plastic hose and oil pump vent fitting, then, install a reliable pressure gauge into vent fitting port, or, install the gauge into the nozzle port. See Figure 46.
 - c. Re-start burner.

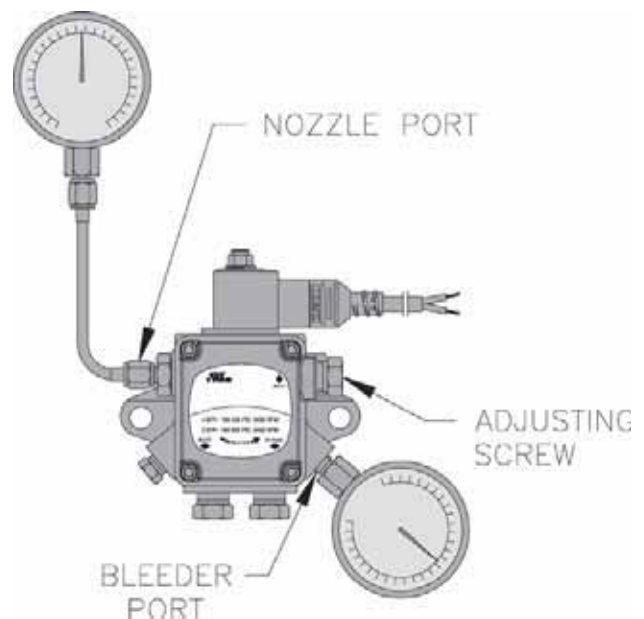

Figure 46: Checking/Adjusting Fuel Pump Pressure

6. CHECK/ADJUST OIL PRESSURE WHILE OPERATING (Flame present)
 - a. Check oil pressure to correspond to a specified value for a particular MPO boiler model. Refer to Table 10.
 - b. If adjustment needed, locate oil pressure adjusting screw and turn screw to obtain oil pressure specified.

J. ADJUST OIL BURNER WHILE OPERATING. (flame present)

1. ADJUST AIR SETTING on burner for a light orange colored flame. Flame should be solid and compact. Use smoke tester and adjust air for a minimum smoke (not to exceed #1) with a minimum excess air. Make final check using suitable instrumentation to obtain CO₂ of 11.5% to 12%. These settings will assure a safe and efficient

operating condition. If flame appears stringy instead of solid fire, try another nozzle of the same type.

2. The plate setting number has been factory preset to obtain an initial CO₂ range of 11.0 – 11.5 % at burner start-up. Adjusting head/air plate forward (the pointer will move towards “0” scale number) reduces excess air and increases % CO₂. Adjusting head/air plate rearwards (the pointer will move towards “5” scale number) increases excess air and reduces % CO₂. See Figure 45.
3. Use 5/16” nut driver or flat blade screwdriver to turn the adjustment screw to achieve desired head/air setting number. Tighten the splined nut and the lower acorn nut, once desired head/air setting has been made.
4. TURN "OFF" BURNER
 - a. Open service switch
 - b. Remove pressure gauge.
 - c. Re-install vent/bleed fitting and tighten securely.
 - d. Start burner again.

WARNING

Do not loosen or remove any oil line fittings while burner is operating.

5. FLAME FAILURE

The boiler controls operate the burner automatically. If for unknown reasons the burner ceases to operate and the reset button on the primary control has tripped, the burner has experienced ignition failure.

WARNING

Do not attempt to start the burner when excess oil has accumulated, when the unit is full of vapor, or when the combustion chamber is very hot.

K. CHECK FOR CLEAN CUT OFF OF BURNER.

1. AIR IN THE OIL LINE between fuel unit and nozzle will compress when burner is on and will expand when burner stops, causing oil to squirt from nozzle at low pressure as the burner slows down and causing nozzle to drip after burner stops. Usually, cycling the burner operation about 5 to 10 times will eliminate air from the oil line.
2. IF NOZZLE CONTINUES TO DRIP, repeat Paragraph K, No. 1. If this does not stop the dripping, remove cut-off valve and seat, and wipe both with a clean cloth until clean, then replace and readjust oil pressure. If dripping or after burn persist replace fuel pump.

L. TEST CONTROLS.

1. Check thermostat operation. Raise and lower thermostat setting as required to start and stop burner.

WARNING

Before installation of the boiler is considered complete, the operation of all boiler controls must be checked, particularly the primary control and high limit control.

2. VERIFY PRIMARY CONTROL FEATURES using procedures outlined in Instructions furnished with control or instructions as follows:
 - a. FEATURES AND CONTROLS
 - i. The R7184 is a microprocessor-based control. The indicator light provides diagnostic information for lockout, recycling and patented cad cell status. There is a manual reset button to exit the Lockout Mode and enter the Idle Mode (see Figure 47).
 - ii. Pump Priming Cycle: To facilitate purging air from the oil lines and filters, the R7184 can be placed in a purge routine by pressing and releasing the reset button during the safety check, delayed valve-on, ignition or carry-over periods.
 - iii. Limited Recycle: This feature limits the number of recycle trials (for each call for heat) to a maximum of three trials. If the flame is lost three times and does not successfully satisfy a call for heat, the R7184 locks out.
 - iv. Limited Reset (Restricted Mode): In order to limit the accumulation of unburned oil in the combustion area, the control can only be reset three times. The reset count returns to zero each time a call for heat is successfully completed.
 - v. T-T Jumper: Select models have pre-installed T-T jumper. Do not remove jumper. (See Figure 47).
 - vi. Diagnostic LED: The indicator light on oil primary control provides lockout, recycle and cad cell indications as follows:

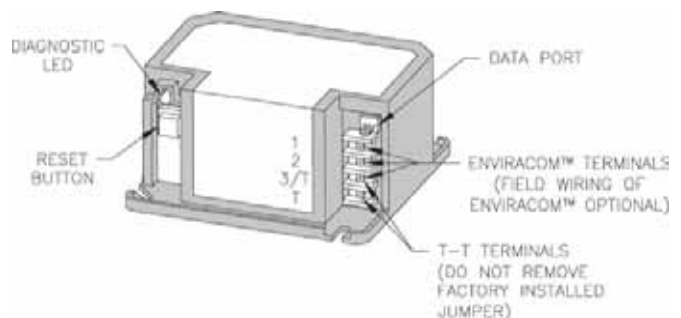

Figure 47: R7184 Terminals, LED and Reset Button

- Flashing at 1 Hz (½ second on, ½ second off): system is locked out or in Restricted Mode.
 - Flashing at ¼ Hz (2 seconds on, 2 seconds off): control is in Recycle Mode.
 - On: cad cell is sensing flame.
 - Off: cad cell is not sensing flame.
- vii. Cad Cell Resistance Check: For proper operation it is important that the cad cell resistance is below 1600 ohms. During a normal call for heat, once the control has entered the Run Mode, press and release the reset button. Indicator light will flash 1 to 4 flashes. See Table 11 for equivalent cad cell resistance.

TABLE 11: CAD CELL RESISTANCE WHEN SENSING FLAME

Flashes	Cad Cell Resistance in ohms
1	Less than 400
2	More than 400 and less than 800
3	More than 800 and less than 1600
4	More than 1600 and less than 5000

b. CHECK OIL PRIMARY CONTROL

CAUTION

Due to the potential hazard of line voltage, only a trained, experienced service technician should perform the following safety checks.

This control contains no field-serviceable parts. Do not attempt to take it apart. Replace entire control if operation is not as described.

- i. Preliminary Steps
- Check wiring connections and power supply.
 - Make sure power is on to the controls.
 - Make sure limit control is closed.
 - Check contacts between ignitor and the electrodes.
 - Check the oil pump pressure.
 - Check the piping to the oil tank.
 - Check the oil nozzle, oil supply and oil filter.
- ii. Check Safety Features
- Safe Start:
- Place a jumper across cad cell terminals.
 - Follow procedure to turn on burner.

Burner must not start, indicator light turns on and control remains in Idle Mode.

- Remove jumper.
- iii. Simulate Ignition or Flame Failure:
- Follow procedure to turn on burner.
 - Close hand valve in oil supply line.
 - Failure occurs, device enters Recycle Mode. Indicator light flashes at ¼ Hz rate (2 seconds on, 2 seconds off).
 - Device tries to restart system after approximately 60 seconds.
 - After third Recycle Mode trial, safety switch locks out within safety switch timing indicated on label and control enters Restricted Mode. Indicator light flashes at 1 Hz rate (½ second on, ½ second off). Ignition and motor stop and oil valves closes.
- iv. Cad Cell Check: See Figure 48.

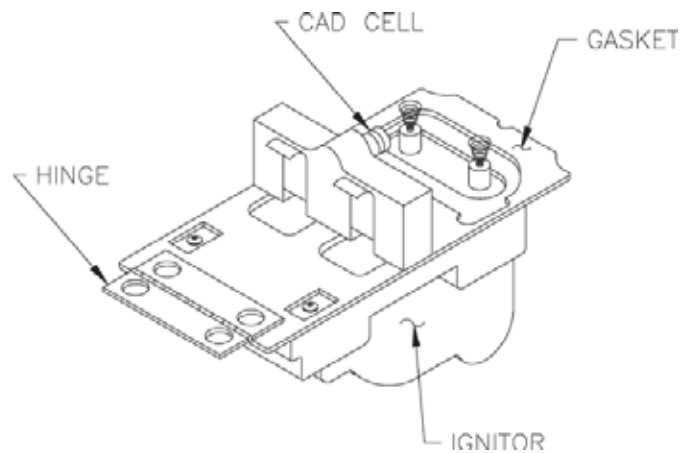

Figure 48: Cad Cell Location

- Perform cad cell resistance check as outlined in control feature. If resistance is below 1600 OHMS and burner runs beyond safety cut-out time, cad cell is good.
- If safety switch shuts down burner and resistance is above 1600 OHMS, open line switch to boiler. Access cad cell under ignitor, clean face of cad cell and see that cell is securely in socket. Check gasket around perimeter of ignitor lid for proper seal. If gasket is missing or damaged, replace gasket. Room light can effect cad cell resistance. Reset safety switch.
- Close line switch to boiler. If burner starts and runs beyond safety switch cut-off time, cell is good. If not, install new cell.

- v. Power Failure Check: After Flame is established, turn the power off to the control/ burner. The burner should shut down safely. When power is restored a normal ignition sequence should be started.

3. WARNING — Check High Limit Control —

Jumper Thermostat Terminals. Allow burner to operate until shut-down by limit. Installation is not considered complete until this check has been made.

WARNING

Jumper must be removed after this check.

4. CHECK LOW WATER CUT - OFF CONTROL

IMPORTANT

Do not run boiler unattended until the following procedure is completed.

Hydrolevel 1150 probe low water cut-off operational test procedure:

- a. Before raising the water level above the Model 1150, turn on power to the boiler and set the thermostat to call for heat. Both the green

"POWER" LED and amber "LOW WATER" LED should illuminate. The burner should not fire. **IMPORTANT:** If the burner fires with no water at the probe, immediately shut down power to the boiler and refer to the Trouble Shooting instructions in manufacturer's literature provided with the control.

- b. Proceed to fill the boiler with water. When water reaches the LWCO position, the burner should fire. If the burner does not fire, refer to the Trouble Shooting instructions in manufacturer's literature provided with the control.
- c. Turn off the power to the boiler and finish filling the system. Lower the thermostat to desired room temperature setting.
- d. Before leaving the job, power up the system and push the TEST button on the Model 1150 to simulate a low water condition. The amber "LOW WATER" LED should illuminate and the burner should shut down.

M. IF CONTROLS DO NOT MEET REQUIREMENTS outlined in Paragraph L., replace control and repeat checkout procedures.

Important Product Safety Information **Refractory Ceramic Fiber Product**

Warning:

The Repair Parts list designates parts that contain refractory ceramic fibers (RCF). RCF has been classified as a possible human carcinogen. When exposed to temperatures about 1805°F, such as during direct flame contact, RCF changes into crystalline silica, a known carcinogen. When disturbed as a result of servicing or repair, these substances become airborne and, if inhaled, may be hazardous to your health.

AVOID Breathing Fiber Particulates and Dust

Precautionary Measures:

Do not remove or replace RCF parts or attempt any service or repair work involving RCF without wearing the following protective gear:

1. A National Institute for Occupational Safety and Health (NIOSH) approved respirator
 2. Long sleeved, loose fitting clothing
 3. Gloves
 4. Eye Protection
- Take steps to assure adequate ventilation.
 - Wash all exposed body areas gently with soap and water after contact.
 - Wash work clothes separately from other laundry and rinse washing machine after use to avoid contaminating other clothes.
 - Discard used RCF components by sealing in an airtight plastic bag. RCF and crystalline silica are not classified as hazardous wastes in the United States and Canada.

First Aid Procedures:

- If contact with eyes: Flush with water for at least 15 minutes. Seek immediate medical attention if irritation persists.
- If contact with skin: Wash affected area gently with soap and water. Seek immediate medical attention if irritation persists.
- If breathing difficulty develops: Leave the area and move to a location with clean fresh air. Seek immediate medical attention if breathing difficulties persist.
- Ingestion: Do not induce vomiting. Drink plenty of water. Seek immediate medical attention.

SECTION XI: MAINTENANCE AND SERVICE INSTRUCTIONS

A. MAINTENANCE OF LOW WATER CUT-OFF DEVICES (when installed)

See Section XV Appendix for LWCO Installation Instructions.

WARNING

Probe type low water cut-off devices require annual inspection and maintenance.

1. PROBE TYPE LOW WATER CUT-OFF

Although these devices are solid state in their operation, the probe is exposed to possible contamination in the boiler water and subject to fouling.

Provisions have been made on the supply manifold on the boiler. Sometimes the LWCO can be found in the primary loop of the boiler system. Ideally, shut off valves have been installed between the loop containing the LWCO and the rest of the system, to minimize the amount of system draining.

It is important to physically remove the probe from the LWCO tapping annually and inspect that probe for accumulation of scale or sediment.

Follow these steps to inspect, clean and/or replace the probe:

- a. Turn off electric service to the boiler.
- b. Drain boiler water to a level below the tapping for the probe.
- c. Disconnect wiring connections between the low water cut-off control and the probe.
- d. Remove the low water cut-off control from the probe.

DANGER

Assure that the boiler is at zero pressure before removing the LWCO probe. Do not rely on the pressure gauge to indicate that the boiler is at zero pressure. Open the safety valve to relieve all internal pressure prior to proceeding. Safety valve discharge piping must be piped such that the potential for burns is eliminated.

- e. Unscrew the probe from the LWCO tapping.
- f. Inspect that portion of the probe that is exposed to the water for a scale or sediment buildup.
- g. Light deposits may be removed by wiping the probe with a damp cloth. Wiping the probe with a cloth soaked in vinegar will remove more

tenacious lime deposits. The most stubborn deposits may be removed from the probe by using a diluted amount, 3 parts of water to 1 part of phosphoric acid (H_2PO_4).

CAUTION

Exercise caution when handling phosphoric acid and follow the instruction label on its container.

- h. Clean the pipe threads of the probe to remove old, hardened pipe dope and other foreign matter.
- i. Apply a moderate amount of good quality pipe dope to the pipe threads on the probe, leaving the two end threads bare. Do not use PTFE (Teflon) tape.
- j. Screw the probe into the LWCO tapping.
- k. Mount the low water cut-off control on the probe.
 - l. Reconnect the control to probe wiring.
 - m. Fill the system with water.
 - n. Add boiler water treatment compound as needed (refer to Paragraph B.).
 - o. Restore electric service to the boiler.
 - p. Fire burner to bring the water in the boiler to a boil to drive off free oxygen.
 - q. **WARNING — BEFORE RETURNING BOILER TO SERVICE:** Follow the low water cut-off check out procedure in Section X, Paragraph I, No. 4.

B. BOILER AND SYSTEM CLEANING INSTRUCTIONS FOR TROUBLE FREE OPERATION

1. *Filling of Boiler and System — General* — In a hot water heating system, the boiler and entire system (other than the expansion tank) must be full of water for satisfactory operation. Water should be added to the system until the boiler pressure gauge registers 12 psi. To insure that the system is full, water should come out of all air vents when opened.
2. *Boiling Out of Boiler and System.* The oil and grease which accumulate in a new hot water boiler can be washed out in the following manner.
 - a. Ideally, shut off valves have been installed between the boiler return manifold and the rest of the system, to minimize the amount of system draining.
 - b. Drain the boiler to a level below the relief valve tapping.

DANGER

Assure that the boiler is at zero pressure before removing the relief valve. Open the safety valve to relieve all internal pressure prior to proceeding. Safety valve discharge piping must be piped such that the potential for burns is eliminated.

- c. Remove relief valve using extreme care to avoid damaging it.
 - d. Add an appropriate amount of recommended boiler compound.
 - e. Replace relief valve.
 - f. Fill the entire system with water.
 - g. Start firing the boiler.
 - h. Circulate the water through the entire system.
 - i. Vent the system, including the radiation.
 - j. Allow boiler water to reach operating temperature, if possible.
 - k. Continue to circulate the water for a few hours.
 - l. Stop firing the boiler.
 - m. Drain the system in a manner and to a location that hot water can be discharged with safety.
 - n. Remove plugs from all available returns and wash the water side of the boiler as thoroughly as possible, using a high-pressure water stream.
 - o. Refill the system with fresh water.
3. Add appropriate boiler water treatment compounds as recommended by your qualified water treatment company.
4. *Make pH or Alkalinity Test.*

After boiler and system have been cleaned and refilled as previously described, test the pH of the water in the system. This can easily be done by drawing a small sample of boiler water and testing with hydrion paper which is used in the same manner as litmus paper, except it gives specific readings. A color chart on the side of the small hydrion dispenser gives the reading pH. Hydrion paper is inexpensive and obtainable from any chemical supply house or through your local druggist. The pH should be higher than 7 but lower

than 11. Add appropriate water treatment chemicals, if necessary, to bring the pH within the specified range. With this lower level of protection, care must be exercised to eliminate all of the free oxygen in the system.

5. Boiler is now ready to be put into service.

C. FREQUENT WATER ADDITION

Although unusual for a water boiler, frequent water additions are a sign of a leaky system. Excessive amounts of make up water supplied to the boiler can significantly shorten the life of the boiler. The amount of water varies with the contamination level of the water. Repair the leak and consult with your water treatment specialist for recommendations.

D. ATTENTION TO BOILER WHILE NOT IN OPERATION.

NOTICE

If boiler is not used during winter time, it must be fully drained to prevent freeze damage.

1. Spray inside surfaces with light lubricating or crankcase oil using gun with extended stem so as to reach all corners.
2. Always keep the manual fuel supply valve shut off if the burner is shut down for an extended period of time.
3. To recondition the heating system in the fall season after a prolonged shut down, follow the instructions outlined in Section X, Paragraphs A through M.

WARNING

This boiler contains controls which may cause the boiler to shut down and not restart without service. If damage due to frozen pipes is a possibility, the heating system should not be left unattended in cold weather; or appropriate safeguards and alarms should be installed on the heating system to prevent damage if the boiler is inoperative.

SECTION XII: BOILER CLEANING

WARNING

All boiler cleaning must be completed with burner service switch turned off. Boilers equipped with burner swing door have a potential hazard which can cause severe property damage, personal injury or loss of life if ignored. Before opening swing door, turn off service switch to boiler to prevent accidental firing of burner outside the combustion chamber. Disconnect the burner plug from the receptacle in the front jacket. Be sure to tighten swing door fastener completely when service is completed.

A. CLEAN THE FLUEWAYS (See Figure 49).

1. For access to the combustion chamber remove the two (2) 3/8" - 16 cap screws. If boiler is equipped with flexible fuel line(s), swing door open.
2. Remove the two smoke box clean-out covers from the rear smoke box by removing the four 5/16"-18 hex head bolts. It is NOT necessary to remove the vent connector from the smoke box to clean boiler. If necessary, remove the vent connector if there is evidence of heavy soot accumulation in the boiler or to inspect base of chimney for condensate or accumulation of debris.
3. Remove the baffles (if installed) from the flue passages. There is a pair of baffles in each boiler. The baffles are installed in the 3rd pass (two outer flueways) on the MPO84, and in the 2nd pass (two inner flue ways) on the MPO147, MPO189 and MPO231.
4. Clean the 3rd Pass – Insert a 2" dia. x 42" long wire or fiber bristle brush into each of the two 3rd passes. Using long strokes push the brush all the way through the boiler until the brush has exited the smoke box opening. Pull the brush all the way forward until it has exited the front of the boiler. Continue this operation for the entire height of the flue way until clean. Repeat the operation for the other 3rd pass flue way.
5. Clean the 2nd Pass - Insert a 2" dia. x 42" long wire or fiber bristle brush into each of the two 2nd passes. Using long strokes push the brush all the way through the boiler until the brush hits the back wall of the reversing chamber. Pull the brush all the way forward until it has exited the front of the boiler. Continue this operation for the entire height of the flue way until clean. Repeat the operation for the other 2nd pass flue way.
6. Vacuum the loose debris in the bottom of the combustion chamber and smoke box.

B. CLEAN THE COMBUSTION CHAMBER

– Use a wire or fiber bristle brush to clean the surfaces of the combustion chamber. Vacuum all of the loose debris in the bottom of the combustion chamber.

C. AFTER CLEANING, vacuum all remaining debris as necessary. Inspect burner swing door insulation, and rope gasket for signs of damage. If damaged, replace as needed.

D. REASSEMBLE BOILER.

CAUTION

Do not start the burner unless the burner swing door and canopy cover plates are secured in place.

1. Insert the baffles (if originally installed) into the correct flue way. The baffles are installed in the 3rd pass (two outer flueways) on the MPO84, and in the 2nd pass (two inner flue ways) on the MPO147, MPO189 and MPO231.
2. Attach the smoke box clean-out covers onto the rear of the boiler. Verify that the rope gasket is in good working order before assembly. Replace rope gasket if necessary. Use the 3/8" hardware originally removed. Do not over tighten. They should be snug but not bottomed out.

NOTICE

When securing burner swing door make sure door is drawn-in equally on both sides.

Tighten swing door hardware to provide adequate seal to rope gasket around perimeter of door.

Use an alternating tightening method from right side to left side cap screw to pull door tight equally.

NOTICE

Do not overtighten. The rope gasket will provide sufficient seal when the door is snugged into place.

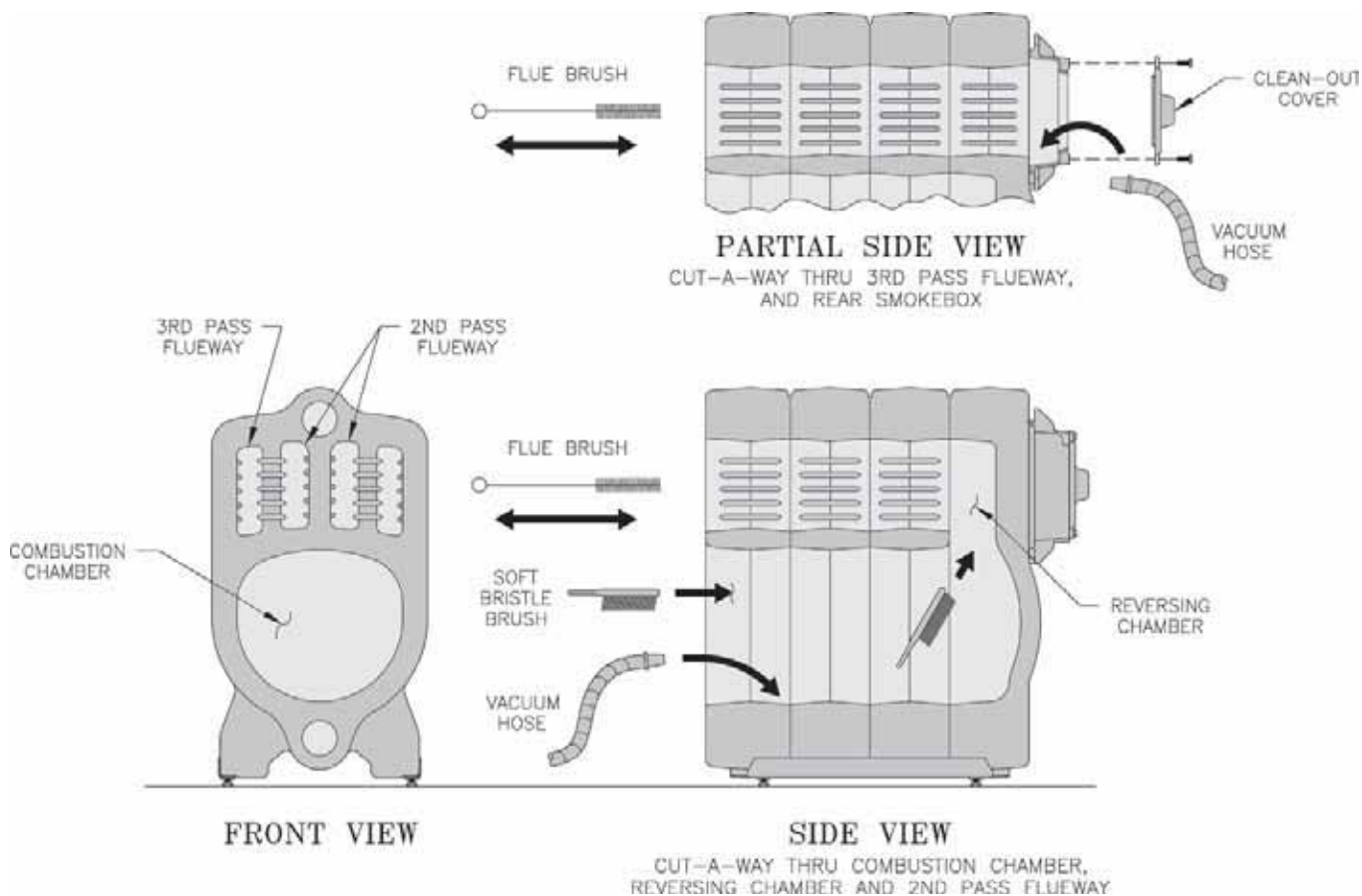

Figure 49: Cleaning of Boiler Flueways

WARNING

The boiler must be connected to an approved chimney in good condition. Serious property damage could result if the boiler is connected to a dirty or inadequate chimney. The interior of the chimney flue must be inspected and cleaned before the start of the heating season and should be inspected periodically throughout the heating season for any obstructions. A clean and unobstructed chimney flue is necessary to allow noxious fumes that could cause injury or loss of life to vent safely and will contribute toward maintaining the boiler's efficiency.

SECTION XIII: TROUBLE SHOOTING

A. COMBUSTION

1. **NOZZLES** — Although the nozzle is a relatively inexpensive device, its function is critical to the successful operation of the oil burner. The selection of the nozzle supplied with the MPO boiler is the result of extensive testing to obtain the best flame shape and efficient combustion. Other brands of the same spray angle and spray pattern may be used but may not perform at the expected level of CO₂ and smoke. Nozzles are delicate and should be protected from dirt and abuse. Nozzles are mass-produced and can vary from sample to sample. For all of those reasons a spare nozzle is a desirable item for a serviceman to have.
2. **FLAME SHAPE** — Looking into the combustion chamber through the observation port, the flame should appear straight with no sparklers rolling up toward the crown of the chamber. If the flame drags to the right or left, sends sparklers upward or makes wet spots on the chamber walls, the nozzle should be replaced. If the condition persists look for fuel leaks, air leaks, water or dirt in the fuel as described above.
3. **FUEL LEAKS** — Any fuel leak between the pump and the nozzle will be detrimental to good combustion results. Look for wet surfaces in the air tube, under the ignitor, and around the air inlet. Any such leaks should be repaired as they may cause erratic burning of the fuel and in the extreme case may become a fire hazard.
4. **AIR LEAKS** — Any such leaks should be repaired, as they may cause erratic burning of the fuel and in extreme cases may become a fire hazard.
5. **GASKET LEAKS** — If 11.5 to 12.5% CO₂ with a #1 smoke cannot be obtained in the breeching, look for air leaks around the burner mounting gasket, observation door, and canopy gasket. Such air leaks will cause a lower CO₂ reading in the breeching. The smaller the firing rate the greater effect an air leak can have on CO₂ readings.
6. **DIRT** — A fuel filter is a good investment. Accidental accumulation of dirt in the fuel system can clog the nozzle or nozzle strainer and produce a poor spray pattern from the nozzle. The smaller the firing rate, the smaller the slots become in the nozzle and the more prone to plugging it becomes with the same amount of dirt.
7. **WATER** — Water in the fuel in large amounts will stall the fuel pump. Water in the fuel in smaller amounts will cause excessive wear on the pump, but more importantly water doesn't burn. It chills the flame and causes smoke and unburned fuel to pass out of the combustion chamber and clog the flueways of the boiler.
8. **COLD OIL** — If the oil temperature approaching the fuel pump is 40°F or lower, poor combustion or delayed ignition may result. Cold oil is harder to atomize at the nozzle. Thus, the spray droplets get larger and the flame shape gets longer. An outside fuel tank that is above grade or has fuel lines in a shallow bury is a good candidate for cold oil. The best solution is to bury the tank and lines deep enough to keep the oil above 40°F.
9. **HIGH ALTITUDE INSTALLATIONS** — Air openings must be increased at higher altitudes. Use instruments and set for 11.5 to 12.5% CO₂.
10. **START-UP NOISE** — Late ignition is the cause of start-up noises. If it occurs recheck for electrode settings, flame shape, air or water in the fuel lines.
11. **SHUT DOWN NOISE** — If the flame runs out of air before it runs out of fuel, an after burn with noise may occur. That may be the result of a faulty cut-off valve in the fuel pump, or it may be air trapped in the nozzle line. It may take several firing cycles for that air to be fully vented through the nozzle. Water in the fuel or poor flame shape can also cause shut down noises.

NOTICE

CHECK TEST PROCEDURE. A very good test for isolating fuel side problems is to disconnect the fuel system and with a 24" length of tubing, fire out of an auxiliary five gallon pail of clean, fresh, warm #2 oil from another source. If the burner runs successfully when drawing out of the auxiliary pail then the problem is isolated to the fuel or fuel lines being used on the jobsite.

B. OIL PRIMARY CONTROL

1. Burner (control) will not come on.
 - a. No power to control.
 - b. Control is in lockout or restricted mode. Press reset button for one (1) second to exit lockout. If control has recycled three times within the same call for heat, it will enter into restricted mode. To reset from restricted mode, refer to Section X, Paragraph L, No. 2 for details.
 - c. CAD cell seeing light.
 - d. CAD assembly defective.
 - e. Control motor relay is stuck closed (see note below).
2. Burner (control) will light, then shut down after a short time, then restart after one (1) minute.
 - a. CAD cell is defective.
 - b. Air leaking into oil line causing flame out.
 - c. Defective nozzle causing flame to be erratic.

- d. Excessive airflow or draft causing flame to leave burner head.
 - e. Excessive back pressure causing flame to be erratic.
3. Control locks out after Trial For Ignition (TFI).
- a. No oil to burner.
 - b. Shorted electrodes.
 - c. Nozzle clogged.
 - d. Airflow too high.
 - e. Ignitor module defective.
 - f. CAD cell defective.
 - g. Oil valve stuck open or closed.

Note: The Safety Monitoring Circuit (SMC) is designed to provide lockout in the event of a stuck or welded motor relay.

NOTICE

If flame is not established within 15 seconds of oil valve actuation (known as Trial For Ignition [TFI]) lockout will occur. Lockout is indicated by a red LED solid-on located on the oil primary control.

Latch-up will occur if the control locks-out three (3) times during a call for heat. This is indicated by steady-on red and amber LED's.

TABLE 12: TROUBLE SHOOTING GUIDE

System Condition	Diagnostic Condition	Check	Action
Boiler is cold, house is cold.	Display is OFF.	120 Vac System power.	Turn system power on.
	Display is ON.	24 Vac T-T	No 24 V; replace control.
		24 V present; disconnect thermostat, short T-T.	Boiler starts, check wiring and thermostat.
		120 Vac at B1-B2	<ul style="list-style-type: none"> • If no, replace control. • If yes, check burner and wiring.
		Refer to Err on display.	-----
Boiler is hot, house is cold.	Display is ON.	120 Vac at C1-C2	<ul style="list-style-type: none"> • 120 Vac at C1-C2, check wiring to pump. • Wiring OK, is pump running? <ul style="list-style-type: none"> • If not, replace the pump. • If pump is running, check for trapped air or closed zone valves
		Boiler below the Low Limit temperature, wait for boiler to go above Low Limit temperature.	-----
		Boiler above LL? If yes, check for 120 Vac between ZC and L2.	<ul style="list-style-type: none"> • If no 120 Vac, replace control. • If yes, check zone relays, circulators and wiring.

SECTION XIV: REPAIR PARTS

All MPO® Boiler Repair Parts may be obtained through your local Burnham Wholesale distributor. Should you require assistance in locating a Burnham Distributor in your area, or have questions regarding the availability of Burnham products or repair parts, please contact Burnham Customer Service at (717) 481-8400 or Fax (717) 481-8408.

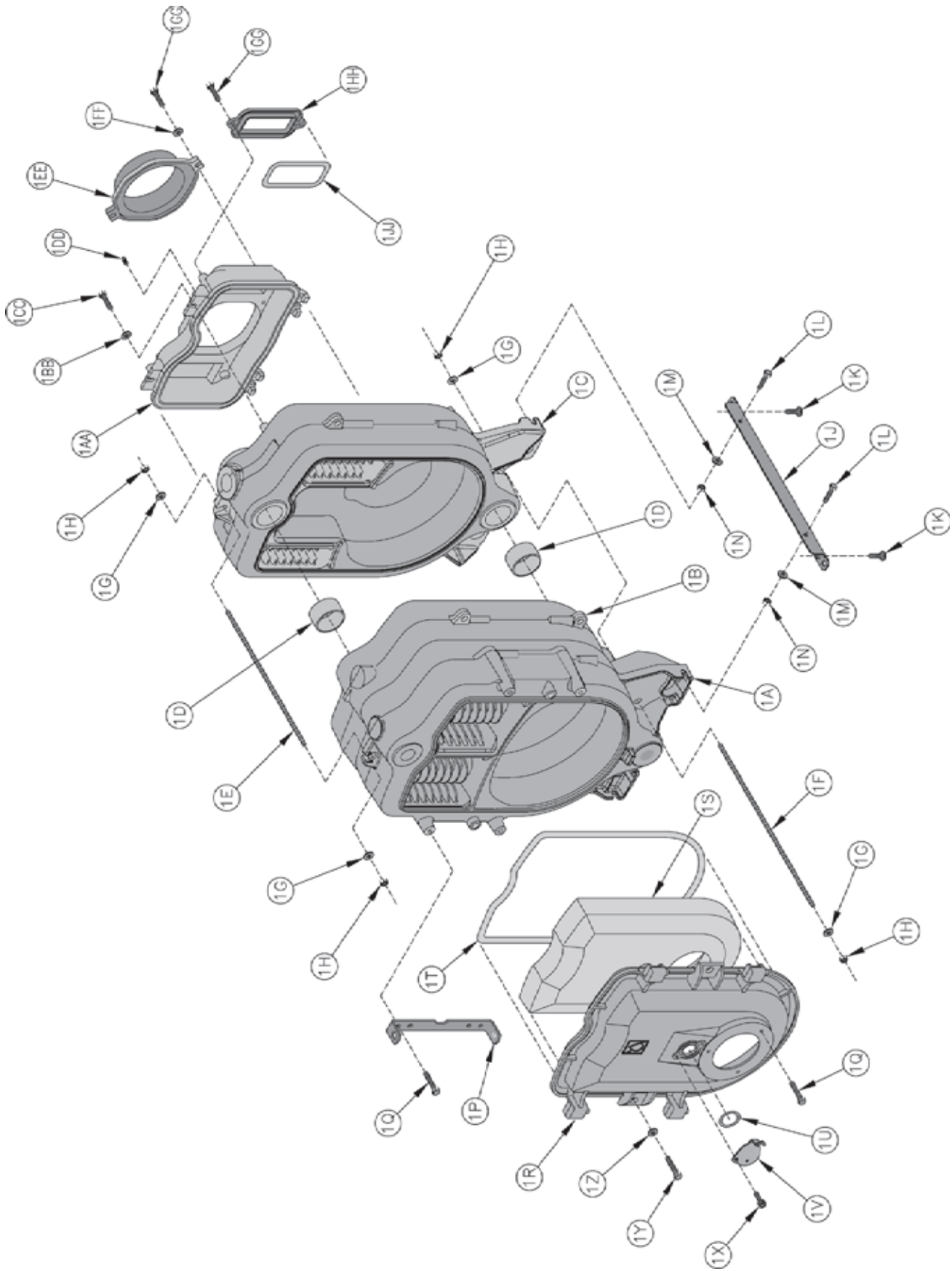

Bare Boiler Assembly

Item No.	Description	Part No.	MPO84	MPO115	MPO147	MPO189	MPO231	
1. BARE BOILER ASSEMBLY								
1A	Front Section, Machined	100060-01	1	1	1	1	1	
1B	Center Section, Machined	100061-01	---	---	1	2	3	
1C	Rear Section, Machined	100062-01	1	1	1	1	1	
1D	Slip Nipple, 22-B Steel	806600375	2	2	4	6	8	
1E	Upper Tie Rod, 3/8"-16 x 10" Lg.	80861071	1	1	---	---	---	
	Upper Tie Rod, 3/8"-16 x 16" Lg.	80861075	---	---	1	---	---	
	Upper Tie Rod, 3/8"-16 x 21-1/2" Lg.	80861033	---	---	---	1	---	
	Upper Tie Rod, 3/8"-16 x 27-1/2" Lg.	80861014	---	---	---	---	1	
1F	Lower Tie Rod, 3/8"-16 x 7-3/4" Lg.	80861072	1	1	---	---	---	
	Lower Tie Rod, 3/8"-16 x 15" Lg.	80861016	---	---	1	---	---	
	Lower Tie Rod, 3/8"-16 x 20-3/4" Lg.	80861012	---	---	---	1	---	
	Lower Tie Rod, 3/8"-16 x 27" Lg.	80861018	---	---	---	---	1	
1G	3/8" Flat Washer, USS, Plain	80860600	4	4	4	4	4	
1H	3/8" -16 Heavy Hex Nut, Plain	80860400	4	4	4	4	4	
1J	Spanner Bar w/Threaded Inserts, 1-1/4" x 1-1/2" x 14-3/8" Lg.	100012-01	2	2	---	---	---	
	Spanner Bar w/Threaded Inserts, 1-1/4" x 1-1/2" x 20-3/8" Lg.	100012-02	---	---	2	---	---	
	Spanner Bar w/Threaded Inserts, 1-1/4" x 1-1/2" x 26-3/8" Lg.	100012-03	---	---	---	2	---	
	Spanner Bar w/Threaded Inserts, 1-1/4" x 1-1/2" x 32-3/8" Lg.	100012-04	---	---	---	---	2	
1K	Carriage Bolt, 3/8"-16 x 1-1/4" Lg., Plated	100215-01	4	4	4	4	4	
1L	Cap Screw, 5/16"-18 x 7/8" Lg., Plated	80861371	4	4	4	4	4	
1M	Flat Washer, 5/16" USS, Plated	80860611	4	4	4	4	4	
1N	Hex Nut, 5/16-18, Serrated Flange, Plated	80860443	4	4	4	4	4	
1P	Hinge Bracket	100014-01	1	1	1	1	1	
1Q	5/16"-18 x 3/4" Lg. Cap Screw, Plated	Hinge Bracket	80861340	2	2	2	2	2
		Mount Burner		3	3	3	3	3
1R	Cast Iron Burner Swing Door (Only)	100071-01	1	1	1	1	1	

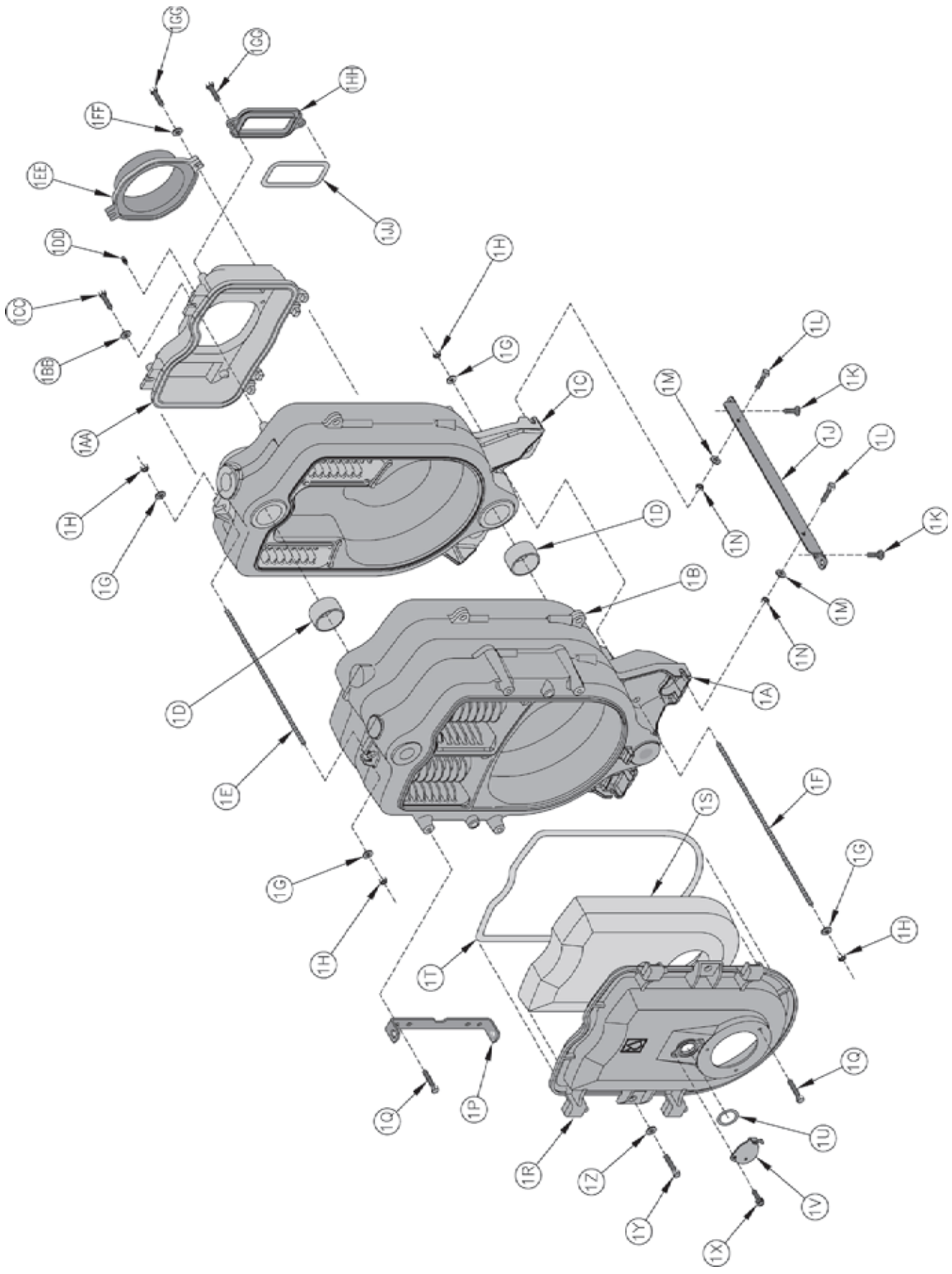

Bare Boiler Assembly

Item No.	Description	Part No.	MPO84	MPO115	MPO147	MPO189	MPO231	
1. BARE BOILER ASSEMBLY (Continued)								
1S	Burner Swing Door Insulation (Less Pockets)	100039-01	1	1	1	1	---	
	Burner Swing Door Insulation (With Pockets)	100039-02	---	---	---	---	1	
1T	5/8" Dia. Rope Gasket - Burner Swing Door	100097-01	1	1	1	1	1	
1U	1/8" Dia. Rope Gasket - Observation Port	100096-01	1	1	1	1	1	
1V	Observation Port Cover	100074-01	1	1	1	1	1	
1X	5/16"-18 x 5/8" Lg. Socket Head Cap Screw, Plated	100050-01	2	2	2	2	2	
1Y	3/8"-16 x 1-3/4" Lg. Tap Bolt, Plated	100102-01	2	2	2	2	2	
1Z	3/8" Flat Washer, USS, Plated	80860618	2	2	2	2	2	
1AA	Smokebox	100021-01	1	1	1	1	1	
1BB	5/16" Flat Washer, USS, Plain	80860601	4	4	4	4	4	
1CC	5/16"-18 x 7/8" Lg. Cap Screw, Plain	80861340	4	4	4	4	4	
1DD	1/4" NPT Pipe Plug, Square Head, Brass	806603542	1	1	1	1	1	
1EE	Smokebox Collar	5" Dia.	100092-01	1	1	---	---	---
		6" Dia.	100093-01	---	---	1	1	---
		7" Dia.	100094-01	---	---	---	---	1
1FF	5/16" Flat Washer, USS, Plated	80860611	2	2	2	2	2	
1GG	5/16"-18 x 7/8" Lg. Cap Screw, Plated	80861371	6	6	6	6	6	
1HH	Cast Iron Clean-Cut Cover (only)	100104-01	2	2	2	2	2	
1JJ	1/2" Dia. Rope Gasket - Clean-Cut Cover	100095-01	2	2	2	2	2	

Item No.	Description	Part No.	MPO84	MPO115	MPO147	MPO189	MPO231
2. JACKET ASSEMBLY							
2A	Jacket Front Panel Assembly w/Insulation	100007-01	1	1	1	1	1
2B	Power Outlet Receptacle, Heyco #0937	8136522	1	1	1	1	1
2C	#8 x 1/2" Type AB, Phillips Truss Head w/Shoulder, Sheet Metal Screw, Plated	100038-01	8	8	8	8	8
2D	Jacket Rear Panel Assembly w/Insulation	100008-01	1	1	1	1	1
2E	Snap Bushing, Heyco #2043	8136048	1	1	1	1	1
2F	Internal Junction Box Assembly	100043-01	1	1	1	1	1
2G	Snap bushing, Heyco #2073	100057-01	1	1	1	1	1
2H	5/16" -18 x 3" Lg. Tap End Stud, Plain	100046-01	2	2	2	2	2
2J	5/8" O.D. x 2-5/32" Lg. Jacket Spacer	100035-01	2	2	2	2	2
2K	5/16" -18 Acorn Nut, Plated	100047-01	2	2	2	2	2
2L	3" Thick Fiberglass Insulation Wrapper For:						
	2 Section Cast Iron, Block Assembly	100016-01	1	1	---	---	---
	3 Section Cast Iron, Block Assembly	100016-02	---	---	1	---	---
	4 Section Cast Iron, Block Assembly	100016-03	---	---	---	1	---
	5 Section Cast Iron, Block Assembly	100016-04	---	---	---	---	1
2M	Jacket Side Panel Assembly (No Insulation Required)						
	2 Section Boiler	100009-01	1	1	---	---	---
	3 Section Boiler	100009-02	---	---	1	---	---
	4 Section Boiler	100009-03	---	---	---	1	---
	5 Section Boiler	100009-04	---	---	---	---	1
2N	Jacket Top Panel Assembly (No Insulation Required)						
	2 Section Boiler	100010-01	1	1	---	---	---
	3 Section Boiler	100010-02	---	---	1	---	---
	4 Section Boiler	100010-03	---	---	---	1	---
	5 Section Boiler	100010-04	---	---	---	---	1
2P	Snap Bushing, Heyco #2407	100056-01	1	1	1	1	1
2Q	Jacket Top Rear Panel Assembly (No Insulation Required)	100011-01	1	1	1	1	1
2R	Beckett Burner Plastic Enclosure Backer Plate	102233-01	1	1	1	1	1
2S	Beckett Burner Plastic Enclosure Cover	102232-01	1	1	1	1	1
2T	Beckett Burner Plastic Enclosure Name Plate	102231-01	1	1	1	1	1

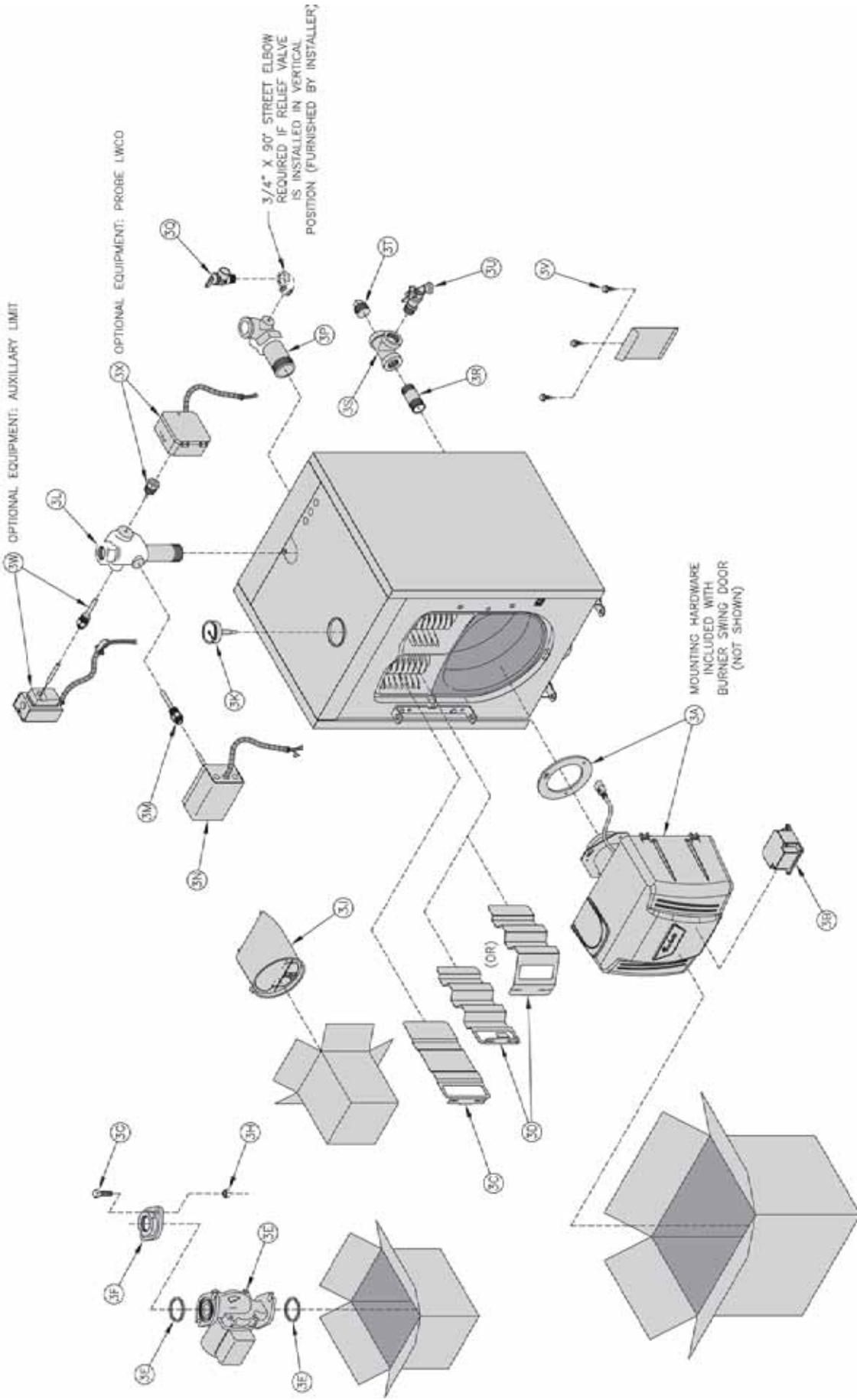

MPO84 Thru MPO231 Water Boilers - Trim and Controls

Item No.	Description	Part No.	MPO84	MPO115	MPO147	MPO189	MPO231
3. MPO84 Thru MPO231 WATER BOILERS - TRIM AND CONTROLS							
3A	Beckett AFG Oil Burner w/Gasket for: Natural Draft						
	MPO84 Spec No. BCB7702	100052-01	1	---	---	---	---
	MPO115 Spec No. BCB7707	102065-01	---	1	---	---	---
	MPO147 Spec No. BCB7703	100053-01	---	---	1	---	---
	MPO189 Spec No. BCB7704	100054-01	---	---	---	1	---
	MPO231 Spec No. BCB7705	100055-01	---	---	---	---	1
	Beckett NX Oil burner w/Gasket for: Direct Vent						
	Spec No. BCB7903	100240-02	---	---	1	---	---
	Spec No. BCB7904	100240-03	---	---	---	1	---
	Spec No. BCB7905	100240-04	---	---	---	---	1
	---Riello 40 Oil Burner w/Gasket for: Natural Draft						
	MPO147 Spec No. C8512478	100831-01	---	---	1	---	---
	MPO189 Spec No. C8512487	101762-01	---	---	---	1	---
	MPO231 Spec No. C8512488	101763-01	---	---	---	---	1
	(Note: See Pages 78 and 79 for Beckett Burner Parts Breakdown)						
3B	Oil Primary Control, Honeywell R7184P1080	80160849	1	1	1	1	1
3C	Stainless Steel Third Pass Flueway Baffle	100081-01	2	2	---	---	---
3D	Stainless Steel Second Pass Flueway Baffle	100042-01	---	---	2	2	2
		102066-01	---	2	---	---	---
3E	Circulator w/Gaskets	Taco 007	8056170	1	1	1	1
		Bell & Gossett NRF22	8056174				
		Grundfos UP15-42F	8056173				
3F	Circulator Flange, 1-1/2" NPT	806602014	2	2	2	2	2
3G	Cap Screw, Hex Head, 7/16" -14 x 1-1/2" Lg.	80861301	4	4	4	4	4
3H	Hex Nut, 7/16" -14	80860406	4	4	4	4	4
3J	5" RC-STD Draft Control	8116287	1	1	---	---	---
	6" RC-STD Draft Control	8116288	---	---	1	1	---
	7" RC-STD Draft Control	8116289	---	---	---	---	1
3K	Temperature & Pressure Gauge, 3-1/4" Dia., ENFM #4104-3-1/4-1/4-10 CHR	8056263	1	1	1	1	1
3L	Cast Iron Supply Manifold, 1-1/2" NPT	100082-01	1	1	1	1	1
3M	Honeywell #123870A Immersion Well, 3/4" NPT x 1-1/2" Insulation	80160426	1	1	1	1	1
3N	Control/Harness Assembly, Honeywell L7248C1014 High Limit & Circ. Relay	100085-01	1	1	1	1	1
	(Note: Control Only, Honeywell L7248C1014)	100059-01	1	1	1	1	1
3P	Cast Iron Return Manifold, 1-1/2" NPT	100083-01	1	1	1	1	1
3Q	Relief Valve, 3/4" NPT M x F, Conbraco #10-407-05	30 PSI	81660363	1	1	1	1
	Relief Valve, 3/4" NPT F x F, Conbraco #10-303-07	40 PSI	81660370*				
	Relief Valve, 3/4" NPT F x F, Conbraco #10-303-10	50 PSI	81660302*				
3R	Nipple, 1-1/4" NPT x 5" Lg.	100090-01	1	1	1	1	1
3S	Tee, 1-1/4" x 1-1/4" x 3/4" NPT	806601032	1	1	1	1	1
3T	Pipe Plugs 1-1/4" NPT	806603502	1	1	1	1	1
3U	Drain Valve, 3/4" NPT, Conbraco #35-302-03	806603061	1	1	1	1	1
3V	Self Drilling TEK Screw, #10 x 1/2", Hex Washer Head	80860711	3	3	3	3	3
Optional Controls Available but Not Included with Standard Water Boiler							
3W	Auxiliary Limit Kit, Control/Harness Assembly, Honeywell L4080B1212	100107-01	1	1	1	1	1
3X	Auxiliary Probe LWCO Kit, Control/Harness Assembly, Hydrolevel 1150	100106-01	1	1	1	1	1

* 3/4" NPT close pipe nipple must be field supplied for installation of this valve

Item No.	Description	Part No.	MPO147	MPO189	MPO231
4. DIRECT VENT KITS AND PARTS					
4A	Direct Vent Conversion Kit	102130-02	1	1	---
	Direct Vent Conversion Kit	102130-03	---	---	1
Not Shown	Adapter, Appliance, FDVS, 5-6	100234-02	1	1	---
	Adapter, Appliance, FDVS, 6-7	100234-03	---	---	1
	Clamp, 6" Appliance, FDVS-6, Half	100235-02	2	2	---
	Clamp, 7" Appliance, FDVS-7, Half	100235-03	---	---	2
	Assy., Cover Sleeve, FDVS-5	100236-02	2	2	---
	Assy., Cover Sleeve, FDVS-6	100236-03	---	---	2
	Assy., Cover Ring, FDVS-5	100237-02	2	2	---
	Assy., Cover Ring, FDVS-6	100237-03	---	---	2
	Clamp, Inner Pipe FDVS-5, Half	100238-02	4	4	---
	Clamp, Inner Pipe FDVS-6, Half	100238-03	---	---	4
5. FLEX OIL VENT PIPE					
Not Shown	5" Dia. x 5 ft. FOVP-505	100211-02	1	1	---
	5" Dia. x 10 ft. FOVP-510	100212-02			
	5" Dia. x 15 ft. FOVP-515	100213-02			
	5" Dia. x 20 ft. FOVP-520	100214-02			
	6" Dia. x 5 ft. FOVP-605	100211-03	---	---	1
	6" Dia. x 10 ft. FOVP-610	100212-03			
	6" Dia. x 15 ft. FOVP-615	100213-03			
	6" Dia. x 20 ft. FOVP-620	100214-03			

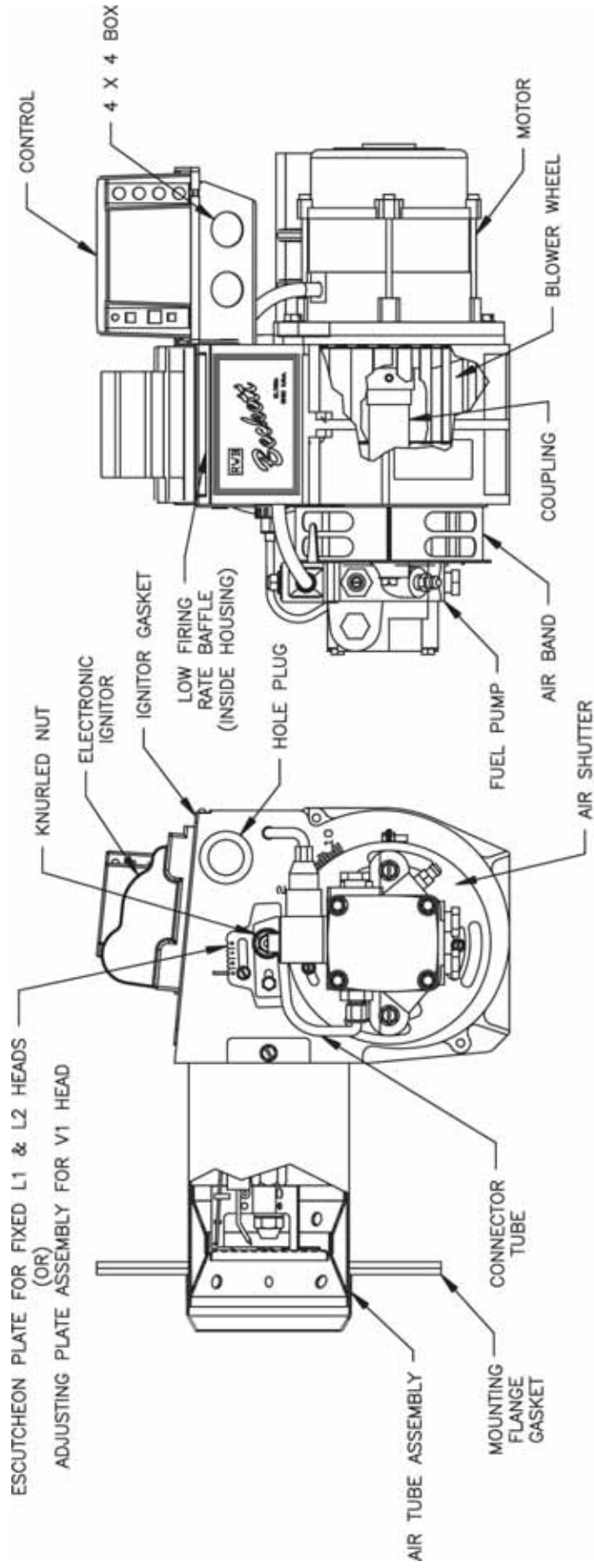

FRONT VIEW

SIDE VIEW

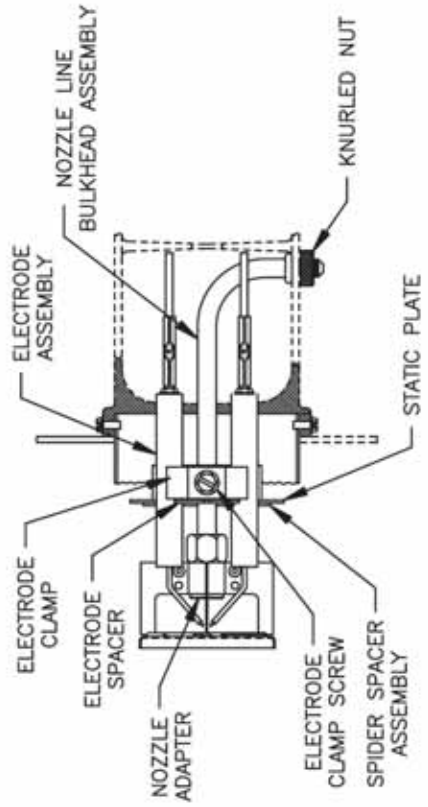

NOZZLE DETAIL

**BECKETT OIL BURNER PART NOS. FOR MPO SERIES BOILERS
NATURAL DRAFT APPLICATIONS**

NOTE: When ordering parts always give the serial and model numbers shown on the boiler and burner. Also provide the name of the part(s) and part number as listed below.

Boiler Model	MPO84	MPO115	MPO147	MPO189	MPO231
Air Tube Combination	AFG70MQASN	AFG70MPASN	AFG70MMAQN	AFG70MLASN	AFG70MKASN
Beckett's Spec. No.	BCB7702	BCB7707	BCB7703	BCB7704	BCB7705
Air Band	31840	31840	3492	3492	3492
Air Band Nut	4150	4150	4150	4150	4150
Air Band Screw	4198	4198	4198	4198	4198
Air Shutter	3709	3709	3709	3709	3709
Air Shutter Screw	4198	4198	4198	4198	4198
Blower Wheel	2999	2999	2999	2999	2999
Coupling	2454	2454	2454	2454	2454
Low Firing Rate Baffle	3708	---	---	---	---
Bulkhead Knurled Locknut	3666	3666	3666	3666	3666
Connector Tube Assembly	5636	5636	5636	5636	5636
Electrode Clamp	149	149	149	149	149
Electrode Clamp Screw	4219	4219	4219	4219	4219
Electrode Insulator Assembly	5780	5780	5780	5780	5780
Spider Spacer Assembly	5503	5503	5503	5503	5503
Escutcheon Plate	3493	3493	3493	5941	5941
Adjusting Plate Assembly	---	---	---	5941	5941
Head	51895	51895	5912	5913G	5913G
Head Screws	4221	4221	4221	4221	4221
Flange Gasket	32388	32388	32388	32388	32388
AFG Housing	5874	5874	5874	5874	5874
Motor	21805	21805	21805	21805	21805
Nozzle Adapter	213	213	213	213	213
Nozzle Line Electrode Assembly	NL70MB	NL70MB	NL70MM	NL70MD	NL70MD
Oil Pump, Clean Cut (Single Stage)	2184404U	2184404U	2184404U	2184404U	2184404U
Oil Pump, Clean Cut (Two-Stage)	51975U	51975U	51975U	51975U	51975U
Static Plate	3384	3383	3384	---	31905P
Ignitor	51771U	51771U	51771U	51771U	51771U
Ignitor Hinge Screw	4217	4217	4217	4217	4217
Ignitor Holding Screw	4292	4292	4292	4292	4292
Ignitor Gasket Kit	51304	51304	51304	51304	51304
Wire Guard	10251	10251	10251	10251	10251
Junction Box	5770	5770	5770	5770	5770
Flame Detector	7006	7006	7006	7006	7006
Oil Solenoid Valve Coil	21775U	21775U	21775U	21775U	21775U
Oil Solenoid Valve Cord	21807	21807	21807	21807	21807

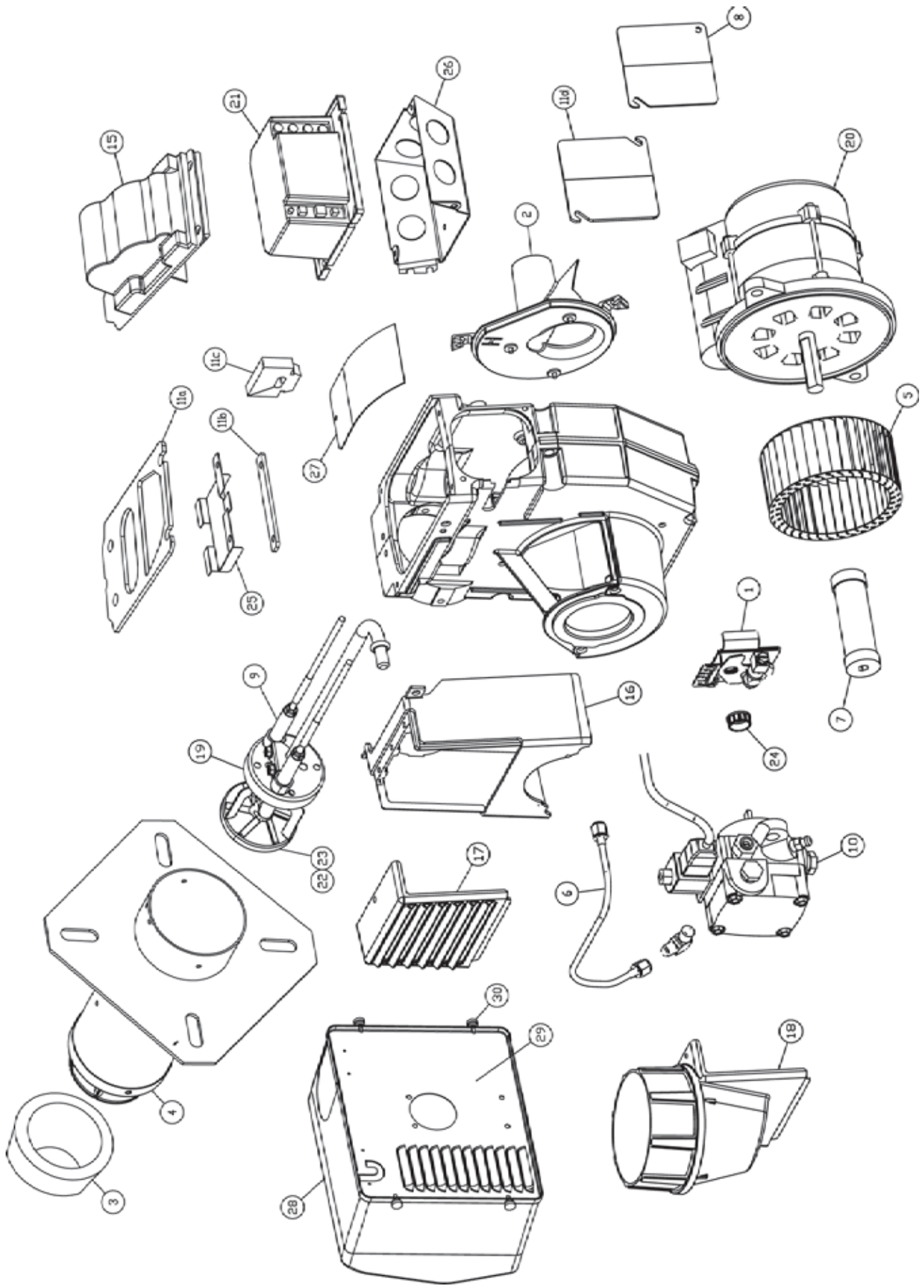

Beckett NX Burner

**BECKETT OIL BURNER PART NOS. FOR MPO SERIES BOILERS
DIRECT VENT APPLICATIONS**

NOTE: When ordering parts always give the serial and model numbers shown on the boiler and burner. Also provide the name of the part(s) and part number as listed below.

Item No.	Part Description	MPO147	MPO189	MPO231
		Beckett Part Numbers		
	Complete Oil Burner (without Primary Control)	BCB7903	BCB7904	BCB7905
1	Air Adjustment Mechanism Assembly	51794U		
2	Air Guide	101101U		
3	Heat Shield (where used/optional)	Specify		
4	Air Tube Combination	NX70LB	NX90LD	
	Air Tube Mounting Screws #8 x 3/8"	4396		
5	Blower Wheel	29994U		
6	Connector Tube Assembly, 11"	51127		
7	Coupling	2454		
8	Rear Access Door	32119U		
9	Electrodes Insulator Kit	51811U		
10	Fuel Unit, Single Stage, A2EA6520N621L	2184404U		
	Fuel Unit, Two Stage	51975U		
	Mounting Screws 1/4 -20 x 7/8"	4189		
11a	Gasket, Igniter Baseplate	51942U		
11b	Gasket, Igniter Baseplate Hinge			
11c	Gasket, Wiring			
11d	Gasket, Rear Access Door			
15	Igniter, Electronic	51771U		
16	Inlet Air Box	1010U		
18	Inlet Air Adapter, Outside Air Kit	1014U		
19	Nozzle Line Electrode and Head Assembly	Specify		
20	Motor	21805U		
	Mounting Screws 1/4 -20 x 7/8"	4189		
21	Primary Safety Control	Specify		
22	Retention Head Assembly - 6 Slot	51785U		
23	Retention Head Assembly - 9 Slot	51815U		
24	Splined Nut	3666		
25	Spring, Igniter Prop	32058PU		
26	Wiring Box	5770		
27	Low Firing Rate Baffle (If applicable)	32229U		
28	Cover, Burner	51812U		
29	Mounting Plate, Burner Cover	32103U		
30	Thumbscrews, Cover Mounting	21899U		
Not Shown	Gasket, Flange	32087		
	Main Housing Assembly	51783		
	Nozzle Line Heater (If applicable)	51621		

RIELLO OIL BURNER PART NUMBERS FOR MPO SERIES BOILERS

NOTE: When ordering parts always give the serial and model numbers shown on the boiler and burner.

Refer to Models F3 & F5 Installation Manual, Riello 40 Series Residential Oil Burners (C6501010) or Model F10 Installation Manual, Riello 40 Series Residential Oil Burners (2902554) for an exploded view of the burner and a list of spare parts.

For replacement Riello oil burner parts, contact your wholesaler or the burner manufacturer:

Riello Corporation of America
35 Pond Park Road
Hingham, Massachusetts 02043
Telephone: (617) 749-8292
Facsimile: (617) 740-2069
Toll Free: (outside Massachusetts)
(800) 992-7637

Riello Canada Inc.
2165 Meadowpine Blvd.
Mississauga, Ontario L5N 6H6
Telephone: (905) 542-0303
Facsimile: (905) 542-1525
Toll Free: (800) 387-3898

XV. LOW WATER CUT-OFF (LWCO) ON HOT WATER BOILERS

WARNING

DO NOT ATTEMPT to cut factory wires to install an aftermarket Low Water Cut Off (LWCO). Only use connections specifically identified for Low Water Cut Off.

In all cases, follow the Low Water Cut Off (LWCO) manufacturer's instructions.

When

A low water cut-off is required to protect a hot water boiler when any connected heat distributor (radiation) is installed below the top of the hot water boiler (i.e. baseboard on the same floor level as the boiler). In addition, some jurisdictions require the use of a LWCO with every hot water boiler.

Where

The universal location for a LWCO on both gas and oil hot water boilers is above the boiler, in either the supply or return piping. The minimum safe water level of a water boiler is at the uppermost top of the boiler; that is, it must be full of water to operate safely. Provisions have been made on the MPO supply manifold for a LWCO.

What Kind

Typically, in residential applications, a probe type LWCO is used instead of a float type, due to their relative costs and the simplicity of piping for a probe LWCO.

How to Pipe

Attach the LWCO to the 3/4" NPT connection on the supply manifold. See Figure A2 for more details.

Ideally, manual shutoff valves should be located above the LWCO and the boiler to allow for servicing. This will allow probe removal for inspection without draining the heating system. Many probe LWCO manufacturers recommend an annual inspection of the probe.

How to Wire

A. AFTERMARKET LWCO

The 120 VAC configuration can be universally applied to both gas and oil boilers by wiring it in the line voltage service to the boiler (after the service switch, if so equipped).

The presence of water in a properly installed LWCO will cause the normally open contact of the LWCO to close, thus providing continuity of the 120 VAC service to the boiler.

It is recommended to supply power to the probe LWCO with the same line voltage boiler service as shown in Figure A1. See Figure 34A or 34B (of this manual) for more details.

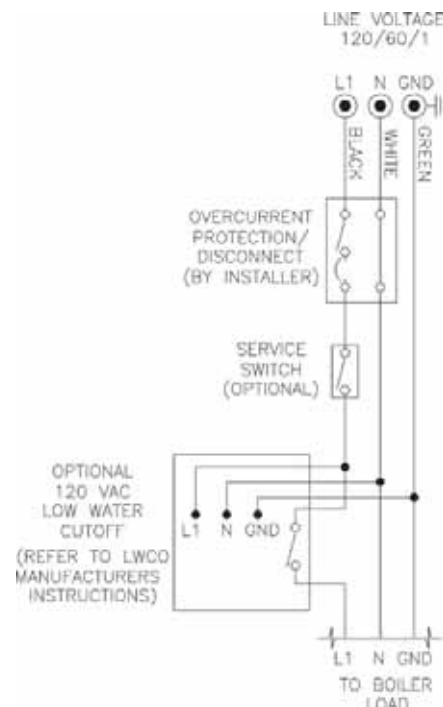

Figure A1: Wiring of Aftermarket LWCO

B. MPO LWCO

To simplify installation, the MPO LWCO can be easily installed by removing the LWCO jumper inside the internal junction box and connecting the harness into the boiler Molex plug. Refer to Section II, Paragraph F, Item 2 (of this manual) for more details.

How to Test

Shut off fuel supply. Lower water level until water level is BELOW the LWCO. Generate a boiler demand by turning up thermostat. Boiler should not attempt to operate. Increase the water level by filling the system. The boiler should attempt to operate once the water level is above the LWCO.

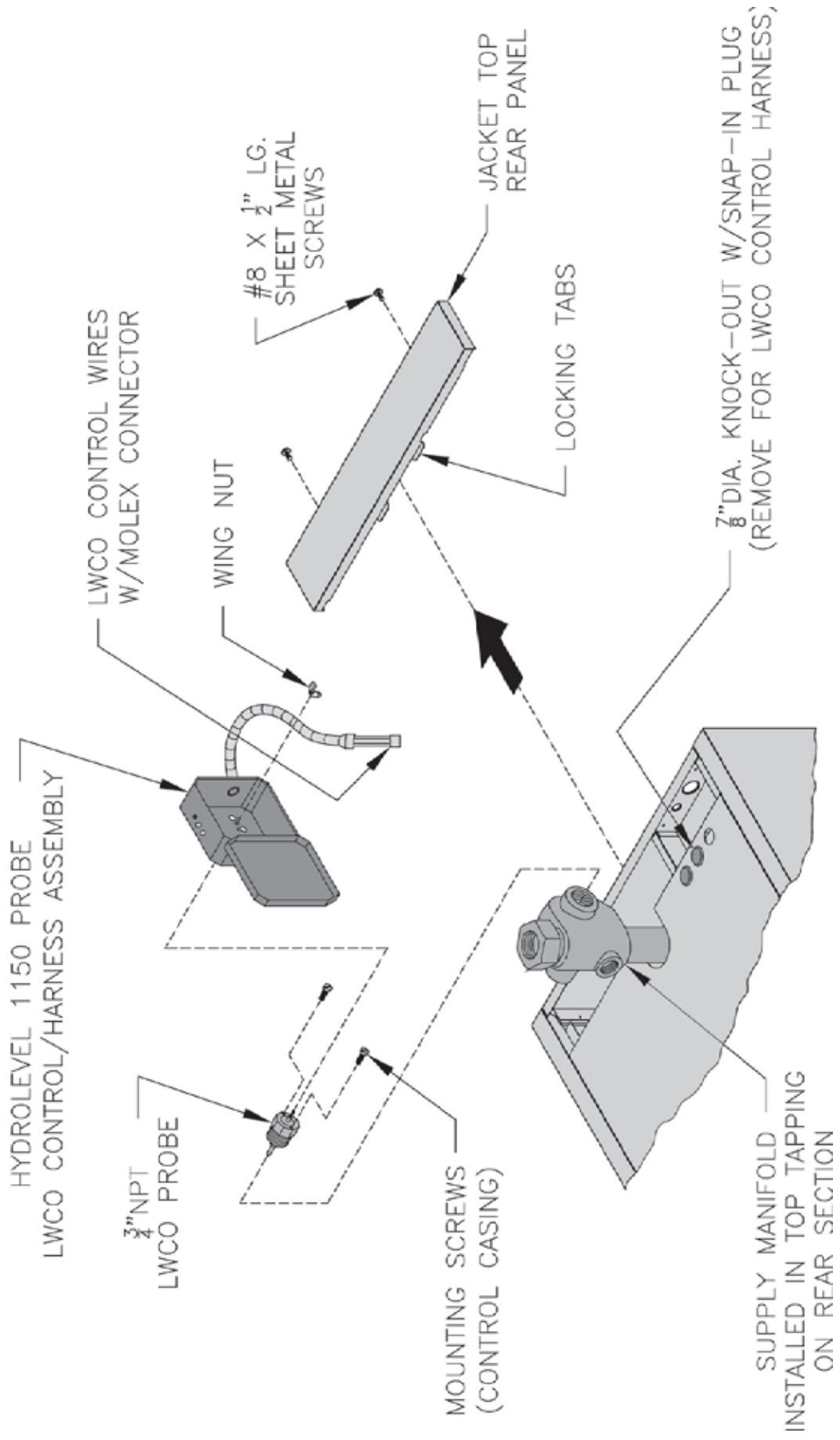

Figure A2: LWCO Location

TABLE 13: BURNER SPECIFICATIONS - CHIMNEY VENT

Beckett										Riello												
Boiler Model	Burner Input (GPH)	Burner Model	Nozzle	Air Shutter (setting)	Air Band (setting)	Pump Pressure (PSI)	Pump Type (setting)	Head Type (setting)	Insertion Depth (Inch)	Burner Model	Nozzle	Air Gate (setting)	Turbulator (setting)	Pump Pressure (PSI)	Combustion Head	Insertion Depth (Inch)	Approx. Shipped CO ₂ (%)	Baffle Location (pass)	Approx. Stack Temp. Increase Without Baffles °F (2)	Approx. Breech Pressure (" w.c.) (3)	Baffles IN Approx. Overfire Pressure (" w.c.) (3)	Baffles OUT Approx. Overfire Pressure (" w.c.) (3)
MPO84	0.60	AFG	0.50 x 45W Delavan	6 (1)	0	150	L2	2									11.5	3 rd	52	0	+0.010	+0.005
MPO115	0.82	AFG	0.65 x 45B Delavan	6	0	150	L2	2									11.5	2 nd & 3 rd	84	0	+0.040	+0.020
MPO147	1.05	AFG	0.85 x 60B Delavan	7	1	150	L1	2		F5	0.85 x 60 th B Delavan	2.7	1.0	145	LBT 10.0"	10	11.5	2 nd	65	0	+0.040	+0.020
MPO189	1.35	AFG	1.10 X 60B Hago	7	2	150	V1 (0)	2		F5	1.10 x 60 th B Delavan	4.5	3.0	150	SBT 6"	3.5	11.5	2 nd	39	0	+0.040	+0.030
MPO231	1.65	AFG	1.35 x 60B Hago	7	2	150	V1 (3)	2		F5	1.35 x 60 th B Delavan	3.5	4.0	145	VSBT	2.25	11.5	2 nd	18	0	+0.050	+0.030

Notes

- (1) MPO84 at 0.60 GPH firing rate utilizes a low fire baffle.
- (2) The increased stack temperature with the baffles removed is an approximation, based on a constant supply temperature of 180°F and 11.5% CO₂. Actual field conditions may be different.
- (3) These values are minimum and could be as much as -.03" w.c., more without impacting performance. Pressures based on 11.5% CO₂. Example: MPO231 could have a breech pressure of -.03" w.c. and an overfire pressure of .020" w.c.
- (4) Single stage fuel pump is standard, two-stage fuel pump is optional. Burner manufacturer has preset single stage fuel pump to settings shown in table above. Two-stage fuel pump is factory set at 140 PSI and must be readjusted to settings shown above during burner start-up.

TABLE 13A: MPO NX BURNER SPECIFICATIONS - DIRECT VENT

Boiler Model	Burner Input (GPH)	Head /Air Adjustment (setting)	Nozzle	Pump Pressure (PSI)	Approx. Shipped CO ₂ (%)	Baffle Location (pass)	Approx. Stack Temp. Increase Without Baffles °F (2)	Baffles IN Minimum Overfire Pressure (" w.c.) (3)	Baffles OUT Minimum Overfire Pressure (" w.c.) (3)	Baffles IN Minimum Breech Pressure (" w.c.) (3)	Baffles OUT Minimum Breech Pressure (" w.c.) (3)
MPO147DV	1.05	2.75	Hago 0.85 - 60 th B	150			75	+0.045	+0.03	+0.06	+0.045
MPO189DV	1.35	1.00	Hago 1.00 - 45 th B	180	11.5	2 nd	70	+0.08	+0.04	+0.10	+0.05
MPO231DV	1.65	2.25	Hago 1.25 - 45 th B				23	+0.06	+0.07	0	

Notes

- (2) The increased stack temperature with the baffles removed is an approximation, based on a constant supply temperature of 180°F and 11.5% CO₂. Actual field values may be different.
- (3) These values are representative for max vent and air intake piping conditions @ 180°F supply water temperature and 11.5% CO₂. Actual field values may be different.
- (4) Single stage fuel pump is standard, two-stage fuel pump is optional. Burner manufacturer has preset single stage fuel pump to settings shown in table above. Two-stage fuel pump is factory set at 140 PSI and must be readjusted to settings shown above during burner start-up.

Limited Warranty

FOR RESIDENTIAL CAST IRON WATER BOILERS

Subject to the terms and conditions set forth below, U.S. Boiler™ Co., Inc. Lancaster, Pennsylvania hereby extends the following limited warranties to the original owner of a residential grade water boiler manufactured and shipped on or after July 1, 1991:

ONE YEAR LIMITED WARRANTY ON RESIDENTIAL GRADE WATER BOILERS

U.S. Boiler Co., Inc. warrants to the original owner that its residential grade water boilers comply at the time of manufacture with recognized hydronic industry standards and requirements then in effect and will be free of defects in material and workmanship under normal usage for a period of one year from the date of original installation. If any part of a water boiler is found to be defective in material or workmanship during this one year period, U.S. Boiler Co., Inc. will, at its option, repair or replace the defective part.

LIFETIME LIMITED WARRANTY ON HEAT EXCHANGER

U.S. Boiler Co., Inc. warrants to the original owner that the heat exchanger of its residential grade water boilers will remain free from defects in material and workmanship under normal usage for the lifetime of the original owner at the original place of installation. If a claim is made under this warranty during the first ten years from the date of original installation, U.S. Boiler Co., Inc. will, at its option, repair or replace the heat exchanger. If a claim is made under this warranty after the expiration of ten years from the date of original installation, U.S. Boiler Co., Inc. will, at its option and upon payment of the pro-rated service charge set forth below, repair or replace the heat exchanger. The service charge applicable to a heat exchanger warranty claim is based upon the number of years the heat exchanger has been in service and will be determined as a percentage of the retail price of the heat exchanger model involved at the time the warranty claim is made as follows:

Years In Service	1-10	11	12	13	14	15	16	17
Service Charge as % of Retail Price	No Charge	5	10	15	20	25	30	35
Years In Service	18	19	20	21	22	23	24	25 and above
Service Charge as % of Retail Price	40	45	50	55	60	65	70	75

NOTE: If the heat exchanger model involved is no longer available due to product obsolescence or redesign, the value used to establish the retail price will be the published price as shown in the Burnham Hydronics Repair Parts Price Sheet where the heat exchanger last appeared or the current retail price of the then nearest equivalent heat exchanger.

ADDITIONAL TERMS AND CONDITIONS

- 1. Applicability:** The limited warranties set forth above are extended only to the original owner at the original place of installation within the United States and Canada. These warranties are applicable only to water boilers designated as residential grade by U.S. Boiler Co., Inc. and installed in a single or two-family residence and do not apply to steam boilers of any kind or to commercial grade boilers.
- 2. Components Manufactured by Others:** Upon expiration of the one year limited warranty on residential grade water boilers, all boiler components manufactured by others but furnished by U.S. Boiler Co., Inc. (such as oil burner, circulator and controls) will be subject only to the manufacturer's warranty, if any.
- 3. Proper Installation:** The warranties extended by U.S. Boiler Co., Inc. are conditioned upon the installation of the residential grade water boiler in strict compliance with U.S. Boiler Co., Inc. installation instructions. U. S. Boiler Co., Inc. specifically disclaims liability of any kind caused by or relating to improper installation.
- 4. Proper Use and Maintenance:** The warranties extended by U.S. Boiler Co., Inc. are conditioned upon the use of the residential grade water boiler for its intended purposes and its maintenance

accordance with U. S. Boiler Co., Inc. recommendations and hydronics industry standards. These warranties will be inapplicable if the residential grade water boiler is used or operated over its rated capacity, is subjected to unauthorized modification, or is damaged as a result of being otherwise improperly operated or serviced including, but not limited to, damage from any of the following: operation with insufficient water, allowing the boiler to freeze, subjecting the boiler to flood conditions, and operation with unapproved water or fuel additives which cause deposits or corrosion.

- 5. Removal and Installation:** These warranties do not cover expenses of removal or reinstallation. The owner is responsible for the cost of removing and reinstalling any defective part and its replacements and all labor and material connected therewith.
- 6. Exclusive Remedy:** U.S. Boiler Co., Inc. obligation for any breach of these warranties is limited to the repair or replacement of its parts in accordance with the terms and conditions of these warranties.
- 7. Limitation of Damages:** Under no circumstances shall U.S. Boiler Co., Inc. be liable for incidental, indirect, special or consequential damages of any kind whatsoever under these warranties, including, but not limited to, injury or damage to persons or property and damages for loss of use, inconvenience or loss of time. U.S. Boiler Co., Inc. liability under these warranties shall under no circumstances exceed the purchase price paid by the owner for the residential grade water boiler involved. Some states do not allow the exclusion or limitation of incidental or consequential damages, so the above limitation or exclusion may not apply to you.
- 8. Limitation of Warranties:** These warranties set forth the entire obligation of U.S. Boiler Co., Inc. with respect to any defect in a residential grade water boiler and U.S. Boiler Co., Inc. shall have no express obligations, responsibilities or liabilities of any kind whatsoever other than those set forth herein. These warranties are given in lieu of all other express warranties.

ALL APPLICABLE IMPLIED WARRANTIES, IF ANY, INCLUDING ANY WARRANTY OF MERCHANTABILITY OR FITNESS FOR A PARTICULAR PURPOSE ARE EXPRESSLY LIMITED IN DURATION TO A PERIOD OF ONE YEAR EXCEPT THAT IMPLIED WARRANTIES, IF ANY, APPLICABLE TO THE HEAT EXCHANGER IN A RESIDENTIAL GRADE WATER BOILER SHALL EXTEND TO THE ORIGINAL OWNER FOR THE LIFETIME OF THE ORIGINAL OWNER AT THE ORIGINAL PLACE OF INSTALLATION. SOME STATES DO NOT ALLOW LIMITATION ON HOW LONG AN IMPLIED WARRANTY LASTS, SO THE ABOVE LIMITATION MAY NOT APPLY TO YOU.

PROCEDURE FOR OBTAINING WARRANTY SERVICE

In order to assure prompt warranty service, the owner is requested to complete and mail the attached Warranty Card within ten days after the installation of the boiler, although failure to comply with this request will not void the owner's rights under these warranties.

Upon discovery of a condition believed to be related to a defect in material or workmanship covered by these warranties, the owner should notify the installer, who will in turn notify the distributor. If this action is not possible or does not produce a prompt response, the owner should write to U.S. Boiler Co., Inc., Burnham Hydronics, at P.O. Box 3079, Lancaster, PA 17604, giving full particulars in support of the claim.

The owner is required to make available for inspection by U.S. Boiler Co., Inc. or its representative the parts claimed to be defective and, if requested by U.S. Boiler Co., Inc. to ship these parts prepaid to U.S. Boiler Co., Inc. at the above address for inspection or repair. In addition, the owner agrees to make all reasonable efforts to settle any disagreement arising in connection with a claim before resorting to legal remedies in the courts.

THIS WARRANTY GIVES YOU SPECIFIC LEGAL RIGHTS AND YOU MAY ALSO HAVE OTHER RIGHTS WHICH VARY FROM STATE TO STATE.

