

E-STOP / TIMER OUTDOOR INSTALLATION INSTRUCTIONS

1. Check all parts in the packaging box against the list provided below
2. Wire the timer according to the wiring diagram:

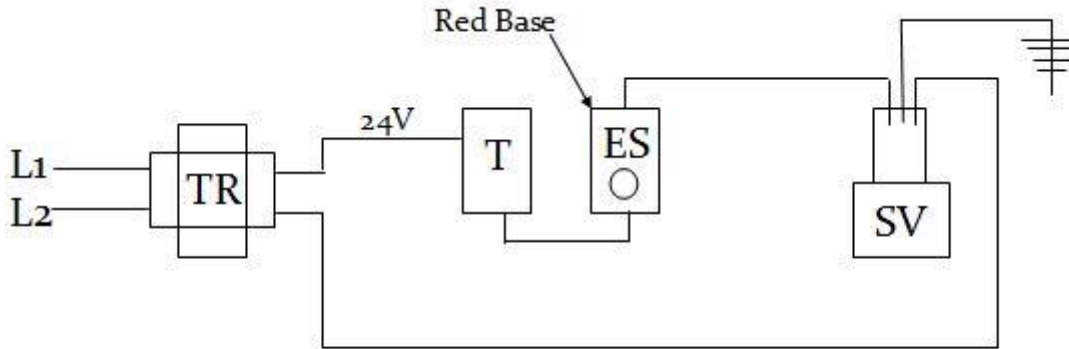

3. Mount the timer to the rough in box, using the 2 flat head screws provided with the timer
4. Put the E-Stop c/w 1-3/8" toggle base through the right side of the WP5220C Double-Gang In-Use box. Complete the wiring as per wiring diagram.
5. Mount the WP5220C Double-Gang In-Use box onto the CPDB2G Two Gang Non Metallic Device Box. Secure with screws provided
6. Install timer face plate using the hex nut
7. Install timer knob
8. Install the clear cover to the WP5220C Double-Gang In-Use box using hinge pin provided.

Note: The 24 Volt solenoid valve is sold separately and will have to be wired to the E-Stop/Timer according to the wiring diagram. Please note all gas and electrical work should be done by qualified trades people, following local codes.

Parts Included:

- WP5220C Double Gang In-Use Box including hardware package
- CPDB2G Two Gang Non-Metallic Device Box
- Emergency Stop
- Transformer
- FD2HW 2-Hour Spring Wound Countdown Timer including hardware package

BURNABY MANUFACTURING LTD.

#2190 – 580 Nicola Avenue, Port Coquitlam, BC V3B 0P2 TEL: (604) 877-1599 FAX: (604) 877-1599

EMAIL: info@bbymfg.com WEB: www.bbymfg.com