

**UPON COMPLETION OF THE INSTALLATION THE INSTALLER MUST INSTRUCT THE OWNER AND OPERATOR ON THE FUNCTIONALITY AND THE PROPER OPERATION OF THE BOILER AND THE HEATING SYSTEM
THIS MANUAL SHOULD BE HANDED TO THE OWNER AND OPERATOR OF THE APPLIANCE.
INSTALLER MUST REVIEW ALL SAFETY INSTRUCTIONS WITH THE OWNER AND OPERATOR.**

DANGER!

The installation instructions included in this Manual are intended solely for use by a trained and certified installer, service company or the gas supply company. If the information in this manual is not followed, a fire or explosion may result causing property damage, personal injury, or death.

- ▶ Have installation and service performed by a trained and certified installer or service company, or the gas supply company.
- ▶ Bosch recommends signing a service and maintenance contract with a trained and certified installer or service company that covers annual servicing and condition-based maintenance. Proper maintenance is a fundamental requirement for safe and efficient operation and long service life.
- ▶ The boiler must be serviced annually including the main burner, ignition burner, the entire venting system, and the combustion air supply. All parts that show any signs of damage or corrosion must be replaced.
- ▶ The owner and operator is responsible for the operational safety and regulatory compliance of the heating system.
- ▶ Improper installation, adjustment, alteration, service, or maintenance can cause property damage, personal injury, or death. Refer to this manual and consult a trained and certified installer or service company, or the gas supply company before installation, service or maintenance.

Stainless Steel Condensing Boiler

Buderus SB625WS/Buderus SB745WS

Low temperature condensing boilers for gas/oil fired power burners



BOSCH

Installation Instructions

Contents

1	Key to symbols and safety instructions	3
1.1	Explanation of symbols	3
1.2	General safety instructions	3
2	Product Description	5
2.1	Intended use	6
2.2	Certification and testing mark	6
2.3	Regulations and Guidelines	6
2.3.1	National regulation	6
2.3.2	Compliance with standards and regulations	6
2.3.3	Additional regulations for installations in the Commonwealth of Massachusetts	6
2.4	Suitable fuels	7
2.5	Scope of delivery	8
2.6	Accessories	8
2.7	Tools, materials and auxiliary equipment	8
2.8	Data plate	8
2.9	Dimensions and specifications	9
2.9.1	Dimensions	9
2.9.2	Technical Data	10
2.9.3	Water connections	11
3	Water treatment	13
3.1	Chemical and physical characteristics	13
3.2	Central heating system	13
3.2.1	Limescale deposits	13
3.2.2	Deposit corrosion	14
3.2.3	Stray current corrosion	14
3.2.4	Diffused and localized acid corrosion	14
3.3	New central heating systems	14
3.4	Reconditioning old heating systems	14
3.5	Elimination air and gas from central heating system	14
3.6	Use of Antifreeze	15
4	Transport	15
5	Installation	16
5.1	Boiler Clearances	16
5.2	Assembling the paneling	17
5.3	Refitting the door hinges	19
5.3.1	Changing the direction of door opening	19
5.3.2	Removing the hinge assembly "B"	22
5.4	Burners	22
5.5	Combustion gas exhaust	23
5.6	Venting Requirements	23
5.7	Code Required Vent Terminations	24
5.8	Combustion Air from outside the building	24
5.9	Combustion Air from an adjacent room	25
5.10	Condensate Removal	25
5.11	Condensate	25
5.11.1	Draining the condensate	25
5.11.2	Neutralizing the condensate	25
6	Commissioning	26
6.1	Control unit settings	26
6.2	Hydraulic connection to the heating system	27
6.3	Hydraulic flow through boiler	27
6.4	Making the electrical connection	28
6.5	Fitting temperature sensors	29
6.6	Flushing the heating system	29
6.7	Filling the heating system	30
6.8	Preparing the heating system for operation	30
6.9	Commissioning the control unit and burner	30
6.10	Setting control unit parameters	30
6.11	Commissioning report	31
7	Shutting down	32
7.1	Shutting down the heating system	32
7.2	Shutting down the heating system in an emergency	32
8	Inspection and maintenance	32
8.1	Why is regular maintenance important?	32
8.2	Maintenance	32
8.2.1	Opening the door	32
8.2.2	Adjusting the door	33
8.3	Cleaning the boiler	33
8.4	Checking and correcting the water pressure	34
8.4.1	When should you check the water pressure in the heating system?	34
8.4.2	Sealed unvented systems	35
8.5	Inspection and maintenance reports	36
9	Spare parts	38
10	Troubleshooting	45
11	Environmental protection/disposal	46
12	Glossary	47
	Index	49

1 Key to symbols and safety instructions

1.1 Explanation of symbols

Warnings



Warnings in this document are identified by a warning triangle printed against a grey background.

Keywords at the start of a warning indicate the type and seriousness of the ensuing risk if measures to prevent the risk are not taken.

The following keywords are defined and can be used in this document:

- **NOTE** indicates that property damage may occur.
- **CAUTION** indicates that personal injury may occur.
- **WARNING** indicates that severe personal injury may occur.
- **DANGER** indicates that severe personal injury or death may occur.

Important information



Important information for the proper use of the boiler is also provided in this manual. You will find the information with a symbol shown on the left and bordered by horizontal lines above and below the text.

Additional symbols

Symbol	Meaning
▶	Sequence of steps
→	Cross-reference to other points in this document or to other documents
•	Listing/list entry
–	Listing/list entry (2nd level)

Table 1 Additional symbols

1.2 General safety instructions

If you hear gas leaking

- ▶ Leave the building immediately.
- ▶ Prevent others from entering the building.
- ▶ Notify the police and fire department from outside the building.
- ▶ From outside the building, call the gas supply company and a trained and certified installer or service company.

If you smell gas

- ▶ Turn off the gas shut-off valve.
- ▶ Open windows and doors
- ▶ Do not touch any electrical switch, telephone, and do not use outlets.
- ▶ Extinguish all open flames.
- ▶ Do not smoke!
- ▶ Do not use lighters!
- ▶ Warn all occupants of the building that they need to leave the building.
- ▶ Do not ring doorbells!
- ▶ Notify the police and fire department from outside the building.
- ▶ From outside the building, call the gas supply company and a trained and certified installer or service company.

If you smell flue gas

- ▶ Switch off the appliance.
- ▶ Open windows and doors.
- ▶ Inform a trained and certified heating contractor.

DANGER: Risk of fatal injury from failing to consider your own safety!

- ▶ Never risk your own life. Your own safety must always take the highest priority

NOTICE: Risk of appliance damage from improper operation of the boiler!

- ▶ Only use the boiler for its intended purpose.
- ▶ Only operate the boiler if it has been installed and maintained per the instructions provided in the Installation Manual.
- ▶ Do not attempt to operate an appliance if any part of it is not in working order or is damaged.
- ▶ Use only original spare parts! The use of parts not supplied by the manufacturer may cause damage to the boiler, other property and personal injury. Also, boiler damage caused by the use of unauthorized parts is not covered by the warranty.

DANGER: Risk of fire when soldering and brazing!

- ▶ Take appropriate protective measures when soldering and brazing around combustible and flammable material.

NOTICE:

- ▶ The installation must comply with all applicable national, state, and local codes, rules, and regulations.
- ▶ The operator is responsible for the operational safety and regulatory compliance of the heating system.

DANGER: Risk of personal injury or death from flue gas poisoning!

- ▶ Do not install a thermostatic flue gas damper downstream of the draft hood.
- ▶ Do not tamper with, remove, or attempt to repair the blocked vent switch.
- ▶ When replacing the blocked vent switch, install the new part in the original location.
- ▶ A blocked vent switch tripping more than once indicates a problem with the venting system or chimney which must be repaired immediately.
- ▶ Ensure none of the vent pipes and chimneys are damaged or blocked.
- ▶ Connect only one appliance to each venting system or chimney.
- ▶ The venting system must not feed into or route through another air extraction duct.
- ▶ The venting system must be inspected annually. All parts that show any signs of damage or corrosion must be replaced.
- ▶ Never close off or reduce the size of the combustion air openings.
- ▶ The boiler must not be operated until any obstructions have been removed.

DANGER: Risk of personal injury or death from explosion!

- ▶ Work on gas components may only be carried out by a trained and certified installer or service company.
- ▶ Appliance installation, the connection of gas and vent piping, initial commissioning, electrical connections, and service and maintenance must only be carried out by a trained and certified installer or service company.

DANGER: Risk of personal injury or death from fire!

- ▶ Do not use flammable or combustible material in the boiler room.
- ▶ It is recommended not to store any items within 16 inches (415mm) of the appliance

CAUTION: Appliance damage from contaminated combustion air!

- ▶ Keep the combustion air free of corrosive substances, e.g. halogenated hydrocarbons from painting operations or beauty salons.
- ▶ Keep combustion air free from dust and lint, e.g. from laundry or agricultural operations.
- ▶ If clean room air is not available, fresh outdoor combustion air must be provided

DANGER: Risk of personal injury or death from electric shock.

- ▶ Before removing the front panel, disconnect the heating system from the electrical power supply by shutting off the emergency shutoff switch or the heating system circuit breaker.
- ▶ It is not enough to switch off the control panel. **Power to the panel must be disconnected!** Ensure that the power is not restored unintentionally by following proper lock out/tag out procedures.
- ▶ Only qualified electricians are permitted to carry out electrical work.

DANGER: Safety devices!

- ▶ Never shut off safety valves!
- ▶ Hot water may escape from the safety valve at any time when the appliance is running.

DANGER: Risk of personal injury or death after a flood!

- ▶ Do not attempt to operate an appliance if any part of it has been under water.
- ▶ An appliance that was subject to flooding must be replaced.

NOTICE:

- ▶ Upon completion of the installation, these instructions should be handed to the owner and operator of the appliance.
- ▶ The installer must instruct the owner and operator on the functionality of the components and the proper operation of the boiler and the heating system.
- ▶ The boiler must be serviced annually including the main burner, ignition burner, the entire venting system, and the combustion air supply. All parts that show any signs of damage or corrosion must be replaced.

2 Product Description

The high efficiency SB Series boilers are designed to condense flue gases through a unique three-pass construction for installation in a mechanical room. While they are designed primarily for central heating purposes, in conjunction with a suitable storage tank they can also be used to produce domestic hot water.

All parts that come into contact with the combustion gases are made from titanium stabilized stainless steel to ensure maximum resistance to the corrosive action of acid condensation.

The boiler has been designed with the combustion chamber at the top and the smooth pipe tube bundle at the bottom to optimize heat exchange and to maximize the condensing effect.

The boiler has a high total water content which is differentially distributed between its top and bottom sections. This hydraulic feature allows outgoing water to reach the set temperature quickly while

maintaining the condensing effect and the water heating time around the tube bundle for as long as possible.

The boilers feature lightly pressurized combustion chambers for a smoother burner action, and high temperature resistant, stainless steel turbulators inside the tube bundle for maximum burner efficiency.

The boiler body is thoroughly insulated with a layer of high density glass wool.

The paint finished external paneling is also internally insulated with a layer of high density glass wool.

The boiler's front door and the flue gas chamber can be opened completely to facilitate the inspection, maintenance and cleaning of internal parts and to speed up servicing in general.

The front door can open in either direction and can be opened without removing the burner. The door is factory fitted with hinges on the left, but these can be reversed if necessary to suit individual installations.

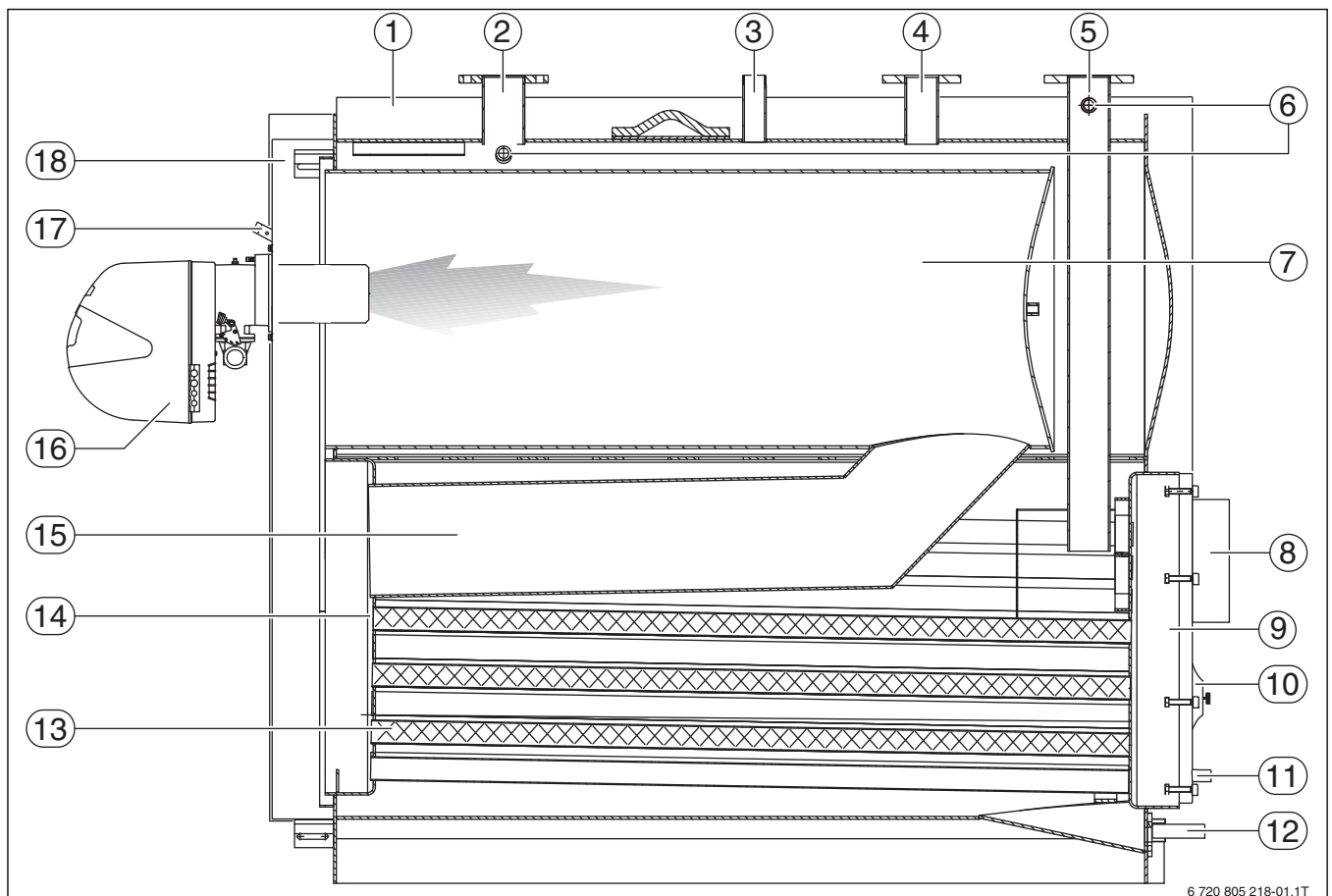

Fig. 1 Main components

- | | |
|--|--|
| [1] Paneling | [8] Flue connection |
| [2] Heating flow outlet | [9] Flue gas box |
| [3] Safety device fitting ¹⁾ | [10] Inspection port |
| [4] Heating return (high temperature) | [11] Condensate drain |
| [5] Heating return (low temperature) ²⁾ | [12] Boiler drain |
| [6] Instrument for bulb/probe socket | [13] Turbulators |
| [7] Combustion chamber | [14] Flue pipes |
| | [15] Second flue pass |
| | [16] Burner |
| | [17] Flame inspection window with pressure measurement point |
| | [18] Door |

1) On the 1550WS model the low temperature heating return is located at the rear of the boiler.

2) On the 745WS models (800-1550) the safety device fitting is flanged.

2.1 Intended use

This boiler must only be used for the purpose specified by the manufacturer and for which it is designed.

The SB625WS/SB745WS can be operated with gas, oil, and combination burners. For a list of the approved burners, please contact Bosch Thermotechnology Corp.

The boiler can be operated with an aquastat, the Logamatic 4000, and other control systems.

The manufacturer declines all responsibility, contractual or other, for damage to property or injury to persons or animals caused by improper installation, adjustment, maintenance or use.

2.2 Certification and testing mark

This appliance has been tested and certified and meets all applicable standards for the US and Canadian markets:

- CSA-AM 3.1 Industrial and commercial gas-fired package boilers
- CSA B140.0 General requirements for oil burning equipment
- CSA B140.2.1-10 Atomizing-type oil burners
- CSA B140.7-05 Oil-burning equipment - steam and hot water boilers
- UL 296 Standard for oil burners
- UL 726 Standard for oil-fired boiler assemblies
- UL 795 Standard for commercial industrial gas heating equipment

2.3 Regulations and Guidelines

2.3.1 National regulation

The heating system must comply with the requirements of the relevant regulatory authorities or otherwise of the National Fuel Gas Code, ANSI Z 223.1 In Canada, the requirements of CAN/CGA-B.149.1 and 2, or CAN/CGA-B.139 must be observed.

If specified by the relevant regulatory authorities, the heating system must comply with the regulations of the Standard for Controls and Safety Devices for Automatically Fired Boilers, ANSI/ASME CSD-1.

Carbon monoxide detectors must be installed as specified by the local regulations. The boiler must be serviced annually.

2.3.2 Compliance with standards and regulations

Installation of the boiler must comply with all applicable codes and regulations imposed by the national, Federal or local authorities and bodies. If no specific requirements are defined, in the USA, the latest edition of the National Fuel Gas Code ANSI Z223.1/NFPA 54 must be complied with.

In Canada, installation must comply in all respects with the latest edition of the Natural Gas and Propane Installation Code, CAN/CGA-B. 149, the Installation Code for Oil Burning Equipment, CAN/CGA-B. 139 and the applicable local regulations and requirements for the appliance category. The relevant authorities and regulatory bodies must be informed before installation starts.

Where required by local regulations, the system must comply with the American Society of Mechanical Engineers Safety Code for Controls and Safety Devices for Automatically Fired Boilers (ASME CSD-1).



WARNING: Risk of fatal Injury from explosion of flammable gases!

- ▶ Installation, connection of the fuel supply and flue pipe, commissioning, connection of the electrical power supply, servicing and repair may only be carried out by an authorized heating engineer.
- ▶ Any work on gas-carrying components may only be carried out by an authorized gas installer.

The local regulations regarding minimum pressure detectors and low-water safety cutouts must be observed. Installation and operation must comply with the device manufacturer's technical documentation.

We recommend fitting an 80 mesh dirt filter externally to the boiler return to prevent contamination of the boiler by the water source.

Leak test

A leak test must be carried out. The testing pressure is based on the normal operating pressure of the heating system and should be 1.3 times that pressure, and in any case no less than 14 psi (1 bar).



The details on the boiler rating plate are definitive and must be observed.

Safety limits

Safety limits	Value
Maximum allowable temperature:	230 °F (110 °C)
Maximum operating temperature	210 °F (98.8 °C)
Permissible operating pressure:	80 psi (5.5 bar)
Maximum cycle time for safety temperature limiter:	40 s
Maximum cycle time for temperature control:	40 s

Table 2 Safety limits

2.3.3 Additional regulations for installations in the Commonwealth of Massachusetts

(a) For all side wall horizontally vented gas fueled equipment installed in every dwelling, building or structure used in whole or in part for residential purposes, including those owned or operated by the Commonwealth and where the side wall exhaust vent termination is less than seven (7) feet above finished grade in the area of the venting, including but not limited to decks and porches, the following requirements shall be satisfied:

- **INSTALLATION OF CARBON MONOXIDE DETECTORS.** At the time of installation of the side wall horizontal vented gas fueled equipment, the installing plumber or gasfitter shall observe that a hard wired carbon monoxide detector with an alarm and battery back-up is installed on the floor level where the gas equipment is to be installed. In addition, the installing plumber or gasfitter shall observe that a battery operated or hard wired carbon monoxide detector with an alarm is installed on each additional level of the dwelling, building or structure served by the side wall horizontal vented gas fueled equipment. It shall be the responsibility of the property owner to secure the services of qualified licensed professionals for the installation of hard wired carbon monoxide detectors.
 - In the event that the side wall horizontally vented gas fueled equipment is installed in a crawl space or an attic, the hard wired

carbon monoxide detector with alarm and battery back-up may be installed on the next adjacent floor level.

- In the event that the requirements of this subdivision cannot be met at the time of completion of installation, the owner shall have a period of thirty (30) days to comply with the above requirements; provided, however, that during said thirty (30) day period, a battery operated carbon monoxide detector with an alarm shall be installed.
- APPROVED CARBON MONOXIDE DETECTORS. Each carbon monoxide detector as required in accordance with the above provisions shall comply with NPA 720 and be ANSI/UL 2034 listed and IAS certified.
- SIGNAGE. A metal or plastic identification plate shall be permanently mounted to the exterior of the building at a minimum height of eight (8) feet above grade directly in line with the exhaust vent terminal for the horizontally vented gas fueled heating appliance or equipment. The sign shall read, in print size no less than one-half (½) inch in size, "GAS VENT DIRECTLY BELOW. KEEP CLEAR OF ALL OBSTRUCTIONS".
- INSPECTION. The state or local gas inspector of the side wall horizontally vented gas fueled equipment shall not approve the installation unless, upon inspections, the inspector observes carbon monoxide detectors and signage installed in accordance with the provisions of 248 CRM 5.08(2)(a) 1 through 4.

(b) EXEMPTIONS: The following equipment is exempt from 248 CRM 5.08(2)(a) 1 through 4:

- The equipment listed in Section 10 entitled "Equipment Not Required To Be Vented" in the most current edition of NFPA 54 as adopted by the board; and
- Product Approved side wall horizontally vented gas fueled equipment installed in a room or structure separate from the dwelling, building or structure used in whole or in part for residential purposes.

(c) MANUFACTURERS REQUIREMENTS - GAS EQUIPMENT VENTING SYSTEM REQUIRED. When the manufacturer of Product Approved side wall horizontally mounted gas equipment provides a venting system design or venting system components with the equipment, the instructions provided by the manufacturer for the installation of the equipment and venting shall include:

- Detailed instructions for the installation of the venting system or the venting system components; and
- A complete parts list for the venting system design or venting system.

(d) MANUFACTURERS REQUIREMENTS - GAS EQUIPMENT VENTING SYSTEM NOT PROVIDED. When the manufacturer of Product Approved side wall horizontally vented gas fueled equipment does not provide the parts for the venting of flue gases, but identifies "special venting systems", the following requirements shall be satisfied by the manufacturer:

- The referenced "special venting systems" shall be included with the appliance or equipment installation instructions; and
- The "special venting systems" shall be Product Approved by the Board, and the instructions for that system shall include a parts list and detailed installation instructions.

(e) A copy of all instructions for all Product Approved side wall horizontally vented gas fueled equipment, all venting instructions, all parts lists for venting instructions, and/or venting design instructions shall remain with the appliance or equipment at the completion of the installation.

2.4 Suitable fuels

Permissible fuels

- Natural gas from the public gas supply in accordance with national regulations with a total sulphur content < 15ppm.
- LP in accordance with national regulations with a content of elementary sulphur < 1.5 ppm and volatile sulphur < 50 ppm.
- Ultra Low Sulphur Diesel in accordance with national regulations with a content of elementary sulphur < 15 ppm (for use as back-up fuel in condensing operation).
- Heating oil type 2 when boiler return temperature is not lower than 140 degrees Fahrenheit; non-condensing operation (for use as back-up fuel only). See the warranty statement for additional details.

NOTICE:

- ▶ Do not use gasoline, crankcase drainings, or any oil containing gasoline.



The boiler must only be operated with the specified fuels.

Only burners that are suitable for the specified fuels may be used.



Observe the manufacturer's burner selection list and the burner manufacturer's instructions.

2.5 Scope of delivery

The boilers SB625WS / SB745WS comes in two separate crates and one additional box.

Boiler body:



The instruction manual is an integral part of the boiler. Manuals are attached at the outside of the boiler. Replacement sealing rope for burner door and ceramic insulation are located behind the boiler door. Look at the attached red label at the burner observation port. Once located, read it thoroughly and keep it safe.

The boiler body bears the documentation envelope and contains:

- Instruction manual [1]
- Copy of H-2 Form
- Bar code labels
- Ceramic insulation (within combustion chamber)
- Data plate [2]

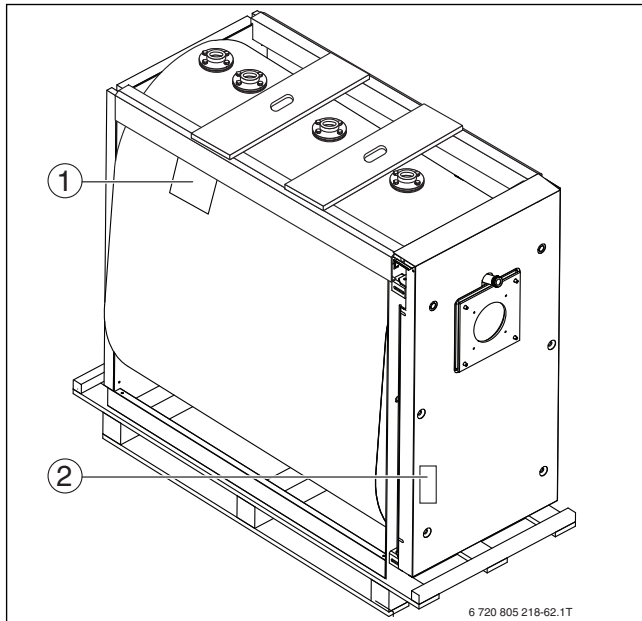

Fig. 2 Boiler body

Paneling crate:

The paneling crate, complete with assembly accessories, protected by cardboard packaging and a wooden crate.

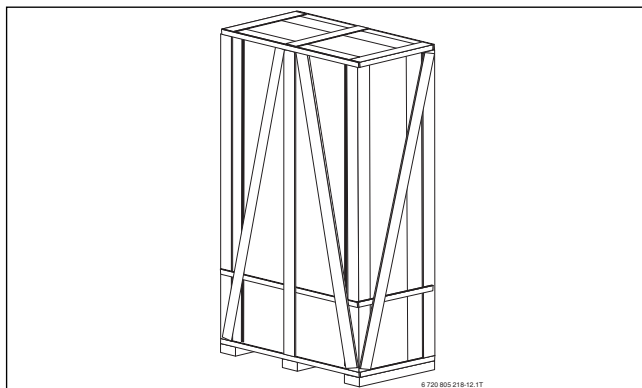

Fig. 3 Paneling crate

Accessory box:

The boiler accessory box contains

- Manifold
- Pressure relief valve
- Pressure/temperature gauge

Checking the delivery for completeness

- ▶ After delivery, check all packaging is in perfect condition.
- ▶ Check the delivery for completeness.
- ▶ Dispose of packaging in an environmentally responsible manner.

2.6 Accessories

Control panels

The control panels listed below may be supplied by the manufacturer for use with the SB625WS / SB745WS boilers.

Model	Description
	The Logamatic 4321 control unit is designed for low temperature and condensing operation in single or multiple boiler systems. Additional possible functions include DHW, mixed heating zones and solar thermal integration.

Table 3 Control panels

2.7 Tools, materials and auxiliary equipment

For the installation and maintenance of the boiler, standard tools are required, as used for heating, gas, water and electrical installations.

2.8 Data plate

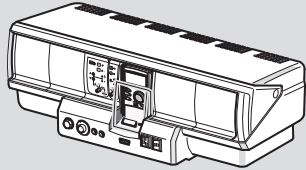

If you contact the manufacturer with any questions about this product, always provide the details on the data plate and serial number plate. These details enable us to assist you specifically and quickly.

Serial number plate

The serial number plate is located on the rear of the boiler block and specifies the serial number and model.

Data plate

This lists the appliance's technical specifications and performance. The data plate will be factory installed on the boiler panel.



If these plates or any other means of clearly identifying the product are defaced, removed or lost, proper installation and servicing may be difficult.

2.9 Dimensions and specifications



Values obtained with RS.../M-burners.

2.9.1 Dimensions

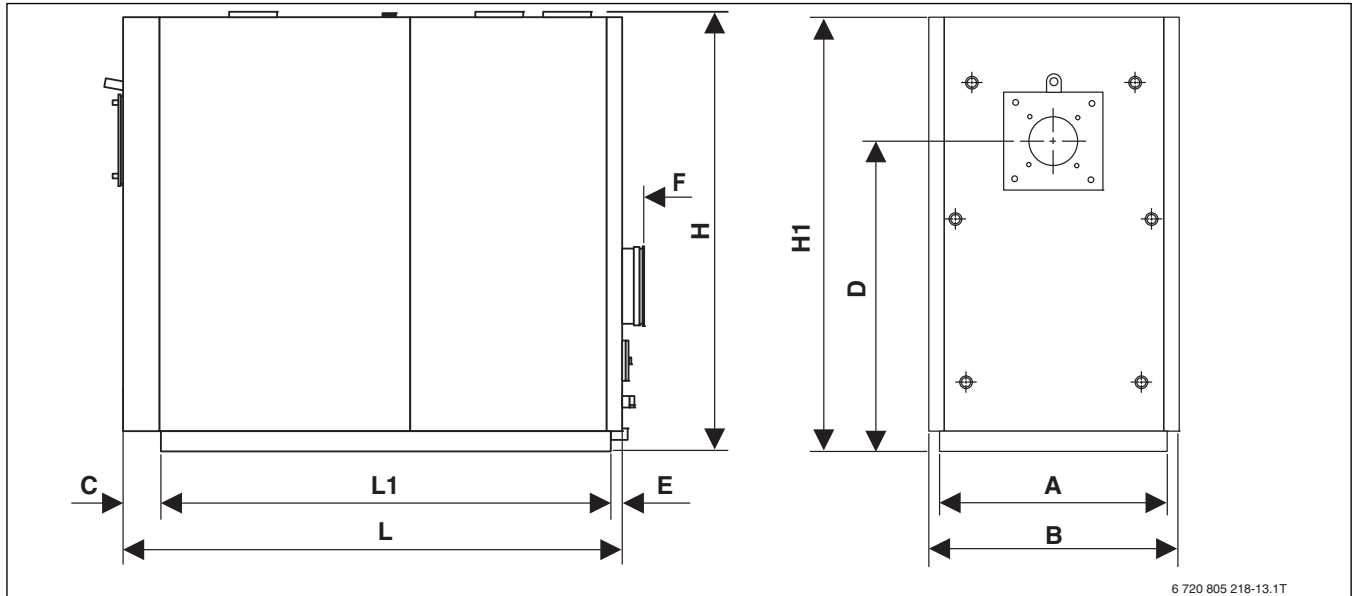

6 720 805 218-13.1T

Fig. 4 Dimensions

Description	Unit	SB625WS						SB745WS				
		160	220	290	370	480	640	800	1050	1300	1550	
A: Base width	inch (mm)	27 3/16 (690)	27 3/16 (690)	29 1/2 (750)	29 1/2 (750)	31 1/8 (790)	31 1/8 (790)	38 9/16 (980)	38 9/16 (980)	42 1/8 (1070)	44 1/2 (1130)	
B: Overall width	inch (mm)	29 15/16 (760)	29 15/16 (760)	32 5/16 (820)	32 5/16 (820)	35 1/16 (890)	35 1/16 (890)	42 1/2 (1080)	42 1/2 (1080)	46 1/16 (1170)	48 1/4 (1225)	
C: Length base to front	inch (mm)	4 3/4 (120)	4 3/4 (120)	4 15/16 (125)	4 15/16 (125)	5 1/8 (130)	5 1/8 (130)	5 1/2 (140)	5 1/2 (140)	6 1/8 (155)	5 7/8 (150)	
D: Height of burner plate	inch (mm)	37 3/8 (950)	37 3/8 (950)	40 9/16 (1030)	40 9/16 (1030)	48 5/8 (1235)	48 5/8 (1235)	54 3/4 (1390)	54 3/4 (1390)	58 7/8 (1495)	62 5/8 (1590)	
E: Length base to rear	inch (mm)	1 3/16 (30)	1 3/16 (30)	1 9/16 (40)	1 9/16 (40)	1 3/8 (35)	1 3/8 (35)	2 3/4 (70)	2 3/4 (70)	3 1/8 (80)	3 15/16 (100)	
F: Flue connection depth	inch (mm)	1 15/16 (50)	1 15/16 (50)	2 3/8 (60)	2 3/8 (60)	3 1/8 (80)	3 1/8 (80)	3 9/16 (90)	3 9/16 (90)	3 1/8 (80)	3 1/8 (80)	
H – Height of water fittings	inch (mm)	52 3/4 (1340)	52 3/4 (1340)	57 1/16 (1450)	57 1/16 (1450)	66 3/4 (1695)	66 3/4 (1695)	75 (1905)	75 (1905)	80 5/16 (2040)	85 13/16 (2180)	
H1 – Boiler height	inch (mm)	51 3/4 (1315)	51 3/4 (1315)	56 9/16 (1435)	56 9/16 (1435)	66 1/8 (1680)	66 1/8 (1680)	74 7/16 (1890)	74 7/16 (1890)	79 3/4 (2025)	85 1/4 (2165)	
L – Length	inch (mm)	57 5/16 (1455)	57 5/16 (1455)	65 3/16 (1655)	73 1/16 (1855)	80 1/8 (2035)	88 (2235)	103 1/8 (2620)	113 (2870)	120 11/16 (3065)	121 1/4 (3080)	
L1 – Base length	inch (mm)	51 3/8 (1305)	51 3/8 (1305)	58 11/16 (1490)	66 9/16 (1690)	73 7/16 (1865)	81 1/2 (2070)	94 7/8 (2410)	104 3/4 (2660)	111 7/16 (2830)	111 7/16 (2830)	
Weight of boiler	lbs (kg)	22 5/8 (575)	23 1/4 (590)	29 15/16 (760)	31 7/8 (810)	48 5/8 (1235)	52 15/16 (1345)	74 7/16 (1890)	85 5/16 (2167)	105 1/2 (2680)	122 1/16 (3100)	
Weight of paneling	lbs (kg)	110 (50)	110 (50)	132 (60)	154 (70)	198 (90)	264 (120)	308 (140)	352 (160)	473 (215)	506 (230)	

Table 4 Technical Data

2.9.2 Technical Data

Description	Unit	SB625WS						SB745WS			
		160	220	290	370	480	640	800	1050	1300	1550
Fuel		Gas	Gas	Gas	Gas	Gas	Gas	Gas	Gas	Gas	Gas
Rated input (Nat. Gas)	MBH (kW)	563 (164.9)	788 (230.9)	1014 (297.1)	1314 (385.0)	1689 (494.9)	2200 (644.7)	3003 (880.0)	3754 (1100.0)	4692 (1375.0)	5443 (1595.0)
Rated input (#2 Oil)	GPH (LPH)	4.0 (15.1)	5.6 (21.2)	7.2 (27.3)	9.3 (35.2)	12.0 (45.4)	15.7 (59.4)	21.4 (81.0)	26.8 (101.4)	33.5 (126.8)	38.8 (146.9)
Gross output	MBH (kW)	532 (159.7)	745 (218.2)	959 (280.9)	1243 (364.1)	1598 (468.1)	2081 (609.5)	2846 (833.0)	3529 (1033.7)	4364 (1278.3)	5029 (1473.1)
Sensible losses from stack	%	1.7	1.7	1.5	1.5	1.9	1.9	1.9	1.9	1.9	1.9
Jacket losses with burner mounted	%	0.3	0.3	0.5	0.6	0.6	0.6	0.6	0.6	0.6	0.6
Flue gas temperature (ΔT)	$^{\circ}F$ ($^{\circ}C$)	< 113 - 167 (< 45 - 75)		< 113 - 167 (< 45 - 75)		< 113 - 167 (< 45 - 75)		< 113 - 167 (< 45 - 75)		< 113 - 167 (< 45 - 75)	
Flue gas mass flow rate ¹	lbs/sec (kg/sec)	0.15 (0.07)	0.19 (0.09)	0.26 (0.12)	0.33 (0.15)	0.44 (0.20)	0.57 (0.26)	0.72 (0.33)	0.94 (0.43)	1.19 (0.54)	1.38 (0.63)
Fireside pressure drop ²	Inch W.C (mbar)	0.802 (2.0)	1.083 (2.7)	1.284 (3.2)	1.846 (4.6)	2.007 (5.0)	2.208 (5.5)	2.288 (5.7)	2.529 (6.3)	2.729 (6.8)	2.970 (7.4)
Firebox volume	Ft ³ (dm ³)	6.07 (172)	6.07 (172)	8.51 (241)	9.85 (279)	15.61 (442)	17.51 (496)	26.59 (753)	30.15 (854)	36.62 (1037)	44.10 (1249)
Total volume of flue gas side	Ft ³ (dm ³)	8.93 (253)	9.78 (277)	14.58 (413)	17.02 (482)	26.03 (737)	30.37 (860)	45.55 (1290)	51.34 (1454)	62.25 (1763)	74.05 (2097)
Heat exchanger surface area	Ft ² (m ²)	65.65 (6.1)	94.72 (8.8)	139.93 (13.0)	175.45 (16.3)	234.65 (21.8)	310.00 (28.8)	426.25 (39.6)	500.52 (46.5)	604.93 (56.2)	670.37 (62.2)
Specific heat load	MBH/ft ² (kW/m ²)	8.28 (26.18)	8.04 (25.40)	7.07 (22.32)	7.29 (23.01)	6.99 (22.08)	7.06 (22.29)	6.42 (20.26)	7.29 (23.01)	7.54 (23.79)	7.89 (24.94)
Maximum condensate production	Gal/h (l/h)	4.86 (18.4)	7.23 (27.4)	8.42 (31.9)	10.80 (40.9)	13.78 (52.2)	19.49 (73.8)	23.24 (88.0)	29.42 (111.4)	35.05 (132.7)	42.13 (159.5)
Maximum working pressure	PSI (bar)	80 (5.5)	80 (5.5)	80 (5.5)	80 (5.5)	80 (5.5)	80 (5.5)	80 (5.5)	80 (5.5)	80 (5.5)	80 (5.5)
Maximum admissible temperature	$^{\circ}F$ ($^{\circ}C$)	230 (110)	230 (110)	230 (110)	230 (110)	230 (110)	230 (110)	230 (110)	230 (110)	230 (110)	230 (110)
Maximum working temperature	$^{\circ}F$ ($^{\circ}C$)	210 (98.8)	210 (98.8)	210 (98.8)	210 (98.8)	210 (98.8)	210 (98.8)	210 (98.8)	210 (98.8)	210 (98.8)	210 (98.8)
Pressure drop ΔT 18 $^{\circ}F$ (10 $^{\circ}C$)	Ft. Hd. (mbar)	5.0 (150.1)	3.3 (100.4)	4.1 (121.5)	4.3 (128.7)	1.0 (30.2)	1.1 (33.8)	1.5 (46.4)	1.8 (54.0)	1.2 (36.0)	1.4 (43.2)
Pressure drop ΔT 36 $^{\circ}F$ (20 $^{\circ}C$)	Ft. Hd. (mbar)	1.2 (36.3)	0.9 (28.4)	1.0 (30.6)	0.9 (28.7)	0.3 (8.5)	0.3 (9.0)	0.4 (13.4)	0.5 (16.3)	0.3 (10.2)	0.4 (11.3)
Water capacity	Gal (l)	85.3 (323)	95.1 (360)	130.7 (495)	146.6 (555)	196.2 (743)	203.4 (770)	348.7 (1320)	368.5 (1395)	482.1 (1825)	501.9 (1900)

Table 5 Technical Data

1. Depends on return temperature 86-140 $^{\circ}F$ (30-60 $^{\circ}C$)
2. At maximum output with water temps supply/return of 176/140 $^{\circ}F$ (80/60 $^{\circ}C$) and CO₂ = 9.7 %

2.9.3 Water connections

The boilers are designed and made for use in central heating installations, but can also be used for domestic hot water production if

connected to suitable sub-systems. Water fittings are as specified in the following table.

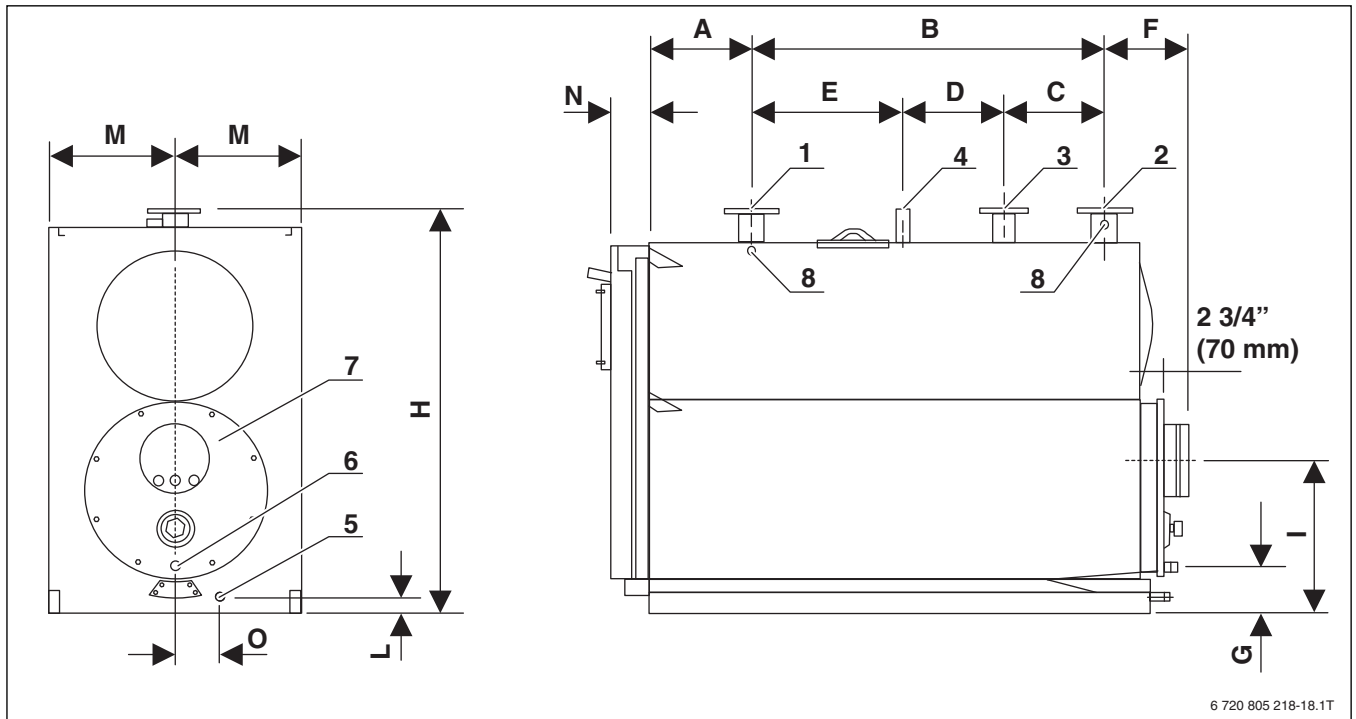

Fig. 5 Water connections - SB625WS/160-640 and SB745/800-1300

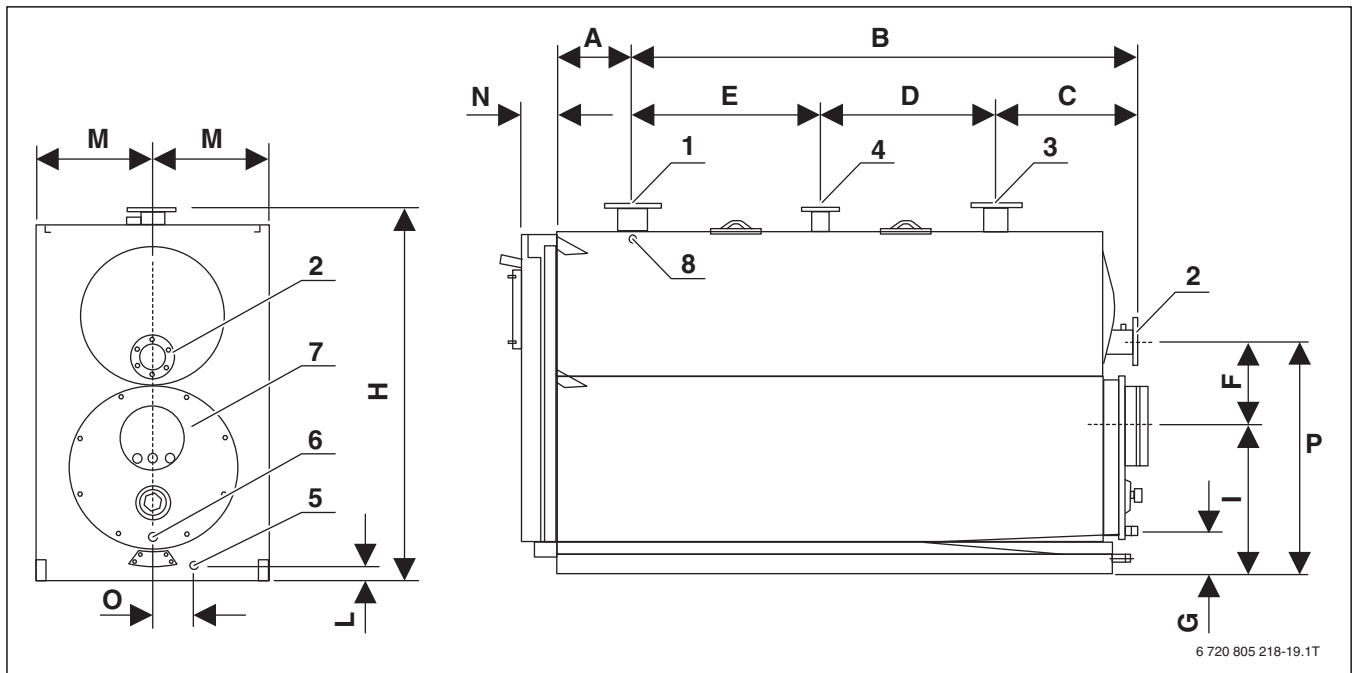

Fig. 6 Water connections - SB745WS/1550



The choice of system components and the method of their installation are left up to the installer. Installers must use their expertise to ensure proper installation and functioning in compliance with all applicable codes.

Description	Unit	SB625WS						SB745WS			
		160	220	290	370	480	640	800	1050	1300	1550
1 – Heating supply	inch (DN)	2 1/2 (65)	2 1/2 (65)	2 1/2 (65)	3 (80)	4 (100)	4 (100)	5 (125)	5 (125)	6 (150)	6 (150)
2 – Heating return 1 (Low Temperature)	inch (DN)	2 1/2 (65)	2 1/2 (65)	2 1/2 (65)	3 (80)	4 (100)	4 (100)	5 (125)	5 (125)	6 (150)	6 (150)
3 – Heating return 2 (High Temperature)	inch (DN)	2 (50)	2 (50)	2 (50)	2 1/2 (65)	3 (80)	3 (80)	3 (80)	3 (80)	4 (100)	4 (100)
4 – Safety device fitting	inch (DN)	1 1/4	1 1/4	1 1/4	1 1/4	1 1/2	1 1/2	3 (80)	3 (80)	3 (80)	3 (80)
5 – Boiler drain fitting	Ø - inch	1	1	1	1	1	1	1 1/4	1 1/4	1 1/4	1 1/4
6 – Condensate drain fitting	Ø - inch	1	1	1	1	1 1/4	1 1/4	1 1/4	1 1/4	1 1/4	1 1/4
7 – Flue gas exhaust fitting	Ø mm	200	200	250	250	300	300	350	350	400	450
8 – Instrument bulb/probe sockets	n° x Ø"	3 x 1/2	3 x 1/2	3 x 1/2	3 x 1/2	3 x 1/2	3 x 1/2	3 x 1/2	3 x 1/2	3 x 1/2	3 x 1/2
A – Distance from burner head to heating supply	inch (mm)	11 7/8 (302)	11 7/8 (302)	12 1/16 (306)	12 5/8 (321)	12 1/4 (311)	12 1/4 (311)	16 1/8 (410)	16 1/8 (410)	17 5/16 (440)	17 3/8 (442)
B – Distance from heating flow outlet to return 1	inch (mm)	34 7/8 (885)	34 7/8 (885)	41 3/8 (1050)	48 5/16 (1235)	55 5/16 (1405)	63 3/16 (1605)	70 7/8 (1800)	80 11/16 (2050)	86 5/8 (2200)	101 3/4 (2582)
C – Distance between heating returns 1 & 2	inch (mm)	7 7/8 (200)	7 7/8 (200)	11 13/16 (300)	9 7/8 (250)	10 1/8 (255)	11 13/16 (300)	13 13/16 (350)	13 13/16 (350)	13 13/16 (350)	28 13/16 (732)
D – Distance between heating return 2 and safety device fitting	inch (mm)	11 1/4 (285)	11 1/4 (285)	11 13/16 (300)	17 3/4 (450)	23 5/8 (600)	27 9/16 (700)	29 1/2 (750)	33 1/2 (850)	33 1/2 (850)	33 1/2 (850)
E – Distance between heating flow outlet and safety device fitting	inch (mm)	15 3/4 (400)	15 3/4 (400)	17 3/4 (450)	21 1/16 (535)	21 11/16 (550)	23 13/16 (605)	27 9/16 (700)	33 1/2 (850)	39 3/8 (1000)	39 3/8 (1000)
F – Distance between heating return 1 and flue gas outlet	inch (mm)	7 7/8 (200)	7 7/8 (200)	9 1/2 (242)	9 1/2 (242)	10 5/8 (270)	10 5/8 (270)	12 13/16 (325)	12 13/16 (325)	13 3/4 (350)	22 1/4 (565)
G – Height of condensate drain	inch (mm)	6 5/16 (160)	6 5/16 (160)	6 1/8 (155)	6 1/8 (155)	8 1/2 (215)	8 1/2 (215)	7 11/16 (195)	7 11/16 (195)	8 7/16 (215)	9 1/4 (235)
H – Height of boiler flanges	inch (mm)	52 3/4 (1340)	52 3/4 (1340)	57 1/16 (1450)	57 1/16 (1450)	66 3/4 (1695)	66 3/4 (1695)	75 (1905)	75 (1905)	80 5/16 (2040)	85 13/16 (2180)
I – Height of flue gas outlet	inch (mm)	19 7/8 (505)	19 7/8 (505)	21 1/16 (535)	21 1/16 (535)	25 (635)	25 (635)	26 3/4 (680)	26 3/4 (680)	28 3/8 (720)	31 11/16 (805)
L – Height of boiler drain fitting	inch (mm)	2 3/8 (60)	2 3/8 (60)	2 7/16 (61)	2 7/16 (61)	3 1/4 (82)	3 1/4 (82)	3 3/8 (86)	3 3/8 (86)	3 1/2 (90)	3 3/8 (85)
M – Boiler centerline	inch (mm)	13 9/16 (345)	13 9/16 (345)	14 9/16 (375)	14 9/16 (375)	15 9/16 (395)	15 9/16 (395)	19 5/16 (490)	19 5/16 (490)	21 1/16 (535)	22 1/4 (565)
O – Distance from Boiler drain fitting	inch (mm)	5 3/16 (132)	5 3/16 (132)	5 3/8 (137)	5 3/8 (137)	4 15/16 (125)	4 15/16 (125)	6 7/8 (175)	6 7/8 (175)	7 1/8 (181)	7 (178)
P – Height of heating return 1 (Low Temperature)	inch (mm)	-	-	-	-	-	-	-	-	-	53 7/8 (1370)

Table 6 Technical Data

3 Water treatment

The quality of the fill and top-up water is an essential factor for increased efficiency, functional reliability, long service life and for maintaining the constant operational condition of a heating system. If the system is filled with water that has a high calcium hardness, this will be deposited on the heat exchanger surfaces and will obstruct the transfer of heat to the heating water.

As a result, the wall temperatures of the stainless steel heat exchanger surfaces will increase and the thermal stress (loads on the boiler body) will increase. Water treatment is an essential factor in ensuring trouble free operation, availability, a long service life and the efficiency of the heating system.

NOTICE:

If it proves impossible to treat the heating system water supply properly because the water charging system is automatic and uncontrolled, if there are no barriers installed to prevent water oxygenation, and if the heating system includes an open expansion vessel, then the boiler itself must be separated from the heating system by means of a heat exchanger.



Installation must conform to any and all national, federal, state and local standards and codes.

3.1 Chemical and physical characteristics

The chemical and physical characteristics of heating system water must be similar to those of drinking water.

A chemical water treatment device is recommended in order to protect system components as well as an inlet filter to prevent solid particles from entering the system in suspension and causing corrosion or sludge.

Typical layouts of water treatment systems

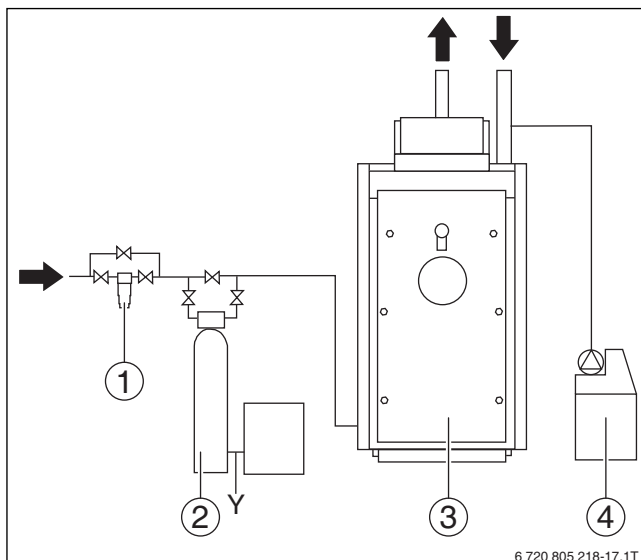

Fig. 7 Water treatment for heating installations

- [1] Filter
- [2] Water softener
- [3] Boiler
- [4] Chemical treatment unit

Chemical and physical requirements of heating system water

Parameters	Unit	Heating water
pH		7.5- 9,5
Hardness	ppm	< 50
Electrical conductivity	µs/cm	< 100
Chlorides	mg/l	< 10
Sulphides	mg/l	< 10
Nitrides	mg/l	< 10
Oxygen in solution	mg/l	–
Iron (Fe)	mg/l	< 0.5

Table 7 Requirements of heating system water

NOTICE:

Chemical products used for water treatment must be compatible with applicable water pollution laws. Provided they are properly applied, these laws guarantee the safe functioning of the heating system.

3.2 Central heating system

Possible causes for corrosion and limescale

Typical problems encountered in central heating systems include:

- the breakage of heated surfaces through overheating caused by the thermal insulation of limescale deposits on the water side
- oxygen corrosion
- deposit corrosion
- stray current corrosion
- diffused and localized acid corrosion.

3.2.1 Limescale deposits

Limescale forms when the calcium and magnesium bicarbonates that are dissolved in the water at ambient temperature become chemically transformed when the water is heated.

Calcium bicarbonate forms calcium carbonate, water and carbon dioxide, while magnesium bicarbonate transforms into magnesium hydroxide and carbon dioxide.

Calcium bicarbonate $\text{Ca}(\text{HCO}_3)_2$

when temperature is increased:

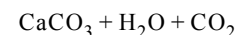

F. 1 Calcium bicarbonate changes when temperature is increased

Magnesium bicarbonate $\text{Mg}(\text{HCO}_3)_2$

when temperature is increased:

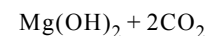

F. 2 Magnesium bicarbonate changes when temperature is increased

Calcium carbonate and magnesium hydroxide precipitate to form insoluble deposits that adhere and compact on surfaces to form limescale, a substance with a high thermal insulating power.

Inside a boiler, limescale forms mainly in areas subject to direct heat and high temperatures. It is so common to find deposits localized in a few specific areas, where temperature is the highest. A coating of limescale

of only 1 mm can cause severe overheating in metal parts and consequent damage through thermal stress. It is continuous topping up (automatic fill from incoming water) that causes thick deposits to form, leading to boiler breakdown.

3.2.2 Deposit corrosion

Deposit corrosion is an electro-chemical phenomenon caused by the presence of foreign bodies (sand, rust, etc.) in the water mass. These solid substances generally form deposits (sludge) in the bottom of the boiler.

The lower parts of the boiler can therefore be affected by a chemical reaction of micro-corrosion caused by the electrochemical potential difference created between the metal (steel) and the impurities around it.

3.2.3 Stray current corrosion

Stray current corrosion is not common, but can be caused by the different electrical potentials of the boiler water and the metal body of the boiler or piping creating a cathode/anode effect.

All metal parts of the boiler should therefore be connected to an efficient ground (earth) point, even though this form of corrosion is actually caused by the passage of DC current, no longer used for domestic power. Stray current corrosion is easily identified by the regular tiny conical holes it leaves.

3.2.4 Diffused and localized acid corrosion

Other forms of corrosion exist that are harder to see but nonetheless dangerous because they affect the entire heating system and not just the boiler.

These forms of corrosion are generally due to the water becoming acidic (pH < 7), and are caused by:

- Incorrect water softening and the presence of carbon dioxide (which lowers the water's pH). Carbon dioxide is released more easily in softened water and also forms during the limescale formation process. Acid corrosion is diffused and attacks the entire system more or less uniformly
- Incorrect acid washing (e.g. washing done without a passivating agent). Acid introduced into the system can cause localized perforation if it is not properly removed from all parts of the system. The formation of corrosion can easily be detected by analyzing the chemical composition of the water. Even a minimal iron content is a clear sign that corrosion is occurring.



The technical details provided in this section refer specifically to domestic and industrial hot water heating systems with working temperatures up to 210 °F (98,8 °C).

3.3 New central heating systems

Mistakes to avoid and precautions.

To eliminate contact between system water and the air, the following is required:

- ensure that the expansion vessel is a closed vessel, and of the correct size and pre-charge pressure (the pressure should be checked periodically)
- ensure that the system is always kept at a pressure higher than atmospheric pressure at all points (including the pump suction side) and at all operating conditions (precisely because the seals, gaskets and joints in a water circuit are designed to resist pressure from within, but not to resist a vacuum within)

- ensure that no part of the system is made from materials that are permeable to gases (e.g. plastic pipes with no oxygen barrier used in floor heating systems).

NOTICE:

The original system filling water and any topping up water must always be filtered (using synthetic or metal mesh filters with a filtration rating of no less than 50 microns) to prevent sludge from forming and triggering deposit induced corrosion.

NOTICE:

Loss of water from the system, and the consequential need to add water, can be caused not only by leaks from the circuit, but also from the incorrect sizing of the expansion vessel or precharge pressure. (If normal thermal expansion causes pressure in the system to increase beyond the setting of the safety valve, that safety valve will open continuously.) The expansion vessel size should be corrected to prevent unnecessary safety valve blow-off.

The heating system should not need any further topping up once it is filled and bled of all air.

Any top-ups need to be monitored (by a meter), treated and recorded in the heating system's technical log. The presence of a water softener in conjunction with an automatic filling system is not sufficient to ensure proper performance.

If more than one boiler is installed in a large system, all boilers must be switched on at the same time to ensure that any possible limescale formation is uniformly distributed.

3.4 Reconditioning old heating systems

Frequent mistakes and necessary precautions.

If a boiler must be replaced, do not refill the entire central heating circuit if the quality of water in it conforms to requirements.

If the quality of water fails to conform to requirements, either recondition the old water or separate the water circuits (water in the boiler circuit must conform to requirements).

Conclusions

Never forget that proper water conditioning and proper heating system design not only guarantee safety and security but also ensures significant savings in maintenance costs and overall thermal efficiency.

3.5 Elimination air and gas from central heating system

When designing new heating systems, it is necessary to eliminate the air and other gases that form in the system.

Recently added fill or top-up water loses much of its volume in the first few days because it releases gases. With new systems you should therefore initially check the heating water pressure on a daily basis, and then at gradually longer intervals. Air and gas in the water system not only causes the corrosion problems listed above, but also reduces thermal efficiency, causing pump failure and noise and vibration throughout the heating system. Air bubbles and gas inevitably form in heating circuits during normal functioning, especially if the precautions listed above are not fully respected.

In particular:

- as temperature increases, oxygen becomes less watersoluble and bubbles begin to form.

- CO₂ (carbon dioxide) is generated as the carbonates of calcium and magnesium precipitate out.
- the chemical oxidation of the metals in the system also generates hydrogen.

These gases must be eliminated as they are formed. The system needs to be designed and installed so that all gases can be vented quickly, easily, and effectively.

3.6 Use of Antifreeze



Do not use automotive silicate-based antifreeze in the heating system.

In areas where freezing may occur, an antifreeze may be added to the system water as protection. Please adhere to the specifications provided by the antifreeze manufacturer.

- ▶ Use the anti-freeze manufacturer's data to determine the anti-freeze ratio for the desired freeze protection temperature.
- ▶ Do not exceed 50% antifreeze mix ratio and do not use antifreeze other than specifically made for hot water heating systems.

4 Transport



WARNING: Risk of injury from carrying heavy loads and inadequately securing loads for transport.

- ▶ Use suitable means of transportation, e.g. several pallet trucks, a forklift truck, crane or heavy duty rollers.
- ▶ Secure the load against falling.

- ▶ Only use lifting equipment of adequate capacity.
- ▶ Remove the transport straps and the wooden pallet before positioning the boiler.
- ▶ For lifting using a rigging crane, use only the lifting provisions supplied.
- ▶ When lifting the boiler using chains, make sure that at least two chains are load-bearing. Lift up very carefully.
- ▶ Maintain less than a 45 degree angle with the vertical when lifting the boiler with chains or cables.
- ▶ The rigging crane must be operated by trained personnel.



Never pull retaining straps (fixing straps, chains) over the boiler insulation.

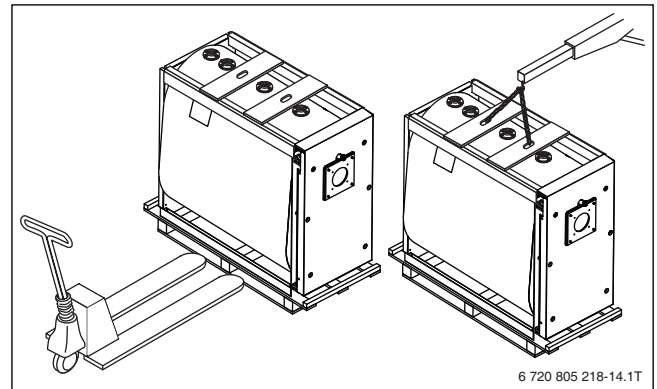

6 720 805 218-14.1T

Fig. 8 Transport

5 Installation

5.1 Boiler Clearances

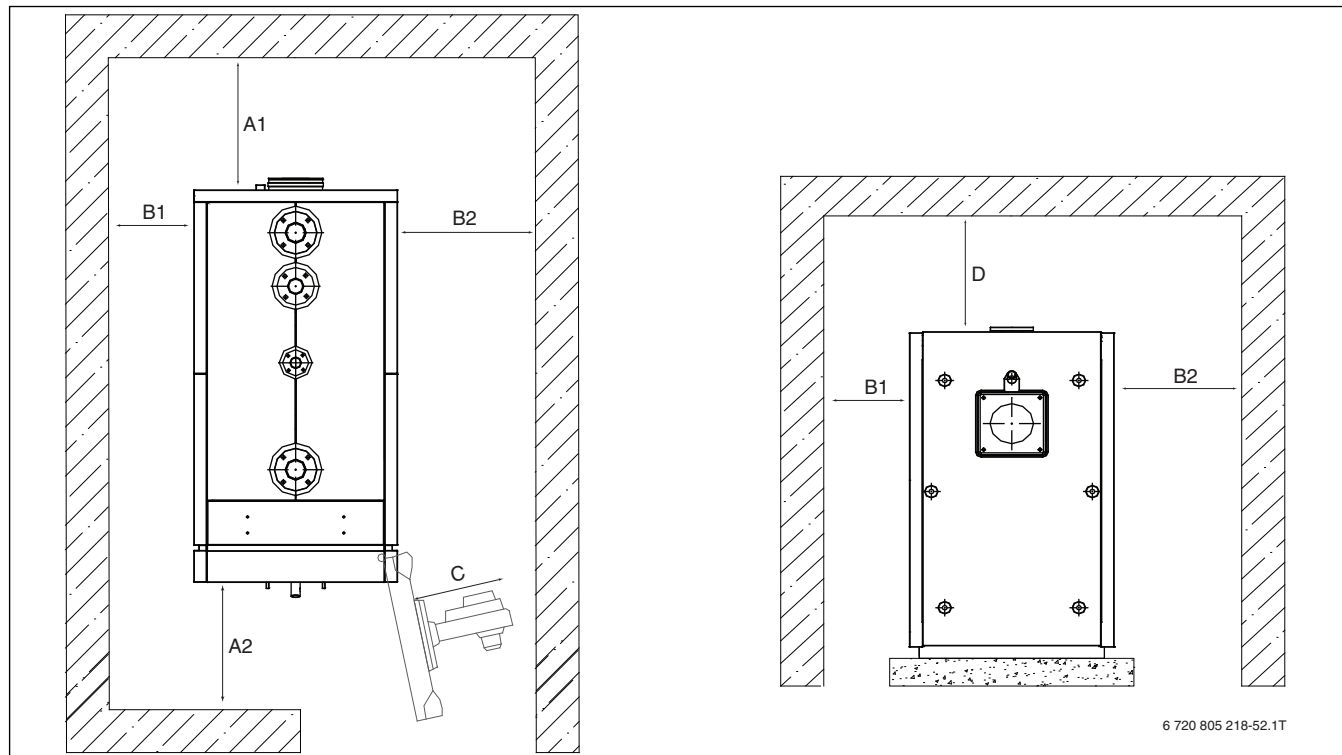

Fig. 9 Installation site

NOTICE: Risk of system damage through frost.

- ▶ Do not install the boiler outdoors; it is not designed to work outdoors and is not fitted with the necessary automatic anti-frost systems to do so.
- ▶ Ensure that the boiler installation room remains free from the risk of frost.

Installation room requirements:

In the boiler installation room, an ambient temperature of between 32 °F and 95 °F (0 °C and 35 °C) must be ensured.

The boilers must be installed in a dedicated boiler room, with adequately sized vents, in compliance with applicable codes and standards.

If at all possible, the boiler should be installed on a raised base to prevent the burner fan from drawing in dust and to facilitate draining of condensate to a neutralization system. The boiler base must be flat and levelled.

The boiler condensate drain must be located above the height of the lid of the system's condensate neutralizer.

The gas supply pipe should be installed in such away that the boiler's paneling can be removed and the front door opened without having to remove the burner.

	Unit	SB625WS						SB745WS			
		160	220	290	370	480	640	800	1050	1300	1550
Recommended Service											
A1	inch (mm)	36,00 (915)	36,00 (915)	36,00 (915)	36,00 (915)	36,00 (915)	36,00 (915)	36,00 (915)	36,00 (915)	36,00 (915)	36,00 (915)
A2	inch (mm)	64,00 (1626)	64,00 (1626)	65,00 (1630)	73,00 (1830)	81,00 (2035)	88,00 (2235)	101,00 (2560)	111,00 (2810)	119,00 (3010)	122,00 (3080)
B1	inch (mm)	36,00 (915)	36,00 (915)	36,00 (915)	36,00 (915)	36,00 (915)	36,00 (915)	36,00 (915)	36,00 (915)	36,00 (915)	36,00 (915)
B2	inch (mm)	36,00 (915)	36,00 (915)	36,00 (915)	36,00 (915)	36,00 (915)	36,00 (915)	36,00 (915)	36,00 (915)	36,00 (915)	36,00 (915)
D	inch (mm)	36,00 (915)	36,00 (915)	36,00 (915)	36,00 (915)	36,00 (915)	36,00 (915)	36,00 (915)	36,00 (915)	36,00 (915)	36,00 (915)
Minimum Service											
A1	inch (mm)	24,00 (610)	24,00 (610)	24,00 (610)	24,00 (610)	24,00 (610)	24,00 (610)	24,00 (610)	24,00 (610)	24,00 (610)	24,00 (610)
A2	inch (mm)	64,00 (1626)	64,00 (1626)	64,00 (1626)	64,00 (1626)	64,00 (1626)	64,00 (1626)	64,00 (1626)	64,00 (1626)	64,00 (1626)	64,00 (1626)
B1	inch (mm)	18,00 (457)	18,00 (457)	18,00 (457)	18,00 (457)	18,00 (457)	18,00 (457)	18,00 (457)	18,00 (457)	18,00 (457)	18,00 (457)
B2	inch (mm)	C+4 (C+100)	C+4 (C+100)	C+4 (C+100)	C+4 (C+100)	C+4 (C+100)	C+4 (C+100)	C+4 (C+100)	C+4 (C+100)	C+4 (C+100)	C+4 (C+100)
D	inch (mm)	18,00 (457)	18,00 (457)	18,00 (457)	18,00 (457)	18,00 (457)	18,00 (457)	18,00 (457)	18,00 (457)	18,00 (457)	18,00 (457)
Clearance to combustibles											
A1	inch (mm)	18,00 (457)	18,00 (457)	18,00 (457)	18,00 (457)	18,00 (457)	18,00 (457)	18,00 (457)	18,00 (457)	18,00 (457)	18,00 (457)
A2	inch (mm)	64,00 (1626)	64,00 (1626)	64,00 (1626)	64,00 (1626)	64,00 (1626)	64,00 (1626)	64,00 (1626)	64,00 (1626)	64,00 (1626)	64,00 (1626)
B1	inch (mm)	6,00 (152)	6,00 (152)	6,00 (152)	6,00 (152)	6,00 (152)	6,00 (152)	6,00 (152)	6,00 (152)	6,00 (152)	6,00 (152)
B2	inch (mm)	6,00 (152)	6,00 (152)	6,00 (152)	6,00 (152)	6,00 (152)	6,00 (152)	6,00 (152)	6,00 (152)	6,00 (152)	6,00 (152)
D	inch (mm)	18,00 (457)	18,00 (457)	18,00 (457)	18,00 (457)	18,00 (457)	18,00 (457)	18,00 (457)	18,00 (457)	18,00 (457)	18,00 (457)

Table 8 Boiler clearances

5.2 Assembling the paneling



Smaller models (160/220/290) have only two top panels, one over the right and one over the left of the boiler.



Control panel may be fitted on either side or top panel of boiler.

- ▶ Push out the pre-formed slots in the boiler's side panel [12] or [8] depending on installed control panel location.
 - ▶ Perforate the membranes of the control panel cable grommets. Route the electrical cables through them and insert the sensors in their wells.
 - ▶ Fix the control panel to the boiler casing using the screws provided.
 - ▶ Fit the front side panels [12] and [8] and rear side panels [14] and [6] over the boiler frame [10] and to the top side beams.
 - ▶ On models 800 to 1550, also fit side panels [13] and [7].
- ▶ Secure the side panels in place using the top cross beams [19] and the screws provided.
 - ▶ Fit the top rear panel [17], the bottom rear bracket [15] and then the bottom rear panels [16] and [18]. Fit the front top panel [5].
 - ▶ Fit the top panels [1], [2], [4] and [3].
 - ▶ Finally, fit the front trim panels [11] and [9].

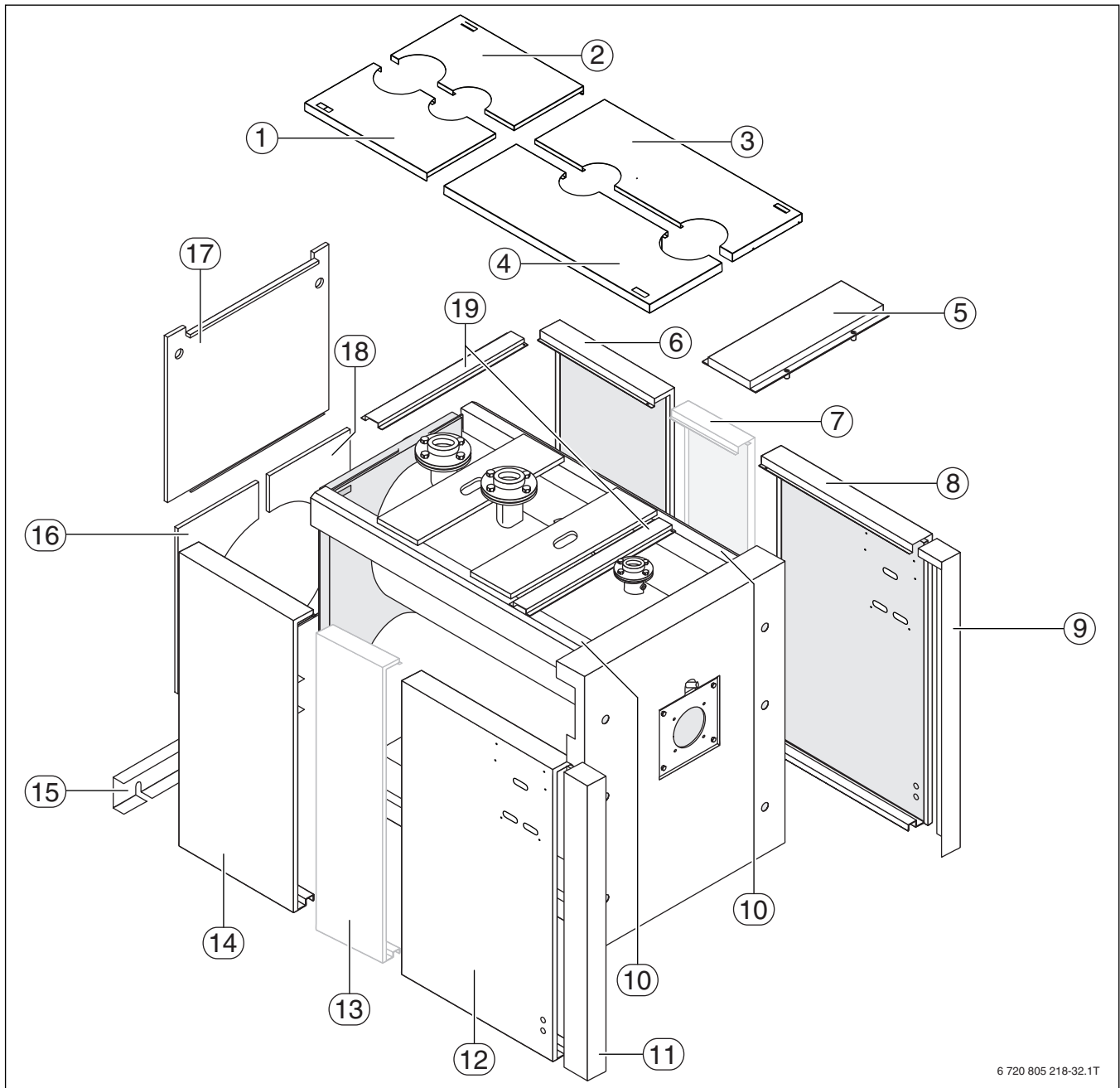

6 720 805 218-32.1T

Fig. 10 Paneling

- [1-4] Top panels
- [5] Front top panel
- [6] Rear side panel
- [7] Side panel
- [8] Front side panel
- [9] Front trim panel
- [10] Boiler frame
- [11] Front trim panel
- [12] Front side panel
- [13] Side panel
- [14] Rear side panel
- [15] Bottom rear bracket
- [16] Bottom rear panel
- [17] Top rear panel
- [18] Bottom rear panel

[19] Top cross beams

5.3 Refitting the door hinges

The boilers are pre-fitted with three hinges so that the opening direction of the door can be quickly reversed. Once you have checked that the default direction of opening is as required, or have reversed the direction of opening as instructed in section 5.3.1, remove the spare hinge assembly 'B' (screw, bushing and washer) opposite the pivot side of the door.

Two variations of door hinging systems have been used to satisfy varying constructional requirements:

- System A
 - on the smaller sizes
 - comes with a bracket and two hinge fixing nuts
- System B
 - on the larger sizes
 - comes with a hinge fixing plate, a nut and an internal compression spring.

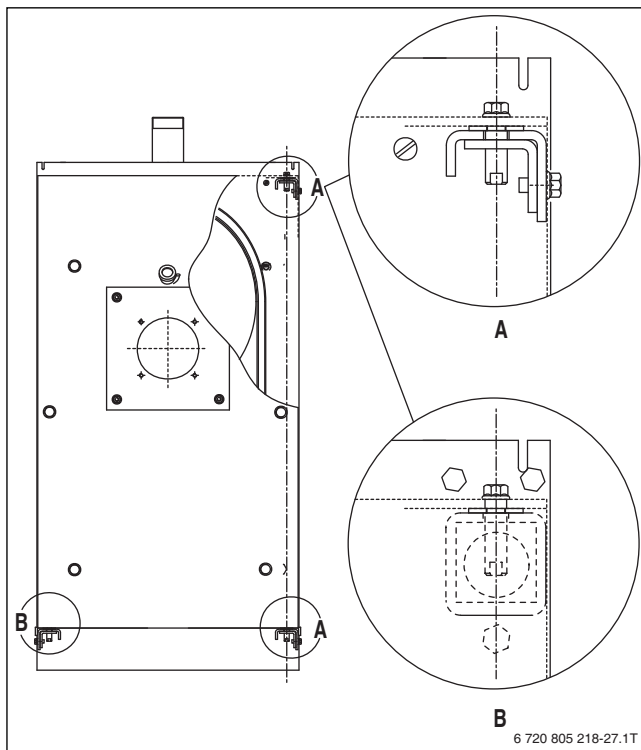

Fig. 11 Door hinging systems

5.3.1 Changing the direction of door opening

The boiler door hinges are factory fitted on the right of the door. If you need to reverse the direction of opening, remove the boiler's side panel and proceed as follows.

System A (smaller sizes)

- ▶ First ensure that the main door fixing bolts [1] are tight.
- ▶ Remove the safety bolts [2].

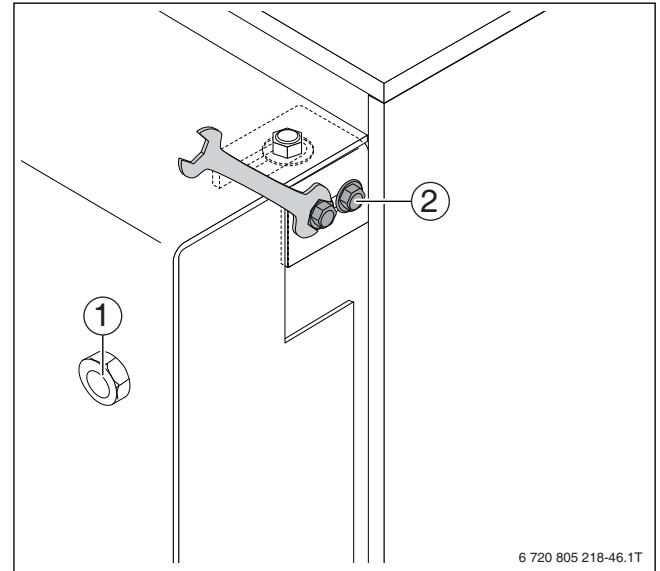

Fig. 12 Loosen safety bolts

- ▶ Lift off the door fixing brackets [3].

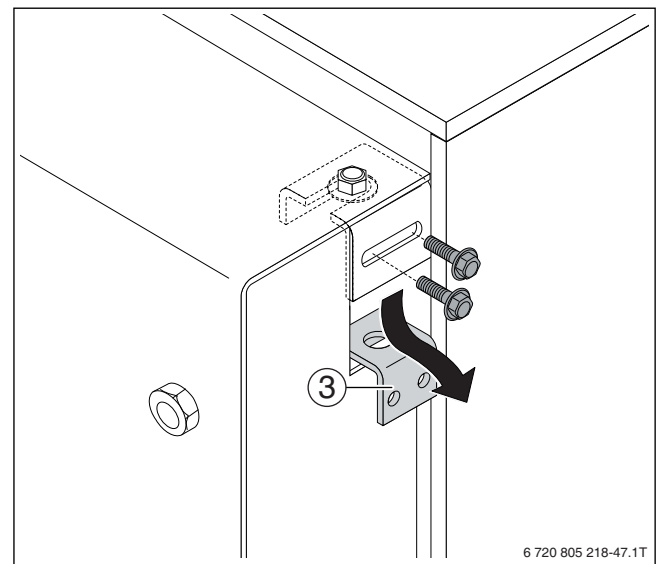

Fig. 13 Door fixing bracket

- ▶ Insert a wrench through the top slot and hold the bushing [4] steady.

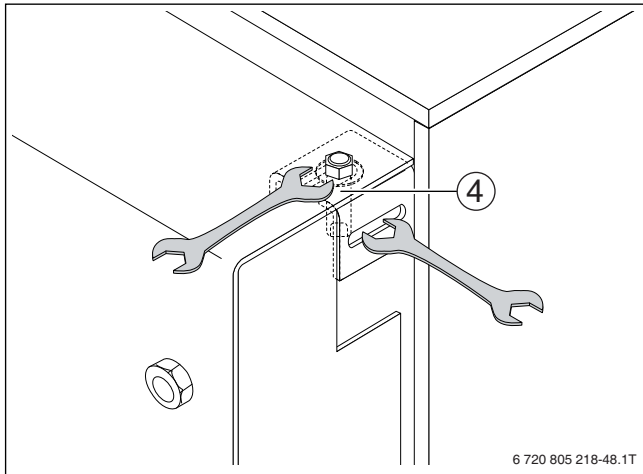

Fig. 14 Insert spanner

- ▶ Unscrew the top bolt [5].
- ▶ Remove the bushing [4] and washer [6].

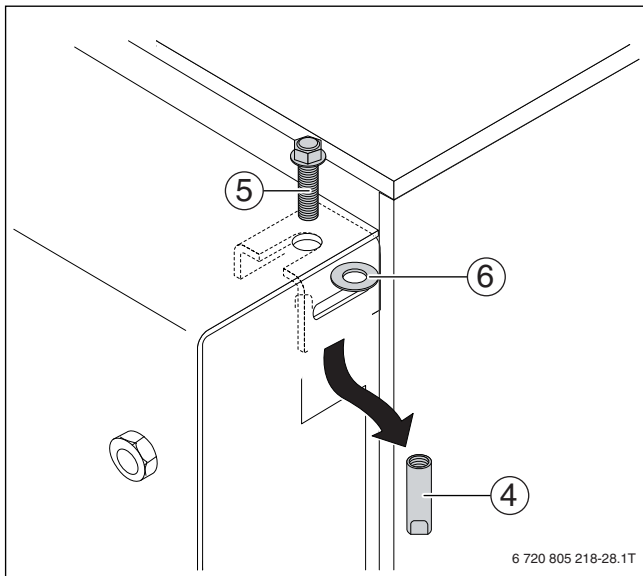

Fig. 15 Door hinging systems



Reverse the above steps to fit the door on the opposite side.

System B (larger sizes)

- ▶ Open the door.
- ▶ With the aid of a small hacksaw or a file remove the knockout on the side opposite the leading edge of the door (both top and bottom).

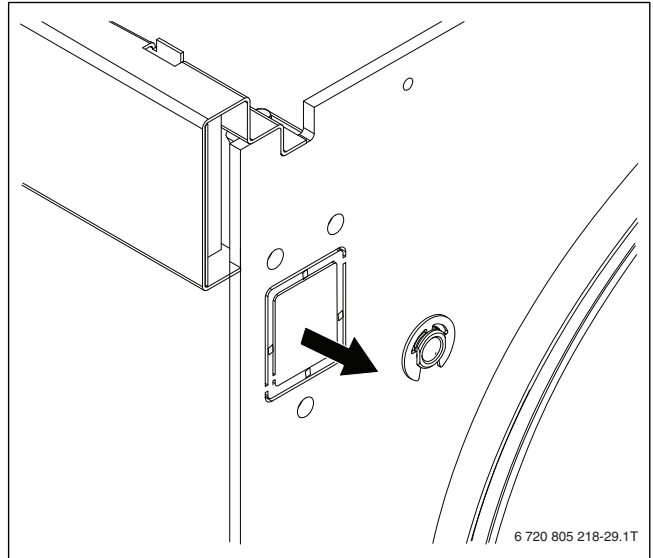

Fig. 16 Remove the knockout

- ▶ Seal the door by tightening the bolts [2] so that the door is self-supported by compression against the packing.

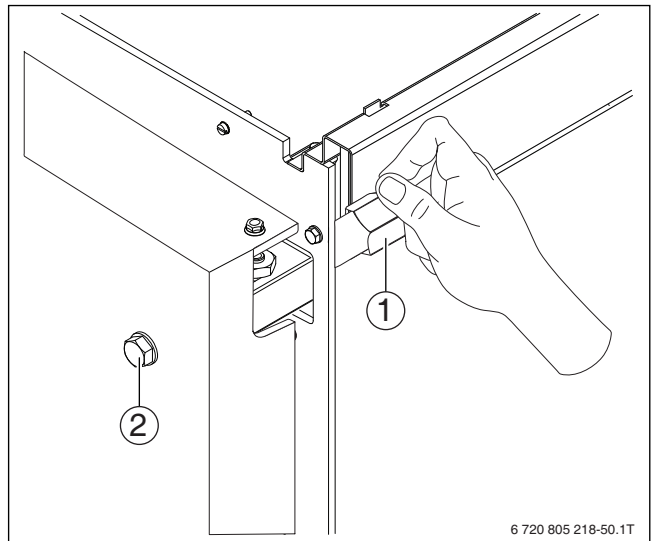
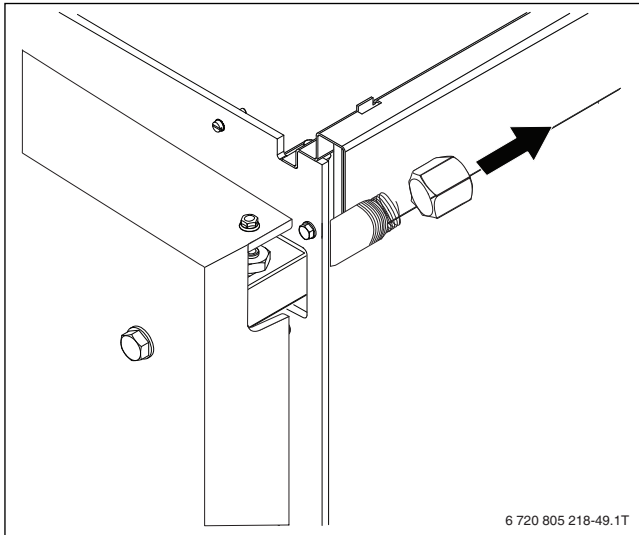

Fig. 17 Seal the door

- [1] Plug
- [2] Bolt

- ▶ Remove the plug taking care not to lose the compressed spring inserted in the threaded tube.



6 720 805 218-49.1T

Fig. 18 Remove the plug

- ▶ Remove the bolt [3] and the nuts [4].
- ▶ Remove the nuts [4] that secure the hinge plate [5] to the door
- ▶ Remove the plate.
- ▶ Remount the hinge plate on the opposite side, ensuring that the cylinder projecting above the nut [6] enters into its slot.
- ▶ If necessary tighten the nut [6] to raise it.
- ▶ Tighten the bolt [3].

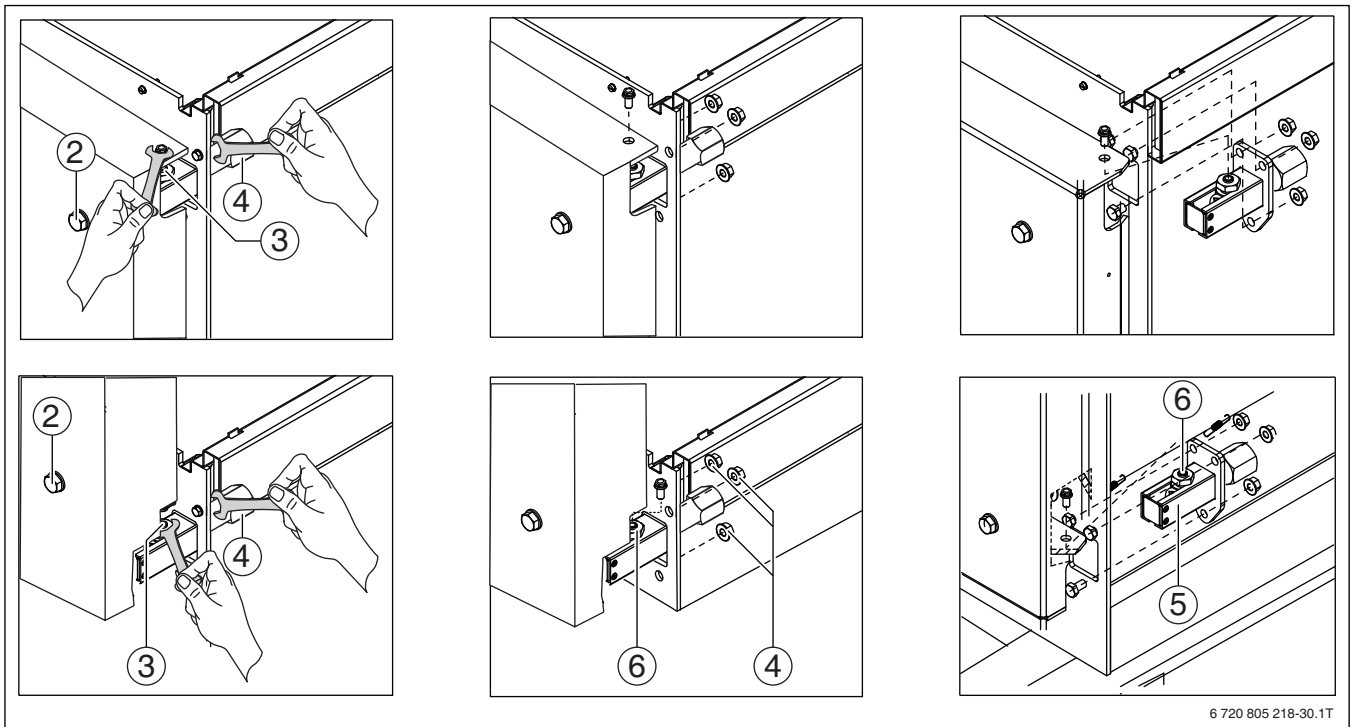

6 720 805 218-30.1T

Fig. 19 Changing the door opening (system B)

- [2] Bolt
- [3] Bolt
- [4] Nut
- [5] Hinge plate
- [6] Nut

5.3.2 Removing the hinge assembly “B”

- ▶ Ensure that the side safety bolt is tight.
- ▶ Remove the main fixing bolt.
- ▶ With the door open, remove the hinge assembly ‘B’ (bushing, bolt, and washer) opposite the pivot side of the door.

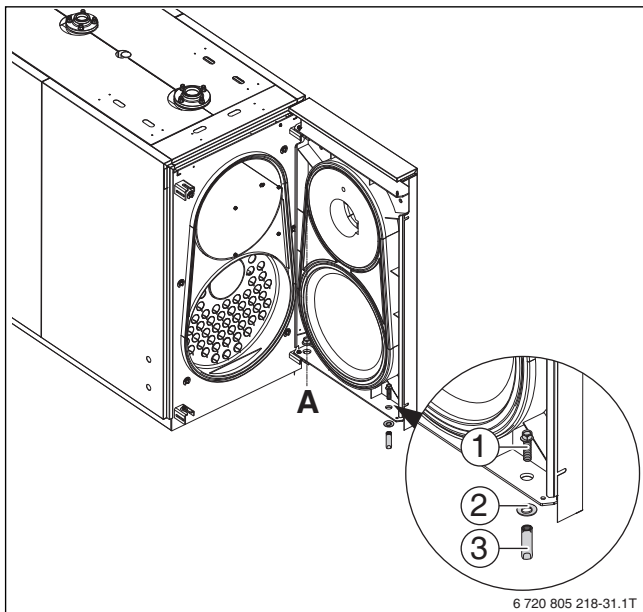

Fig. 20 Remove hinge assembly B

- [1] Bushing
- [2] Washer
- [3] Bolt

5.4 Burners

Installing the burner

Follow the burner manufacturer’s instructions when fitting the burner.



A pre-drilled burner plate is included with the boiler vessel.

An accessory plate may be required if a non-standard burner is used (see factory for details).

Follow the burner manufacturer’s instructions when fitting the burner.

As standard, the burner plate gasket must be trimmed in order to fit the burner blast tube. The installer must cut the hole 3/8" larger than the blast tube diameter.

The combustion chamber door must be opened to allow the burner to be mounted.

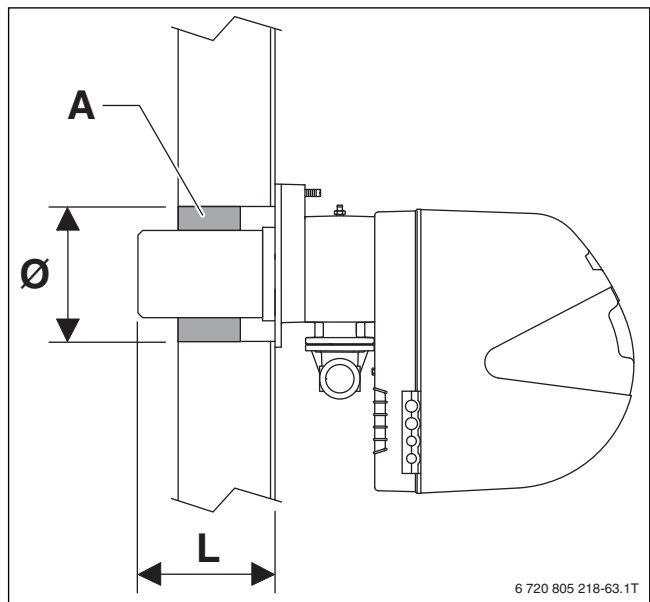

Fig. 21 Burner

- [A] Ceramic insulation (shipped loose)
- [L] Minimum length
- [Ø] Diameter



When you finish installing the burner, fill the gap between the burner tube and the refractory material in the door with the ceramic insulation (A) supplied with the boiler.

Model	SB625WS					SB745WS				
	160	220	290	370	480	640	800	1050	1300	1550
Min. L inch (mm)	6 5/16 (160)	6 11/16 (170)	7 1/16 (180)	7 1/16 (180)	7 11/16 (195)	7 7/8 (200)	7 7/8 (200)	7 7/8 (200)	8 1/16 (205)	8 1/16 (205)
DOOR HOLES Ø inch (mm)	7 1/2 (190)	7 1/2 (190)	8 7/8 (225)	8 7/8 (225)	10 1/4 (260)	10 1/4 (260)	10 1/4 (260)	10 1/4 (260)	12 3/16 (310)	12 3/16 (310)

Table 9 Installation dimensions

5.5 Combustion gas exhaust

The flue gas exhaust and stack connection must be made in compliance with applicable laws and standards, using heat resistant, condensate resistant and stress resistant rigid pipe and sealed joints.

The stack must be fitted with a condensate trap and drain and the flue gas exhaust pipe must be installed at a slope of at least 2° towards the boiler. All condensate should be treated through a neutralization media before being eliminated to the floor drain.

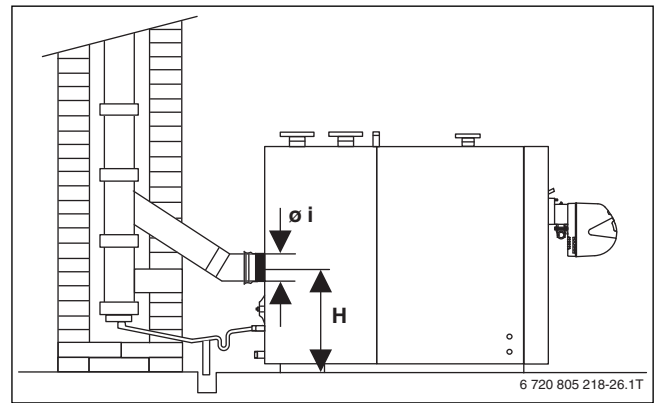

Fig. 22 Typical installation schematic

Description	Symbol	Unit	SB625WS						SB745WS			
			160	220	290	370	480	640	800	1050	1300	1550
Height of flue gas outlet	H	inch [mm]	19 7/8 (505)	19 7/8 (505)	21 1/6 (535)	21 1/6 (535)	25 (635)	25 (635)	26 3/4 (680)	26 3/4 (680)	28 3/8 (720)	31 11/18 (805)
Diameter of flue gas fitting	ø i	[mm]	200	200	250	250	300	300	350	350	400	450

Table 10 Combustion gas exhaust

5.6 Venting Requirements



WARNING: Risk of system damage or personal injury!

The vent system could fail, causing flue gas spillage, resulting in severe personal injury or death.

- ▶ Use only an approved vent starter coupling and approved vent pipe from the same manufacturer for Buderus SB boilers.
- ▶ Do not mix components from different systems.

NOTICE: Risk of system damage!

- ▶ Connect an oil-fired unit to a vent having sufficient draft at all times to ensure safe and proper operation of the unit.

The SB Boiler is a category II or IV appliance and the exhaust vent materials must be UL listed for use with a category IV appliance: operating temperatures of up to 240 °F, positive pressure, condensing flue gas service. Currently, UL Listed vents of AL29-4C or 316L stainless steel must be used with the SB Boiler. Proper clearances to combustibles must be maintained per UL and vent manufacturer instructions.



The specifying engineer should dictate flue venting as appropriate to the installation.

The vent system should be designed to facilitate smooth travel for both the intake and exhaust. Avoid the use of bullhead tees and back-to-back 90 degree elbows. The exhaust system must never be installed in a downward fashion. Be sure to follow all instructions provided by the vent manufacturer.

Keep the supply of combustion air free of corrosive substances (e.g. halogenated hydrocarbons that contain chlorine or fluorine compounds). This will help prevent corrosion. Never use or store

chlorinated cleaning agents or halogenated hydrocarbons (as contained in spray cans, solvents or cleaning agents, paints and adhesives, for example) in the boiler room.

UL, NFPA 54 & 211, ANSI Z223.1 (USA) and CGA-B.149.1 and 2 (Canada) guidelines are often the basis for state and local codes. Follow the guidelines of these recognized agencies unless codes applicable to the installation site are most stringent. The venting and combustion air systems must meet all applicable code requirements. Where code differs from the instructions provided with the equipment, code will take precedence.

Constant pressure at the flue gas outlet is not required. Size the flue system to limit pressure variations. The maximum allowable breech pressure for design of the flue system is positive 0.2" W.C. for proper combustion and light off.

A draft control system may be required to ensure proper draft when two or more boilers are connected to a common stack. Consult the flue material manufacturer for design calculations and recommendations.

Polypropylene Venting (Model SB625WS Series Boilers only)

The Model SB625WS Series Boilers may utilize an exhaust vent installed vertically through the roof or in a chimney chase. The configuration may be up to a maximum of 100 equivalent feet of venting. One 87 or 45 degree elbow is equivalent to 5 or 2.5 feet of venting, respectively. The chimney cap is equivalent to 3 feet of venting.

The following components may be employed:

	SB625WS-160 SB625WS-220	SB625WS-290 SB625WS-370	SB625WS-480 SB625WS-640
Centrotherm Innoflue SW - Polypropylene	200 mm (8 inch)	250 mm (10 inch)	315 mm (12 inch)
Straight Length ¹	ISVL08X	ISVL10X	ISVL12X
elbow 87 degree	ISEL0887	ISEL1087	ISEL1287
elbow 45 degree	ISEL0845	ISEL1045	ISEL1245
Vent Terminations			
Chimney Cap	ISCS08	ISCS10	ISCS12
Straight Gray Roof terminal	ISEP086	ISEP106	ISEP126

Table 11 Polypropylene Venting

1. x = 1, 2, 3 or 6, which indicates the length in feet

For installation in Canada: In accordance with CSA B149.1 Natural Gas and Propane Installation Code, vents constructed using plastic piping shall be certified to ULC S636.

5.7 Code Required Vent Terminations

Horizontal Terminations:

- Vent terminations should be at least 4 feet below, 1 foot above or 4 feet horizontally from any window, door or gravity air inlet of a building.
- The termination shall be at least 6 feet away from any other building opening, gas utility meter, service regulator or the like.
- The termination shall be at least 6 feet away from the combustion air intake of any other appliance.
- The bottom of the vent terminal should be at least 12 inches above both finished grade and any snow accumulation point.
- Vent should not terminate over public walkways or over an area where condensate or vapor could create a nuisance or be detrimental to the operation of regulators, meters and other equipment.
- Discharges should not be in wind-blocked areas, corners, or directly behind vegetation.

Vertical Terminations:

- Roof penetrations should follow all appliance codes and the vent manufacturer's instructions. The vent should never be installed at less than the required clearances to combustible materials per UL, NFPA and local codes. "Double-wall or thimble" assemblies are required when penetrating combustible walls and roofs.
- Vertical discharges should extend at least 2 feet above the roof through properly flashed penetrations and at least 2 feet above anything within a 10 foot horizontal diameter. Discharges that extend more than 2 feet above the roof must be laterally supported.
- If the vent systems is to be connected to an existing stack, the stack must be UL Listed for Category II or IV appliances (capable of 240 °F, positive pressure and condensing flue gas operation).
- Masonry stacks must be lined and the vent penetration must terminate flush with and be sealed to this liner. Vents may enter the stack through the bottom or side.
- SB Boiler vent systems must not be interconnected to any other venting system; The SB Boiler is designed to maintain its own vent system.
- The exhaust vent must be pitched up toward the termination a minimum of ¼ " in. per foot of length. Condensate must flow back to the boiler flue collector freely, without accumulating in the vent.

5.8 Combustion Air from outside the building

Two permanent openings method - If outside combustion air is required, the room shall have two permanent louvered openings to the outdoors. Each opening must have a minimum free area of 1 square inch for each 4,000 Btu/hr of total input rating of all fuel burning equipment in the space.

When the air is supplied to the room via ducts, two ducts must be used. Vertical ducts and openings must have a minimum free area of 1 square inch for each 4,000 Btu/h of the total input rating of all fuel burning equipment in the space. Horizontal ducts and openings must have a minimum free area of 1 square inch for each 2,000 Btu/h of the total input rating of all fuel burning equipment in the space.

One permanent opening method - If outside combustion air is required, the room shall have one permanent louvered openings to the outdoors. The opening must communicate directly with the outdoors or through a duct in either a vertical or horizontal arrangement. The opening must have a minimum free area of 1 square inch for each 3,000 Btu/hr of total input rating of all fuel burning equipment in the space.

The free area of the openings must be taken into account restrictions from the louvers and screens. The louver manufacturer should be consulted for the percentage of free area available. When free area is not known, metal louvers typically have 60-70% of free area, wooden louvers have between 20-25% of free area. Louvers should be in a fixed position or interlocked with equipment so that they open automatically during equipment operation. The combustion air damper opening shall be located as follows: top louver shall be within 12" of the ceiling and the bottom louver within 12" of the floor as prescribed in NFPA 54.

Direct intake method - If outside combustion air is required, air may be drawn from the outdoors via a duct connected directly to the burner intake. The duct shall be constructed of galvanized steel or a material having equivalent strength and rigidity. Refer to the burner manufacturer's recommendations and installation instructions for additional guidelines and application requirements.

5.9 Combustion Air from an adjacent room

Where combustion air is to be used from within the building, air must be provided into the equipment room through two permanent openings into the inferior building. Each opening must have a minimum free area of 1 square inch for each 1,000 Btuh of the total input rating of all fuel burning equipment in the space. The louvers shall be located as follows: top louver shall start within 12" of the ceiling and the bottom louver within 12" of the floor as prescribed in NFPA 54.

5.10 Condensate Removal

The exhaust vent pipe must be pitched at least ¼ " per foot of length back to the boiler. This will allow condensate to drain back to the unit to be disposed. Low spots in the venting where condensate may collect should be avoided. A plastic hose or PVC drain pipe may be used to condensate discharge to the neutralization system. Care should be taken to avoid kinks and from raising the drain line above the trap assembly.

5.11 Condensate

5.11.1 Draining the condensate

Condensing boilers produce a flow of condensate that varies according to operating conditions. The maximum hourly production of condensate is shown in the technical specifications table for each individual model. The condensate drain system must be suitably dimensioned to cope with the flow produced. Also, pipe and hose diameter must not be less than 1" at any point. This diameter corresponds to that of the boiler's condensate drain fitting [1].

The connection to the waste water drain pit must be made in compliance with national and local legislation and standards.

To prevent combustion fumes from leaking into the air of the boiler room, the condensate drain pipe must incorporate a siphon creating a minimum head equivalent to the fireside pressure drop (→ Tab. 5, page 9) plus 1 inch W.C. The connecting pipes between the boiler, siphon and waste water drain pit must be laid at a minimum down slope of 3° and must be installed in such a way as to prevent any build-up of condensate.

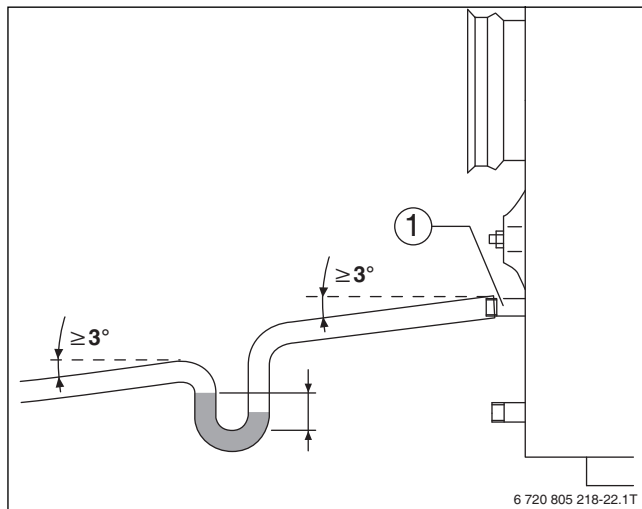

Fig. 23 Draining the condensate

[1] Condensate drain fitting

EX: (SB625WS/290)

- Boiler pressure = 1.284 inches W.C.
- Siphon head = 1.284 inches + 1 inch = 2.28 inches (approx.)

5.11.2 Neutralizing the condensate

Neutralization unit types NB-5LP, NB-6

The NB neutralization unit is designed for systems with boiler condensate drain pits located at a lower level than the boiler condensate drain fitting. These neutralization units do not require any electrical connections.

Type	Dimensions inch [mm]	Fitting Ø
NB-5LP	9x36 1/4x7 5/16 (228x921x192)	1"
NB-6	12x12x12 3/16 (305x305x306)	1"1/4

Table 12 Neutralization unit types NB-5LP, NB-6

The inlet fitting of the NB neutralization unit (the lower fitting) must be connected to the boiler condensate drain fitting.

The outlet fitting of the neutralization unit (the top fitting) must be connected to the boiler room's waste water drain pit using a section of flexible hose or PVC pipe (not supplied).

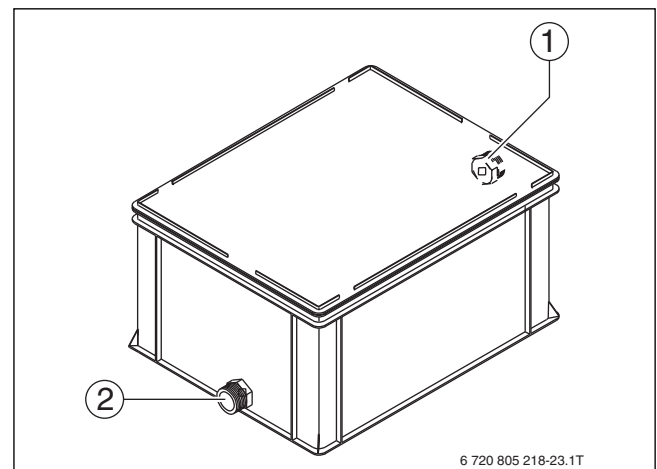

Fig. 24 Neutralization unit type NB-5LP

- [1] Outlet fitting
- [2] Inlet fitting

NOTICE:
The boiler room's condensate drain pit must be located at a lower level than the fitting on the neutralization unit.

NOTICE:
All connecting hoses must be kept as straight and as short as possible. Any curves or sharp bends can lead to the hoses becoming clogged and can therefore prevent proper condensate discharge.

If it ever proves necessary to neutralize the condensate that forms in the flue gas stack, connect the condensate drain fittings of the boiler and flue gas stack together using a 'T' union and connect the leg of the 'T' to the inlet of the neutralization unit.

6 Commissioning

NOTICE: Risk of boiler damage through contaminated combustion air.

- ▶ Never operate the boiler in very dusty conditions, e.g. if building work is taking place in the installation room.
- ▶ Ensure adequate ventilation.
- ▶ Never use or store chlorinated cleaning agents or halogenated hydrocarbons (as contained in spray cans, solvents or cleaning agents, paints and adhesives, for example) in the boiler room.
- ▶ A burner contaminated during building work must be cleaned before commissioning.
- ▶ All cover plates, enclosures, clean out ports, and guards must be in place at all times, except during maintenance and servicing.
- ▶ Never burn garbage or paper in the unit, and never leave combustible materials around it.

6.1 Control unit settings



The boiler may be operated with a Buderus Logamatic control unit from the 4000 series.

The purpose of optimum control unit settings is to achieve long burner run times and avoid rapid temperature changes in the boiler. Gentle temperature changes result in a longer service life of the heating system. The control strategy of the control unit must therefore be prevented from becoming ineffective, i.e. through the boiler water regulator switching the burner on and off.

Control unit settings

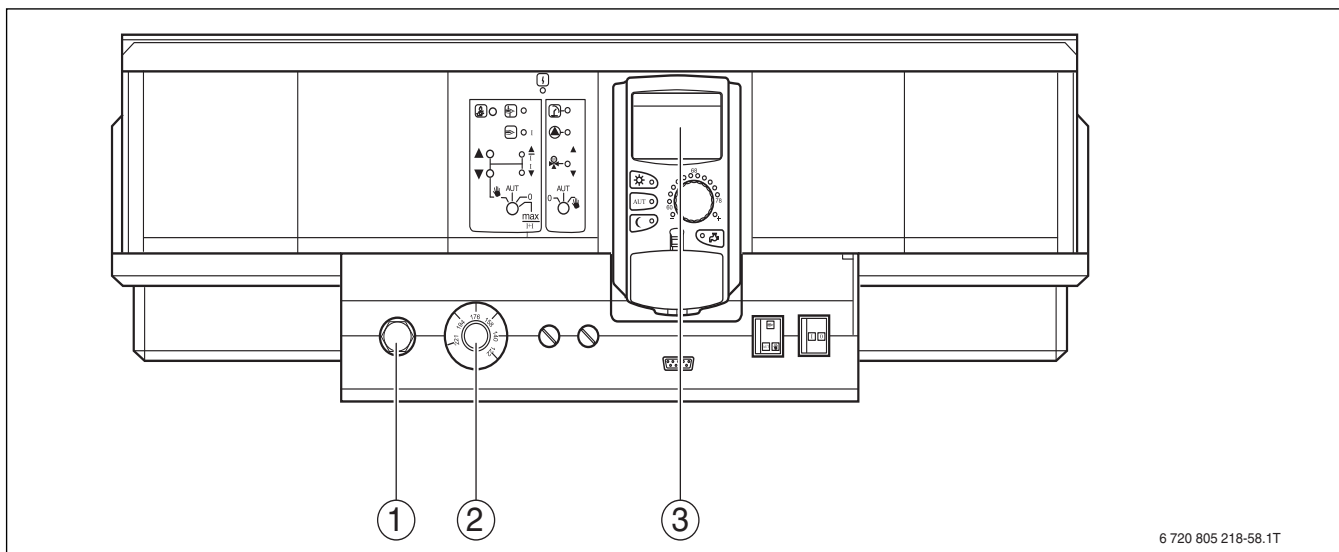

Fig. 25 Control unit settings

- [1] High limit safety cut-out
- [2] Temperature regulator
- [3] MEC

- ▶ Select temperatures (→ table 13, page 26) at high limit safety cut-out [1] on the control unit and at temperature controller [2].

- ▶ Maintain the minimum differential between the selected shutdown temperature of the high limit safety cut-out, the temperature regulator, the maximum boiler water temperature and the maximum temperature demand (→ table 13).



The maximum boiler water temperature can be selected on the control unit (MEC) in the "Boiler parameters" menu, under menu item "Max. shutdown temperature".

- ▶ Select set temperatures for the heating circuits that are as low as possible.
- ▶ Start heating circuits (e.g. when starting up in the mornings) at 5-minute intervals.



If the Buderus Logamatic 4000 control unit is used, burner modulation in standard mode is not enabled for 3 minutes. Never modulate upwards more quickly than this.

Recommended parameters (max. temperature)	Logamatic 4321	
High limit safety cut-out (STB)	230 °F/110 °C	↓↑min. 5 K↑
Temperature regulator (TR) and manual reset high limit.	210 °F/99 °C	↓↑min. 6 K↑
Max. boiler water temperature	198 °F/92 °C	↓↑min. 7 K↑
Max. temperature demand of Heating Circuit or DHW¹	185 °F/85 °C	

Table 13 Adjustable parameters for Logamatic 4321

1. Both temperature demands must always be at least 7 K below the maximum boiler water temperature.

- ▶ Select the maximum boiler water temperature at the MEC [3].



The maximum temperature demand is not a value that is directly selected. The maximum temperature demand is composed of the set temperature and the rise.

Example DHW demand (where the 4000 series controls the DHW system):

Sum of the set DHW temperature (140 °F) and parameter "Boiler rise" (40 °F) in the "DHW" menu:

$$140\text{ °F} + 40\text{ °F} = \text{Maximum temperature demand } 180\text{ °F}$$

Example heating circuits (where the 4000 series controls the heating circuits):

Add of the set temperature of the heating circuit with mixing valve with the highest temperature required (15 °F) and parameter "Boiler rise" (160 °F) in the "Heating circuit data" menu:

$$160\text{ °F} + 15\text{ °F} = \text{Maximum temperature demand } 175\text{ °F}$$

Notes on setting third party control units

NOTICE: System damage due to incorrect sensor position!
Safety cut-out and thermostat sensors of third party control units must be fitted in the instrument bulb/probe socket of the heating supply (→Fig. 1[6], page 5) of the boiler.
▶ Do not change the length of the immersion sleeve.

- The third party control unit (building management system or PLC controllers) must ensure a maximum internal boiler water temperature that is sufficiently different from the high limit safety cut-out. It must also be ensured that the digital burner controller rather than the boiler water temperature regulator switch the burner on and off.
- The control unit must ensure that the burner is switched to low load before being shut down.
- Select control equipment that allows a gentle start-up with a time delay when the system is cold.
- After the burner demand, an automatic timer (for example) should limit the burner to low load for a period of approx. 180 seconds. This restricted heat demand will prevent uncontrolled starting and stopping of the burner.
- It must be possible to show the number of burner starts on the control unit used.

	Unit	Value
Temperature control unit	s	40
Monitor/limiter	s	40
Minimum difference between burner on and off temperatures	K	7

Table 14 Conditions of use

6.2 Hydraulic connection to the heating system

- ▶ If the system temperatures are different, use both return connectors 3 (high temperature) and 2 (low temperature) (→chapter 2.9.3. Fig. 5 and 6, page 11, table 6, page 12)
- ▶ Connect heating circuits with high return temperatures to connector 3, and heating circuits with low return temperatures to connector 2.



For an optimum energy yield, we recommend supplying a flow rate of > 10% of the total nominal flow rate via the low temperature flange, with a return temperature below the dew point.



If there are no varying return temperatures, only the low temperature flange needs to be connected.

- ▶ Restrict the water flow rate in the boiler to a temperature difference of at least 7 K between supply and return.



Restriction of the temperature difference is not necessary if the system is equipped with a dirt trap device.

- ▶ Size the pumps correctly.



High flow rates and oversized pumps can result in the accumulation of sludge or deposits on the heat exchanger surfaces.

- ▶ Before connecting the boiler, flush sludge and dirt out of the heating system.
- ▶ Ensure that no oxygen enters the heating water during operation.
- ▶ Only operate the boiler in sealed unvented systems.

6.3 Hydraulic flow through boiler

The SB Series does not require a minimum flow rate in order to maintain warranty. The boiler has been designed to operate with a temperature difference between the supply and return of up to 100 °F. Flow should be initiated with the start of the burner to minimize temperature fluctuations and control deviations. The field installed manual reset high limit (as required by CSD-1) must be fitted to the instrument bulb/probe socket of the heating supply, set to 210 °F and electrically connected into the Logamatic 4321 safety circuit terminals (17,18) or the burner enable/disable circuit directly (see Fig 26).

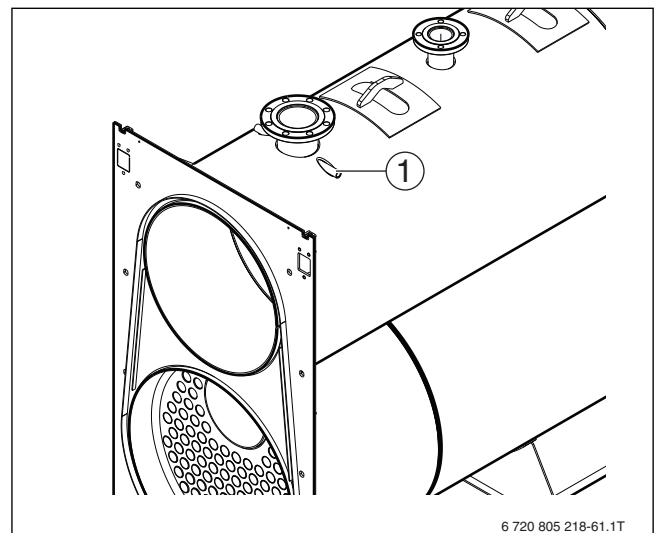

Fig. 26

[1] Instrument bulb/probe socket of the heating supply

6.4 Making the electrical connection



DANGER: Danger to life through electric shock!

- ▶ Before opening the boiler, isolate the heating system across all life phases and secure against unintentional reconnection.
- ▶ Carefully route the cables/leads and capillary tubes.
- ▶ Ensure that capillaries are never kinked.
- ▶ Only carry out electrical work if you are a competent person. If you are not suitably qualified, arrange for a qualified electrician to make the electrical connections.
- ▶ Observe local installation regulations.
- ▶ Create all electrical connections in accordance with National Electrical Code, Canadian Electrical Code or the applicable and local regulations.

NOTICE:

The phase-neutral polarity has been respected.
A ground (earth) connection is obligatory.



The locations of terminal strips on Logamatic control units are not identical. The terminal strip is easy to identify after the Logamatic control unit has been opened.

The labelling of the terminal strip in the various control units is identical.



Wiring diagrams related to the burner installation may be found in the burner installation manual.

- ▶ Knock out or cut out the appropriate parts from the back panel (→ Fig. 28, [1]) as required.
- ▶ Route all cables and leads for connecting the temperature sensors and safety equipment via the cable conduit to the back of the control unit.
- ▶ Route all on-site cables to the control unit.
- ▶ Route sensor leads separately from other electrical cables.

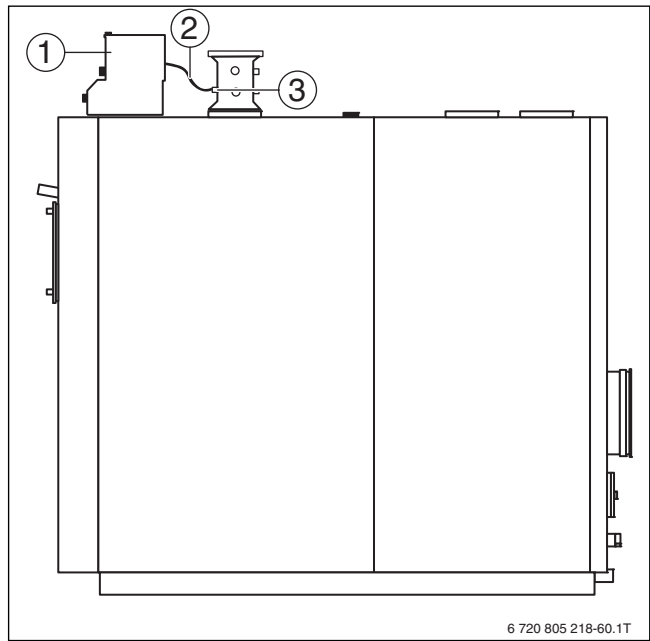

6 720 805 218-60.1T

Fig. 27 Cable conduit at the control unit

- [1] Control unit
- [2] Cable conduit
- [3] Sensor well

- ▶ Make the plug-in connection in the control unit in accordance with the labelling on the terminal strip.
- ▶ Make on-site electrical connections to the appropriate plug-in connections according to the connection diagram (→ control unit documentation).

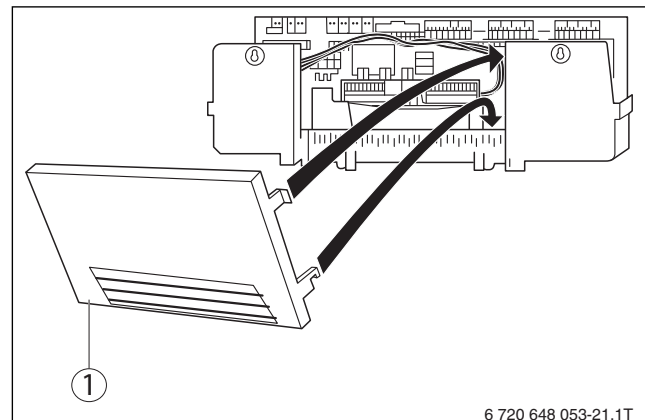

6 720 648 053-21.1T

Fig. 28 Preparing the cable entry

- [1] Back panel section (Logamatic 4000)

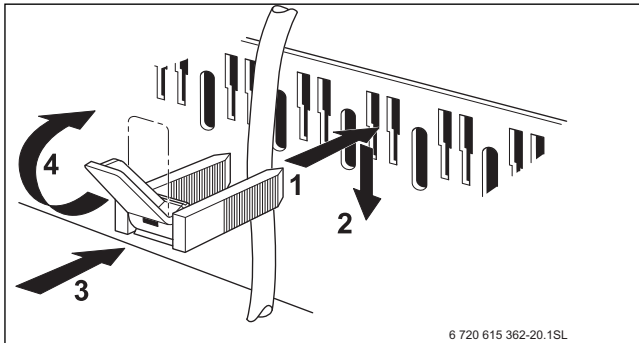

Fig. 29 Securing a cable with a cable clip

Secure all cables with cable clips (part of the control unit standard delivery) or sleeve in a conduit (if required by code). Perform the following steps to secure the cables:

- ▶ Insert the cable clip together with the cable from the top into the slot in the frame.
- ▶ Slide the cable clip downwards.
- ▶ Counterhold.
- ▶ Flip the lever up.
- ▶ Fit the back panel.
- ▶ Refit the cover to the control unit.
- ▶ Fix the control unit cover with the screws supplied.

6.5 Fitting temperature sensors

NOTICE: System damage through damaged capillaries or incorrectly fitted temperature sensor.

- ▶ Ensure that the capillaries are neither kinked nor squashed when uncoiling and routing them.
- ▶ Always push the temperature sensor right to the bottom of the sensor well.

NOTICE: System damage due to incorrect sensor position!

The safety cut-out (STB) and thermostat (TR) sensors of the Logamatic 4321 control unit **must** be fitted at the installation site (→ picture 27, [1], page 28) on the top of the boiler.

- ▶ In the case of third party control units, safety cut-out and thermostat sensors of third party control units must be fitted in the instrument bulb/probe socket of the heating supply (→ Fig. 1,[6], page 5) of the boiler.
- ▶ Do not change the length of the immersion sleeve.



Standard immersion sleeve used: 3/4"

The boiler test point is at the top of the boiler body (→ Fig. 27, [1], page 28).

- ▶ Measure the depth of the sensor well.
- ▶ Mark the depth on the temperature sensor set (lead).

- ▶ **Insert the temperature sensor set as far as it will go into the test point (to the bottom).**

Use the mark to check whether the temperature sensors are correctly fitted.

- ▶ Secure the temperature sensor set in the test point with a sensor retainer.

The plastic coil [2] for keeping the temperature sensors together is pushed back automatically when it is inserted.



Insert compensating spring [1] between the temperature sensors to ensure a good contact between sensor well [4] and sensor surfaces, and thereby a reliable temperature transfer.

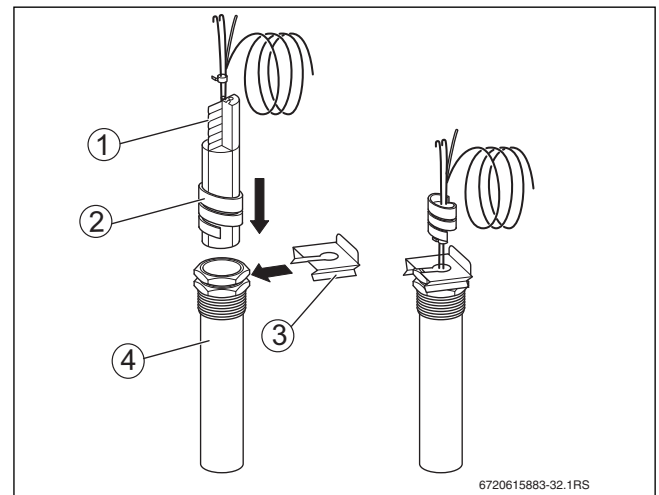

Fig. 30 Inserting the plastic coil into the sensor well

- [1] Compensating spring
- [2] Plastic spiral
- [3] Sensor retainer
- [4] Sensor well

- ▶ Never kink excess lengths of capillaries.
- ▶ Route the sensor lead through the cable conduit to the control unit.
- ▶ Connect the sensor lead to the control unit
- ▶ Complete the commissioning report (→ chapter 6.11, page 31).

6.6 Flushing the heating system



If the heating system contains several heating circuits, these must be flushed one after the other.

To prevent contamination in the boiler, flush the heating system prior to commissioning.

- ▶ Flush the system prior to connection to the boiler.

-or-

- ▶ Isolate the heating flow and return at the boiler.
- ▶ Connect the heating flow to a water connection.
- ▶ Connect hose to the heating return of the heating system.
- ▶ Route hose from the heating return to a drain.
- ▶ Open connected consumers (e.g. radiators).
- ▶ Flush the heating system with fresh water until clear water emerges from the heating return.
- ▶ Drain the heating system.

6.7 Filling the heating system



CAUTION: Health risk through contaminated drinking water.

- ▶ Observe all country-specific regulations and standards regarding the prevention of drinking water contamination.

NOTICE: System damage through temperature stresses.

- ▶ Only fill the heating system when cold (the flow temperature must not exceed 104 °F (40 °C)).
- ▶ During operation, only fill the heating system via the fill valve in the heating system pipework (return).



Open the automatic air vent valve only briefly for venting.

The fill and top-up water quality must comply with the water requirements in this manual.

The pH value of the heating water increases after the heating system has been filled. After 3 – 6 months (initial service) check whether the pH value of the heating water has settled down.

- ▶ Adjust the pre-charge pressure of the expansion vessel to the required pressure (only for sealed unvented systems).
- ▶ Open the shut-off valves on the heating water side.
- ▶ Fill the heating system slowly and observe the pressure gauge whilst doing so.
- ▶ Vent the heating system via the radiator air vent valves.

If the water pressure drops as a result of venting the system:

- ▶ Top up the system with water.
- ▶ Carry out a leak test in accordance with locally applicable regulations.
- ▶ After the tightness test, reinstate all components that were taken out of operation.
- ▶ Ensure that all pressure, control and safety equipment is functioning correctly.

Once the boiler has been tested for tightness and no leaks have been found:

- ▶ Set the correct operating pressure. The working pressure in the heating system should be over 14 PSI but below the maximum limit specified for the boiler.
- ▶ Close the automatic air vent valve.

6.8 Preparing the heating system for operation

Observe the following points during commissioning:

- ▶ The turbulators [2] are correctly positioned (horizontal) inside the heat exchanger tubes and the clips [1] are resting against the wall [3] of the heat exchanger.

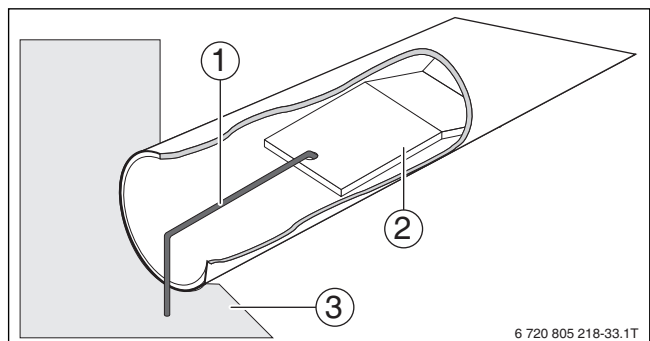

Fig. 31 Heat exchanger tube

- [1] Clip
- [2] Turbulator
- [3] Wall

- ▶ Before commissioning, vent the heating system via the ventilation facilities provided for this purpose.
- ▶ Check that the inspection aperture on the flue gas collector is closed.
- ▶ Check that the combustion chamber door is securely closed.
- ▶ Check that the safety equipment (e.g. safety valve, minimum and maximum pressure limiters, high limit safety cut-out) is functioning correctly.
- ▶ Check that the required operating pressure has been achieved.
- ▶ Check the flange connections and other connections for tightness.
- ▶ Check the control unit connections and temperature sensor positions.
- ▶ Fill the condensate siphon.

6.9 Commissioning the control unit and burner

By commissioning the control unit you automatically commission the burner as well. The burner can then be started by the control unit. For further information, see the installation instructions of the relevant control unit or burner.

- ▶ Use the control unit to commission the boiler.
- ▶ Set the control unit parameters (→ chapter 6.10, page 30).
- ▶ Complete the commissioning report in the technical documentation of the burner.

6.10 Setting control unit parameters

The controller settings listed in table 15 apply to the Logamatic 4321 control unit.

For further information on setting the control unit, see chapter 6.1, page 26.

Burner	Control unit setting		
	Burner type for fuel gas	Burner type to be selected	Fuel to be selected
Single fuel burner	Modulating	Modulating	Gas
	2-stage	2-stage	Gas

Table 15 Controller settings for Logamatic 4321 control unit

6.11 Commissioning report

The boiler can be operated with a gas or dual fuel burner.

- ▶ Carefully complete the commissioning report for the relevant approved burner.
- ▶ Sign all completed commissioning work and enter the date.

Commissioning steps	Comments (signature)
1. Flush the heating system.	
2. Fill the heating system with water.	
3. Vent the heating system.	
4. Carry out tightness test.	
5. Switch on the control unit. ▶ Boiler-specific parameters set and recorded.	
6. Ensure the function of all safety equipment.	
7. Check the fuel line for tightness.	
8. Start the burner.	
9. Complete the burner test report regarding the individual output stages.	
10. Conduct a tightness test on the hot gas side. After a short time in operation, tighten the screws in the combustion chamber door to prevent leakage around the door as a result of the packing cord settling.	
11. Check the flange connections and fitting after the boiler has been heated up and retighten.	
12. Check flue path for tightness.	
13. Check the flue gas temperature.	
14. Carry out a function test on all safety equipment and record this.	
15. Instruct the system user and hand over technical documentation.	
16. Enter the fuel used in the table (→ "General" operating instructions).	
17. Confirm commissioning by a competent person.	
Company stamp/signature/date	

Table 16 Commissioning report

7 Shutting down

NOTICE: Risk of system damage through frost.
When there is a frost, the heating system can freeze up if it is not operational, e.g. because of a fault shutdown.

- ▶ When there is a risk of frost, protect your heating system against freezing up.
- ▶ If your heating system has been shut down for several days due to a fault shutdown and there is a risk of frost, drain the heating water at the drain & fill valve. Also leave the air vent valve at the highest point in the system open.

NOTICE: Risk of system damage through frost.
The heating system can freeze up as a result of a power failure or if the power has been switched off.

- ▶ Check the "Control unit settings" to ensure the system remains operational (especially when there is a risk of frost).

NOTICE:

- ▶ Always keep the oil supply valve shut off if the burner is shut down for an extended period of time.

7.1 Shutting down the heating system

Shut down your heating system via the control unit. Switching off the control unit also switches off the burner automatically.

- ▶ Set the On/Off switch of the control unit to "0" (Off).
- ▶ Isolate the fuel supply to the burner.

7.2 Shutting down the heating system in an emergency



Only in emergencies, switch OFF the heating system via the boiler room breaker or the heating system emergency stop switch.

- ▶ In dangerous situations, immediately close the main fuel shut-off valve and the power supply of the heating system via the boiler room main breaker or the heating system emergency stop switch.
- ▶ Isolate the fuel supply to the burner.
- ▶ Never put your life at risk. Your own safety is paramount.

System A

- ▶ Make sure that the safety bolts [1] on the side of the boiler are tight.

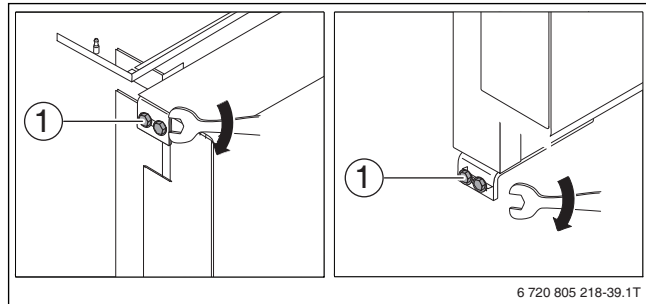

6 720 805 218-39.1T

8 Inspection and maintenance

8.1 Why is regular maintenance important?

Heating systems require regular maintenance and service for the following reasons:

- to maintain a high level of efficiency and to operate the system economically (low fuel consumption),
- to achieve a high level of operational reliability
- to maintain the cleanest possible combustion

The operator is required to have the entire heating system at least once a year maintained, serviced and cleaned.

We recommend that an annual inspection and as-required service contract is signed.

The servicing work carried out should be recorded.

Burner servicing should be carried out in accordance with the instructions of the burner manufacturer.



Only use genuine Bosch spare parts. You can order spare parts from the spare parts catalog.

8.2 Maintenance



DANGER: Risk to life from electric shock!

- ▶ Before opening a unit: disconnect electrical power and lock to prevent accidental reactivation.



DANGER: Risk to life from explosion of flammable gases!

- ▶ Work on gas components must only be carried out by qualified and authorized gas fitters.

NOTICE:

- ▶ All cover plates, enclosures, and guards must be in place at all times, except during maintenance and servicing.

Analyze the combustion flue gas before commencing any maintenance. The results of flue gas analysis can give a clear idea of what servicing or repairs are needed.

8.2.1 Opening the door

- ▶ Turn the system's main power switch OFF.
- ▶ Close all the fuel cocks.

Fig. 32 Tighten safety bolts

[1] Safety bolts

System A and B



The first time you open the door, remove the spare hinge assembly 'B' (bushing, bolt, and washer) opposite the pivot side of the door.

- ▶ Remove the main fixing bolts (→ Fig. 33, [2]) holding the door in place.

8.2.2 Adjusting the door

Make sure that the door presses uniformly all around the double seal to prevent dangerous fumes escaping into the air. Proceed as follows to adjust the door seals.

System A

- ▶ Fit the door and tighten the main fixing bolts [2] until the seals start to compress.
- ▶ Loosen the safety bolts [1] then fully screw in the main door fixing bolts [2].
- ▶ Tighten the safety bolts [1].

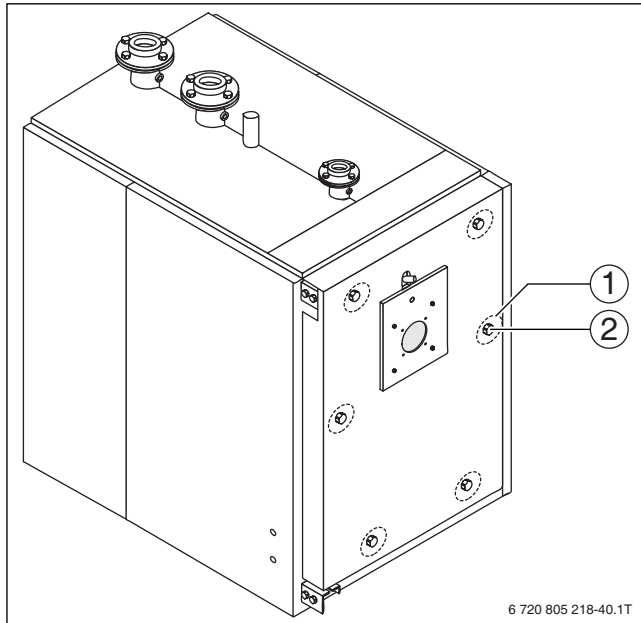

Fig. 33 Adjust the door

- [1] Safety bolts
- [2] Fixing bolts

System B (larger size)

- ▶ Put the door in its correct position.
- ▶ Tighten the main locking screws [1] until the packing starts to be compressed.

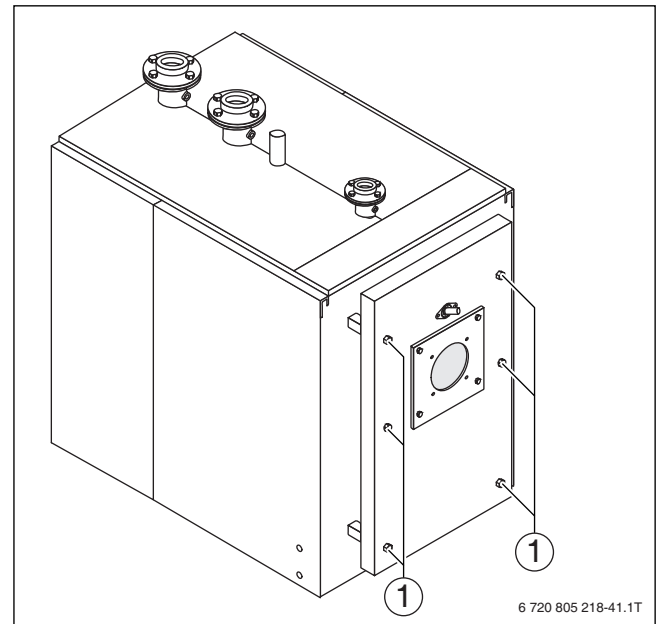

Fig. 34 Position the door



Make sure that the door is properly adjusted after every maintenance operation.

8.3 Cleaning the boiler



DANGER: Risk to life from electric shock!

- ▶ Before opening a unit: disconnect electrical power and lock to prevent accidental reactivation.



WARNING: System damage!

- ▶ Do not use abrasive cleaning pads or powder detergents.

NOTICE:

The combustion chamber and flues must be cleaned periodically - at least once a year - by a qualified technician.

Use a cloth damped in soapy water to clean the boiler's external paneling.

To remove stubborn marks, use a cloth damped in a 50% mix of water and denatured alcohol or a suitable cleaning product.

Carefully dry the boiler after cleaning.

Clean the boiler and remove any carbon deposits from the surfaces of the heat exchanger **at least once a year**. This not only extends the boiler's working life, but also keeps it efficient in terms of heat output and consumption.

- ▶ Open the door [1] and pull out the turbulators [2].
- ▶ Use a flue brush [3] or other suitable tool to clean inside the combustion chamber and the flue gas pipes.

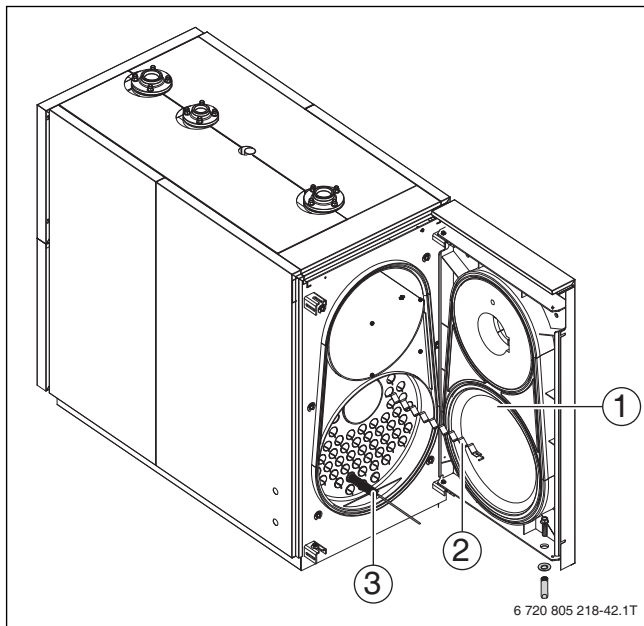

Fig. 35 Clean the boiler

- [1] Door
- [2] Turbulator
- [3] Flue brush

- ▶ Open the inspection port [3] and clean out any deposits from inside the flue gas box.

If more thorough cleaning is required:

- ▶ Remove the outer panels.
- ▶ Unscrew the eight fixing bolts and pull firmly on the flue gas box [1] to remove it from the boiler.
- ▶ Check at regular intervals that the condensate drain [2] is not blocked.

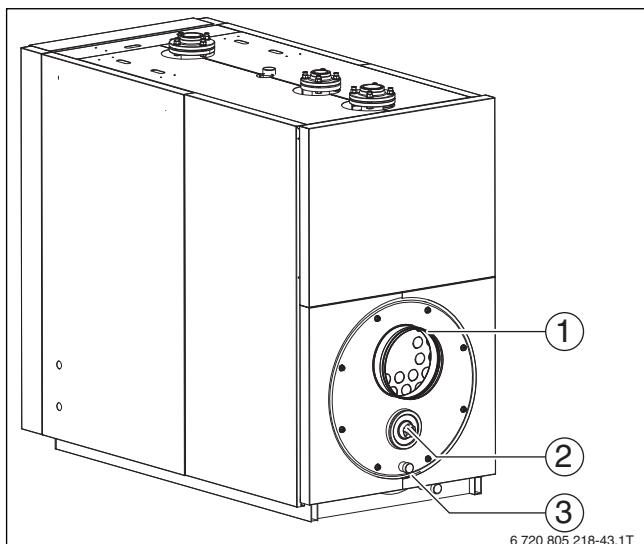

Fig. 36

- [1] Flue gas box
- [2] Inspection port
- [3] Condensate drain

- ▶ If necessary, replace the gasket [1].
- ▶ Clean all removed components, then follow the above steps in the reverse order to refit them.

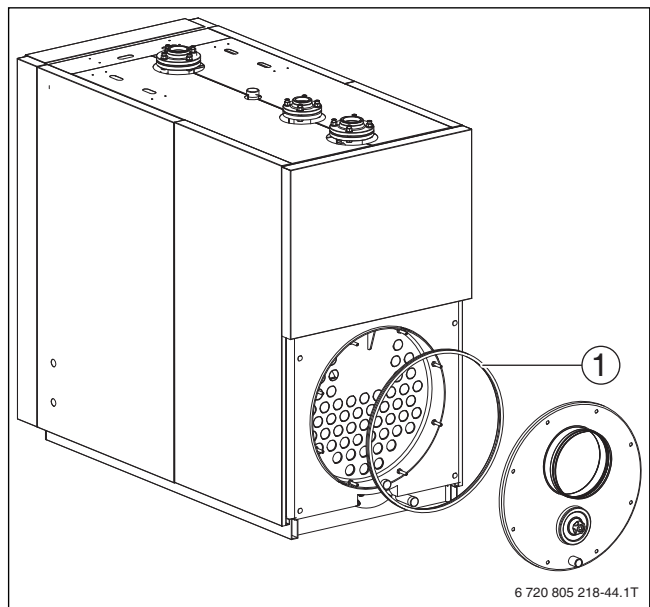

Fig. 37 Replace gasket

- [1] Gasket

8.4 Checking and correcting the water pressure

The heating system must contain sufficient water to safeguard its correct function.

- ▶ If the water pressure in the heating system is too low, top up with water.
- ▶ Check the water pressure monthly.

8.4.1 When should you check the water pressure in the heating system?



The fill and top-up water quality must comply with the water requirements in this manual.



Air pockets may form in the heating system through the fill or top-up water releasing gases.

- ▶ Vent the heating system (e.g. bleeding the radiators).
- ▶ If required, top up with water.

Recently added fill or top-up water loses much of its volume in the first few days because it releases gases. With new systems you should therefore initially check the heating water pressure on a daily basis, and then at gradually longer intervals.

- Once the heating system is hardly losing any volume, check the heating water pressure monthly.

A distinction is generally made between open vented and sealed unvented systems. In practice, open vented systems are hardly installed nowadays. We will therefore be using a sealed unvented heating system to demonstrate how you can check the water pressure. All settings will have already been made by the installation engineer when the system was first commissioned.

8.4.2 Sealed unvented systems

NOTICE: System damage through frequent topping up. Subject to the water quality, your heating system can be damaged through corrosion or scaling.

- ▶ Ensure that the heating system is vented correctly.
- ▶ Check the heating system for leaks and the expansion vessel for functionality.
- ▶ Observe the requirements regarding water quality.
- ▶ If water loss occurs frequently, locate the cause and rectify the problem without delay.

NOTICE: System damage through temperature stresses.

- ▶ Only fill the heating system when cold (the flow temperature must not exceed 104 °F (40 °C)).
- ▶ During operation, only fill the heating system via the fill valve in the heating system pipework (return).

For sealed unvented systems, the pressure gauge needle should be near the mid point of the gauge. The red needle of the pressure gauge must be set to the pressure required for the heating system.

- ▶ Check the heating system water pressure.
- ▶ Top up with water via the filling valve in the heating system pipework.
- ▶ Vent the heating system.
- ▶ Check the water pressure once more.

8.5 Inspection and maintenance reports

The inspection and maintenance reports provide an overview of the required inspection and service steps that should be carried out annually.

Complete these reports after inspections and service. The report can also be used as copying template.

- ▶ Sign and date the completed inspection work.



Warranty:
Annual inspection and service are part of the warranty terms.

	Inspection work	Page (individual steps)	Notes
1.	Check the general condition of the heating system (visual inspection).		
2.	Check the heating system function.		
3.	Check the components in contact with fuel and water throughout the system for the following: <ul style="list-style-type: none"> • Tightness • Visible signs of corrosion • Signs of ageing 		
4.	Check the combustion chamber and heating surface for contamination and clean them. For this, shut down the heating system.	Chapter 8.3, page 33	
5.	Check gaskets/packing cords on combustion chamber door and replace if required.		
6.	Check and clean the burner. <ul style="list-style-type: none"> ▶ Visual inspection and remove any contamination. ▶ Check all safety equipment (safety shutdown). ▶ Function check ▶ Flue gas analysis with test report for each output stage. 	See technical burner documentation.	
7.	Check the flue for function and safety.	See flue manufacturer documentation.	
8.	Check the hydraulic seal of the condensate siphon and replace if required.		
9.	Check the water pressure and pre-charge pressure of the expansion vessel.	Chapter 8.4, page 34	
10.	Check the control unit settings are suitable and adjust if required.	See technical control unit documentation.	
12.	Test all safety equipment (safety shutdown) and record findings. For example: <ul style="list-style-type: none"> ▶ High limit safety cut-out ▶ Pressure limiter min. ▶ Pressure limiter max. (if installed) ▶ Other safety equipment.v 		
13.	Conduct a water analysis and record the results in the operator's log: <ul style="list-style-type: none"> ▶ pH value ▶ Residual hardness ▶ Oxygen binder ▶ Phosphate ▶ Electrical conductivity ▶ Appearance ▶ Check water records (e.g. amount of top-up water) in the operator's log. 		
14.	Check the neutralisation system.		
15.	Final check of the inspection work, take measurements and record values and test results.		

Table 17 Inspection report

Confirm professional inspection with signature, date and company stamp.

Table 18 Inspection confirmation

9 Spare parts

The following replacement parts are available from Bosch Thermotechnology Corp.

SB625WS-160/220/290 (→ Fig. 38)

Item no.	Description	Article number	-160	-220	-290
1	Burner door complete	7738003072	x	x	-
1	Burner door complete	7738003073	-	-	x
2	Burner plate gasket	7738003078	x	x	-
2	Burner plate gasket	7738003079	-	-	x
3	Burner plate	7738003083	x	-	-
3	Burner plate	7738003159	-	x	-
3	Burner plate	7738003084	-	-	x
4	Gasket sight glass	7738003089	x	x	x
5	Sight glass	7738003090	x	x	x
6	Sight glass hex-nut	7738003091	x	x	x
7	Turbulator (10x)	7738003092	x	x	-
7	Turbulator (10x)	7738003093	-	-	x
8	Burner door gasket	7738003100	x	x	x
11	Probe holder sump	7738003155	x	x	x
12	Probe holder sump	7738003156	x	x	x
13	Sump spring	7738003154	x	x	x
14	Gasket rear inspection door	7738003103	x	x	x
15	Flue collector gasket	7738003104	x	x	-
15	Flue collector gasket	7738003105	-	-	x
16	Flue collector	7738003111	x	x	-
16	Flue collector	7738003112	-	-	x
17	Flue gas outlet o-ring	7738003117	x	x	-
17	Flue gas outlet o-ring	7738003118	-	-	x
18	Insulation blanket	7738003123	x	x	-
18	Insulation blanket	7738003124	-	-	x
19	Insulation boiler rear	7738003133	x	x	-
19	Insulation boiler rear	7738003134	-	-	x
20	Holding spring	7738003132	x	x	x
21	Front panel	7738003139	x	x	-
21	Front panel	7738003140	-	-	x
22	Paneling complete	7738003145	x	x	-
22	Paneling complete	7738003146	-	-	x
24	Inspection port	7738003209	x	x	x
25	Flue brush	7738003081	x	x	-
25	Flue brush	7738003208	-	-	x
27	Sealing rope	7738003157	x	x	x

Table 19 Spare parts SB625WS-160/220/290

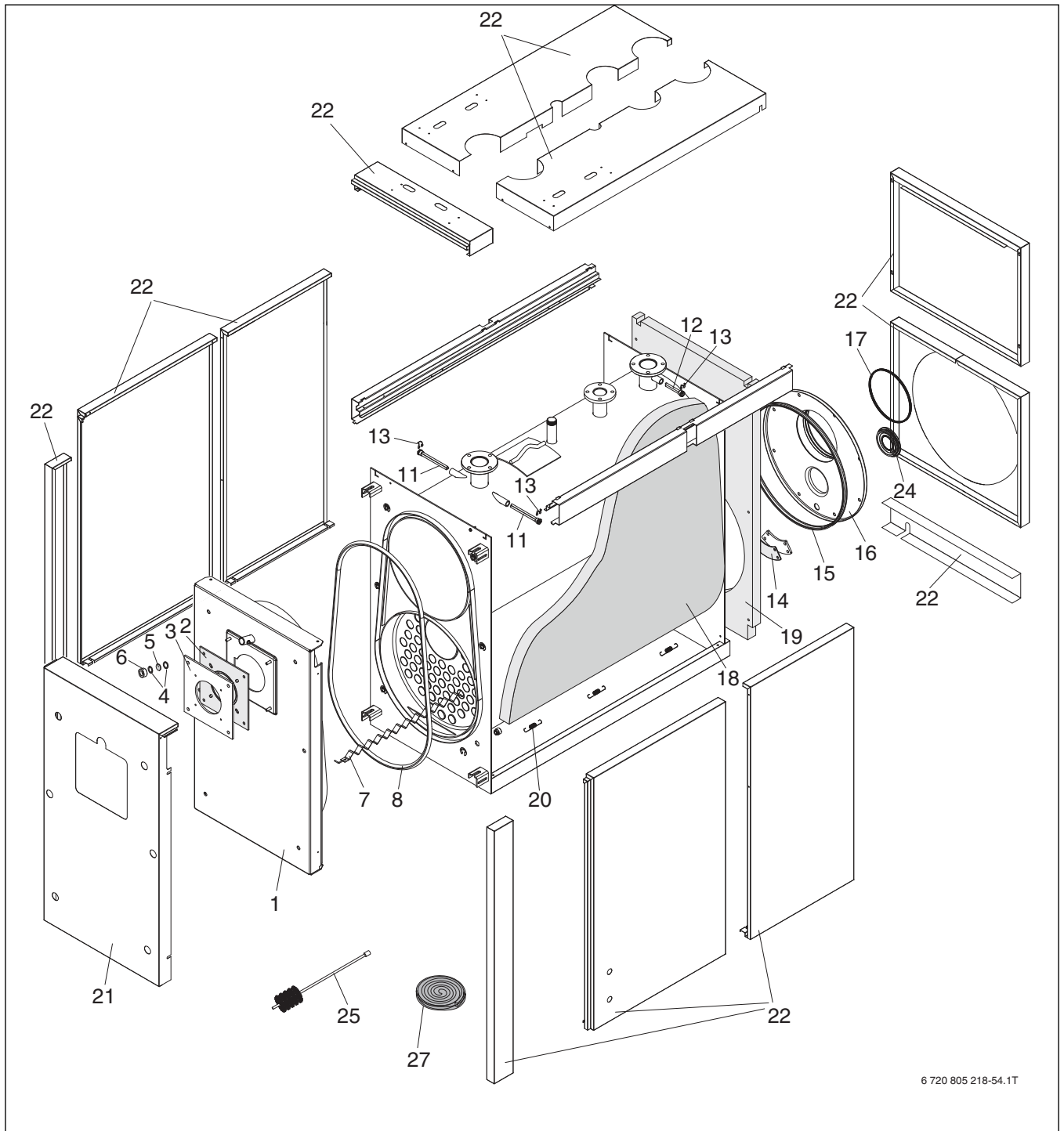

6 720 805 218-54.1T

Fig. 38 Spare parts SB625WS-160/220/290

SB625WS-370/480/640 (→ Fig. 39)

Item no.	Description	Article number	-370	-480	-640
1	Burner door complete	7738003073	x	-	-
1	Burner door complete	7738003074	-	x	x
2	Burner plate gasket	7738003079	x	-	-
2	Burner plate gasket	7738003080	-	x	x
3	Burner plate	7738003084	x	-	-
3	Burner plate	7738003121	-	x	-
3	Burner plate	7738003085	-	-	x
4	Gasket sight glass	7738003089	x	x	x
5	Sight glass	7738003090	x	x	x
6	Sight glass hex-nut	7738003091	x	x	x
7	Turbulator (10x)	7738003094	x	-	-
7	Turbulator (10x)	7738003095	-	x	-
7	Turbulator (10x)	7738003096	-	-	x
8	Burner door gasket	7738003100	x	x	x
11	Probe holder sump	7738003155	x	x	x
12	Probe holder sump	7738003156	x	x	x
13	Sump spring	7738003154	x	x	x
14	Gasket rear inspection door	7738003103	x	x	x
15	Flue collector gasket	7738003105	x	-	-
15	Flue collector gasket	7738003106	-	x	x
16	Flue collector	7738003112	x	-	-
16	Flue collector	7738003113	-	x	x
17	Flue gas outlet o-ring	7738003118	x	-	-
17	Flue gas outlet o-ring	7738003119	-	x	x
18	Insulation blanket	7738003125	x	-	-
18	Insulation blanket	7738003126	-	x	-
18	Insulation blanket	7738003127	-	-	x
19	Insulation boiler rear	7738003134	x	-	-
19	Insulation boiler rear	7738003135	-	x	x
20	Holding spring	7738003132	x	x	x
21	Front panel	7738003140	x	-	-
21	Front panel	7738003141	-	x	x
22	Paneling complete	7738003147	x	-	-
22	Paneling complete	7738003148	-	x	-
22	Paneling complete	7738003149	-	-	x
24	Inspection port	7738003209	x	x	x
25	Flue brush	7738003055	x	x	-
25	Flue brush	7738003056	-	-	x
27	Sealing rope	7738003157	x	-	-
27	Sealing rope	7738003166	-	x	x

Table 20 Spare parts SB625WS-370/480/640

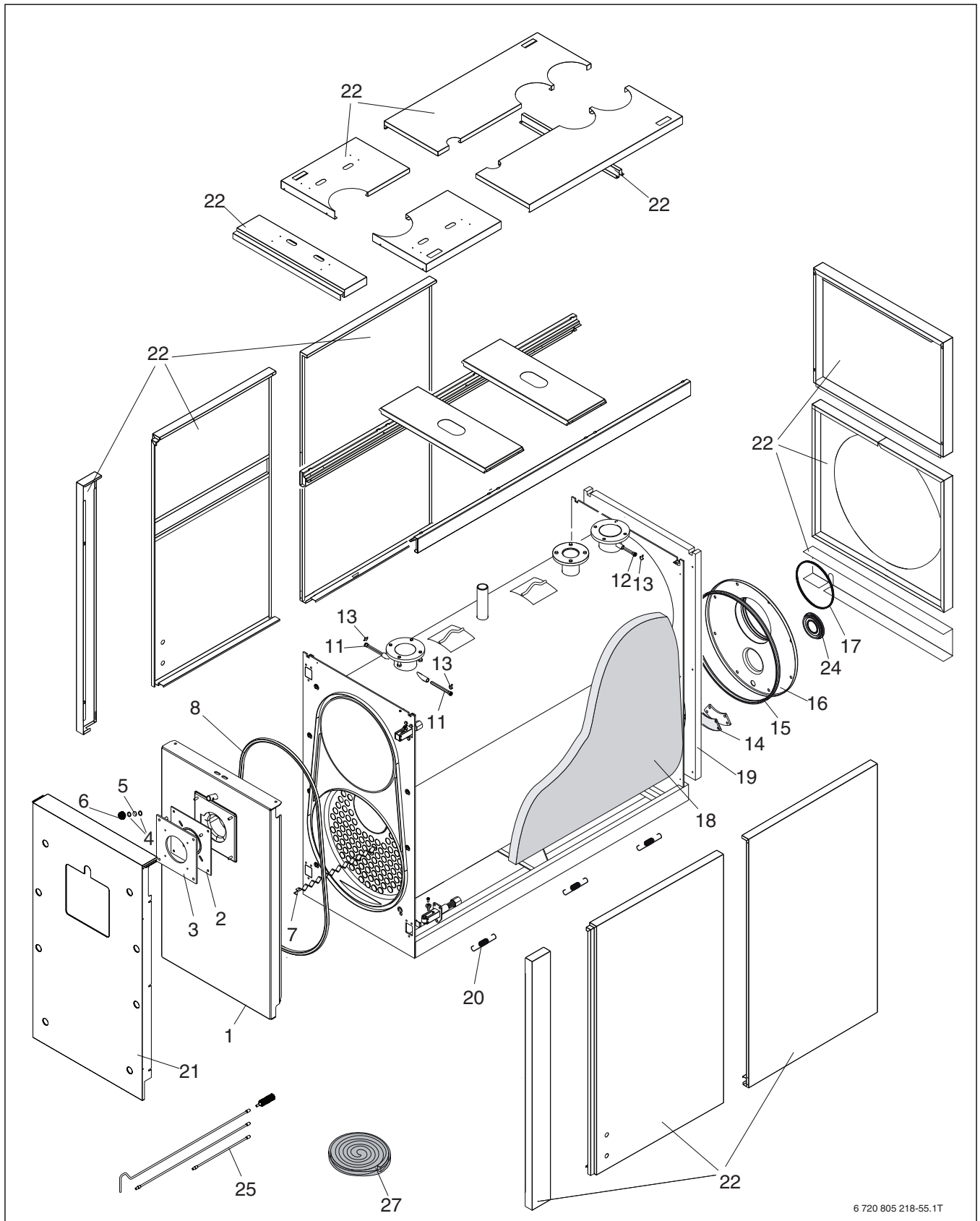

6 720 805 218-55.1T

Fig. 39 Spare parts SB625WS-370/480/640

SB745WS-800/1050/1300/1550 (→ Fig. 40)

Item no.	Description	Article number	-800	-1050	-1300	-1550
1	Burner door complete	7738003075	x	x	-	-
1	Burner door complete	7738003076	-	-	x	-
1	Burner door complete	7738003077	-	-	-	x
2	Burner plate gasket	7738003080	x	x	-	-
2	Burner plate gasket	7738003082	-	-	x	x
3	Burner plate	7738003085	x	-	-	-
3	Burner plate	7738003086	-	x	-	-
3	Burner plate	7738003087	-	-	x	-
3	Burner plate	7738003088	-	-	-	x
4	Gasket sight glass	7738003089	x	x	x	x
5	Sight glass	7738003090	x	x	x	x
6	Sight glass hex-nut	7738003091	x	x	x	x
7	Turbulator (10x)	7738003097	x	-	-	-
7	Turbulator (10x)	7738003098	-	x	-	-
7	Turbulator (20x)	7738003099	-	-	x	x
8	Burner door gasket	7738003101	x	x	x	-
8	Burner door gasket	7738003102	-	-	-	x
11	Probe holder sump	7738003155	x	x	-	-
11	Probe holder sump	7738003165	-	-	x	x
12	Probe holder sump	7738003156	x	x	x	x
13	Sump spring	7738003154	x	x	x	x
14	Gasket rear inspection door	7738003164	x	x	x	x
15	Flue collector gasket	7738003107	x	x	-	-
15	Flue collector gasket	7738003109	-	-	x	-
15	Flue collector gasket	7738003110	-	-	-	x
16	Flue collector	7738003114	x	x	-	-
16	Flue collector	7738003115	-	-	x	-
16	Flue collector	7738003116	-	-	-	x
17	Flue gas outlet o-ring	7738003120	x	x	-	-
17	Flue gas outlet o-ring	7738003108	-	-	x	-
17	Flue gas outlet o-ring	7738003122	-	-	-	x
18	Insulation blanket	7738003128	x	-	-	-
18	Insulation blanket	7738003129	-	x	-	-
18	Insulation blanket	7738003130	-	-	x	-
18	Insulation blanket	7738003131	-	-	-	x
19	Insulation boiler rear	7738003136	x	x	-	-
19	Insulation boiler rear	7738003137	-	-	x	-
19	Insulation boiler rear	7738003138	-	-	-	x
20	Holding spring	7738003132	x	x	x	x
21	Front panel	7738003142	x	x	-	-
21	Front panel	7738003143	-	-	x	-

Table 21 Spare parts SB745WS-800/1050/1300/1550

Item no.	Description	Article number	-800	-1050	-1300	-1550
21	Front panel	7738003144	-	-	-	X
22	Panelling complete	7738003150	X	-	-	-
22	Panelling complete	7738003151	-	X	-	-
22	Panelling complete	7738003152	-	-	X	-
22	Panelling complete	7738003153	-	-	-	X
25	Inspection port	7738003209	X	X	X	X
26	Flue brush	7738003057	X	-	-	-
26	Flue brush	7738003058	-	X	-	-
26	Flue brush	7738003059	-	-	X	X
28	Sealing rope	7738003166	X	X	X	X

Table 21 Spare parts SB745WS-800/1050/1300/1550

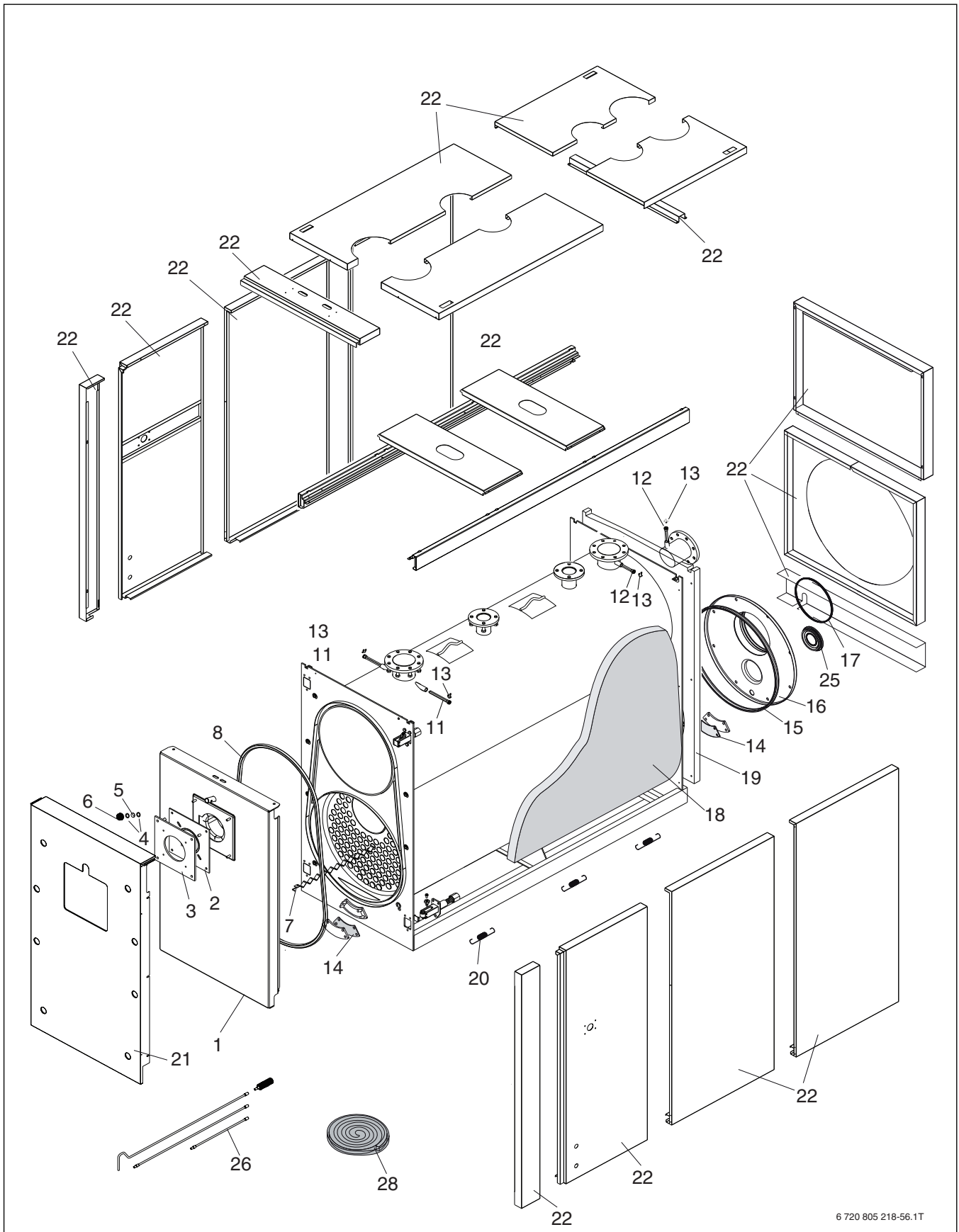

6 720 805 218-56.1T

Fig. 40 Spare parts SB745WS-800/1050/1300/1550

10 Troubleshooting

Problem	Cause	Troubleshooting
The boiler does not reach its set temperature.	Heat exchanger dirty.	▶ Clean the flue gas pipes.
	Heat exchanger and burner mismatched.	▶ Check specifications and settings.
	Insufficient gas flow burner.	▶ Check and adjust the burner.
	Control thermostat problem.	▶ Check the functioning of the aquastat. ▶ Check the temperature setting.
The boiler keeps shutting down, and the control panel warning light comes on.	Control thermostat problem.	▶ Check the functioning of the aquastat. ▶ Check the temperature setting. ▶ Check the electrical wiring. ▶ Check the sensor bulbs.
	No water supply. Air in the circuit.	▶ Check the circuit pressure. ▶ Check the vent valve.
The boiler has reached the set temperature but the radiators are still cold.	Air in the circuit.	▶ Bleed the circuit.
	Pump malfunctioning.	▶ Check/release the pump.
	Problem with minimum temperature aquastat (if present).	▶ Check the temperature setting.
There is a smell of fumes.	Fumes are escaping into the air.	▶ Check that the boiler body is clean. ▶ Check that the flue pipes are clean. ▶ Check that the boiler, flue pipes and flue gas exhaust stack are all properly sealed.
The safety valve keeps opening.	Excessive pressure in the circuit.	▶ Check the circuit pressure. ▶ Check the functioning of the pressure reducer. ▶ Check the settings of the pressure reducer.
	Problem with heating system expansion vessel.	▶ Check the efficiency of the expansion vessel.
There are traces of condensate on the rear head.	Flue gas box seals.	▶ Check the seals between the rear head and the flue gas box.

Table 22 Troubleshooting

11 Environmental protection/disposal

Environmental protection is one of the fundamental company policies of the Bosch Group. We regard quality of performance, economy and environmental protection as equal objectives.

Environmental protection laws and regulations are strictly adhered to. To protect the environment, we use the best possible technology and materials taking into account economic points of view.

Packaging

For the packaging, we participate in the country-specific recycling systems, which guarantee optimal recycling. All packaging materials used are environmentally-friendly and recyclable.

Old appliances

Old appliances contain resources that should be recycled.

The components are easy to separate and the plastics are marked. This allows the various components to be sorted for appropriate recycling or disposal.

12 Glossary

Appearance

The appearance of water depends on the presence of sediment, in suspension or in colloidal form, and on the presence of dissolved substances that create easily identifiable conditions like turbidity, colouration or foaming. These substances can lead to limescale, sludge, corrosion, abrasion, microbial growth and foaming.

Their presence in a heating system indicates either that the filling water has not been sufficiently purified and has been topped up, or that there are problems inside the circuit, (such as corrosion, leaks, etc.). It is essential to identify the source of any such impurities so that the correct remedial action can be taken.

Temperature

The temperature reached at different points in a heating circuit is extremely important, since it determines whether phenomena like limescale, corrosion and microbial growth will occur and how quickly they will develop. Temperature must be accurately specified at all stages of the system design process, and must be checked carefully as soon as any malfunctioning is detected.

pH

The pH value, referred to 77 °F (25°C), expresses how acidic or basic a solution is, in a scale from 0 to 14.

- 0 defines maximum acidity
- 7 defines neutrality
- 14 defines maximum basicity

pH is a fundamental parameter in evaluating how corrosive system water might be. It also represents an extremely important factor in the development of limescale, corrosion and microbial growth. Generally speaking, any pH value lower than the range specified in the Characteristics of filling and refilling water section can cause generalized corrosion, while any pH higher than that range can lead to limescale, sludge and corrosion.

Fixed residues at 180 °F – Electrical conductivity

Fixed residue offers a direct measurement by weight of the quantity of salts contained in a sample of water evaporated at 180 °F.

Since the electrical conductivity of a water based solution depends largely on its salt content, electrical conductivity is often taken as an alternative measurement to fixed residue. Since conductivity is also influenced by temperature, any measurement taken with a conductivity meter must be referred to 77 °F (25°C). Conductivity is expressed in microsiemens per centimetre ($\mu\text{S}/\text{cm}$).

As a practical means of measurement, it is assumed that fixed residue (expressed in mg/kg) corresponds to about 2/3 of the corresponding conductivity measurement (in $\mu\text{S}/\text{cm}$).

A high salt content can cause limescale, corrosion and sludge, and can also point to design errors or poor operating practices (e.g. insufficient bleeding) of the heating system or water treatment system.

Hardness

The total hardness of a water sample is an expression of the sum total of all the calcium and magnesium salts dissolved in it. The temporary hardness value expresses the sum total only of calcium and magnesium bicarbonates. Hardness is expressed in mg/kg of CaCO_3 or in degrees 'French' (1°fr = 10 mg/kg CaCO_3).

The use of hard water without suitable treatment can lead to the formation of limescale.

Alkalinity

M-alkalinity or total alkalinity represents the sum total of all alkaline salts (bicarbonates, carbonates, hydrates and alkaline phosphates) present in a water sample. P-alkalinity or phenolphthalein alkalinity expresses the content of hydrates and half the carbonates. The phenolphthalein alkalinity of naturally occurring water is normally zero. Alkalinity is expressed in mg/kg of CaCO_3 .

High P-alkalinity values can lead to increases in pH, and are generally caused by inadequate venting and bleeding.

Iron

Free iron in a water circuit can lead to sludge and/or secondary forms of corrosion. If the iron content of the raw water supply exceeds the established limits, suitable pretreatment must be provided. Iron found in system water as the result of corrosion points to the fact that the heating system or the treatment system is not being operated properly.

Copper

Copper content is expressed in mg/kg of Cu.

The presence of copper in system water can cause dangerous localized corrosion. Copper is seldom found in any appreciable quantity in raw water.

If it is detected, it is therefore the result of corrosive processes inside the heating circuit.

It may only be necessary to measure the copper content of the water if the system contains copper components which might be corroding.

Chlorides and sulphates

These values are expressed in mg/kg of Cl and SO_4 , respectively.

Since the system filling water is considered to be drinkable, no specific limits are laid down for chloride and sulphate content. These salts can nevertheless cause corrosion if they come into contact with certain metals (certain stainless steels in the case of chlorides and copper in the case of sulphates).

Microbial growth

A wide range of algae, fungus, mould and bacteria species can live and breed inside heating circuits. These microbes not only form living colonies of organisms but also cause corrosion and bad smells when they die and decompose.



This document only defines the intrinsic characteristics of water used in heating systems in order to identify suitable treatments. Failure to do so can lead to a wide range of problems.

Microbial growth

In this context, the term 'microbial' refers to any form of organic life normally classified as algae, fungi, moulds and bacteria.

Their growth is fed by light, heat, sludge and accidental pollution.

Perhaps the most dangerous microbes for a heating system are autotrophic bacteria (e.g. ferrobacteria and sulphate reducing bacteria). These are one of the direct causes of localized corrosion.

Microbial growth can be prevented by using suitable biocides.

Checks

As is the case with checks for water parameters, it is the responsibility of the system operator to ensure that any water treatment systems are functioning properly, in compliance with instructions and at the specified intervals. The supplier's responsibility ends with the supply and commissioning of the right conditioning system for achieving and maintaining the required water parameters.

Advice on sampling

In order to arrive at a correct analysis of the chemical and physical characteristics of a water sample, sampling systems and methods must be capable of guaranteeing precision and repeatability.

The sampling system must, in addition, not add further contaminants to the sample.

For this reason it is preferable for the sampling system to be made from the same material as the pipe or tank in which it is installed. If the temperature of the water being sampled is hotter than 95 °F (35°C), a cooling coil must also be provided to reduce its temperature to no more than 77 °F (25°C). Before taking the sample of water for testing, bleed the sampling system for 5 minutes to eliminate any oxides or other materials in suspension that might have accumulated in it.

The sample container must likewise be made from an inert material compatible with the sample collected (e.g. glass or polyethylene).

Wash any containers thoroughly in the water to be sampled before actually taking the sample.

Ordinary analysis and checking, frequency and sampling points

The following symbols and terms are used to identify sampling frequency and the location of sampling points:

Symbols and terms	
Frequency of analysis	A - Twice a year, in the season in which the heating system is in use
	B - Once a month
	C - Once every 15 days
	D - Once a week
Sampling points	1 - Filling water
	2 - Filling and/or refilling water
	3 - Water in the boiler or heating circuit

Table 23 Symbols and terms

The following table lists the sampling frequencies and sampling locations for the various types of heating system.

Type of system analysis and checks	Hot water heating system	Notes
Appearance	2A - 3A	
pH	3A	
Total hardness	2B	
Fixed residue		Electrical conductivity measurement can be used instead
Electrical conductivity		Fixed residue measurement can be used instead
Iron	3A	
P-alkalinity		
Chemical conditioner	3A	
Copper	3A	

Table 24 Sampling frequencies and sampling locations

Index

C

Checking and correcting the water pressure	34
Checking and correcting the water pressure in sealed unvented systems	35
Commissioning	
Commissioning the burner	30
Commissioning the control unit	30
Filling the heating system	30
Flushing the heating system	29
Preparing the heating system for operation	30
Commissioning report	31

D

Disposal	46
----------------	----

E

Environmental protection	46
--------------------------------	----

F

Filling the heating system	30
Fitting sensors	29
Flushing the heating system	29

I

Inspection and maintenance	
Checking and correcting the water pressure	34
Checking and correcting the water pressure in sealed unvented systems	35
Inspection report	36
Installation	
Fitting sensors	29

M

Maintenance report	36
--------------------------	----

O

Old appliances	46
----------------------	----

P

Packaging	46
Preparing the heating system for operation	30

R

Recycling	46
-----------------	----

S

Setting parameters	30
Shutting down	32
Heating system	32
In case of emergency	32

T

Temperature sensor	29
--------------------------	----

W

Water pressure	34
----------------------	----

Notes

Notes

United States and Canada

Bosch Thermotechnology Corp.
50 Wentworth Avenue
Londonderry, NH 03053
Tel. 603-552-1100
Fax 603-965-7581
www.bosch-climate.us
U.S.A.

Bosch Thermotechnology Corp. reserves the right to make changes without notice due to continuing engineering and technological advances.