

Installation and Service Instructions

Low-temperature oil/gas boiler

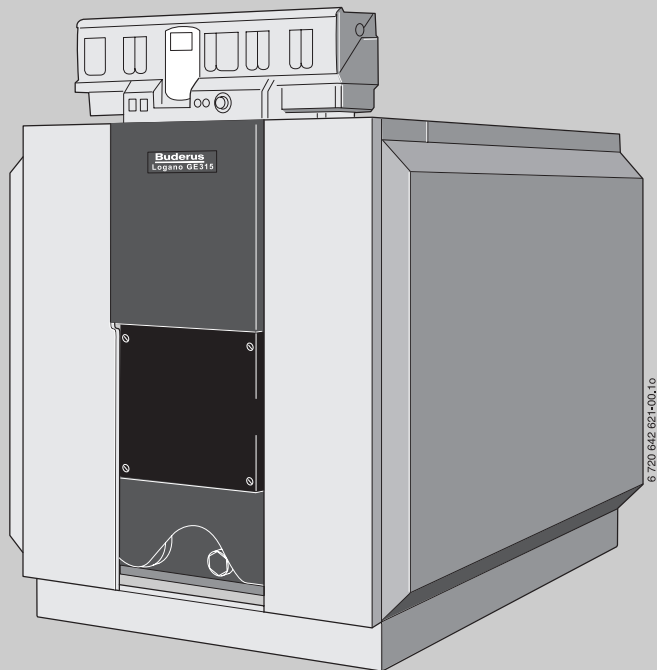

WARNING: If installation, adjustment, modification, operation or maintenance of the heating system is carried out by an unqualified person, this may result in personal injury or property damage.

The directions of this installation manual must be followed precisely.

If support or additional information is required, contact a qualified service company, service provider or the gas company.

WARNING:

Observe the safety instructions of this installation manual before placing the heating appliance in operation.

The operating manual is a component of the technical documentation and must be handed over to the operator of the heating system. Explain to the owner or operator how to use the heating system using the operating instructions. Make sure that he has been familiarized with all information required for the operation of the heating system.

NOTICE: If the heating appliance will be installed in Massachusetts, it must be installed by an installer or dealer who is registered there.

This manual is available in the English and French language.

Please keep this manual for future reference.

Logano G315

Boilers for oil/gas-fired power burners

For contractors

Read carefully prior to installation and maintenance

6 720 647 211 (1/2/2010) US/CA



Buderus

About this manual



The appliance has been tested to meet all national requirements in effect on the date of manufacture. The conformity has been confirmed. The corresponding documentation and the original Declaration of Conformity are on file with the manufacturer.

This installation and maintenance instructions contain important information for the safe and proper installation, initial start-up and maintenance of the oil/gas-fired boiler Logano G315.

These installation and maintenance instructions are designed for specialists, who, due to their vocational training and experience, are knowledgeable in handling heating systems and oil and gas installations.

The oil/gas-fired boiler Logano G315 is available in two variants (disassembled and assembled).

These installation and maintenance instructions explain the installation and maintenance of both boiler types.

Contents

1	Guideline to symbols and safety instructions	4
1.1	Explanation of symbols	4
1.2	Safety instructions	4
2	Product description	6
2.1	Designated use	7
2.2	Operating conditions	8
2.3	Compliance with standards and regulations	8
2.4	Additional regulations for installations in the Commonwealth of Massachusetts	10
3	Specifications	11
4	Scope of delivery	14
4.1	Logano G315 - delivery as a pre-assembled block	14
4.2	Logano G315 – delivery unassembled	14
5	Transporting the boiler	14
6	Positioning the boiler	15
6.1	Tools and auxiliary materials	15
6.1.1	Boiler assembly tool size 2.3	15
6.2	Recommended wall clearances	16
6.3	Installing the boiler on a boiler base or foundation	17
7	Boiler block assembly	18
7.1	Assembly of a boiler block from sections	18
7.2	Joining the boiler block assembly (delivery unassembled)	19
7.3	Setting up the boiler block (assembled block)	23
7.4	Sliding the supply pipe into place	24
7.5	Sealing the immersion sleeve	24
7.6	Leak test	25
7.6.1	Carrying out leak test	25
7.6.2	Sealing leaks	25
7.6.3	Supply flange with safety components, return flange	26
7.7	Boiler water connections	26

7.8	Installing fittings and burner door	27		
7.8.1	Positioning the draft diverter	27		
7.8.2	Screwing cleanout cover onto rear section	27		
7.8.3	Inserting the flue gas baffle plates	28		
7.8.4	Fitting burner door panel	28		
7.9	Boiler outer casing	29		
7.9.1	Fitting the profile rails	29		
7.9.2	Attaching the thermal insulation	29		
7.9.3	Fitting side panels and top covers	31		
<hr/>				
8	Connecting the boiler on the flue gas side	33		
8.1	Installing a vent pipe sealing collar (accessory)	33		
8.1.1	Installing a flue gas temperature sensor (accessory)	33		
<hr/>				
9	Installing the control panel	34		
9.1	Installing the control panel	34		
9.2	Fitting temperature sensor assembly . . .	34		
<hr/>				
10	Mounting the burner	36		
<hr/>				
11	System start-up	37		
11.1	Filling the system	37		
11.2	Commissioning the system	38		
11.3	Start up the control panel	38		
11.4	Initial burner start-up	38		
11.5	Raising flue gas temperature	38		
11.6	Commissioning log	39		
<hr/>				
12	Shutting down the system	40		
12.1	Shutting down the heating system via the control panel	40		
12.2	Shutting down the system in an emergency	40		
<hr/>				
13	System inspection and maintenance	41		
13.1	General information	41		
13.2	Why is regular maintenance important?	41		
13.3	Cleaning the boiler with cleaning brushes	41		
13.4	Wet-cleaning the boiler	43		
13.5	Checking the operating pressure	44		
13.6	Refilling with boiler water and purging the system	45		
13.7	Inspection and maintenance reports	46		

14	Troubleshooting burner faults	50
<hr/>		
15	Spare parts	51
<hr/>		
	Index	65
<hr/>		
	Appendix	66

1 Guideline to symbols and safety instructions

1.1 Explanation of symbols

Warnings



Warnings are indicated in the text by a warning triangle and a gray background.



In case of danger from electric shock, the exclamation point on the warning triangle is replaced with a lightning symbol.

Signal words at the beginning of a warning are used to indicate the type and seriousness of the ensuing risk if measures for minimizing damage are not taken.

- **NOTICE** indicates that material losses may occur.
- **CAUTION** indicates that minor to medium injury may occur.
- **WARNING** indicates possible severe personal injury.
- **DANGER** indicates a risk to life.

Important information



Important information that presents no risk to people or property is indicated with this symbol. It is separated by horizontal lines above and below the text.

Additional symbols

Symbol	Function
▶	Sequence of steps
→	Cross-reference to other points in this document or to other documents
•	Listing/list entry
–	Listing/list entry (2nd level)

Tab. 1

1.2 Safety instructions

Danger from failing to consider your own safety in an emergency such as a fire

- ▶ Never risk your own life. Your own safety must always take the highest priority.

Risk due to oil leaks

- ▶ When using oil as the fuel, national regulations hold the operator responsible for immediately asking a specialist contractor to remedy oil leaks the moment they are discovered.

If you smell gas

- ▶ Close the gas shut-off valve.
- ▶ If you hear gas escaping, evacuate the affected area immediately.
- ▶ Open the windows.
- ▶ Do not operate any electrical switches or equipment such as telephones, power plugs and doorbells.
- ▶ Extinguish all open flames.
- ▶ Do not smoke.
Do not use lighters.
- ▶ Warn all occupants of the building, but do not ring doorbells.
- ▶ Call your gas utility company and your local heating contractor **from outside the building**. If necessary, notify police or the fire department.

If you smell flue gas

- ▶ Switch OFF the appliance.
- ▶ Open windows and doors.
- ▶ Inform a trained and certified heating contractor.

Danger of electric shock when the control panel is open

- ▶ Always de-energize the connection before working on electrical parts (circuit breaker). Take measures to prevent accidental reconnection.
- ▶ Take provisions against unintentional reconnection.

Danger of poisoning from flue gas if supply of combustion air is insufficient

- ▶ Safeguard supply of combustion air.
- ▶ Do not cover or reduce the size of ventilation openings in doors, windows and walls.
- ▶ Safeguard sufficient supply of combustion air also for appliances installed at a later date, e.g. kitchen exhaust fans, clothes dryers, and air conditioning units with vent to the outside.
- ▶ Never operate the appliance if the supply of combustion air is insufficient.

Combustion air / room air

To prevent corrosion, keep the supply of combustion air / room air free of corrosive substances (e.g. halogenated hydrocarbons that contain chlorine or fluorine compounds).

Danger of explosion of flammable gases

- ▶ Only employ a trained and certified contractor to carry out work on the gas train.

Explosive and easily combustible materials

Never use or store easily combustible materials (paper, thinners, paints, etc.) near the appliance.

Installation, conversion

Only have the appliance installed or modified by a trained and certified heating contractor.

Never modify any parts that carry flue gas.

Never close the outlet of safety valves. Water may be expelled from any safety valve during heat-up.

Inspection and maintenance

The operator is responsible for safety and environmental compliance of the heating system.

Sign a maintenance and inspection contract with a trained and certified contractor, covering an annual inspection and demand-dependent maintenance. This guarantees high efficiency and environmentally sound combustion.

Instructing the customer

- ▶ Instruct customers about the functions and operation of the appliance.
- ▶ Inform the customer that they must not carry out any modifications or repairs.
- ▶ Only use the boiler for its intended purpose and only when it is in working order.

Disposal

- ▶ Dispose of packaging in an environmentally responsible manner.
- ▶ All heating system components that have to be replaced should be disposed of in environmentally-responsible manner at an authorized disposal site.

Other important information

- ▶ If the system overheats or the gas supply does not shut off, do not switch off or disconnect the power supply to the pump. Instead, shut off the gas supply somewhere else separate from the heating system.

2 Product description



NOTICE: Risk of system damage from use of incorrect burner.

- ▶ Only use burners that meet the technical requirements of the oil/gas-fired boiler Logano G315 (→ chapter 3, page 11).

The oil/gas-fired boiler Logano G315 has been developed and built employing the latest technologies and safety regulations.

Particular emphasis is placed on ease of operation. Please observe the safety instructions and the operating instructions to ensure optimum safe, economical and environmentally-friendly utilization of your system.

The main components of the Logano G315 oil/gas-fired boiler are:

- Boiler block (→ Fig. 1, [3])
The boiler block transfers the heat generated by the burner to the boiler water.
- Boiler shell (jacket → Fig 1 and 2, [1]), thermal insulation (→ Fig 1, [2])
The boiler jacket and thermal insulation minimize energy loss.
- Control panel (→ Fig 1, [4])
The control panel is designed to monitor and control all electrical components of the oil/gas-fired boiler Logano G315.



Observe all standards and guidelines applicable to the installation and operation of the system in your country.

Please observe the information on the boiler rating plate. These are definitive and must be observed.



To prevent boiler contamination, we recommend installing a dirt trap in the water system.



As a basic rule, flush existing systems before connecting the boiler.

Install a desludging unit in the boiler return to prevent damage to the boiler.

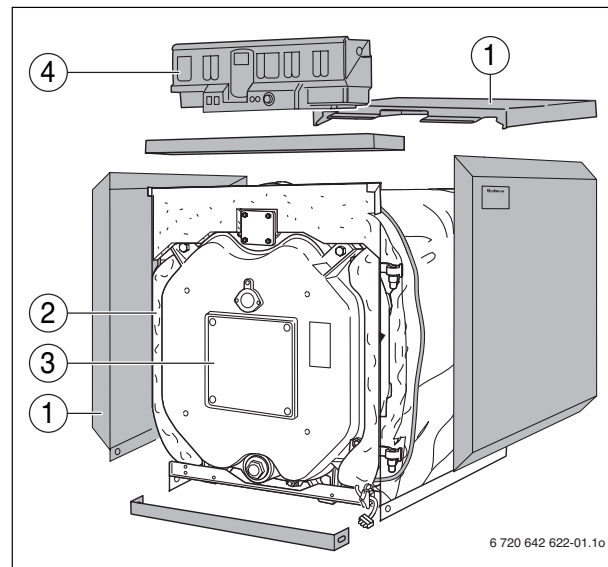

Fig. 1 Oil/gas-fired boiler Logano G315

- 1 Boiler shell (jacket)
- 2 Thermal insulation
- 3 Boiler heat exchanger
- 4 Control Panel Assembly

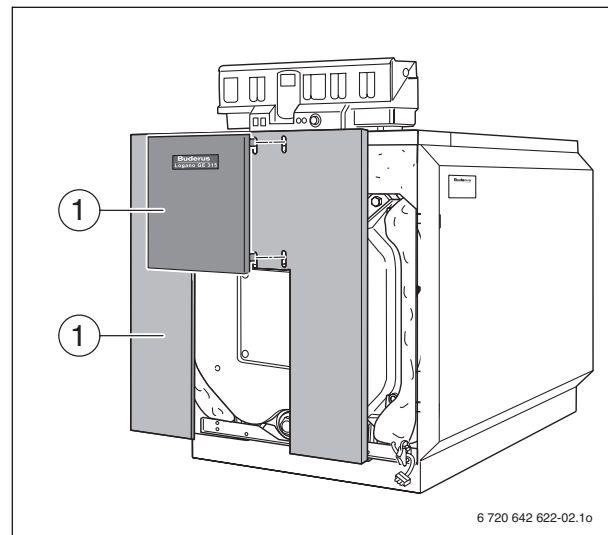

Fig. 2 Front jacket

- 1 Boiler shell (jacket)

Fuels			
Logano G315	Heating oil	Liquid propane (LPG)	Natural Gas (NG)
Remarks	<p>The Logano G315 boiler can be operated with the specified fuels. Select a burner suitable for use with the fuels specified for the Logano G315 boiler.</p> <p>The output figures shown in the Table "Technical Data" are nominal power figures.</p> <p>Carry out maintenance and cleaning procedures annually. Check that the entire system is functioning correctly.</p> <p>Immediately remedy faults.</p> <p>If heating oil is used, shorter maintenance intervals may be necessary depending on the operating time.</p>		

Tab. 2

2.1 Designated use

The Logano G315 oil/gas-fired boilers have been designed for the heating of water.

The Logano G315 can be operated with oil, gas, and combination burners. For a list of the approved burners, please contact Bosch Thermotechnology Corp.

This boiler can be operated with an aquastat, the Logamatic 4000, and other control systems.

2.2 Operating conditions

Thermostream technology is a unique feature of Buderus cast iron boilers. Return water is preheated and mixed within the boiler before it comes in contact with the heating surface of the combustion chamber. The Thermostream technology ensures there is an even temperature distribution in the boiler and avoids condensate forming within the combustion chamber. This unique feature reduces thermal stress, the main cause of

failure of traditional cast iron boilers. The advantage of this technology is the maintenance of the minimum operating temperature of the boiler (→ Tab. 3); this makes the installation of a shunt pump unnecessary. This way, the costs for the pump itself and its power consumption, as well as possible failure costs are saved. The minimum boiler operating temperature as shown in the table below must be reached within 10 minutes and then be maintained while the burner is running.

		Control of all heating zones with Buderus 4000	External controls (BMS) or Aquastat control
Minimum flow rate		none	
Minimum return temperature	°F (°C)	none	
Minimum operating temperature oil boiler ¹⁾	°F (°C)	122–(50)	
Minimum operating temperature gas boiler ¹⁾	°F (°C)	122–(50) ²⁾	140–(60) ²⁾
Maximum supply temperature	°F (°C)	212 ³⁾ /248 ⁴⁾ (100 ³⁾ /120 ⁴⁾)	
Maximum operating pressure	PSI (bar)	87–(6)	
For operation with two-stage oil and gas burners	–	Set the partial load stage to 60 %	
Time constant of the temperature controller	sec	40	
Time constant of the monitor/limiter	sec	40	

Tab. 3

- 1) This temperature has to be reached within ten minutes of the burner starting and has to be maintained whilst the burner is firing.
- 2) 65 °C with partial load < 60 %
- 3) The maximum supply temperature is 212 °F (100 °C), if the boiler is operated as hot water boiler.
- 4) The maximum supply temperature is 248 °F (120 °C), if the boiler is operated as a hot water generator.



A heating zone with a mixing valve improves controllability and is specifically recommended for systems with differing water temperature zones.

This operating condition can be easily achieved by the controls monitoring the boiler temperature and reducing the flow rate through the boiler until the required temperature is reached. This is then maintained by continuing to control flow based on the boiler water temperature. The controls can reduce the flow rate by closing the valves on the mixed heating circuits, modulating the boiler primary pumps, closing the motorized butterfly valves or by having a motorized valve in the boiler return on a single boiler installation. The Buderus 4000 series controls can manage this process or it can be completed by the BMS.

If it is not possible for the control panel to regulate the flow sufficiently to meet this operating condition, then a shunt pump circuit must be fitted to avoid the type of thermal stress that all boilers would experience in these conditions. This shunt pump circuit can be controlled either with a Buderus 4000 control panel or with a third-party controller. Failure to ensure that the operating condition is maintained may lead to thermal stress in the boiler and eventual failure of the sections which would be outside the scope of the warranty.

2.3 Compliance with standards and regulations

Installation and operation of the system must comply with all applicable codes, regulations and statutory requirements.

Installation, connection of the fuel supply and flue connector, commissioning, connection of the electrical power supply, servicing and repair may only be carried out by a trained or certified heating contractor. Only registered gas fitters may carry out work on the gas train.

The system must be cleaned and serviced once a year. The operation of the complete system must be tested at the same time. Any faults must be corrected immediately.

The design and mode of operation of this boiler must comply with the American National Standard ANSI Z21.13/CSA4.9, latest edition for Gas Fired Low Pressure Steam and Hot Water Boilers.

Other confirmed approvals and certifications are indicated by labels on the boiler.

The heat exchanger has been designed and certified in accordance with the ASME Boiler and Vessel Code, Section IV.

Installation of the boiler must comply with all applicable codes and regulations imposed by the national, Federal or local authorities and bodies. If no specific requirements are defined, in the USA, the latest edition of the National Fuel Gas Code ANSI Z223.1/NFPA 54 applies. In Canada, installation must comply in all respects with the latest edition of the Installation Code for Gas Burning Appliances and Equipment, CAN/CSA-B.149 and the applicable local regulations and requirements for the appliance category. The relevant authorities and regulatory bodies must be informed before installation starts.

Where required by local regulations, the system must comply with the American Society of Mechanical Engineers Safety Code for Controls and Safety Devices for Automatically Fired Boilers (ASME CSD-1).

The hot water distribution system must comply with all applicable codes and regulations. When replacing an existing boiler, it is important to check the condition of the entire hot water distribution system to ensure safe operation.

In the Commonwealth of Massachusetts, this appliance must be installed by a licensed plumber and gas fitter. Valves external to the boiler must be fitted with T-handles and condensate piping must be installed in accordance with the State Plumbing Code.

2.4 Additional regulations for installations in the Commonwealth of Massachusetts

(a) For all side wall horizontally vented gas fueled equipment installed in every dwelling, building or structure used in whole or in part for residential purposes, including those owned or operated by the Commonwealth and where the side wall exhaust vent termination is less than seven (7) feet above finished grade in the area of the venting, including but not limited to decks and porches, the following requirements shall be satisfied:

- **INSTALLATION OF CARBON MONOXIDE DETECTORS.** At the time of installation of the side wall horizontal vented gas fueled equipment, the installing plumber or gasfitter shall observe that a hard wired carbon monoxide detector with an alarm and battery back-up is installed on the floor level where the gas equipment is to be installed. In addition, the installing plumber or gasfitter shall observe that a battery operated or hard wired carbon monoxide detector with an alarm is installed on each additional level of the dwelling, building or structure served by the side wall horizontal vented gas fueled equipment. It shall be the responsibility of the property owner to secure the services of qualified licensed professionals for the installation of hard wired carbon monoxide detectors.
 - In the event that the side wall horizontally vented gas fueled equipment is installed in a crawl space or an attic, the hard wired carbon monoxide detector with alarm and battery back-up may be installed on the next adjacent floor level.
 - In the event that the requirements of this subdivision cannot be met at the time of completion of installation, the owner shall have a period of thirty (30) days to comply with the above requirements; provided, however, that during said thirty (30) day period, a battery operated carbon monoxide detector with an alarm shall be installed.
- **APPROVED CARBON MONOXIDE DETECTORS.** Each carbon monoxide detector as required in accordance with the above provisions shall comply with NPA 720 and be ANSI/UL 2034 listed and IAS certified.
- **SIGNAGE.** A metal or plastic identification plate shall be permanently mounted to the exterior of the building at a minimum height of eight (8) feet above grade directly in line with the exhaust vent terminal for the horizontally vented gas fueled heating appliance or equipment. The sign shall read, in print size no less than one-half (1/2) inch in size, "GAS VENT DIRECTLY BELOW. KEEP CLEAR OF ALL OBSTRUCTIONS".

- **INSPECTION.** The state or local gas inspector of the side wall horizontally vented gas fueled equipment shall not approve the installation unless, upon inspections, the inspector observes carbon monoxide detectors and signage installed in accordance with the provisions of 248 CRM 5.08(2)(a) 1 through 4.

(b) EXEMPTIONS: The following equipment is exempt from 248 CRM 5.08(2)(a) 1 through 4:

- The equipment listed in Section 10 entitled "Equipment Not Required To Be Vented" in the most current edition of NFPA 54 as adopted by the board; and
- Product Approved side wall horizontally vented gas fueled equipment installed in a room or structure separate from the dwelling, building or structure used in whole or in part for residential purposes.

(c) MANUFACTURERS REQUIREMENTS - GAS EQUIPMENT VENTING SYSTEM REQUIRED. When the manufacturer of Product Approved side wall horizontally mounted gas equipment provides a venting system design or venting system components with the equipment, the instructions provided by the manufacturer for the installation of the equipment and venting shall include:

- Detailed instructions for the installation of the venting system or the venting system components; and
- A complete parts list for the venting system design or venting system.

(d) MANUFACTURERS REQUIREMENTS - GAS EQUIPMENT VENTING SYSTEM NOT PROVIDED. When the manufacturer of Product Approved side wall horizontally vented gas fueled equipment does not provide the parts for the venting of flue gases, but identifies "special venting systems", the following requirements shall be satisfied by the manufacturer:

- The referenced "special venting systems" shall be included with the appliance or equipment installation instructions; and
- The "special venting systems" shall be Product Approved by the Board, and the instructions for that system shall include a parts list and detailed installation instructions.

(e) A copy of all instructions for all Product Approved side wall horizontally vented gas fueled equipment, all venting instructions, all parts lists for venting instructions, and/or venting design instructions shall remain with the appliance or equipment at the completion of the installation.

3 Specifications

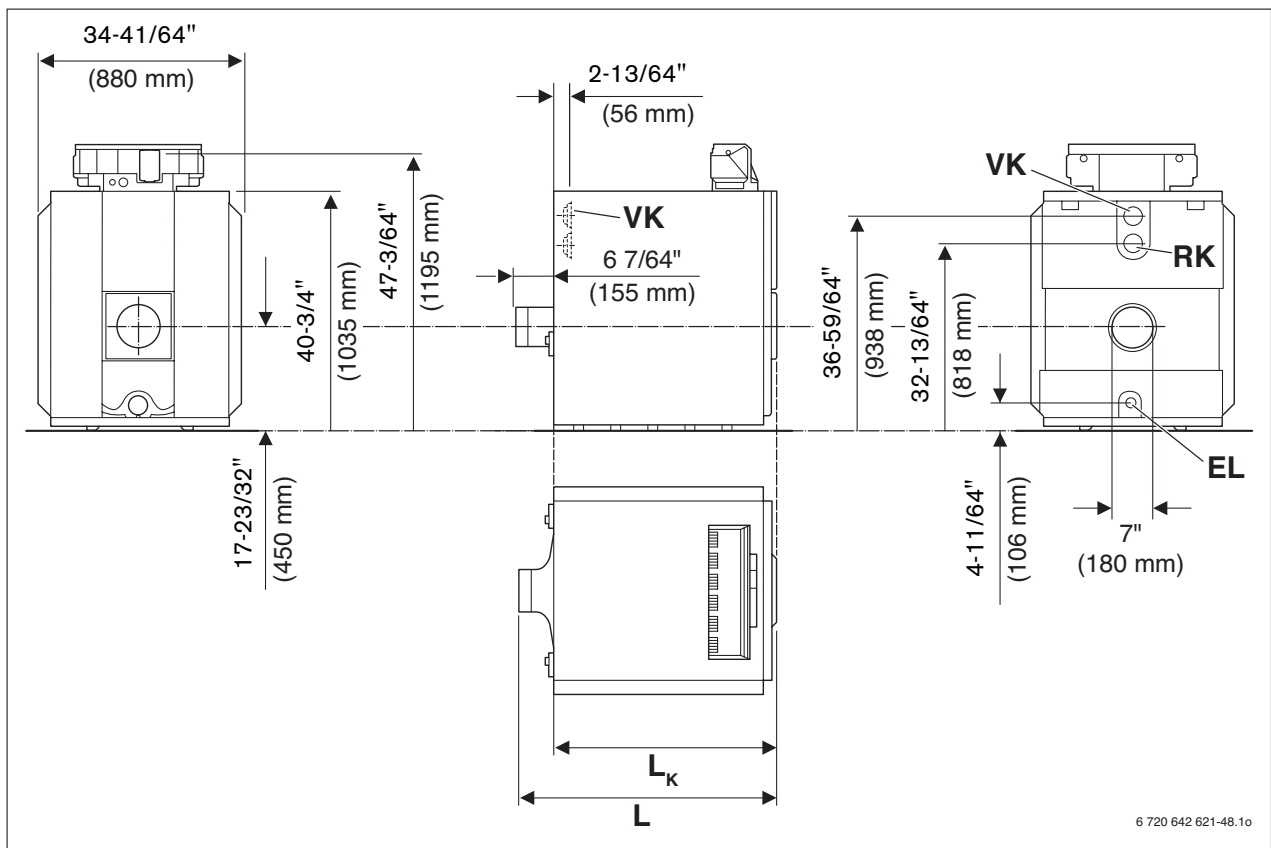

Fig. 3 Technical data for Logano G315 (dimensions in inches (mm))

- EL** Drain valve (Rp $\frac{3}{4}$)¹⁾
- L_K** Boiler heat exchanger length
- L** Overall boiler length
- RK** Return connection on the boiler²⁾
- VK** Supply connection on the boiler³⁾

1) With the drain valve (EL), you may only drain the system, not fill it.

2) The filling of the boiler and the system must be undertaken on a separate connector on the return line.

3) The flange corresponds to the order reduced to 212 (DN100), 176 (DN80) or 149 (DN65).

3 Specifications

Logano G315						
Boiler capacity	Unit	105	140	170	200	230
Number of boiler sections	–	5	6	7	8	9
Nominal output	Btu/hr	293.500 – 358.000	362.000 – 477.800	481.000 – 580.200	583.600 – 682.600	686.000 – 784.990
	(kW)	(86 – 105)	(106 – 140)	(141 – 170)	(171 – 200)	(201 – 230)
Combustion output	Btu/hr	314.300 – 387.300	387.300 – 516.700	515.300 – 625.900	624.900 – 734.100	734.400 – 846.000
	(kW)	(92.1 – 113.5)	(113.5 – 151.4)	(151.0 – 183.4)	(183.1 – 215.1)	(215.2 – 247.9)
Boiler overall length (L)	inches	44-19/64	50-19/32	56-57/64	63-3/16	69-31/64
	(mm)	(1125)	(1285)	(1445)	(1605)	(1765)
Boiler block length (L _K)	inches	38-3/16	44-31/64	50-25/32	57-3/32	63-25/64
	(mm)	(970)	(1130)	(1290)	(1450)	(1610)
Fitting clearance, boiler section (width × height × depth)	inches	28-1/32 × 36-25/32 × 6-19/64				
	(mm)	(712 × 934 × 160)				
Fitting clearance, boiler block (width × height × length)	inches	28-1/32 × 39-1/8 × L _K				
	(mm)	(712 × 994 × L _K)				
Combustion chamber length	inches	31-7/64	37-13/32	43-45/64	50	56-19/64
	(mm)	(790)	(950)	(1110)	(1270)	(1430)
Combustion chamber diameter	inches	15 3/4				
	(mm)	(400)				
Burner door thickness	inches	4-59/64				
	(mm)	(125)				
Vent connection diameter	inches	7"				
	(mm)	(178)				
Weight, net ¹⁾	lb.	1.20	1.395	1.59	1.78	1.975
	(kg)	(543)	(631)	(719)	(807)	(895)
Boiler water content	gal.	37.75	45.25	52.5	60	67.5
	(l)	143	171	199	227	255
Gas capacity	gal.	38.83	47.82	56.8	65.78	69.48
	(l)	147	181	215	249	263
Flue gas temperature, partial load (60 %)	°F	178.6	280.4	176.8	269.6	285.8
	(°C)	(137)	(138)	(136)	(132)	(141)

Tab. 4

Logano G315						
Boiler capacity	Unit	105	140	170	200	230
Flue gas temperature, full load	°F (°C)	323.6 – 365 (162 – 185)	309.2 – 359.6 (154 – 182)	321.8 – 356 (161 – 180)	316.4 – 348.8 (158 – 176)	334.4 – 374 (168 – 190)
Flue gas mass flow rate, oil, partial load (60 %)	lb./s (kg/s)	0.0624 (0.0283)	0.0831 (0.0377)	0.101 (0.0458)	0.1188 (0.0539)	0.1367 (0.0620)
Flue gas mass flow rate oil, full load ²⁾	lb./s (kg/s)	0.0862 – 0.1063 (0.0391 – 0.0482)	0.1063 – 0.1418 (0.0482 – 0.0643)	0.1413 – 0.1717 (0.0641 – 0.0779)	0.1713 – 0.2013 (0.0777 – 0.0913)	0.2013 – 0.2319 (0.0913 – 0.1052)
Flue gas mass flow rate, gas, partial load (60%)	lb./s (kg/s)	0.0626 (0.0284)	0.0836 (0.0379)	0.1014 (0.0460)	0.1193 (0.0541)	0.1371 (0.0622)
Flue gas mass flow, gas, full load ²⁾	lb./s (kg/s)	0.0864 – 0.1067 (0.0392 – 0.0484)	0.1067 – 0.1422 (0.0484 – 0.0645)	0.1418 – 0.1722 (0.0643 – 0.0781)	0.172 – 0.2019 (0.0780 – 0.0916)	0.2022 – 0.2328 (0.0917 – 0.1056)
CO ₂ content, oil	%	13.0				
CO ₂ content, gas	%	10				
Required draft	PSI (Pa)	0 (0)				
Fireside pressure drop	in. W.C. (mbar)	0.112 – 0.165 (0.28 – 0.41)	0.185 – 0.317 (0.46 – 0.79)	0.285 – 0.522 (0.71 – 1.30)	0.538 – 0.715 (1.34 – 1.78)	0.530 – 0.711 (1.32 – 1.77)
Maximum permissible supply temperature ³⁾	°F (°C)	248 (120)				
Maximum permissible operating pressure	PSI (bar)	87 (6)				
						

Tab. 4

- 1) Weight with packaging approx. 6 – 8 % higher.
- 2) The details relate to the upper and lower rated output range.
- 3) Safety limit (high limit safety cut-out). Maximum possible supply temperature = safety limit (STB) – 32 °F (– 18 K).
Example: Safety limit (STB) = 212 °F (100 °C), max. possible supply temperature = 212 – 32 = 180 °F (100 – 18 = 82 °C).

4 Scope of delivery

The Logano G315 can be delivered either as a pre-assembled block or in loose sections.

- ▶ Check that the packaging is undamaged on delivery.
- ▶ Check that the delivery is complete.

4.1 Logano G315 - delivery as a pre-assembled block

Component	Qty	Packaging
Boiler block with burner door and supply pipe	1	Pallet
Jacket pack (according to boiler rating)	1	Cartons
Thermal insulation	1	bag

Tab. 5

4.2 Logano G315 – delivery unassembled

Component	Qty	Packaging
Front and rear section, 3 intermediate sections as well as burner door	1	Pallet
Intermediate sections – (depending on boiler size)	1	Pallet
Fittings and draft diverter	1	Box
Tie rods and supply pipe	1	Bundle
Jacket pack (according to boiler rating)	1	Cartons
Thermal insulation	1	Bag

Tab. 6

5 Transporting the boiler

Use suitable equipment to transport the individual boiler sections (delivery unassembled) and other individual parts.



WARNING: Risk of injury from improperly secured boiler sections.

- ▶ Use only suitable means of transportation when handling the boiler sections, e.g. a heavy duty hand truck.
- ▶ Secure the individual boiler sections to prevent them from sliding off during transport.



NOTICE: Risk of system damage from impacts.

- ▶ The standard delivery of the Logano G315 oil/gas-fired boiler contains components that are sensitive to shock.
- ▶ During handling protect all electronic and other components against impact.
- ▶ Please observe the transport instructions on the packaging.



NOTICE: Risk of system damage from contamination.

- ▶ If you intend to keep the boiler in storage once it has been assembled, observe the following:
- ▶ Protect the boiler connections against contamination by sealing them off or covering them.



Dispose of packaging in an environmentally responsible manner.

6 Positioning the boiler

This chapter describes how to properly position the Logano G315.



NOTICE: Risk of system damage from freezing.
▶ Install the system in a room free from the danger of freezing.

6.1 Tools and auxiliary materials

The following tools and auxiliary materials are required for the boiler assembly (the listed items must be provided by the installer):

- Boiler assembly tool 2.3 (→ Fig. 4)
- Installation kit (accessory)
- Steel hammer and wooden or rubber mallet
- Half-round bastard file
- Screwdriver (Philips and flat head)
- Flat chisel
- Metric wrenches
- Support wedge, flat iron
- Cleaning rags and cloth
- Fine emery cloth
- Wire brush
- 3-in-1 oil
- Solvent (gasoline, mineral spirits)
- Spirit level, tape measure, chalk, straight edge
- Blanking flange with vent facility (for pressure test)

6.1.1 Boiler assembly tool size 2.3

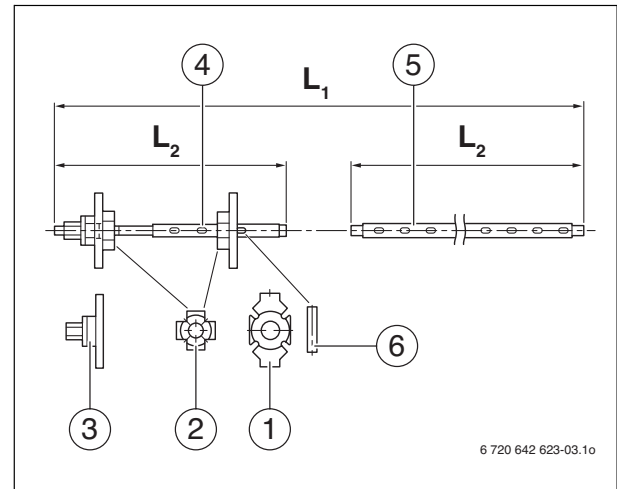

Fig. 4 Boiler assembly tool size 2.3

- 1 Mating flange
- 2 Additional flange
- 3 Compression unit (pressure flange with clamping nut)
- 4 Tie rod
- 5 Extension
- 6 Wedge (size 2.3)
- L₁ 121-1/4" (3080 mm)
- L₂ 31-1/2" (800 mm)

Boiler sections	Assembly tool(s) per boiler hub	Extension piece per boiler hub	Length (total) in inches (mm)
5 - 9	1	3	121-1/4 (3080 mm)

Tab. 7



For the correct arrangement of the flange when performing the assembly procedure, refer to page 22.

6.2 Recommended wall clearances

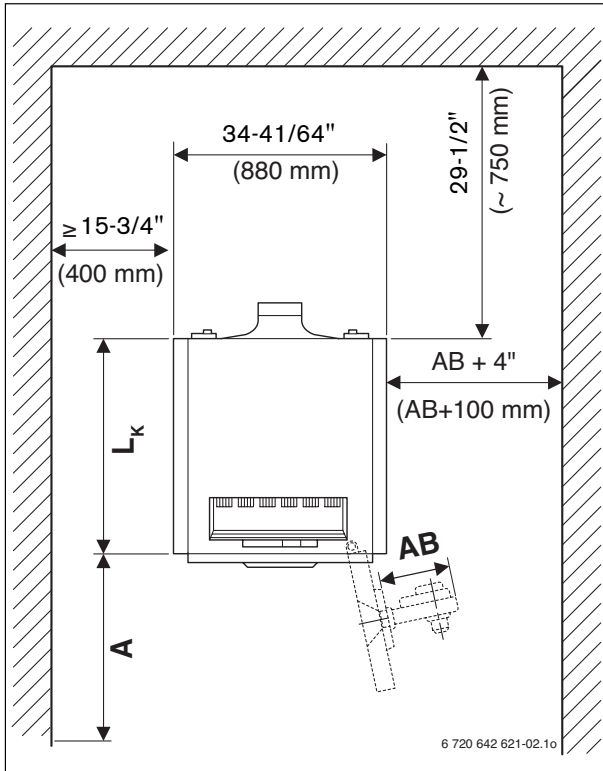

Fig. 5 Installation room with boiler

Observe the recommended wall clearances for complete opening of the burner door, for boiler installation and for cleaning and maintenance Fig. 5.

The burner door can be hung with the hinges on the right or left.

When installing your boiler maintain the recommended minimum dimensions. Select the recommended clearances between wall and boiler for easy access for installation, maintenance and service work.

The wall clearance on the hinge side must be at least the burner projection (AB). A distance of AB + 4 inches (AB + 100 mm) from the wall is recommended.

The length L_k depends on the number of boiler sections or boiler rating → Spare parts, page 51.

Boiler capacity		Clearance A in inches (mm)	
MBH (kW)	Boiler sections	Recommended	Minimum
358 – 686 (105 – 230)	5 – 9	59 (1500)	39-3/8 (1000)

Tab. 8

If you do not observe the recommended minimum clearance (→ Fig. 5), you will not be able to use the cleaning kit (accessory). Alternatively shorter cleaning devices or wet cleaning may be used.

6.3 Installing the boiler on a boiler base or foundation

When setting up the boiler, we recommend you observe the specified wall clearances for improved installation and maintenance (Fig. 5).

It is advisable to place the boiler on a 2 – 4 inch (50 – 80 mm) tall base (Fig. 6, [1]). The base should be completely flat and level. The front edge of the boiler should be flush with the edge of the base.



A silencing boiler base is available as optional equipment from **Buderus**.

If this optional boiler base is not used, a concrete foundation can be constructed on-site. When building the foundation, a 3 15/16 x 1 31/32 x 5/16 inches (100 x 50 x 8 mm) steel angle or 3 15/16 x 13/64 inches (100 x 5 mm) steel flat should be incorporated (→ Fig. 6 and Tab. 9).

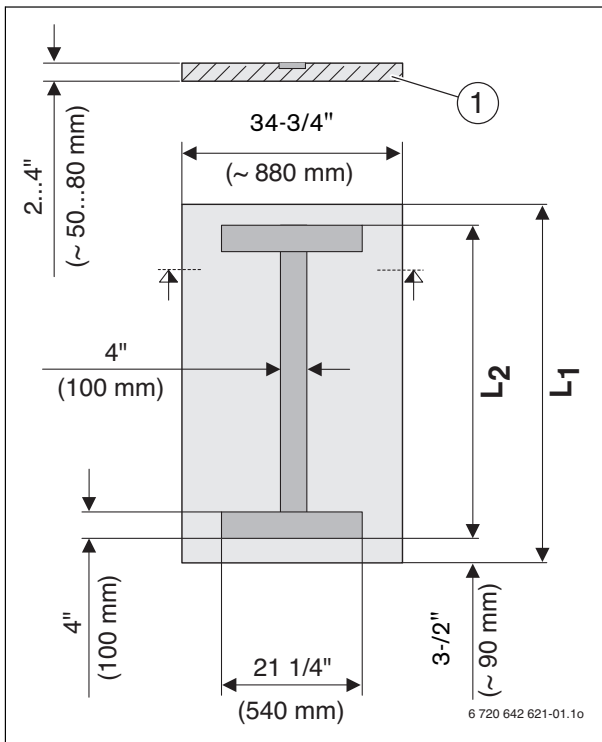

Fig. 6 Base dimensions

Number of boiler sections	L1 (base) in inch (mm)	L2 (steel section) in inch (mm)
5	38-3/16 (970)	28-3/4 (730)
6	44-31/64 (1130)	35-1/32 (890)
7	50-25/32 (1290)	41-21/64 (1050)
8	57-3/32 (1450)	47-41/64 (1210)
9	63-25/64 (1610)	53-15/16 (1370)

Tab. 9 Foundation dimensions and lengths of steel flats or steel angles

7 Boiler block assembly



WARNING: Risk of injury from improperly secured boiler sections.

- ▶ Use only suitable means of transportation when handling the boiler sections, e.g. a heavy duty hand truck. When handling, secure the boiler sections to the means of transport to prevent them slipping.

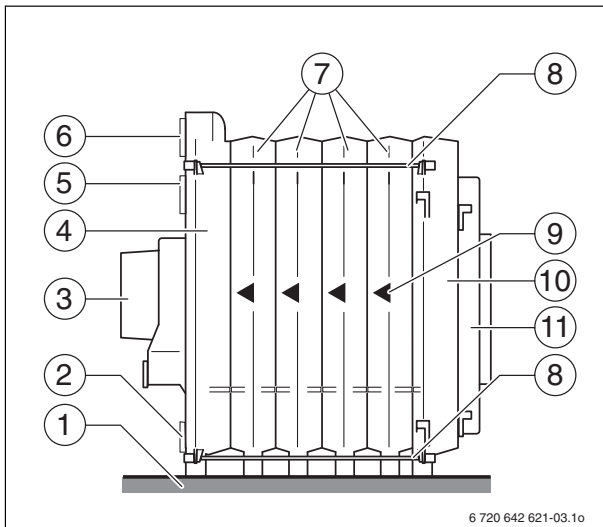

Fig. 7 Boiler heat exchanger

Key to Fig. 7:

- 1 Boiler base or foundation
- 2 Draining
- 3 Exhaust Manifold
- 4 Rear section
- 5 Return connection
- 6 Supply connection
- 7 Intermediate sections
- 8 Tie rod
- 9 Directional arrow
- 10 Front section
- 11 Burner door with burner plate

Depending on the type of delivery, we distinguish between delivery unassembled and as a **ready assembled block**. When delivered as a ready-assembled block, the boiler is assembled and checked for leaks prior to despatch. If, because of physical limitations, a boiler block cannot be assembled as a complete unit, delivery unassembled would enable assembly on site.

For **details of assembling the remainder of the boiler if the heat exchanger is delivered pre-assembled**, see → Chapter 7.3, page 23.

7.1 Assembly of a boiler block from sections



WARNING: Risk of injury from inadequately secured boiler sections.

- ▶ Secure boiler sections during assembly and take measures to prevent them from tipping over. If a hoisting tool is available, this can be used to set up the boiler sections safely.

The boiler block is always installed starting from the rear with the rear section (Fig. 7, [4]) and working towards the front. The front section (Fig. 7, [10]) is always fitted last.

Observe the directional arrows (Fig. 7, [9]) during assembly and carry this out in accordance with the following instructions and illustrations.

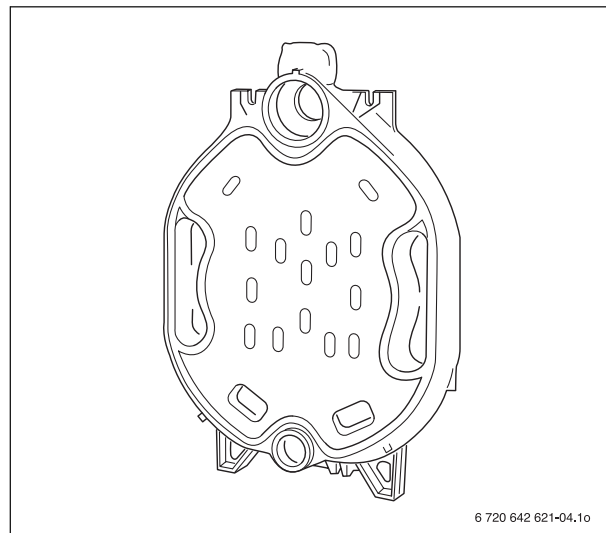

Fig. 8 Rear section

7.2 Joining the boiler block assembly (delivery unassembled)

Remove nuts and washers from the studs on the hubs of the boiler sections before attaching the rear section and front section.

- ▶ Set up the rear section and secure it against tipping.
- ▶ File down any burrs on the hubs (→ Fig. 9).

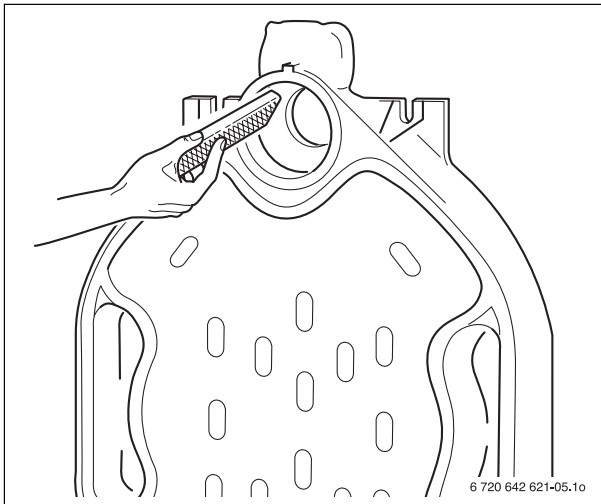



Fig. 9 Remove burrs

- ▶ Clean the packing grooves where required using a wire brush and cloth (Fig. 10, [3]).
- ▶ Clean the hub sealing faces (Fig. 10, [1 and 2]) with a rag soaked in solvents or gasoline.



WARNING: Health hazard from noxious vapors released from material handling, such as solvents, primers or sealant.

- ▶ Ensure adequate ventilation of the installation area.
- ▶ Please note the handling and safety instructions of the product used.

- ▶ Evenly coat the hub sealing faces with sealant.

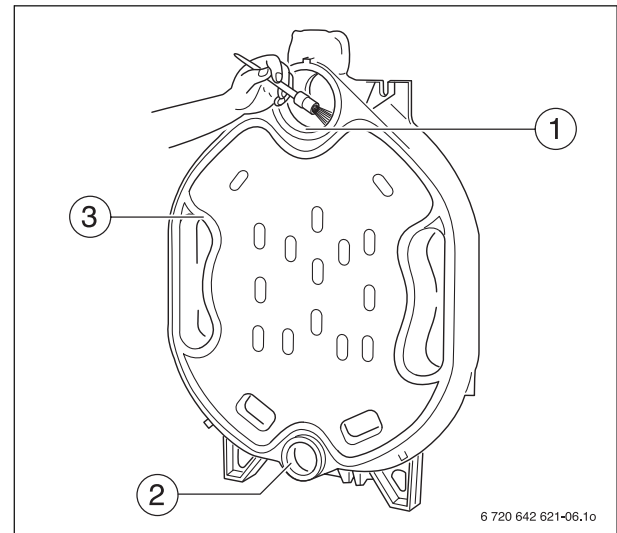

Fig. 10 Preparing the packing grooves and hubs

The next step involves preparing the nipples that will eventually seal the boiler sections.

- ▶ Clean nipple with a rag soaked in solvents or gasoline and coat evenly with sealant.
- ▶ Insert the nipple straight into the upper (Sz. 2,119/50) and lower (Sz. 0, 57/50) hub of the rear section and hammer home securely with alternate heavy blows. The upper nipple (Fig. 11, [1]) and the lower nipple (Fig. 11, [2]) should protrude approx. 28 mm out of the corresponding hub once they have been driven in.
- ▶ Remove any burrs with a file.

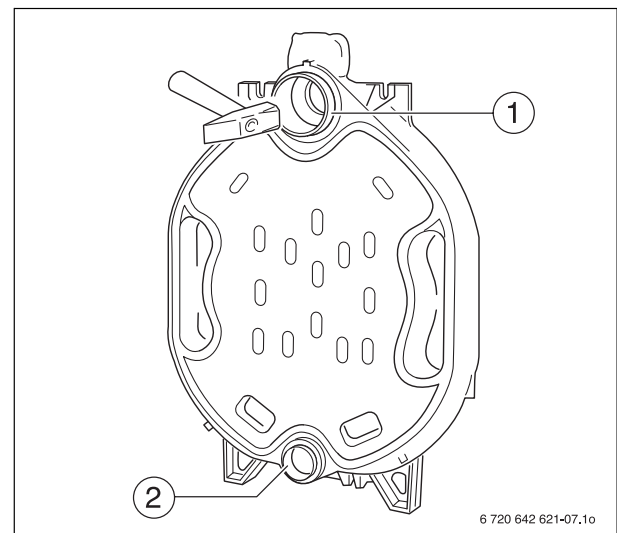

Fig. 11 Driving nipples home

The packing grooves (Fig. 12, [1]) must be clean and dry to enable the sealant rope to adhere properly.

- ▶ Coat the packing grooves with adhesive (primer).

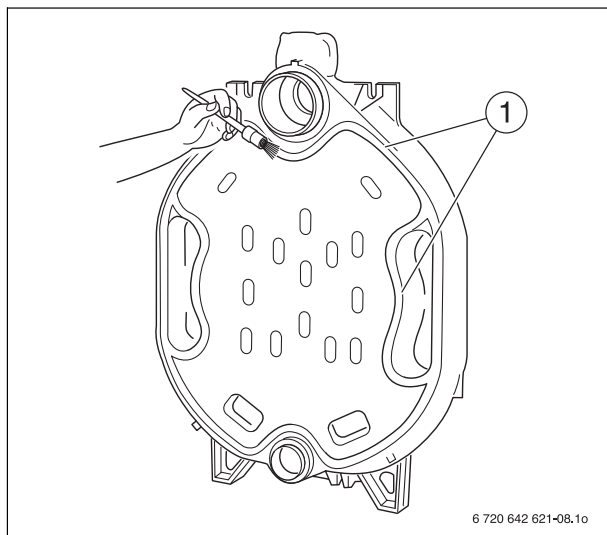

Fig. 12 Coat the packing grooves with adhesive

- ▶ Insert the flexible sealant rope (→ Fig. 13, [2]) on the front of the rear section, starting around the upper hub, into the packing grooves (→ Fig. 13, [1]) and press in lightly. At the butt joints, overlap the sealant rope by approx. 2 cm and press firmly together.
- ▶ Unroll the required length of sealant rope from the spool supplied.
- ▶ Peel the backing paper from the sealant rope when inserting into the packing groove (do not stretch).

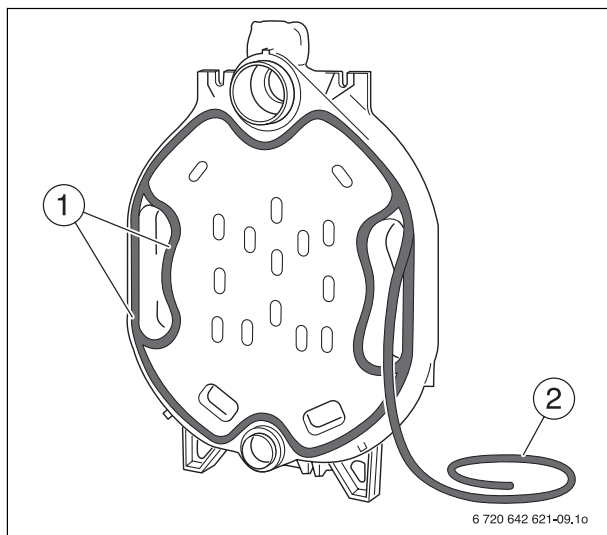

Fig. 13 Inserting sealant rope

Preparation of the first intermediate section:

- ▶ File down any burrs on the hubs (as shown in Fig. 9).
- ▶ The packing springs must be clean and dry. Clean if necessary.
- ▶ Clean the hub sealing faces with a rag soaked in solvents or gasoline.
- ▶ Evenly coat the hub sealing faces with sealant (Fig. 14, [1]).
- ▶ Coat the packing springs with adhesive (primer) (Fig. 14, [2]).

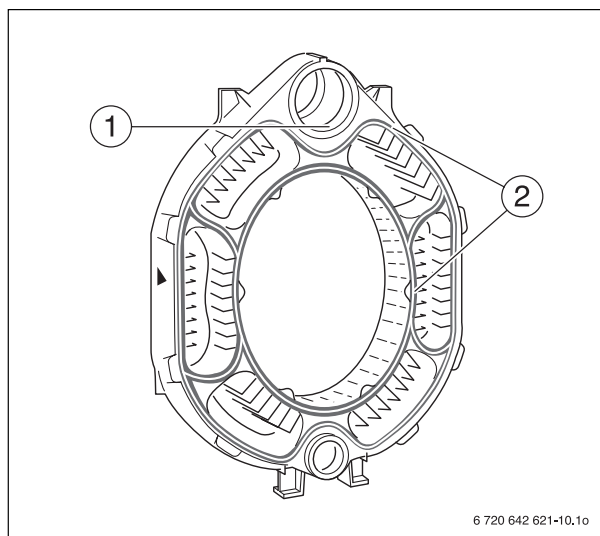

Fig. 14 Preparing the centre section



To make installation easier, place the boiler section to be fitted onto the nipple on the upper hub first. Once this has been done, the boiler section can be aligned with the lower hub.

The directional arrow (→ Fig. 15, [3]) must point in the direction of the rear boiler section.

- ▶ Position the intermediate section so that the upper and lower hubs (→ Fig. 15, [2 and 4]) fit onto the nipples in the rear section.
- ▶ Pound first intermediate section onto the rear section using a wooden or a rubber mallet (→ Fig. 15, [1]).

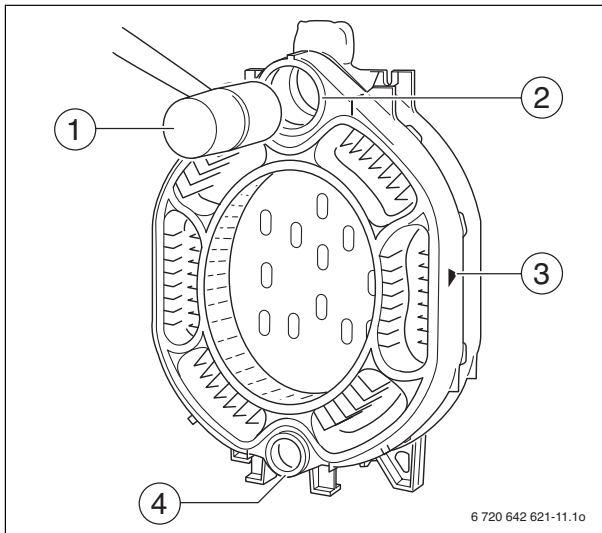

Fig. 15 Pound intermediate section in place



Before the nipples are inserted in the next intermediate section, the part-assembled boiler block must be compressed using the boiler assembly tool.



NOTICE: The boiler can be damaged by pulling the boiler sections together incorrectly or due to excessive compression.

- ▶ Ensure that the nipples are positioned straight in the boiler hubs after being pounded in and that they have not been compromised.
- ▶ Never compress more than one nipple joint at a time.
- ▶ Stop compressing the sections when the boiler hubs meet.



NOTICE: Assembly tool damage due to loose screw connections of the tie rods.

- ▶ Always check the tie rods before each use and retighten as necessary. The tie rod is correctly positioned if it is fully inserted and no threads are showing (→ Fig. 16, [2]).
- ▶ Always keep the threads (→ Fig. 16, [1]) clean. Dirty threads may damage the assembly tool during compression.

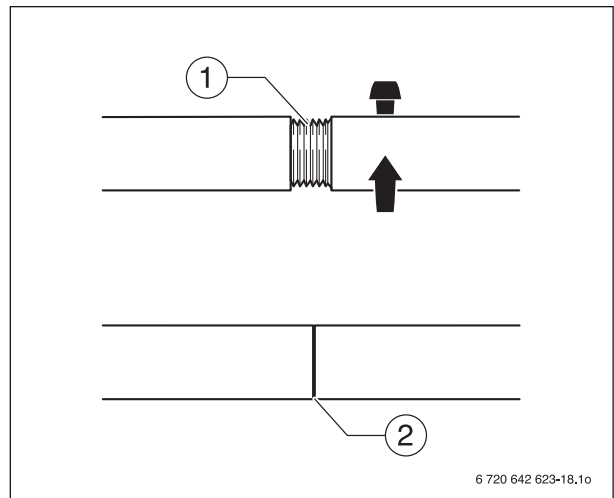

Fig. 16 Boiler assembly tool 2.3



CAUTION: Danger of accident from material fatigue. Improperly used or poorly maintained assembly tools may fail.

- ▶ Never work directly in front of the assembly tool while it is being tensioned.
- ▶ Ensure that no one is standing in front of the assembly tool.



NOTICE:

- ▶ Only boiler assembly tools size 2.3 may be used (Fig. 4, page 15 and Fig. 17, [1 and 2]).

7 Boiler block assembly

- ▶ Push the compression units (Fig. 17, [3 and 4]) onto the tie rods (Fig. 4, [4], page 15).
- ▶ Push a tie rod through the upper and lower hubs on the boiler.

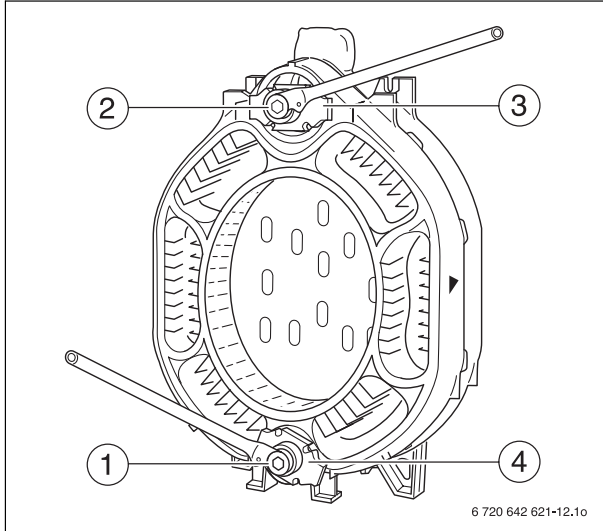

Fig. 17 Using the boiler assembly tool

- ▶ Push mating flanges (Fig. 18, [1]) onto the tie rods (Fig. 18, [3]) and secure each with wedge (Fig. 18, [2]).
- ▶ Hold the tie rod in the center of the boiler hubs and slightly draw together the assembly tools using the clamping nut.

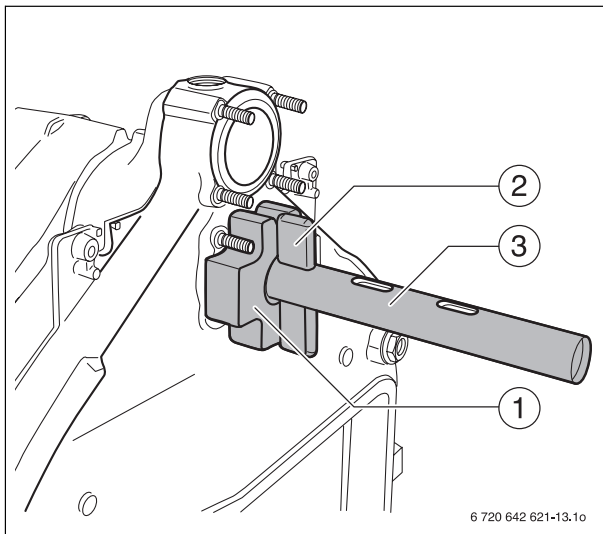

Fig. 18 Boiler assembly tool on rear section



NOTICE:

- ▶ Never compress more than one nipple connection (two sections) per pressing operation since otherwise the boiler block could compress unevenly. This causes leaks in the nipple connections.

- ▶ Place both ratchet wrenches onto clamping nuts of the compression unit and press boiler sections together by tightening evenly.



NOTICE:

- ▶ If the boiler packing grooves hit each other, immediately stop any compression. Additional compression could damage the boiler sections.

- ▶ Release and remove the boiler assembly tool.
- ▶ Check nipples are seated correctly.
- ▶ The boiler sections must be aligned to make the installation easier.
- ▶ Assemble all other boiler sections as described. The front section is always fitted last.
- ▶ After the front section is attached, loosen – the assembly tool but do not remove it.
- ▶ Insert the tie rod before removing the assembly tool!
- ▶ Insert the three tie rods (with spring packs fitted) into the cast lugs at the designated positions (Fig. 19 [1, 2, and 3]). When inserting the tie rods, make sure the spring packs are mounted on the rear of the boiler.
- ▶ Put a nut onto each of the threaded tie rods and tighten by hand.



NOTICE: Damage to system through excessively low contact pressure.

- ▶ Do not compress the spring pack. Only use the spring pack in its original state.

- ▶ Now tighten the nuts on the tie rods 1 to 1½ turns.
- ▶ Level the boiler block vertically and horizontally on the base/foundation (→ Chapter 6.3, page 17).
- ▶ Remove boiler assembly tool.

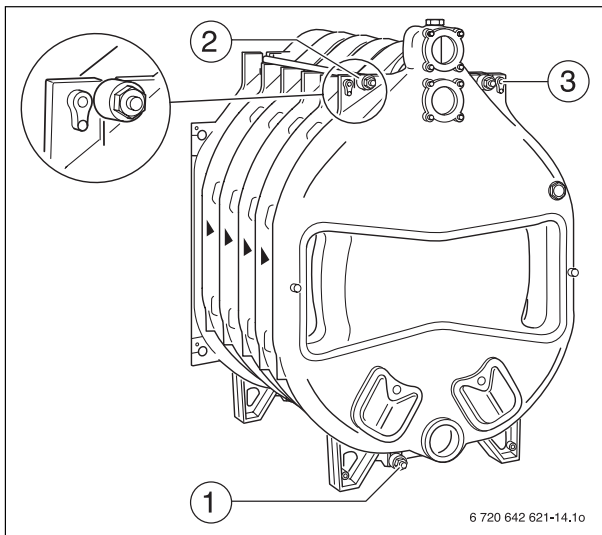

Fig. 19 Fitting the tie rods

- The next step describes the installation of the supply pipe (→ Chapter 7.4, page 24).

7.3 Setting up the boiler block (assembled block)



DANGER: Risk of fatal injury from falling objects.

- Provide a suitable means of supporting the load.
 - Observe all locally applicable occupational health & safety regulations regarding lifting equipment.
- Cut the retaining band (Fig. 20, [1]).
 - Remove the pallet prior to positioning the boiler block (Fig. 20, [2]).

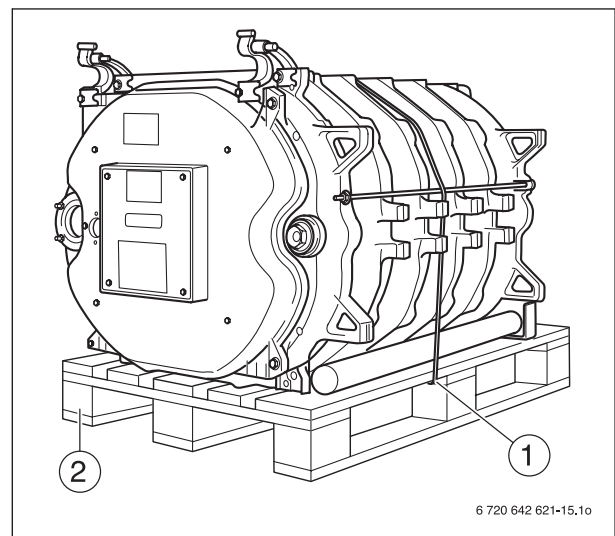

Fig. 20 Boiler block on pallet

- Level the boiler block vertically and horizontally on the base/foundation (→ Chapter 6.3, page 17).

The following pages describe the installation of the supply pipe and sensor well. You must do both irrespective of whether the boiler is supplied pre-assembled or in separate sections.

7.4 Sliding the supply pipe into place

- ▶ Push the flat gasket (Fig. 21, [1]) over the supply pipe (Fig. 21, [4]).
- ▶ Push the supply pipe from the front into the top boiler hub.
- ▶ Close off with flange cover (Fig. 21, [2]).



The supply pipe must be fixed in such a way that the holes on the supply pipe are positioned at the correct angle. This ensures optimum distribution of water in the area of the top boiler hub.

- ▶ Make sure that the cam [3] on the end plate of the supply pipe (→ Fig. 21, [3]) fits in the notch in the top boiler hub (→ Fig. 21, [5]) (Thermostream principle).

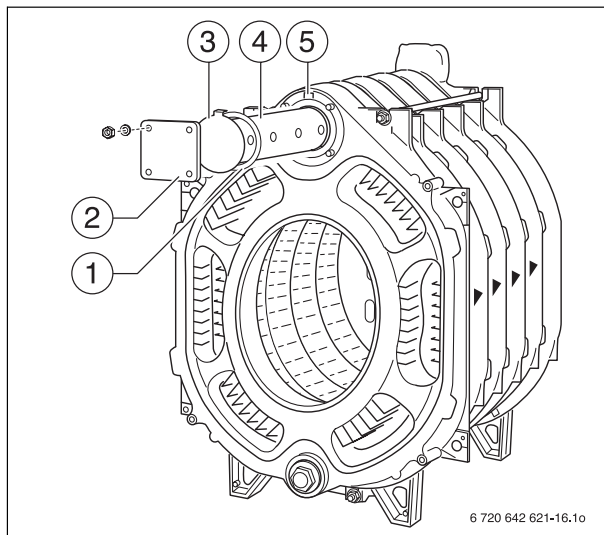

Fig. 21 Installing the supply pipe

7.5 Sealing the immersion sleeve

- ▶ Seal sensor well R $\frac{3}{4}$ (length: 110 mm) (Fig. 22, [1]) from the top into the R $\frac{3}{4}$ tapped hole in the supply connection (Fig. 22, [2]).

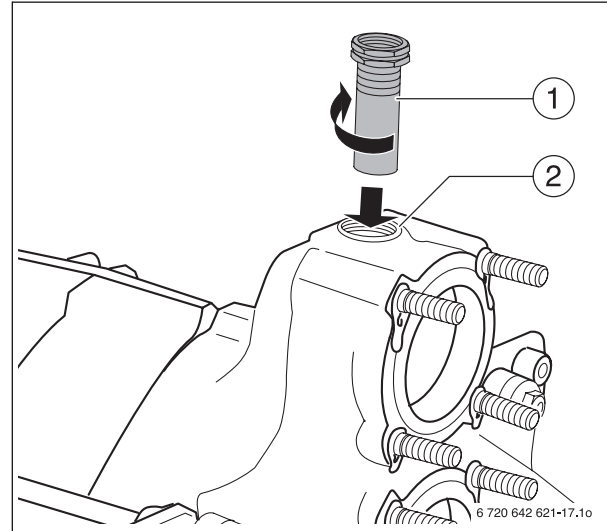

Fig. 22 Fitting the sensor well

7.6 Leak test

Perform a leak test of the boiler block only when the boiler was delivered disassembled. Pre-assembled blocks are leak tested at the factory.

For details of assembling the remainder of the boiler if the block is delivered pre-assembled, see → Chapter 10, page 36.

7.6.1 Carrying out leak test



NOTICE: Risk of system damage from overpressure.

- ▶ Ensure that no pressure, control or safety equipment is fitted during leak tests.

The testing pressure is based on the normal operating pressure of the heating system and should be 1.3 times that pressure, and in any case no less than 58 psi (4 bar).

Use a pressure gauge class 1.0 to measure the pressure.

- ▶ Close off lower boiler hub (Fig. 23, [3]) at the front and rear. To do this, place corresponding seal (Fig. 23, [1]) on the relevant boiler hub and seal-in the relevant sealing plug. In this case, the sealing plug with the R $\frac{3}{4}$ tapped hole for the fill and drain connection (Fig. 23, [2]) is mounted on the rear of the boiler.
- ▶ Install the on-site fill and drain valve.
- ▶ Close off supply and return connections (mount flange with purger on supply connection).

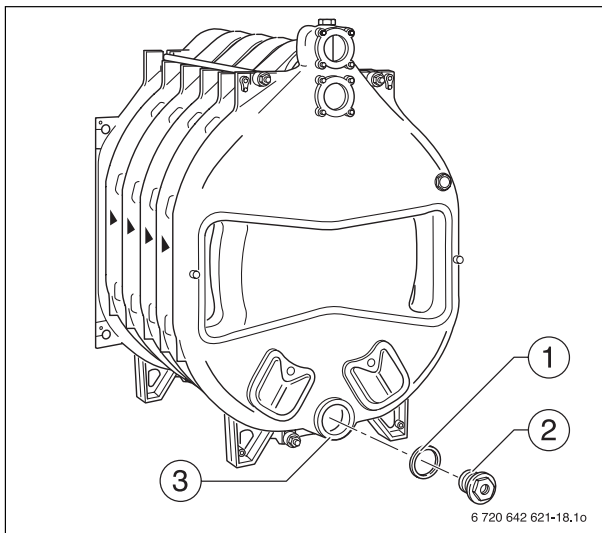

Fig. 23 Fitting the flange

- ▶ Slowly fill the boiler with water via the fill and drain connection. While doing this, purge the boiler via the boiler flow connection with purger.

7.6.2 Sealing leaks

- ▶ If a hub connection is leaking, first drain the water through the fill/drain valves.
- ▶ Remove supply pipe.
- ▶ Undo nuts on four tie rods and remove tie rods.
- ▶ Separate the boiler at the leak location by driving (ponding) in flat wedges or chisels between the sections at the designated points (Fig. 24, [1 and 2]) at the top and bottom.

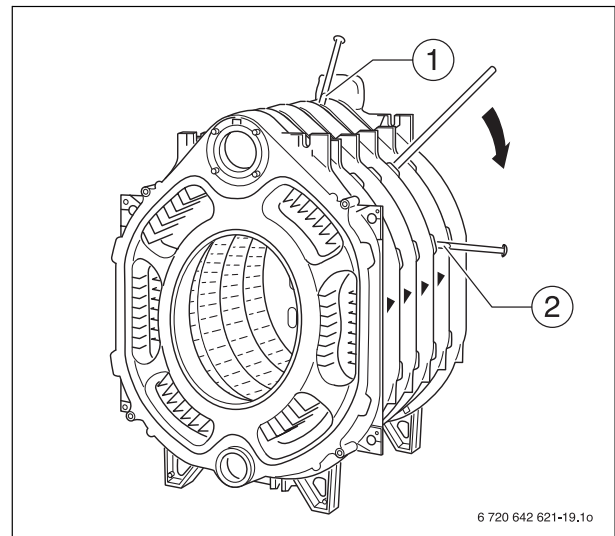

Fig. 24 Separating the boiler block



- ▶ Use new nipples and new sealant rope for the reassembly.
- ▶ Pull the boiler back together and repeat the leak test.

7.6.3 Supply flange with safety components, return flange

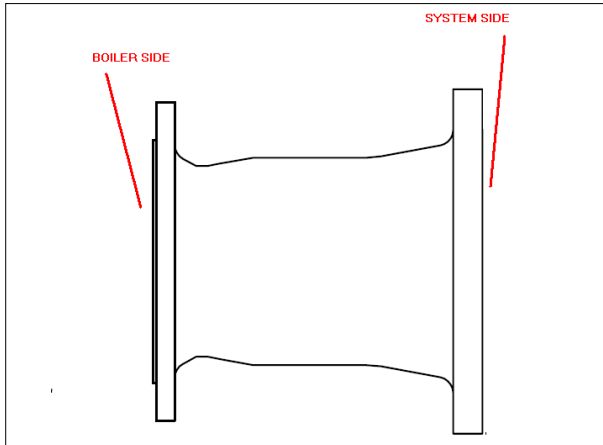

Fig. 25

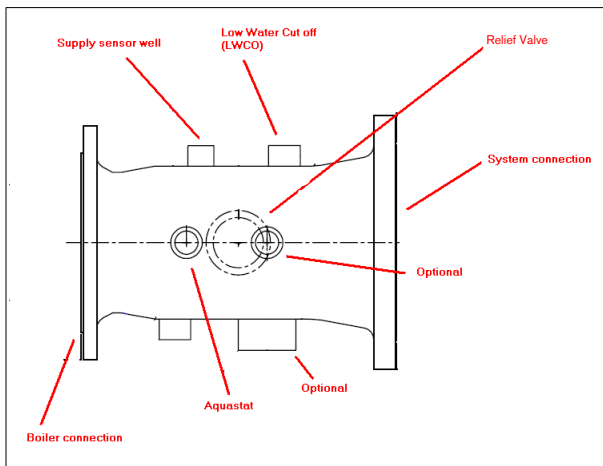

Fig. 26

7.7 Boiler water connections

Please observe the following information regarding the boiler connection to the system side. These instructions are important for trouble-free operation.



NOTICE: Risk of system damage from leaking connections.

- ▶ All pipe connections to the boiler must be free of stress and tension.



NOTICE: System damage from deposits, local overheating, and corrosion.

- ▶ As a basic rule, clean and flush existing systems before connecting the new boiler.
- ▶ Install a desludging unit in the boiler return to prevent damage to the boiler.

The weld neck flange is fitted to the upper boiler hub (Fig. 27, [6]) – return connection) if the return is connected at a later stage.

The weld neck flange and flat gasket are shown (Fig. 27, [4 and 5]).

- ▶ The supply connection flange (Fig. 27, [3]) with flat seal (Fig. 27, [2]) is required for connecting the supply at a later stage (Fig. 27, [1]).

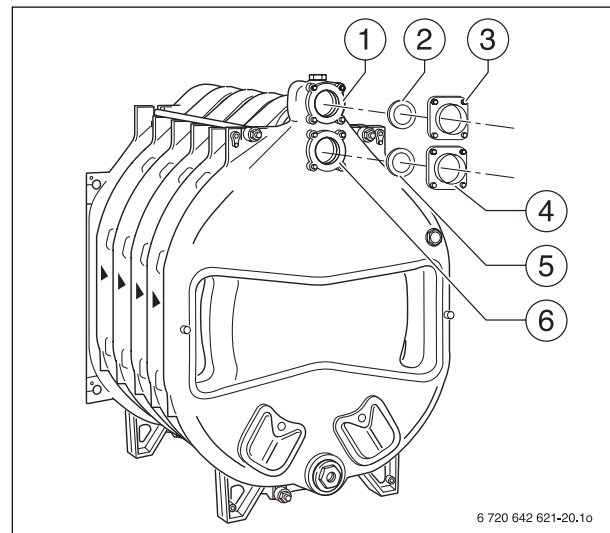

Fig. 27 Fitting a flange



The boiler supply and return manifolds are included in the Buderus scope of delivery.



NOTICE: Risk of system damage from temperature stresses.

- ▶ Install a fill valve on the system side.
- ▶ When the heating system is in operation, do not fill it via the boiler fill & drain valve. Instead, use the fill valve on the system side.

7.8 Installing fittings and burner door

Next step in the assembly process is to install the burner door and draft diverter. The pre-assembled boiler comes with these components already installed.

7.8.1 Positioning the draft diverter

KM ropes (Fig. 28, [1]) are used to seal the connections between the boiler and the draft diverter (Fig. 28, [2]).

- ▶ Coat the packing grooves with adhesive (primer).
- ▶ Push the KM ropes firmly into the groove. Insert the sealant rope in such a way that the joint is in the side part of the groove (Fig. 28, [3]).
- ▶ Place the draft diverter onto the two threaded studs on the rear section (Fig. 28, [4 and 5]) and secure using washers and nuts.

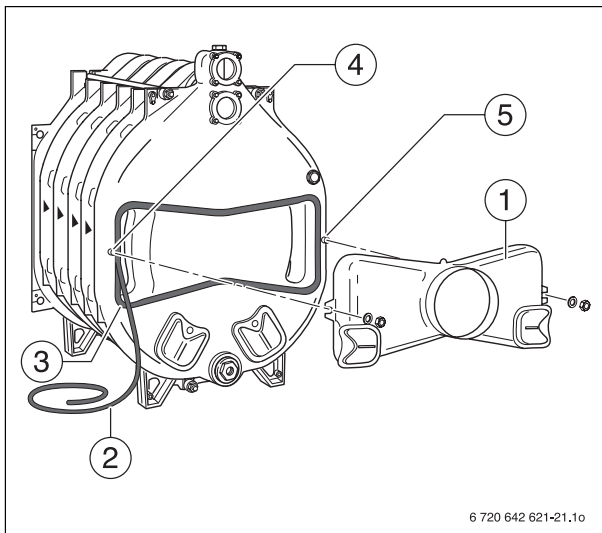

Fig. 28 Fitting the draft diverter

7.8.2 Screwing cleanout cover onto rear section

Fig. 29 shows the fully equipped rear section with the cleanout covers on the draft diverter (Fig. 29, 1 and 2) and the cleanout covers on the rear section (Fig. 29, [3 and 4]).

All cleanout covers are factory-fitted.

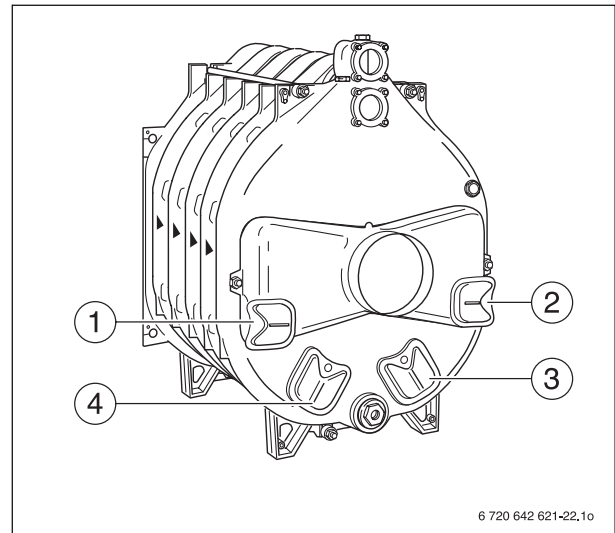

Fig. 29 Rear section with fittings installed

7.8.3 Inserting the flue gas baffle plates



In pre-assembled boilers, the flue gas baffles are already fitted

- ▶ Remove the cardboard transport protectors from the pre-assembled boiler.

- ▶ Take flue gas baffles from the crate and insert into the flue gas passages **as indicated by their inscription** (→ Fig. 30 and Tab. 10).

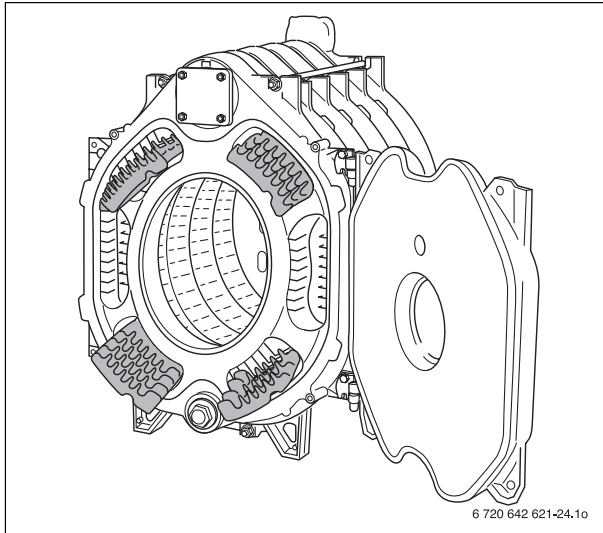

Fig. 30 Flue gas baffle plates

Number of boiler sections	Number of flue gas baffle plates	Length of flue gas baffle plate in inches (mm)	Installation directions on the flue gas baffle plate (→ Fig. 30)
5	4	14-11/64 (360)	top right top left bottom right bottom left
6 – 7	4	17-21/64 (440)	
8	4	14-11/64 (360)	
9	4	7-7/8 (200)	

Tab. 10

7.8.4 Fitting burner door panel

In the factory, the burner door is mounted with the hinges on the right hand side (Fig. 31, [4 and 6]). For left-hand closing, remove the hinges accordingly on the left-hand side of the burner door.

- ▶ Screw the hinge pins (Fig. 31, [1 and 3]) to the front boiler section with 2 M 12 x 50 machine screws in each case. This is shown in Fig. 31 for the right-hand closing version. For left-hand closing, secure hinge pins accordingly on the left-hand side.
- ▶ Affix Ø 18 mm diameter GP cord in the front section using adhesive. The sealant rope joint should be located at the side (Fig. 31, [2]).
- ▶ Hook the burner door with the hinge lobes into the hinge pins.

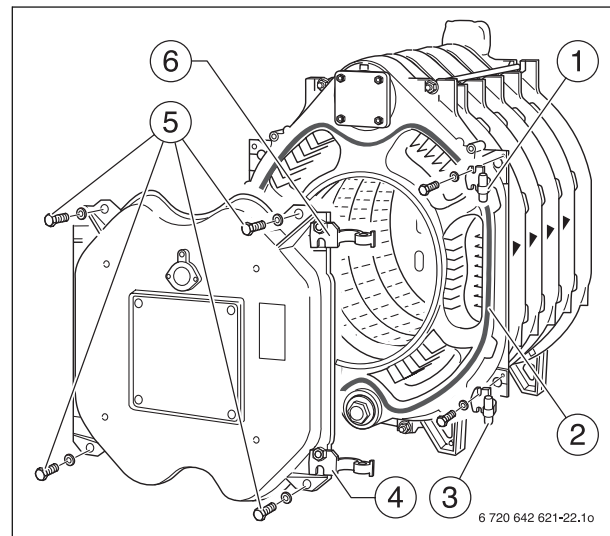

Fig. 31 Hooking in the burner door

7.9 Boiler outer casing

This section describes how to install thermal insulation and cladding components.

7.9.1 Fitting the profile rails

The folded edges of the front profile rails must face forwards.

- ▶ An additional nut must be turned on each of the two upper tie rods on the front of the boiler (Fig. 32, [2]).
- ▶ Insert the top front crosswise tie bar (Fig. 32, [1]) between the first and second nut of the tie rods in each case and fasten to the cast lugs.
- ▶ Fully tighten the outside nuts.
- ▶ Screw the bottom front crosswise tie bar (Fig. 32, [3]) with two machine screws to the feet of the boiler front section.

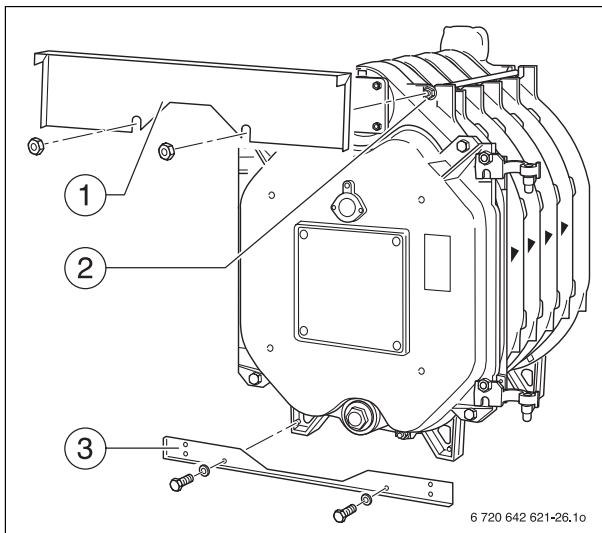

Fig. 32 Fitting the front profile rails

- ▶ Fasten top rear crosswise tie bar (Fig. 33, [1]) to the cast lugs then to rear section with machine screws (M 8 x 15). The folded edge of the upper crosswise tie bar must point **towards the front**.

- ▶ Screw the bottom crosswise tie bar (Fig. 33, [2]) to the feet of the rear section with two machine screws (M 8 x 15). The folded edge of the bottom crosswise tie bar must point towards the back.

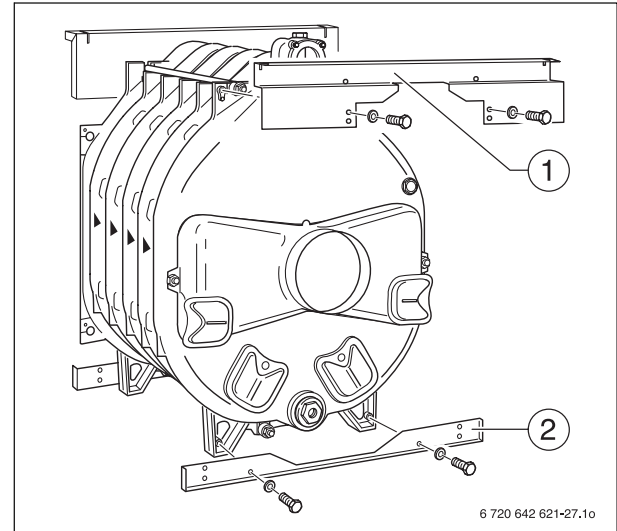

Fig. 33 Fitting the back profile rails

7.9.2 Attaching the thermal insulation

- ▶ The thermal insulation provided corresponds to the boiler size (Tab. 11). The thermal insulation must be arranged on the boiler block as shown in Fig. 34.
- ▶ Push the thermal insulation under the boiler block in the lower section of the boiler. The boiler feet are placed in the cut-outs in the thermal insulation.

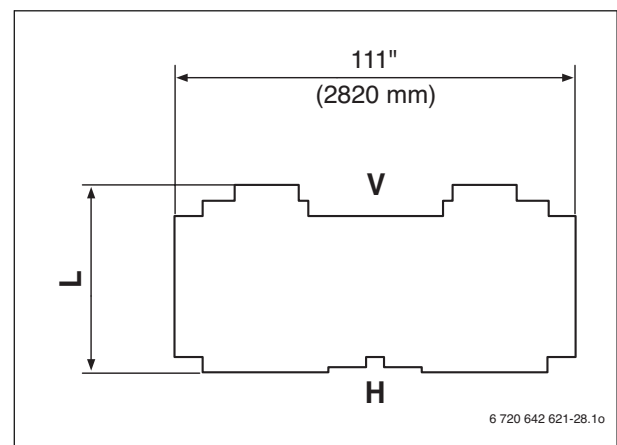

Fig. 34 Thermal insulation

- H** Rear (boiler back)
- V** Front (boiler front)

Boiler capacity	Boiler sections	L [inch] ([mm])
105	5	33" (840)
140	6	39-3/8" (1000)
170	7	45-11/16" (1160)
200	8	52" (1320)
230	9	58-1/4" (1480)

Tab. 11 Dimensions – thermal insulation

- ▶ Push rear section thermal insulation (Fig. 35, [2]) onto the flue outlet. The cut-out for the boiler flow and boiler return must point upwards.
- ▶ Hook the rear section thermal insulation to the top rear crosswise tie bar with two spring hooks (Fig. 35, [1]).
- ▶ Close the slot below the flue outlet with spring hooks (Fig. 35, [3]).

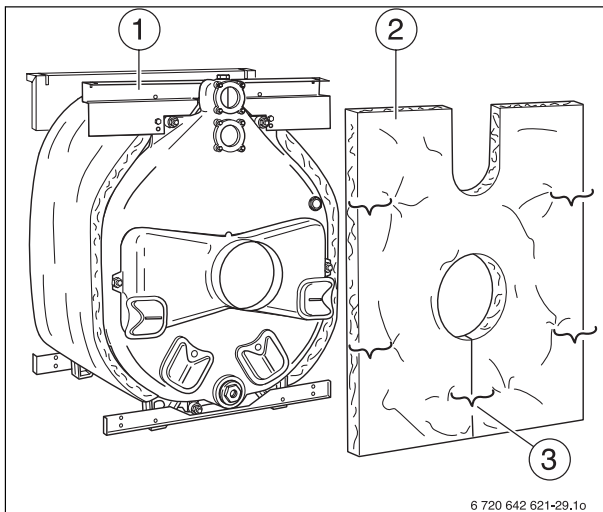

Fig. 35 Fitting the rear section thermal insulation

- ▶ Push the front thermal insulation (Fig. 36, [1]) with slots (Fig. 36, [2]) onto the front folded edge of the top crosswise tie bar.

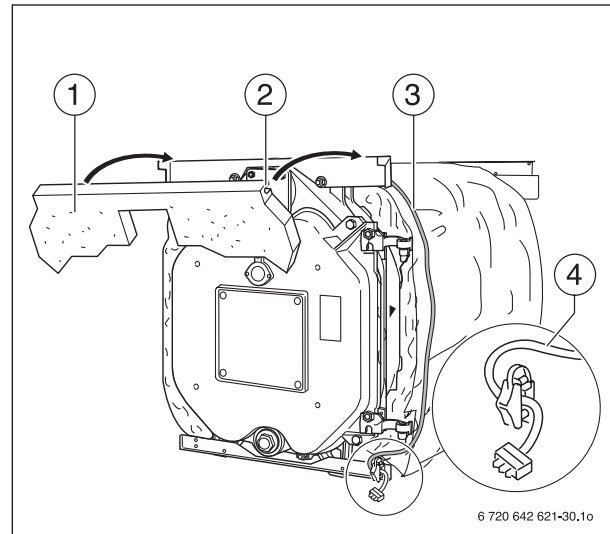

Fig. 36 Fitting the front thermal insulation

7.9.3 Fitting side panels and top covers

- ▶ Attach side panel (Fig. 37, [1]) with the cut-outs into the slots of the top connection plates (Fig. 37, [2]) and push forwards as far as it will go.
- ▶ Screw the side panels at the bottom to the bottom profile rails using two self-tapping screws in each case (Fig. 37, [3]).

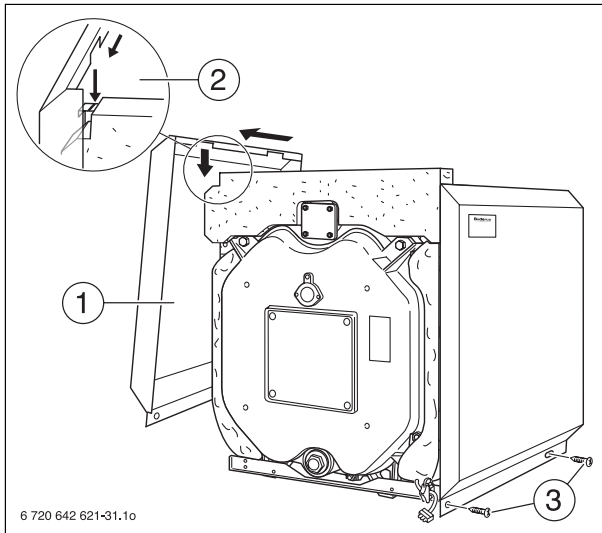

Fig. 37 Fitting the side panels

- ▶ Place front cover (Fig. 38, [1]) between the side panels so the cut-out (Fig. 38, [3]) fits over the tie bar.
- ▶ Screw the rear cover to the side panels using one self-tapping screw per panel (Fig. 38, [2]).

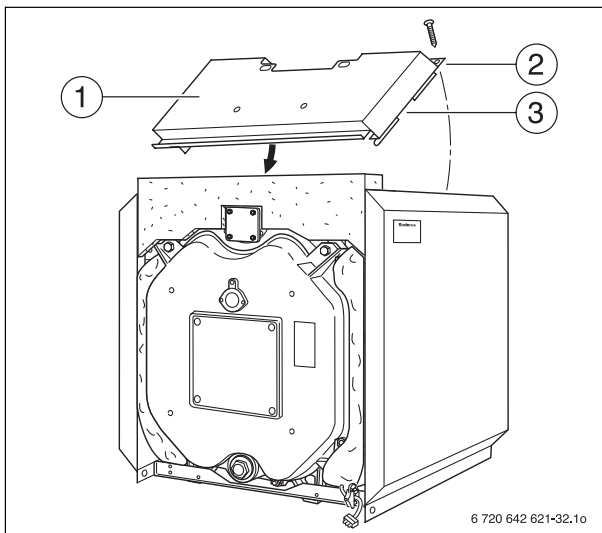

Fig. 38 Fitting the front cover

i Before fitting the other parts of the cover, you must first install the control panel, route the capillary tubes to the sensor well and insert the sensor into the sensor well (→ Chapter 9, page 34).

- ▶ Place rear cover (Fig. 39, [1]) between the side panels so the cut-out (Fig. 39, [2]) fits over the tie bar.

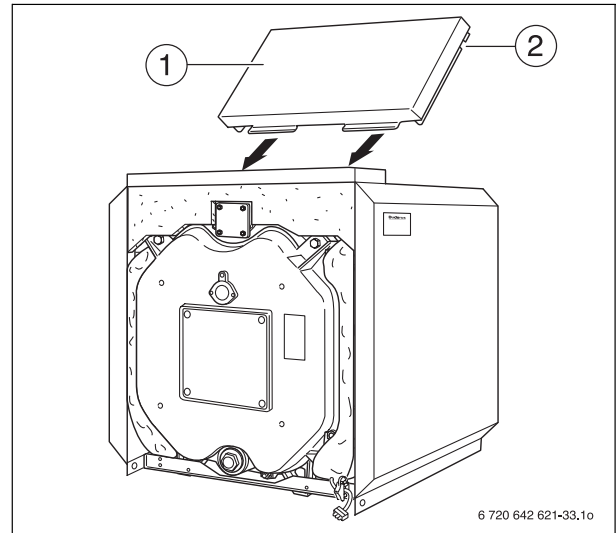

Fig. 39 Fitting the rear cover

Push the base rails (Fig. 40, [2]) onto the bottom folded edges of the side panels and screw on at the side using one self-tapping screw in each case (Fig. 40, [1 and 3]).

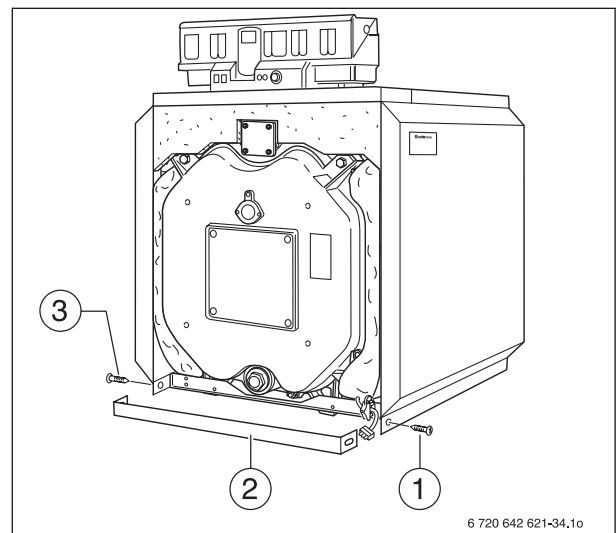

Fig. 40 Fitting the front base rail

7 Boiler block assembly

- ▶ Screw the top rear boiler panel (Fig. 41, [2]) to the back of the cover (Fig. 41, [1]) and the side panels.

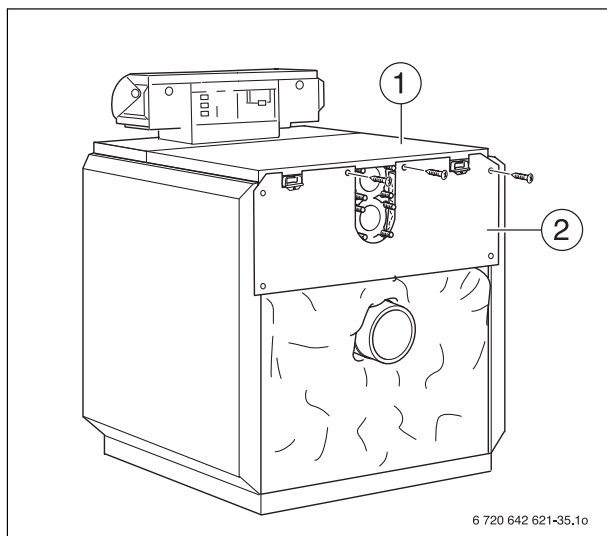

Fig. 41 Fitting the rear boiler panel

- ▶ Screw the bottom rear boiler panel (Fig. 42, [2]) with the cut-out for the fill and drain connection down onto the side panels (Fig. 42, [1 and 3]).

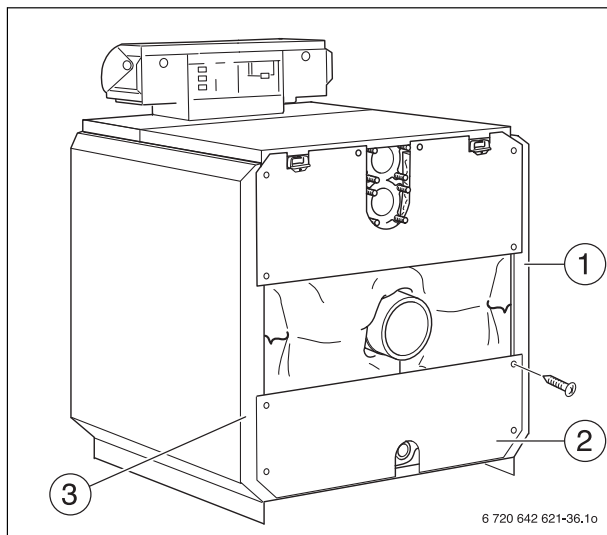

Fig. 42 Fitting the bottom rear boiler panel

- ▶ Attach the front panel (Fig. 43, [3]) at the bottom in the center to the base panel (Fig. 43, [2]).
- ▶ Attach the front panel at the top to the folded edge of the front cover (Fig. 43, [1]).

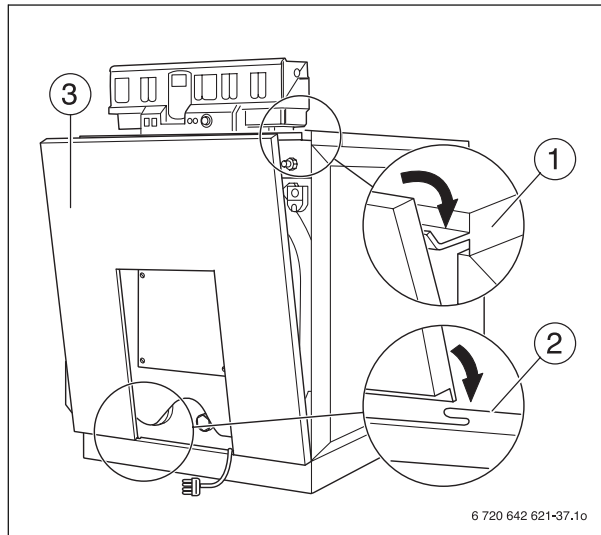

Fig. 43 Fitting the front panel

- ▶ Hook burner door panel into the cut-outs in the front cover (Fig. 44, [3]).

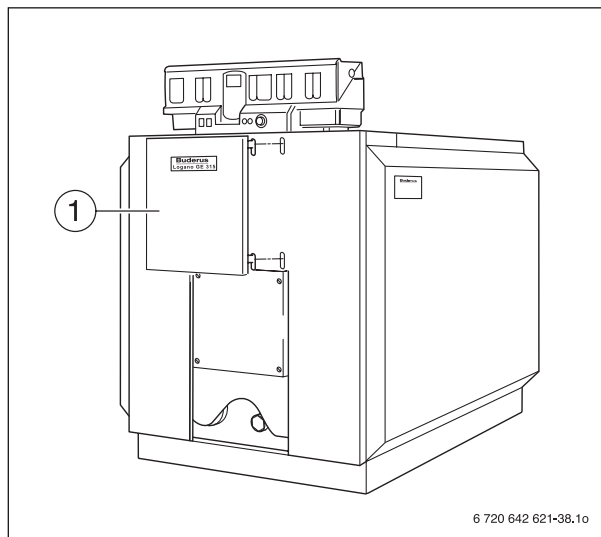

Fig. 44 Attaching the burner door panel

8 Connecting the boiler on the flue gas side

This chapter explains how to connect the boiler on the flue gas side.

8.1 Installing a vent pipe sealing collar (accessory)



We recommend you use a vent pipe sealing collar (→ Fig. 45, [1]).

- ▶ Push the vent pipe as far as possible onto the draft diverter outlet.
- ▶ Place the vent pipe sealing collar around the vent pipe and draft diverter outlet so that it overlaps at the top.
- ▶ Place hose clamps (Fig. 45, [4]) over the vent pipe sealing collar. One of the hose clamps must press onto the draft diverter outlet and one onto the vent pipe.
- ▶ Tighten hose clamps.

The vent pipe sealing collar must fit smoothly and firmly in place after tightening the hose clamps.



Retighten the hose clamps if required.

8.1.1 Installing a flue gas temperature sensor (accessory)

- ▶ Weld a sleeve (Fig. 45, [3]) at a distance of two (2) × vent pipe diameters (A) – min. 720 mm – from the draft diverter in the vent pipe.
- ▶ Fit the flue gas temperature sensor (Fig. 45, [2]) as described in the separate installation manual.

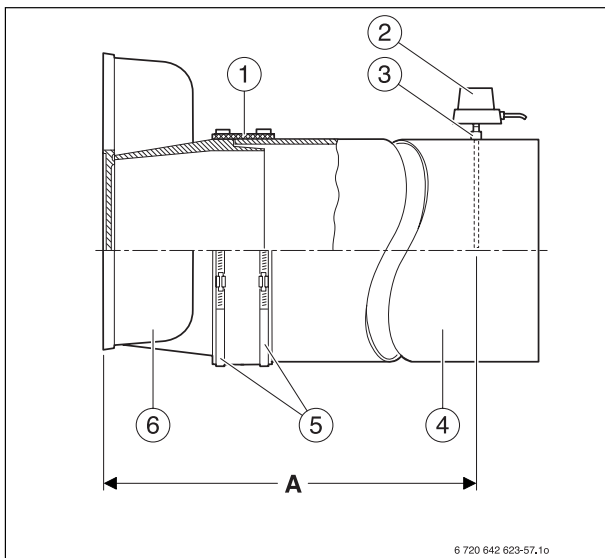

Fig. 45 Installing the vent pipe

- 1** Vent pipe sealing collar
- 2** Flue gas temperature sensor
- 3** Sleeve
- 4** Vent pipe
- 5** hose clamps
- 6** Exhaust Manifold
- A** 2 × Vent pipe diameter, at least 28 22/64 inches (720 mm)

9 Installing the control panel

9.1 Installing the control panel

Fig. 46 shows the control panel and the front top cover from behind.

- ▶ Undo both screws in the terminal cover (Fig. 46, [1]). Lift the terminal cover up and off.
- ▶ Put the control panel in place. Fit the control panel at the front by inserting the alignment tabs (Fig. 46, [4]) into the oval holes in the front top boiler cover (Fig. 46, [5]). Pull the control panel forwards and then tip backwards. The flexible hooks (Fig. 46, [2]) must engage with the rectangular cutouts in the rear of the front boiler cover (Fig. 46, [3]).
- ▶ Screw the base of the control panel on the left and right of the cable duct (Fig. 46, [6]) on the front boiler cover using two self-tapping screws (Fig. 46, [7]).

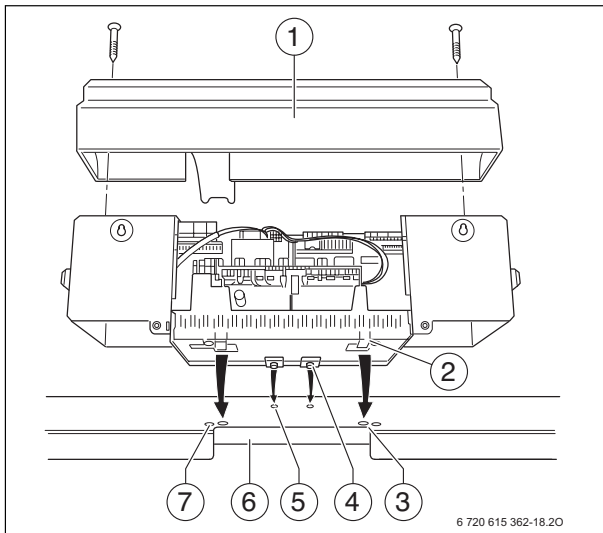

Fig. 46 Installing the control panel

9.2 Fitting temperature sensor assembly



Observe the following when connecting the control panel:

- ▶ Lay out cables and capillaries carefully.
 - ▶ Do not bend the capillaries during installation.
 - ▶ Never carry out any electrical work on the heating system unless you are licensed for this type of work. If you are not suitably qualified, arrange for a qualified electrician to make the electrical connections.
 - ▶ Observe the local regulations!
-
- ▶ If necessary, make knock-outs (Fig. 47, [1]) in the rear panel of the cable entry (Logamatic 33..) or remove the rear panel section (Logamatic 43..) (Fig. 47, [2]).
 - ▶ Route the capillary tubes through the cable entry and unroll to the required length.

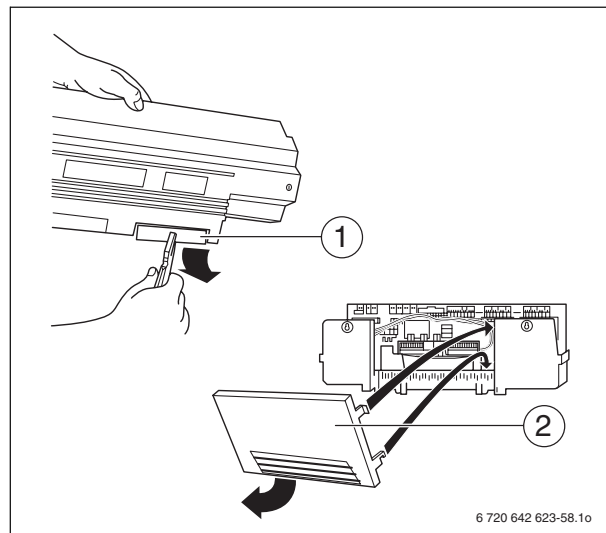

Fig. 47 Preparing the cable entry

The sensor well has already been sealed in the flow connection socket (→ Chapter 7.5, page 24).

The temperature sensor set connected to the control panel (consisting of three temperature sensors and one sensor blind piece → Fig. 48, [1]) is installed in the sensor well R³/₄ ".

- ▶ Route capillary pipe sensor to the measuring port of the boiler and then guide the sensor into the sensor well (Fig. 48, [2]) and secure with the retaining clip (Fig. 48, [3]).

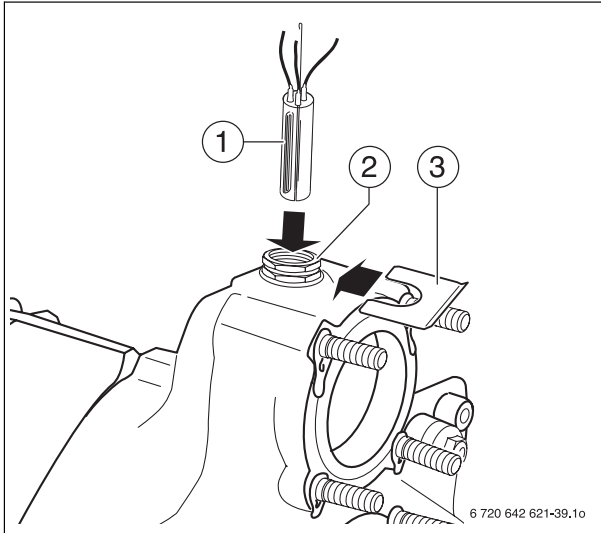

Fig. 48 Fitting the sensor set

- ▶ Screw cable entry (Fig. 49, [1 and 2]) to the left and right of the rear boiler panel.

A permanent connection must be made in accordance with EN 50165 or the relevant national installation standard.

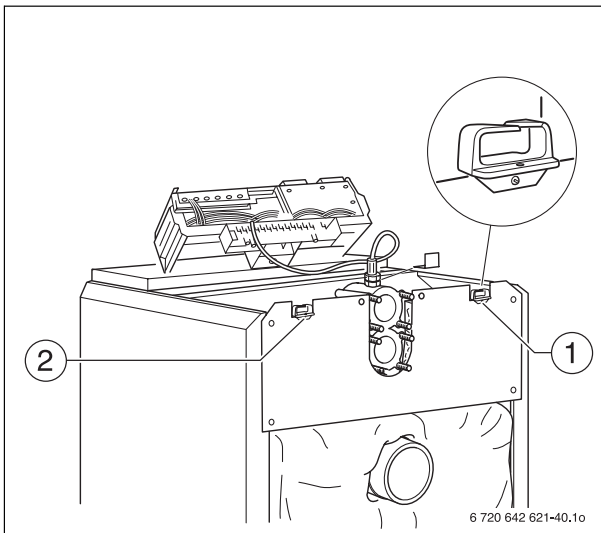

Fig. 49 Making the electrical connections

- ▶ Wire up the electrical connections as shown in the wiring diagram. Take care to ensure correct cable and capillary tube routing.



Secure all cables with cable clips.

- ▶ Insert cable clips with cable inside into the clip frame and secure by clamping it with the lever (Fig. 50, [1]).

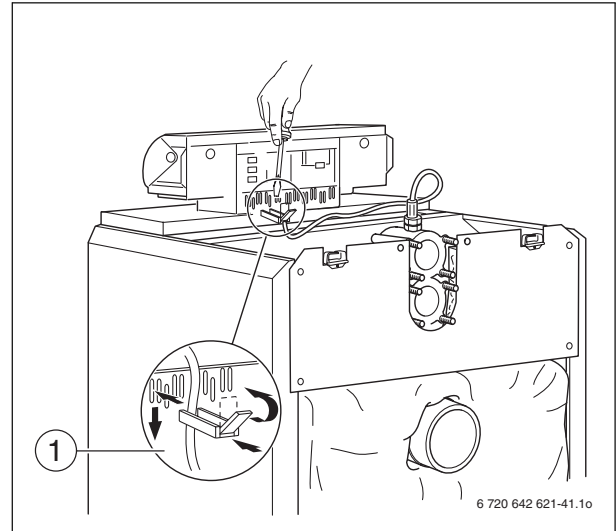

Fig. 50 Fastening the electr. connecting leads

- ▶ Hook the lower hook on the rear panel section (Logamatic 43..) into the clip frame and apply pressure at the top until the side hooks click into place (Fig. 47, [2]).
- ▶ Screw terminal cover (Fig. 46, [1]) with the two self-tapping screws back into the control panel base (Fig. 51).

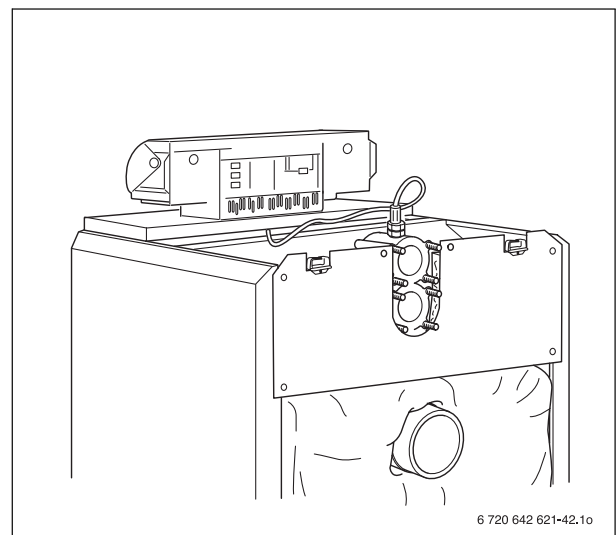

Fig. 51 Boiler with fitted control panel

10 Mounting the burner

This chapter explains the basic steps involved in fitting a burner.



NOTICE: Risk of system damage from use of incorrect burner.

- ▶ Only use burners that meet the technical requirements of the oil/gas-fired boiler Logano G315 (→ chapter 3, page 11).

- ▶ Close the burner door and seal with 4 machine screws (M16 × 140) (→ Chapter 7.8.4, page 28, Fig. 31, [5]). Tighten the machine screws evenly crosswise.



You can obtain undrilled or predrilled burner plates (hole pattern depends on burner) as accessories from Buderus.

If you have ordered an undrilled burner plate, you will have to machine this on site:

- ▶ Drill or cut the burner plate (→ Fig. 52, [1]) to match the required burner tube diameter $\varnothing 10 \frac{5}{8}$ inches (270 mm).
- ▶ Drill holes for fastening the boiler using the burner connecting flange as a template.
- ▶ Screw burner plate onto the burner door (seal with GP sealant rope; diameter $\varnothing 25/64$ inches (10 mm)).
- ▶ Screw the burner to the burner plate.
- ▶ Cut out insulating rings to match the burner tube diameter (→ Fig. 52, [2]).
- ▶ Fill the remaining gap between the burner door thermal insulation and the burner tube (→ Fig. 52, [4]) using the appropriate insulating rings (→ Fig. 52, [3]).
- ▶ Connect the vent connection to the burner to ensure the inspection window remains free of deposits.

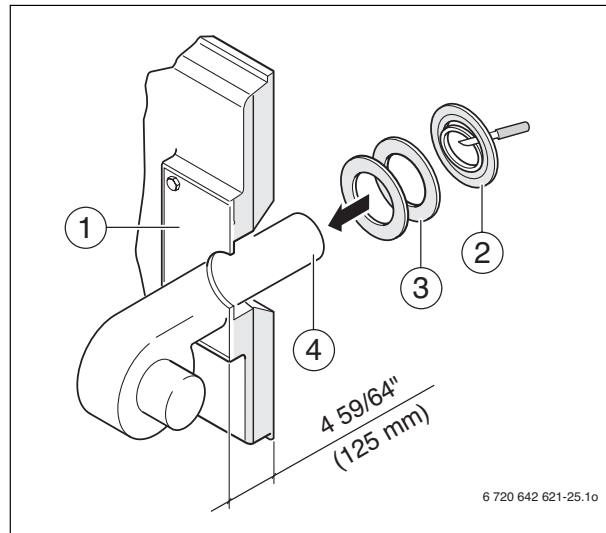

Fig. 52 Mounting the burner

11 System start-up

You can connect control panels of the 4000 series to the Logano G315. The commissioning process for the different types of control panel is the same.



NOTICE: The boiler can be damaged through heavy dust deposits!

- ▶ Do not operate the boiler where heavy dust contamination persists, e.g. through building work inside the boiler room.

- ▶ Complete the commissioning log (→ Chapter 11.6, page 39).

11.1 Filling the system



NOTICE: Risk of system damage from temperature stresses.

- ▶ During operation, only fill the heating system via the fill valve on the system side.

Refer to the table below for information about correct use and treatment of the fill and make-up water.

The pH value of the boiler water increases after the heating system has been filled. After 3 – 6 months (at the time of the first service), check whether the pH value of the boiler water has stabilized.

Overall boiler output MBH (kW)	Ca (HCO ₃) ₂ concentration / grains per gallon ¹⁾ ppm	Maximum fill and make-up water quantity V _{max} / ft ³ (m ³)	Boiler water pH value
341 < Q ≤ 1,194 (100 < Q ≤ 350)	≤ 11.7 (≤ 2.0)	V _{max} = three times system volume	8.2–9.5
1,194 < Q ≤ 3412 (350 < Q ≤ 1000)	≤ 8.8 (≤ 1.5)		
341 < Q ≤ 1,194 (100 < Q ≤ 350)	> 11.7 (> 2.0)	$V_{\max} = 0,0243 \times \frac{Q \text{ (MBH)}}{\text{Ca(HCO}_3)_2 \left(\frac{\text{gr}}{\text{gal}}\right)}$ $\left(V_{\max} = 0,0313 \times \frac{Q \text{ (kW)}}{\text{Ca(HCO}_3)_2 \left(\frac{\text{mol}}{\text{m}^3}\right)} \right)$	8.2–9.5
1,194 < Q ≤ 3412 (350 < Q ≤ 1000)	> 8.8 (> 1.5)		

Tab. 12 Requirements for fill, make-up and boiler water

1) 1 ft³ = 7.48 gal

11.2 Commissioning the system

Observe the following when commissioning:

- ▶ Purge your heating system via its radiators prior to commissioning.
- ▶ Check that the hot gas baffle plates are inserted correctly (→ Chapter 7.8.3, page 28).

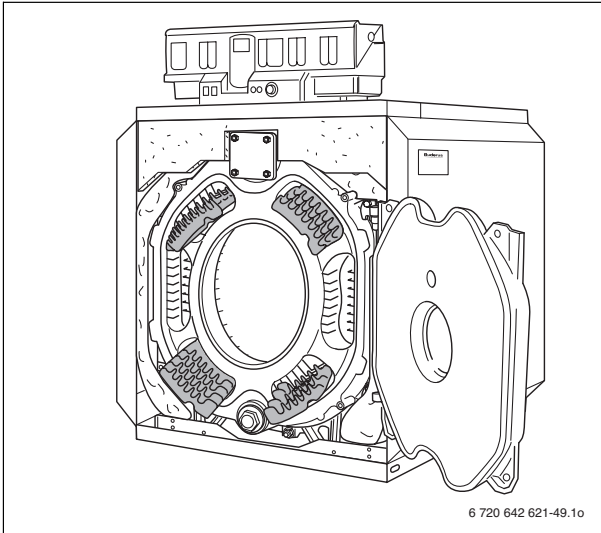

Fig. 53 Check position of flue gas baffles

11.3 Start up the control panel

Please see the accompanying technical documentation for the 4000 series control panel you are using for information on how to start it up.

11.4 Initial burner start-up

- ▶ When commissioning the burner, follow the installation and maintenance instructions enclosed with the burner.
- ▶ Fill out the commissioning log in the burner documentation.

If you notice when taking measurements for the commissioning log that the flue gas temperature is too low for the vent pipe (risk of condensation), you can raise the flue gas temperature (→ Chapter 11.5, page 38).

11.5 Raising flue gas temperature

With a new boiler, the flue gas temperature when the boiler temperature is 176 °F (80 °C) will be around 320 – 356 °F (160 – 180 °C), depending on the boiler rating.

In two-stage operation the temperature of the flue gas is lower.

You can increase the flue gas temperature further by removing individual hot gas check plates and hot gas baffle plates or combinations of these.



You should only consider modifying the hot gas check plates as a last resort as once you have reduced the size of the hot gas check plates you cannot change this back.

- ▶ Take the boiler out of operation in accordance with the operating instructions.

You can increase the temperature of the flue gas by carrying out the following measures.

Removing flue gas baffles

For boilers with 7 – 11 boiler sections (819 – 1,553 MBH or 240 – 455 kW) an increase of the flue gas temperature can be achieved through **pair-wise** removal of the upper or lower flue gas baffles.

11.6 Commissioning log

The Logano G315 can be used with an oil- or gas-fired burner. Fill in the commissioning log for the appropriate type of oil or gas burner carefully.

- ▶ Sign all start-up work as completed and enter the relevant date.

Commissioning operations		Individual steps	Comments (signature)
1.	Perform leak test of the entire system		
2.	Fill the heating system with water	→ page 37	
3.	Purge the heating system		
4.	Perform the leak test if the boiler was assembled on-site	→ page 25	
5.	Record the filling water quantity and composition in the operator's log (included with the technical documentation).		
6.	Check position of flue gas baffles	→ page 28	
7.	Check the fuel line for leaks		
8.	Start up the control panel	→ page 38	
9.	Initial burner start-up	See burner documentation	
10.	Check the flue gas temperature	→ page 38	
11.	Check vent pipe for leaks		
12.	Check the boiler on the hot gas side for leaks		
13.	Enter the fuel used in the table provided in the operating instructions		
14.	Inform the owner and operator and hand over technical documentation		
15.	Confirm properly-completed commissioning		
<hr style="width: 50%; margin-left: 0;"/> Company stamp/signature/date			

12 Shutting down the system

You can connect control panels of the 4000 series to the Logano G315. The shutting down process for the different types of control panel is the same.



NOTICE: Risk of system damage from freezing.

- ▶ The heating system can freeze up if it is disabled, e.g. shut down due to a fault.
- ▶ Protect the heating system from freezing when temperatures below freezing are expected. Drain the boiler water out of the heating system at its lowest point using the drain valve. To do this, open the purger at the highest point in the system.

12.1 Shutting down the heating system via the control panel

Shut down your boiler via the control panel. Shutting down the control panel automatically also switches off the burner.

- ▶ Isolate the fuel supply to the burner.

12.2 Shutting down the system in an emergency



Switch off the system via the boiler room fuse or heating system emergency shutoff switch only in emergencies.

In other dangerous situations, immediately close the main fuel shut-off valve and the power supply of the heating system via the boiler room main fuse or the heating system emergency shutoff switch.

- ▶ Shut the fuel supply to the burner.

13 System inspection and maintenance

13.1 General information

Offer your customer a maintenance contract covering annual inspection and servicing work as required. To find out what a contract for annual inspection and demand-based servicing covers, refer to Chapter 13.7, page 46.



DANGER: Risk of fatal injury from the explosion of flammable gases.

- ▶ Work on gas components must be carried out by trained and certified personnel only.

Cleaning and maintenance:

If heating oil is being used, cleaning and maintenance must be carried out twice a year. Depending on demand/run time, a shorter cleaning interval may be necessary.



Spare parts can be ordered from the Buderus spare parts catalog.

13.2 Why is regular maintenance important?

You should have your customer's system serviced for the following reasons:

- to achieve a high level of efficiency and to operate the system economically (low fuel consumption),
- to achieve a high level of operational reliability,
- to maintain a clean and environmentally-friendly combustion.

13.3 Cleaning the boiler with cleaning brushes

- ▶ Put the main power switch (→ Fig. 54, [1]) on the control panel in position "0".
- ▶ Isolate the fuel supply to the burner.
- ▶ De-energize the system.



DANGER: due to electricity.

- ▶ Before starting electrical work, isolate all poles of the system and secure against unintentional reconnection.

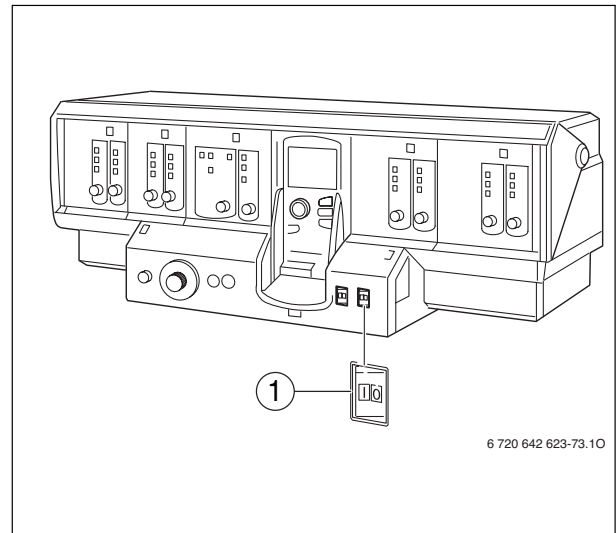

Fig. 54 Example showing Logamatic 4311

- ▶ Slightly lift the front panel and remove by pulling forwards (Fig. 55).
- ▶ Undo the four machine screws that fasten the burner door to the front section (→ Chapter Fitting burner door panel, page 28).

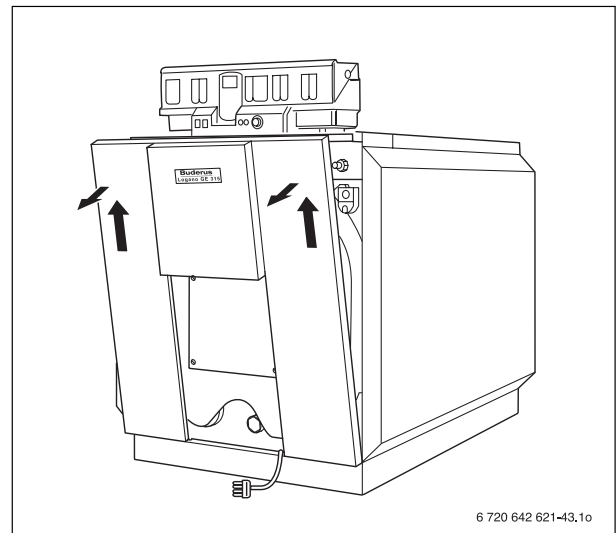

Fig. 55 Removing the front panel

- ▶ Swing out burner door.
- ▶ Take the flue gas baffle plates forwards out of the flue gas passages (Fig. 56, [1 – 4]).

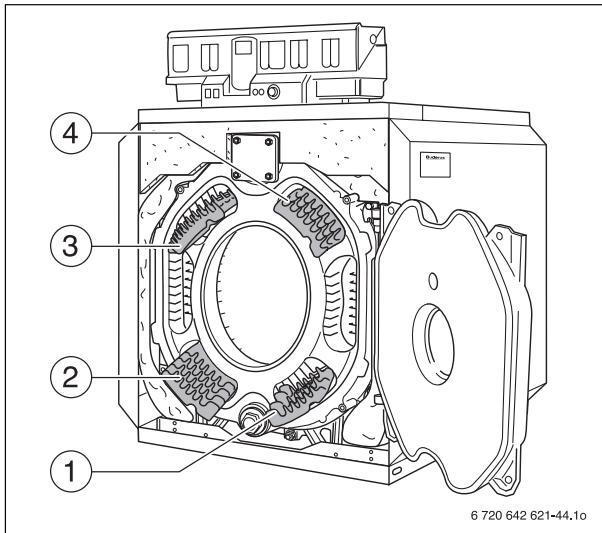

Fig. 56 Flue gas baffles, removing

The various brush types available from **Buderus** (optional extras) are shown in Fig. 57.

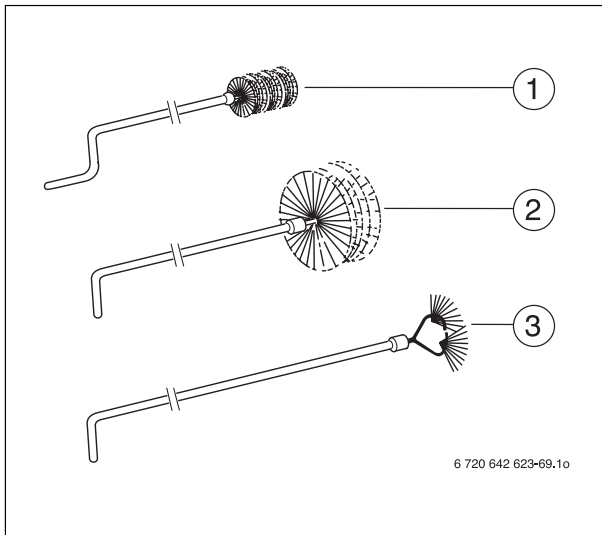

Fig. 57 Cleaning brushes

- ▶ Clean the flue gas passages (Fig. 58, [1]) starting at the front and working towards the back with cleaning brushes 1 and 2 (Fig. 57).
- ▶ Clean the rear wall of the combustion chamber with cleaning brush 3.
- ▶ Clean the rest of the combustion chamber (Fig. 58, [2]) with cleaning brush 2.
- ▶ Clean the bottom flue gas passages from the front with cleaning brush 2 (Fig. 58, [1]).

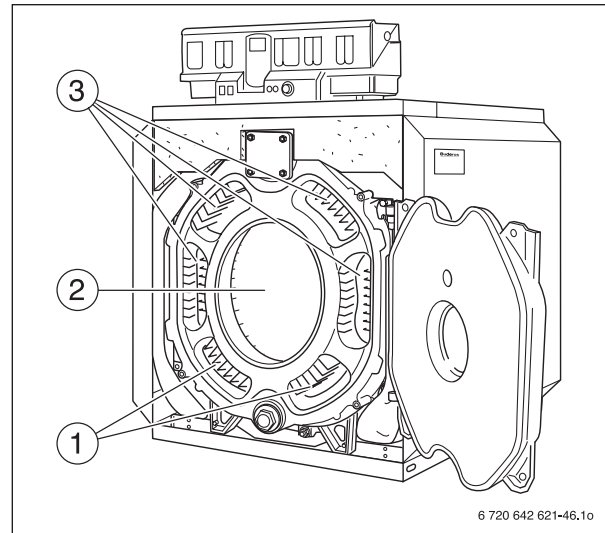

Fig. 58 Heat exchanger heater flue, cleaning

- ▶ Undo the four self-tapping screws on the rear boiler panel at the bottom.
- ▶ Remove bottom rear boiler panel.
- ▶ Loosen spring hooks below the flue outlet (→ Fig. 35, page 30).
- ▶ Fold both ends of the thermal insulation up (Fig. 59, [1]) and fasten in this position with the spring hooks.
- ▶ Remove the cleanout covers from the rear section (Fig. 59, [2]) and on the draft diverter (Fig. 59, [3]).
- ▶ Remove all loose combustion residues from the combustion chamber, the flue gas passages and the draft diverter.
- ▶ Check sealant ropes on the openings of the cleanout covers and burner door. Replace damaged or hardened sealant ropes.

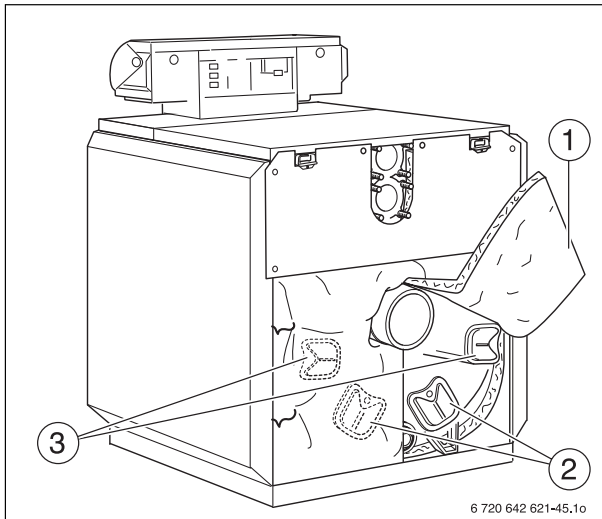

Fig. 59 Removing the cleanout cover



You can obtain sealant ropes from your nearest branch office.

- ▶ Clean flue gas baffle plates with the cleaning brushes.
- ▶ Insert the flue gas baffle plates in the flue gas passages (→ Chapter Inserting the flue gas baffle plates, page 28).
- ▶ Fasten cleanout cover and close burner door. Tighten screws evenly.
- ▶ Close the burner door and tighten the screws evenly.
- ▶ Fold the rear section thermal insulation down and pull together under the flue outlet using the spring hook (Fig. 60, [1]).

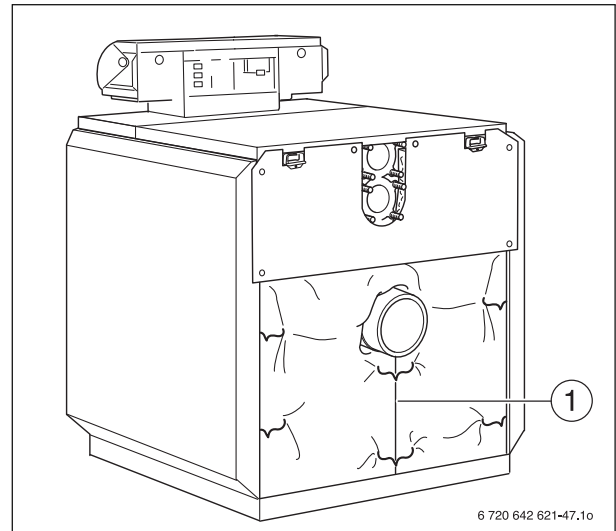

Fig. 60 Pulling the rear section thermal insulation together

- ▶ Hang the bottom rear boiler panel sections on the left and right into the slots in the folded edge of the upper rear boiler panel and the side panel and screw the connecting plate below the flue outlet onto the bottom boiler rear sections.

13.4 Wet-cleaning the boiler

When wet-cleaning, pick the cleaning agent based on the level of contamination.

Proceed with wet cleaning in the same order as described for cleaning with cleaning brushes (→ Chapter 13.3, page 41).



For wet-cleaning (chemical cleaning), observe the operating instructions of the relevant cleaning equipment and cleaning agent. It may be necessary to vary the wet-cleaning process from that described here.

- ▶ Select a cleaning agent that is appropriate for the type of contamination (soot or encrustation).
- ▶ Cover the control panel with foil to prevent penetration by the cleaning agent.
- ▶ Spray cleaning agent evenly from the top into the flue gas passages.
- ▶ Heat up the boiler to a boiler water temperature of at least 158 °F (70 °C).
- ▶ Brush out the heat exchanger heater.

13.5 Checking the operating pressure

The operating pressure must be at least 15 psi (1 bar).

- ▶ Read the current operating pressure (psi) and temperature °F (°C) from the temperature/pressure gauge.
- ▶ If the operating pressure drops below 15 psi (1 bar), refill boiler water.

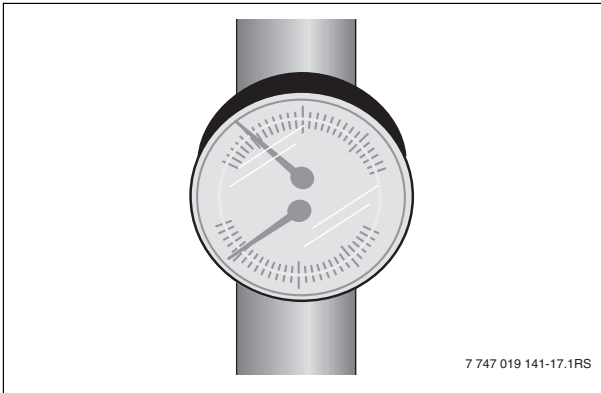

Fig. 61 Pressure/temperature gauge

13.6 Refilling with boiler water and purging the system



NOTICE: Risk of system damage from temperature stresses.

- ▶ When the heating system is in operation, do not fill it via the boiler fill & drain valve. Instead, use the fill valve on the system side.



Bring the system up to the required operating pressure.

- ▶ Slowly fill the heating system via the on-site fill valve. During filling, observe the display (pressure gauge).
- ▶ Once the desired operating pressure is reached, stop the procedure.
- ▶ Purge the heating system via the purge valves on the heating bodies.
- ▶ Refill with water again if the operating pressure drops as a result of purging the system.



NOTICE: Risk of system damage from frequent refilling.

- ▶ The system may be damaged, depending on water quality, by corrosion or scaling, if you frequently need to re-fill your system with make-up water.
- ▶ Ensure that your heating system is bled.
- ▶ Check the heating system for leaks and the function of the expansion vessel.

13.7 Inspection and maintenance reports

The inspection and maintenance logs provide an overview of the required inspection and maintenance work.

The inspection and maintenance logs can also be used as templates.

- ▶ Initial and date the inspection operations completed.

Inspection work		Page	Date: _____	Date: _____
1.	Check general condition of heating system		<input type="checkbox"/>	<input type="checkbox"/>
2.	Visual inspection and function check of the heating system		<input type="checkbox"/>	<input type="checkbox"/>
3.	Check fuel and water-carrying components of the system for: <ul style="list-style-type: none"> • Leaks during operation • Visible signs of corrosion • Signs of aging 		<input type="checkbox"/>	<input type="checkbox"/>
4.	Check the combustion chamber and heating surfaces for contamination. Shut down the heating system first.	→ 41	<input type="checkbox"/>	<input type="checkbox"/>
5.	Check the burner (→ burner documentation)		<input type="checkbox"/>	<input type="checkbox"/>
6.	Check the flue gas and venting system for proper operation and safety (→ burner documentation)		<input type="checkbox"/>	<input type="checkbox"/>
7.	Check the operating pressure and inlet pressure of the diaphragm expansion vessel for heating systems	→ 44	<input type="checkbox"/>	<input type="checkbox"/>
8.	Check the function of indirect-fired heater and rod (→ tank documentation)		<input type="checkbox"/>	<input type="checkbox"/>
9.	Check the control panel setting (→ control panel documentation)		<input type="checkbox"/>	<input type="checkbox"/>
10.	Record the final checks of the inspection work, incl. measurements and test results		<input type="checkbox"/>	<input type="checkbox"/>
	Confirm professional inspection		Company stamp/ signature	Company stamp/ signature



If during inspection work conditions are identified that require maintenance, this work must be performed on an as-required basis. If make-up water is added, the quality of this water must correspond to the specifications in the enclosed operating manual.

	Date: _____	Date: _____	Date: _____	Date: _____
1.	<input type="checkbox"/>	<input type="checkbox"/>	<input type="checkbox"/>	<input type="checkbox"/>
2.	<input type="checkbox"/>	<input type="checkbox"/>	<input type="checkbox"/>	<input type="checkbox"/>
3.	<input type="checkbox"/>	<input type="checkbox"/>	<input type="checkbox"/>	<input type="checkbox"/>
4.	<input type="checkbox"/>	<input type="checkbox"/>	<input type="checkbox"/>	<input type="checkbox"/>
5.	<input type="checkbox"/>	<input type="checkbox"/>	<input type="checkbox"/>	<input type="checkbox"/>
6.	<input type="checkbox"/>	<input type="checkbox"/>	<input type="checkbox"/>	<input type="checkbox"/>
7.	<input type="checkbox"/>	<input type="checkbox"/>	<input type="checkbox"/>	<input type="checkbox"/>
8.	<input type="checkbox"/>	<input type="checkbox"/>	<input type="checkbox"/>	<input type="checkbox"/>
9.	<input type="checkbox"/>	<input type="checkbox"/>	<input type="checkbox"/>	<input type="checkbox"/>
10.	<input type="checkbox"/>	<input type="checkbox"/>	<input type="checkbox"/>	<input type="checkbox"/>
	Company stamp/ signature	Company stamp/ signature	Company stamp/ signature	Company stamp/ signature

13 System inspection and maintenance

Additional maintenance work as-needed		Page	Date: _____	Date: _____
1.	Shut down the heating system	→ 40	<input type="checkbox"/>	<input type="checkbox"/>
2.	Remove and clean flue gas baffles	→ 42	<input type="checkbox"/>	<input type="checkbox"/>
3.	Clean the flue gas passages (heating surfaces)	→ 42	<input type="checkbox"/>	<input type="checkbox"/>
4.	Clean the combustion chamber	→ 42	<input type="checkbox"/>	<input type="checkbox"/>
5.	Clean the draft diverter	→ 43	<input type="checkbox"/>	<input type="checkbox"/>
6.	Insert the flue gas baffles	→ 43	<input type="checkbox"/>	<input type="checkbox"/>
7.	Check gaskets/sealant ropes on the burner and burner door and replace if required (see burner documentation)		<input type="checkbox"/>	<input type="checkbox"/>
8.	Commissioning the heating system	→ 37	<input type="checkbox"/>	<input type="checkbox"/>
9.	Record the final checks of the maintenance work, incl. measurements and test results		<input type="checkbox"/>	<input type="checkbox"/>
10.	Check safe and proper operation		<input type="checkbox"/>	<input type="checkbox"/>
	Confirm professional inspection		Company stamp/ signature	Company stamp/ signature

	Date: _____	Date: _____	Date: _____	Date: _____
1.	<input type="checkbox"/>	<input type="checkbox"/>	<input type="checkbox"/>	<input type="checkbox"/>
2.	<input type="checkbox"/>	<input type="checkbox"/>	<input type="checkbox"/>	<input type="checkbox"/>
3.	<input type="checkbox"/>	<input type="checkbox"/>	<input type="checkbox"/>	<input type="checkbox"/>
4.	<input type="checkbox"/>	<input type="checkbox"/>	<input type="checkbox"/>	<input type="checkbox"/>
5.	<input type="checkbox"/>	<input type="checkbox"/>	<input type="checkbox"/>	<input type="checkbox"/>
6.	<input type="checkbox"/>	<input type="checkbox"/>	<input type="checkbox"/>	<input type="checkbox"/>
7.	<input type="checkbox"/>	<input type="checkbox"/>	<input type="checkbox"/>	<input type="checkbox"/>
8.	<input type="checkbox"/>	<input type="checkbox"/>	<input type="checkbox"/>	<input type="checkbox"/>
9.	<input type="checkbox"/>	<input type="checkbox"/>	<input type="checkbox"/>	<input type="checkbox"/>
10.	<input type="checkbox"/>	<input type="checkbox"/>	<input type="checkbox"/>	<input type="checkbox"/>
	Company stamp/ signature	Company stamp/ signature	Company stamp/ signature	Company stamp/ signature

14 Troubleshooting burner faults

Heating system faults are shown on the display of the control panel. You will find detailed information regarding fault displays in the service instructions for the relevant control panel. The burner fault is also indicated by a fault lamp on the burner.



NOTICE: Risk of system damage from freezing.

The heating system can freeze up in cold weather if it has been disabled due to a fault shutdown.

- ▶ Rectify the fault immediately and restart the heating system.
- ▶ If this is not possible, drain the heating and DHW system-side at the lowest point.

Troubleshooting burner faults

- ▶ Press the burner reset button (see burner operating instructions).



NOTICE: Risk of system damage from too many resets.

- ▶ The burner ignition transformer may be damaged if you press the reset button more than three times in succession when the burner refuses to start.
- ▶ Do not attempt to remedy the fault by pressing the reset button more than three times in succession.

If the burner does not restart after three attempts, refer to the technical documentation provided with the burner to find out how to reset it.

15 Spare parts

- Request spare parts with name and part number using the spare parts list.

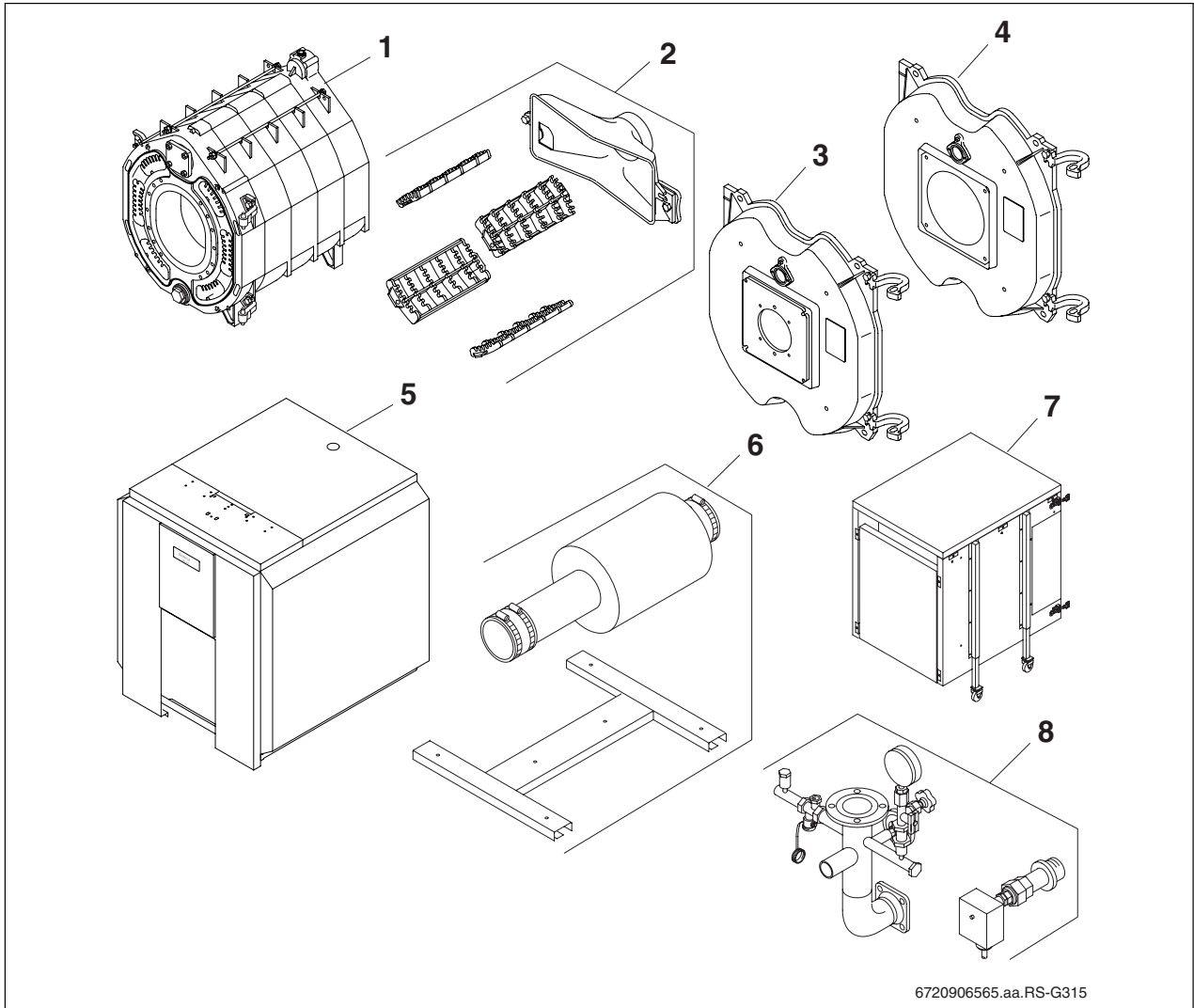

Fig. 62 Spare parts Logano G315

Item (→ Fig. 62)	Designation	Spare parts list
1	Group 1 – boiler block - front	→ page 51
2	Group 2 – boiler block - draft diverter	→ page 52
3	Group 3 – burner door G315	→ page 57
4	Group 4 – burner door G315 VM	→ page 59
5	Group 5 – jacket	→ page 61

Tab. 13 Spare part groups Logano G315

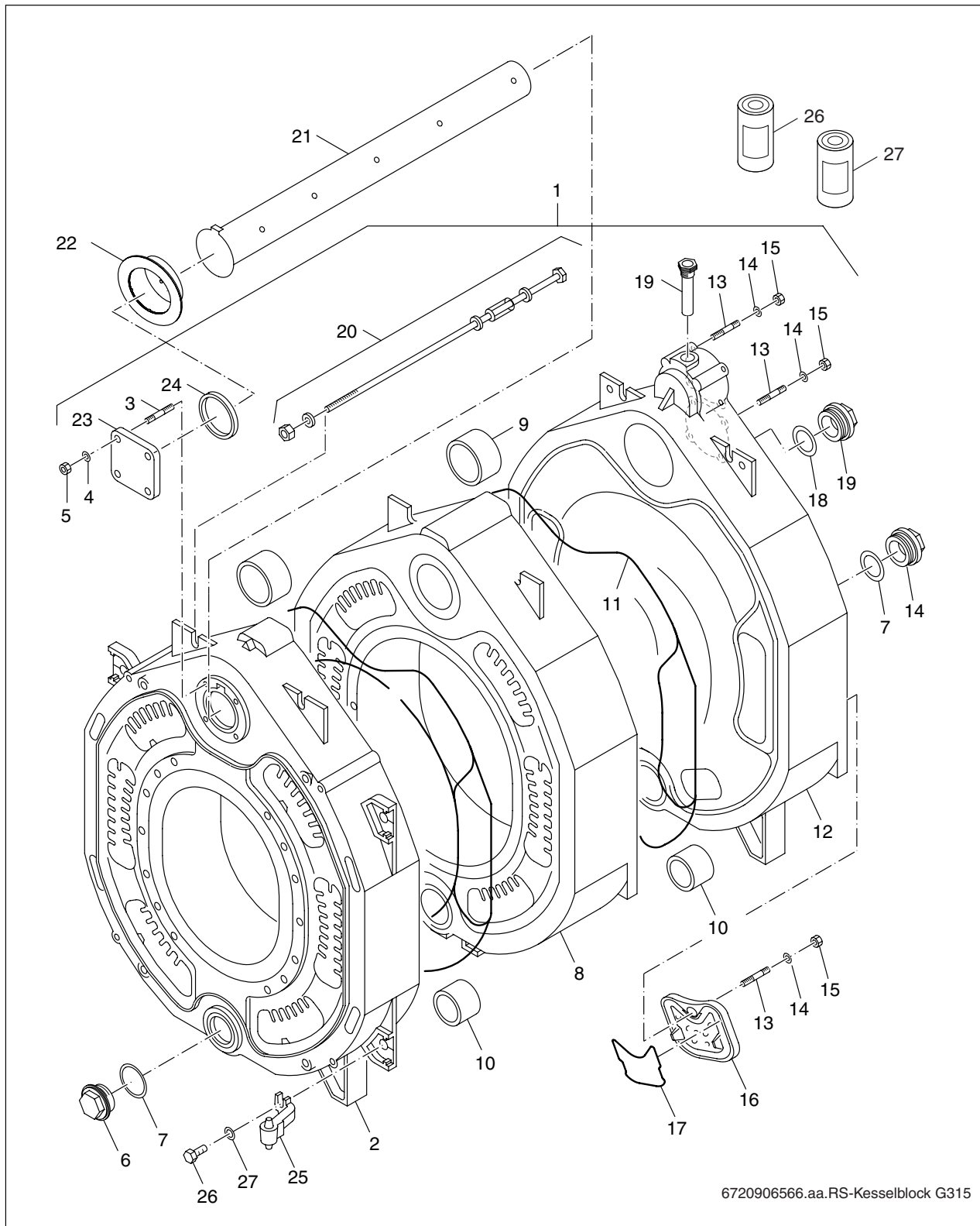

Fig. 63 Group 1 – boiler block - front Logano G315

Item (→ Fig. 63)	Designation	Order number
1	Boiler block assembled 5	5 178 820
	Boiler block assembled 6	5 178 822
	Boiler block assembled 7	5 178 824
	Boiler block assembled 8	5 178 826
	Boiler block assembled 9	5 178 828
	Boiler block unassembled 5	5 178 850
	Boiler block unassembled 6	5 178 852
	Boiler block unassembled 7	5 178 854
	Boiler block unassembled 8	5 178 856
	Boiler block unassembled 9	5 178 858
2	Front section G315	8 718 572 191 0
3	Threaded stud DIN939 M12x35	3 719 184
4	Washer DIN125-A13-A3K	5 883 276
5	Hexagon nut ISO4032 M12 8	5 090 068
6	Plug G 1 3/4	5 317 730
7	Gasket D54x70x2 mm	2 515 516
8	Intermediate section G315	8 718 572 192 0
9	Boiler nipple 119/50 Sz 2	7 747 024 966
10	Boiler nipple 55/50 Sz 0	7 747 024 964
11	Sealant rope D15x4300 20 KMVk Pack A=2	7 747 013 784
	Sealant rope D15x4300 20 KMVk Pack B=3 rolls	7 747 013 785
	Sealant rope D15x5050 20 KMVk Pack A=2	7 747 013 787
	Sealant rope D15x5050 20 KMVk Pack B=3	7 747 013 788
12	Rear section G315	8 718 572 217 0
13	Threaded stud DIN939 M12x35+	3 719 184
14	Reducer plugs G 1 3/4" x 3/4"	5 317 732
16	Cleanout cover compl. for rear section	5 371 905
17	Sealant rope GP10x1070 mm long	63 020 962
18	Gasket D33x44x2 mm	63 005 462
19	Plug G 1	5 317 712
	Plug G 1	5 446 065
20	Tie rod M12x705 compl.	5 127 902
	Tie rod M12x865 compl.	5 127 904
	Tie rod M12x1025 compl.	5 127 906
	Tie rod M12x1185 compl.	5 127 908
	Tie rod M12x1345 compl.	5 127 910
21	Supply pipe 5 pcs. compl G315	5 436 502
	Supply pipe 6 pcs. compl G315	5 436 504
	Supply pipe 7 pcs. compl G315	5 436 506
	Supply pipe 8 pcs. compl G315	5 436 508
	Supply pipe 9 pcs. compl G315	5 436 510
	Supply pipe 5 pcs. compl G315 VM	63 019 495
	Supply pipe 6 pcs. compl G315 VM	63 019 496
	Supply pipe 7 pcs. compl G315 VM	63 019 497
	Supply pipe 8 pcs. compl G315 VM	63 019 498
	Supply pipe 9 pcs. compl G315 VM	63 019 639
22	Supply pipe - studs VM	8 718 571 352 0

Tab. 14 Group 1 – boiler block - front Logano G315

Item (→ Fig. 63)	Designation	Order number
23	Flange cover square 110 mm	5 428 081
24	Gasket D72x96x1.5 mm	8 718 571 260 0
25	Hinge G315	5 327 444
26	Sealing compound brown	63 014 361
27	Ramming mass Calde Cast XL106 C/G 2.5 kg	7 747 027 148
	Fittings G315 5-pc loose spare	
	Fittings G315 6-pc loose spare	
	Fittings G315 7-pc loose spare	
	Fittings G315 8-pc loose spare	
	Fittings G315 9-pc loose spare	
	Primer 181, 12.5 oz (370 ml) in 17 oz (500 ml) can	
	Sealant graphite treated with linseed oil 450 g can	

Tab. 14 Group 1 – boiler block - front Logano G315

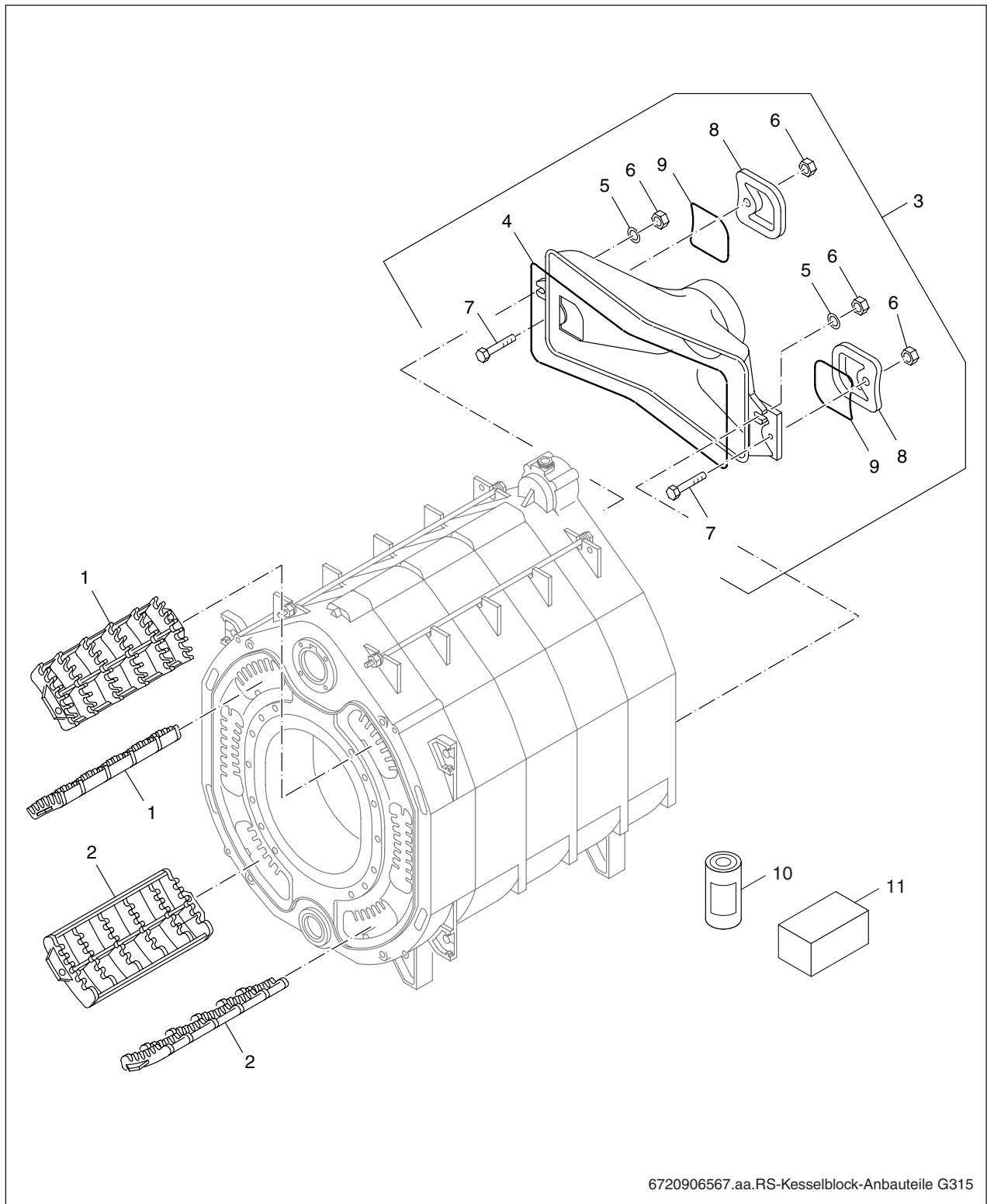

Fig. 64 Group 2 – boiler block - draft diverter Logano G315

Item (→ Fig. 64)	Designation	Order number
1	Flue gas baffle top 220 mm G315 for 9 segments	5 265 184
	Flue gas baffle top 380 mm G315 for 5/8 segments	5 265 186
	Flue gas baffle top 460 mm G315 for 6/7 segments	5 265 188
2	Flue gas baffle bottom 220 mm G315 for 9 segments	5 265 194
	Flue gas baffle bottom 380 mm G315 for 5/8 segments	5 265 196
	Flue gas baffle bottom 460 mm G315 for 6/7 segments	5 265 198
3	Draft diverter compl. G315	5 321 520
4	Sealant rope D15x4300 KMV pack	5 830 260
5	Washer DIN125-A13-A3K	5 883 276
6	Hexagon nut ISO4032 M12 8	5 090 068
7	Hex-head bolt ISO4017 M12x55	5 090 262
8	Cleanout cover compl. for	5 371 906
9	Sealant rope GP10x1070 mm long	63 020 962
10	Sealing compound brown	63 014 361
11	Maintenance package G315	63 006 595

Tab. 15 Group 2 – boiler block - draft diverter Logano G315

Item (→ Fig. 65)	Designation	Order number
1	Burner door compl. G315	63 015 443
2	VE sealant rope GP 14x10000	5 830 588
	VE sealant rope GP 14x2500	63 020 966
3	Thermal insulation burner door G315	63 002 419
4	Insulation plate for burner door GE 315	63 004 288
5	Insulation ring burner door G315	5 335 941
6	Hinge eye [70002675]	8 718 570 844 0
7	Washer DIN125-A13-A3K	5 883 276
8	Burner plate 270x270x10 mm	8 718 573 741 0
9	Burner plate 10x270x270 mm (D:140 mm)	5 431 312
10	Burner plate 10x270x270 mm (D:160 mm)	5 431 315
11	VE sealant rope GP 10x10000	5 830 584
	VE sealant rope GP10x1070 mm long	63 020 962
12	Washer DIN125 pcs. 10.5x2.0 mm	82 867 140
13	Inspection hole cover plate cpl.	63 037 570
14	Gasket D42x52x1.5 mm	5 752 520
15	Countersunk screw M5x16-DIN963-Ms	5 555 760
16	Pressure testing nipple, G1/8" set	7 747 022 048
17	Washer DIN9021 A6,4 A3K	5 264 166
18	Hex-head bolt ISO4017 M12x45 (10x)	8 718 575 468 0
20	Sealing compound brown	63 014 361
21	Ramming mass JM 500/G 3.5 kg	63 001 856

Tab. 16 Group 3 – burner door Logano G315

Item (→ Fig. 66)	Designation	Order number
1	Burner door G315 VM	63 035 670
2	Sealant rope 14x2500 GP	63 020 966
3	Thermal insulation burner door G315 VM	63 035 671
4	Insulation plate for burner door G315 VM	63 035 672
5	Insulation ring burner door G315	5 335 941
6	Hinge eye [70002675]	8 718 570 844 0
7	Washer DIN125-A13-A3K	5 883 276
8	Inspection hole cover plate cpl.	63 037 570
9	Countersunk screw M5x16-DIN963-MS	5 555 760
10	Gasket D42x52x1.5 mm	5 752 520
11	Pressure testing nipple, G1/8"	5 481 194
12	Hex-head bolt ISO4017 M12x45 (10x)	8 718 575 468 0
17	Washer DIN9021 A6,4 A3K	5 264 166
20	Sealing compound brown	63 014 361
21	Ramming mass JM 500/G 3.5 kg	63 001 856

Tab. 17 Group 4 – burner door Logano G315 VM

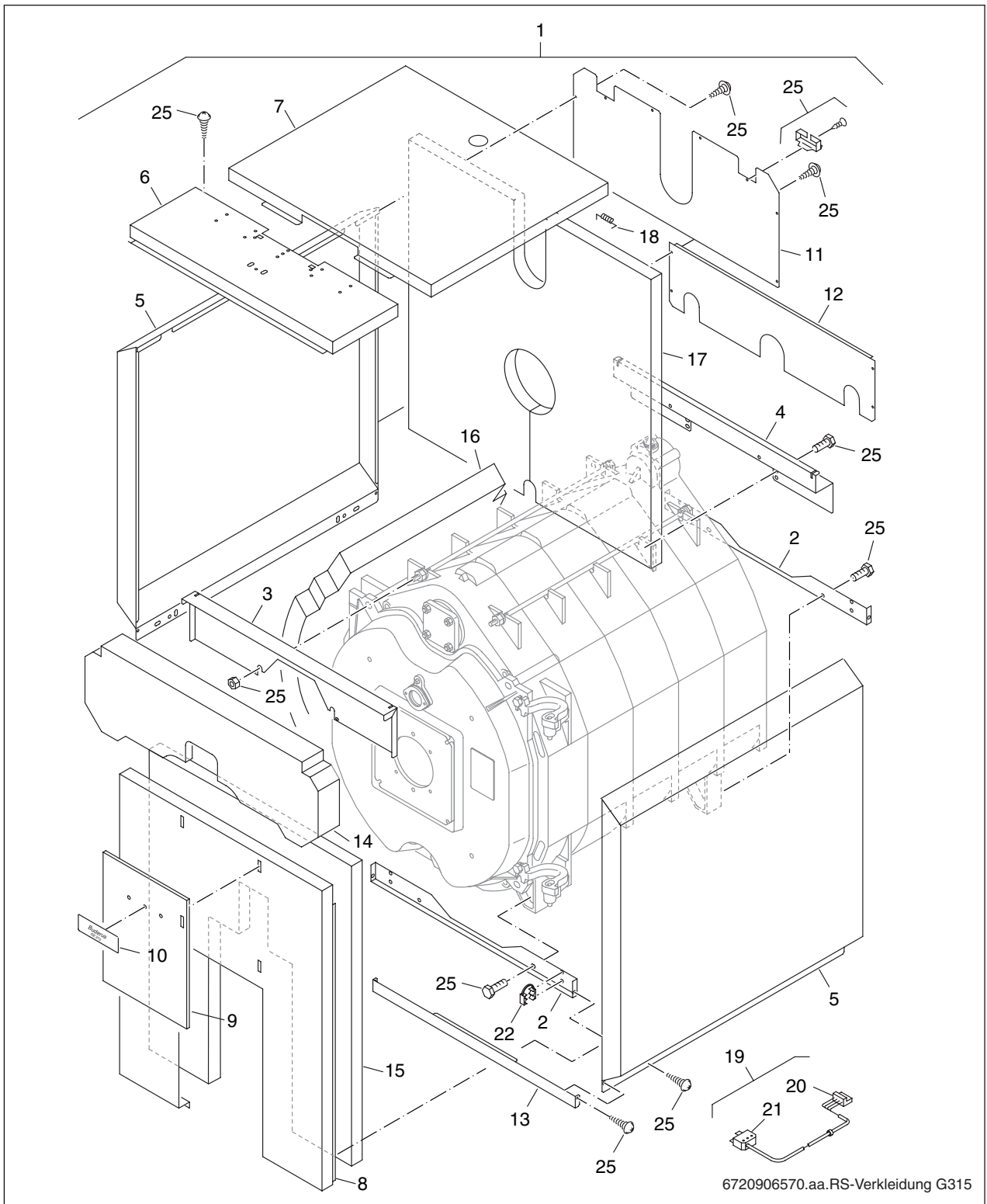

Fig. 67 Group 5 – jacket Logano G315

Item (→ Fig. 67)	Designation	Order number
1	Jacket compl. 5 sections G315	5 614 602
	Jacket compl. 6 sections G315	5 614 604
	Jacket compl. 7 sections G315	5 614 606
	Jacket compl. 8 sections G315	5 614 608
	Jacket compl. 9 sections G315	5 614 609
	Jacket G315 5pcs cpl VM V1	63 230 182
	Jacket G315 6pcs cpl VM V1	63 230 184
	Jacket G315 7pcs cpl VM V1	63 230 186
	Jacket G315 8pcs cpl VM V1	63 230 188
	Jacket G315 9pcs cpl VM V1	63 230 190
2	Bottom tie bar G315	5 614 642
3	Tie bar front top G315	5 614 640
4	Tie bar rear top G315	5 614 712
5	Side panel compl. 909 mm long 5 sections G315	5 614 612
	Side panel compl. 1069 mm long 6 sections G315	5 614 614
	Side panel compl. 1229 mm long 7 sections G315	5 614 616
	Side panel compl. 1389 mm long 8 sections G315	5 614 618
	Side panel compl. 1549 mm long 9 sections G315	5 614 700
6	Top cover front compl G315 V2	63 020 031
7	Top cover rear compl. 664 mm long 5 sections G315	5 614 624
	Top cover rear compl. 824 mm long 6 sections G315	5 614 626
	Top cover rear compl. 984 mm long 7 sections G315	5 614 628
	Top cover rear compl. 1144 mm long 8 sections G315	5 614 630
	Top cover rear compl. 1304 mm long 9 sections G315	5 614 644
8	Front panel compl. G315	5 614 632
9	Cover G315	63 011 714
10	Logano plus G315 name plate	63 014 097
	Appliance insignia plate Buderus Logano G315	>4/1999 67 902 826
	Logano plus G315 name plate	>4/1999 67 902 847
11	Rear panel top G315	5 614 634
12	Bottom rear panel G315	63 014 175
13	Base panel compl. G315	5 198 198
14	Thermal insulation front top G315	5 614 776
15	Thermal insulation front cover G315	5 614 774
16	Thermal insulation boiler block 840 mm	5 614 760
	Thermal insulation boiler block 1000 mm	5 614 762
	Thermal insulation boiler block 1160 mm	5 614 764
	Thermal insulation boiler block 1320 mm	5 614 766
	Thermal insulation boiler block 1480 mm	5 614 768
17	Thermal insulation rear panel G315	5 614 772
18	Retaining spring (10x)	7 747 016 084
25	Mounting material for jacket G315	5 614 740
	Burner hood G315 VM	63 020 282
	Cover Br-H G315 VM	63 020 283
	Logano G315 name plate	67 902 826

Tab. 18 Group 5 – jacket Logano G315

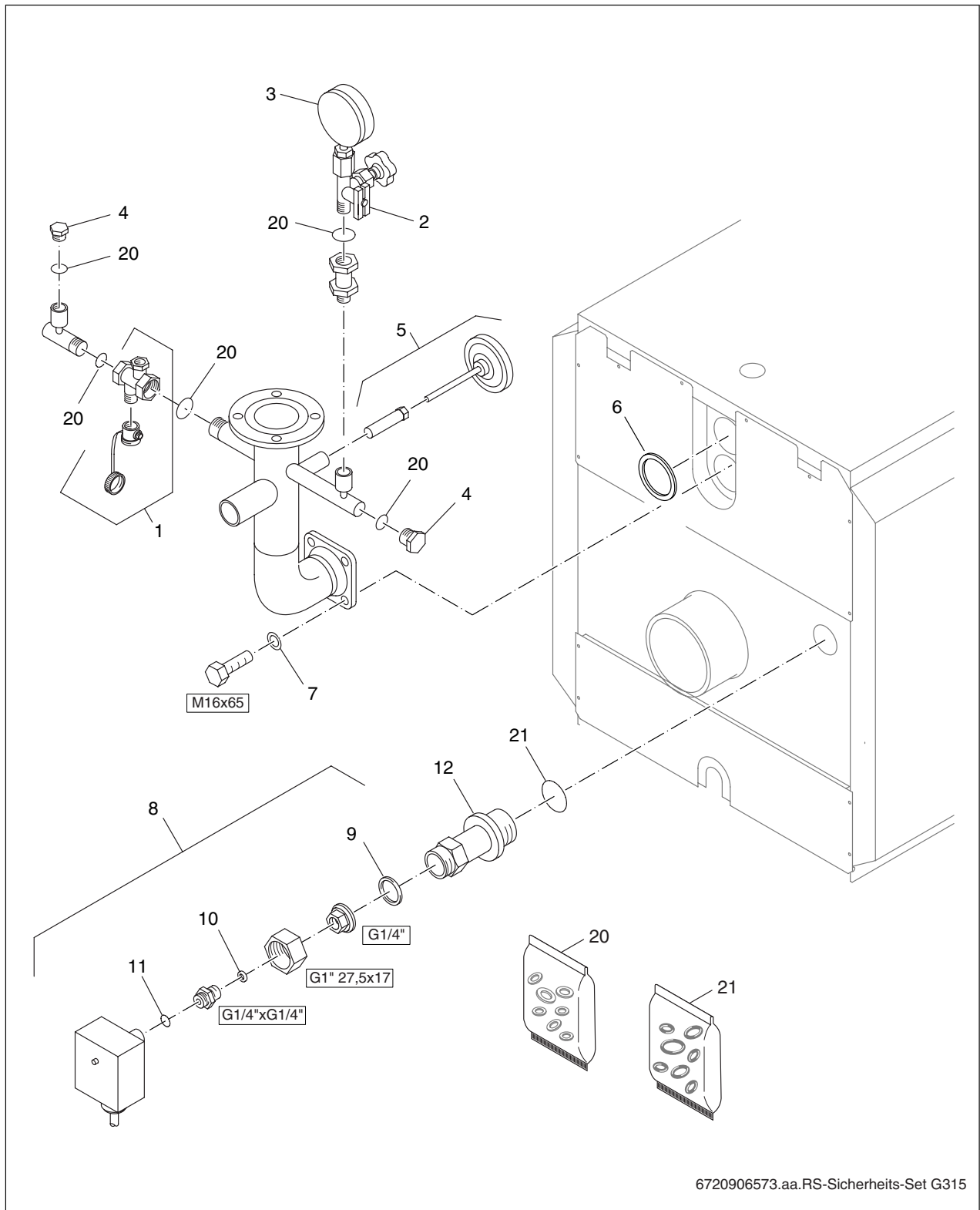

Fig. 68 Group 8 – safety group Logano G315

Item (→ Fig. 68)	Designation	Order number
1	Cap valve with drain & fill valve	5 639 600
2	OV pressure gauge block valve 1/2"AG, PN250,	81 504 600
3	Röhrenfeder pressure gauge d:100 mm, 0-10 bar	81 188 605
4	Set of grommets for safety armatures	5 639 660
5	Thermometer D100,g1/2.0-120degrees C,100lg	5 639 604
6	Seal DIN2690 DN65 2 mm	81 363 040
7	Washer DIN125-A17-A3K	3 869 840
8	Pressure regulator with adapter for KSS	5181 616
9	Gasket D24x30.5x2 mm (5x)	63 020 247
10	Gasket D6x11x2 mm AFM34 (5x)	8 718 571 893 0
11	O-ring D10x2 mm PERBUNAN (5x)	8 718 571 894 0
12	Double nipple G1" 104 lg	5 681 062
20	Gasket set KSG	5 639 634
21	Gasket set O-ring V1	5 354 969

Tab. 19 Group 8 – safety group Logano G315

Index

A

Added water 37

B

Boiler conditions of use 7

C

Control Panel Assembly 6

F

Fill water 37

Flow temperature 8

Fuels 7

O

Operating pressure, maximum 8

P

Product description 6

S

Safety instructions 4

T

Temperature control 8

Thermal insulation 6

Transport 14

Appendix

Data and system handover

Type _____

User _____

Manufacturer no. _____

Location _____

System installer _____

The system named above has been installed and commissioned according to standard engineering practice, as well as provisions of the buildings inspectorate and any legislative requirements.

The technical documentation has been handed over to the user. He has been familiarized with the safety instructions, operation and maintenance of the system.

Date, signature (system installer)

Date, signature (user)

----- please detach here -----



For use by system installer

Type _____

User _____

Manufacturer no. _____

Location _____

The technical documentation has been handed over to the user. He has been familiarized with the safety instructions, operation and maintenance of the system.

Date, signature (user)

United States and Canada

Bosch Thermotechnology Corp.
50 Wentworth Avenue
Londonderry, NH 03053
Tel. 603-552-1100
Fax 603-584-1681
www.buderus.us
U.S.A.

Products manufactured by
Bosch Thermotechnik GmbH
Sophienstrasse 30-32
D-35576 Wetzlar
www.buderus.com

Bosch Thermotechnology Corp. reserves the right
to make changes without notice due to continuing
engineering and technological advances.

Buderus