

For Residential and Commercial Applications

| | | | |
|----------------|--|----------------------|--|
| Job Name | | Engineer / Architect | |
| Job Location | | Wholesaler | |
| Submittal Date | | Contractor | |

G2CEPX09 / G2CEPX19 1/4 Turn Angle Stop - Cold Expansion Barb (for PEX) x Compression

Use: For use with water in accessible locations only. Not intended for recirculating systems that produce continuous use temperatures above 115° F. For those applications, use our KT™ series ball stop.

Design Features:

- **One-piece shut-off mechanism** provides smooth on-off operation without freeze ups even after long periods of non-use
- **Positive 1/4 turn** shut off
- **Full-flow operation** with no waterway obstructions
- **Corrosion-resistant handle** is plated in an attractive chrome finish
- **Machined one-piece brass body** provides strength, durability, and long-lasting performance
- **Easy-to-remove handle** with screw attachment helps protect against accidental operation during rough-ins
- **100% Leak** tested
-  **No Lead**
- **PEX end** designed to ASTM F1960
- **For use with** ASTM F876 PEX tubing, in ASTM F877 water distribution systems

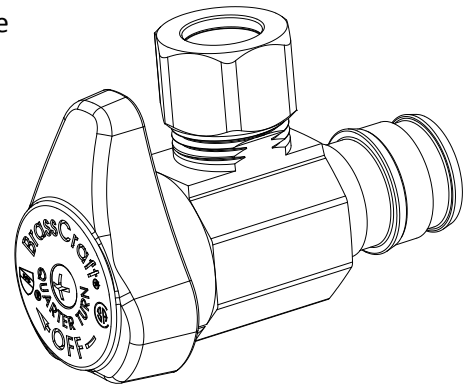

Operating Specifications:

Temperature: 40°- 140° F
Pressure: 125 PSI maximum

| STOP MATERIAL SPECIFICATIONS | |
|-------------------------------------|----------------------------|
| Body | Brass, chrome plated |
| Stem Barrel | Santoprene |
| Stem Shaft | Glass-filled polypropylene |
| Stem O-ring | Rubber |
| Handle | Zinc die cast, plated |
| Handle Screw | Zinc-plated steel |
| Compression Nut | Brass, chrome plated |
| Compression Sleeve | Brass |

This specification and all information contained herein is the confidential and exclusive property of BrassCraft Manufacturing, and shall not be disclosed to others without the written consent of BrassCraft Mfg. This specification must be returned to BrassCraft Mfg. if requested.



G2CEPX09 / G2CEPX19 1/4 Turn Angle Stop - Cold Expansion Barb (for PEX) x Compression

Part Listing:

- G2CEPX09X C 1/2" nom cold expansion barb (for PEX) x 1/4" OD compression, chrome plated
- G2CEPX19X C 1/2" nom cold expansion barb (for PEX) x 3/8" OD compression, chrome plated

| PART DIMENSIONS (Inches) | | | |
|---------------------------------|---------------|---------------|---------------|
| Model | DIM. A | DIM. B | DIM. C |
| G2CEPX09X | 1.02 | 2.13 | 1.49 |
| G2CEPX19X | 1.02 | 2.13 | 1.49 |

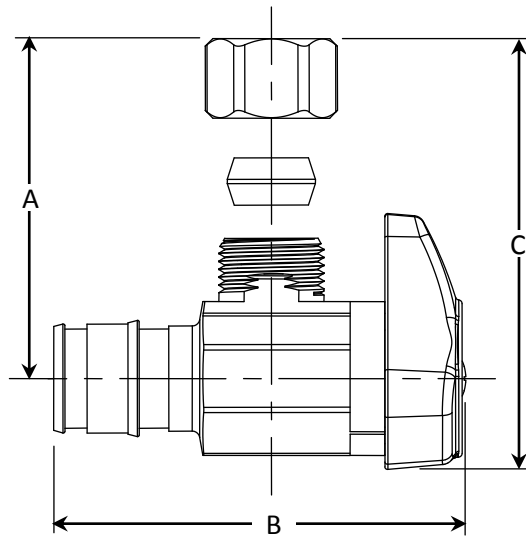

Listings & Certifications:

- IAPMO listed to ASME A112.18.1 / CSA B125.1 (File # 0645)
- CSA listed to ASME A112.18.1 / CSA B125.1 (File # 204593)
- No-Lead product CSA listed to Low Lead Content Certification Program – Plumbing Products Class 6853-01



This specification and all information contained herein is the confidential and exclusive property of BrassCraft Manufacturing, and shall not be disclosed to others without the written consent of BrassCraft Mfg. This specification must be returned to BrassCraft Mfg. if requested.