

INSTALLER: LEAVE THESE INSTRUCTIONS WITH HOME OWNER

FOR INSTALLATION IN THE RETURN AIR DUCT OF ANY FORCED AIR HEATING AND COOLING SYSTEM

TYPICAL INSTALLATIONS

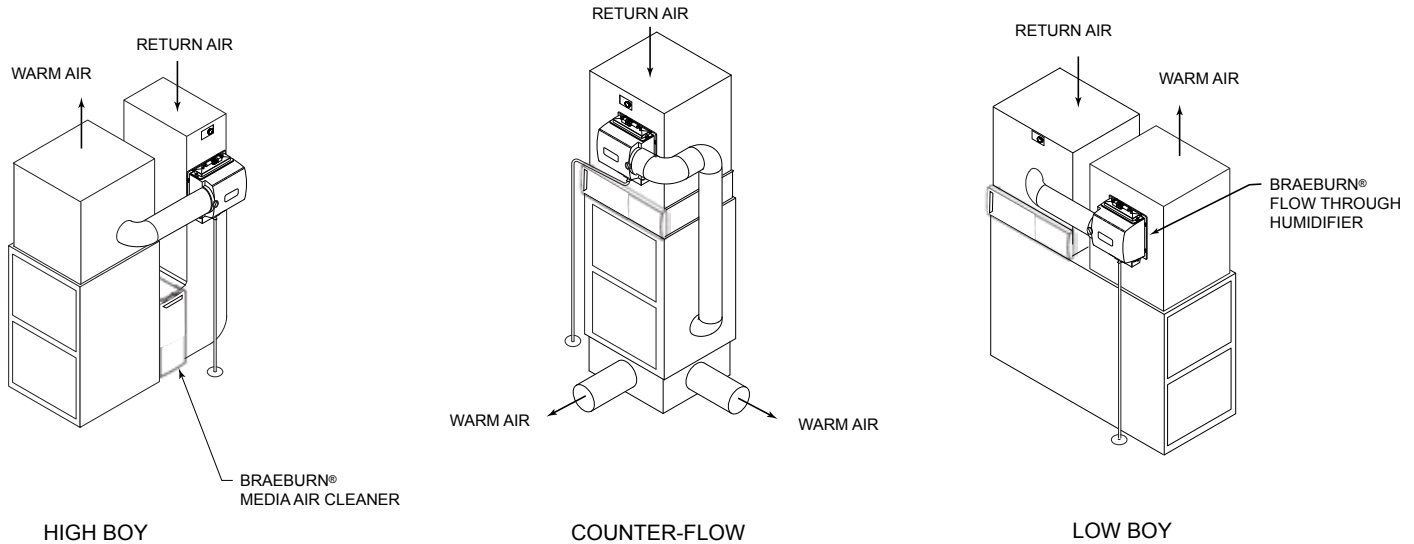

INSTALLATION INSTRUCTIONS

IMPORTANT: A 26 INCH CLEARANCE MUST BE ALLOWED FOR REMOVAL OF THE MEDIA CARTRIDGE FROM THE CABINET.

1. Turn off electricity to furnace.
2. Remove front cover.
3. Slide media cartridge from air cleaner cabinet, and discard packing material.
4. Remove and discard existing furnace air filter.
5. Install cabinet in return air system. Duct supports are recommended to support weight of cabinet. See typical installations.
6. Slide the media cartridge into the cabinet. Be sure the airflow arrow on the cartridge is pointing towards the furnace blower. The wire mesh is always on the downstream side of the filter media. Replace cover.
7. If the optional air filter gauge accessory (model 169000) is to be used, install on a vertical duct surface between the air cleaner and the furnace blower.
8. Turn on electricity and furnace and check performance of all equipment.

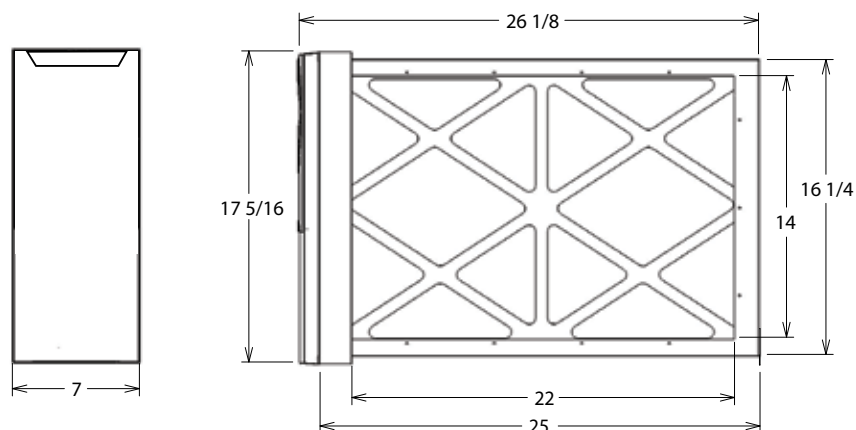

MAINTENANCE

The Air Cleaner Media will normally need to be replaced every 4 to 6 months (end of the heating or cooling season) with normal usage. If an air cleaner condition indicator is used, change the media when the device indicates that service is required. Additionally, the frequency of filter replacement can be determined by visual examination. Use Braeburn® media cartridge model 169016.

PARTS LIST

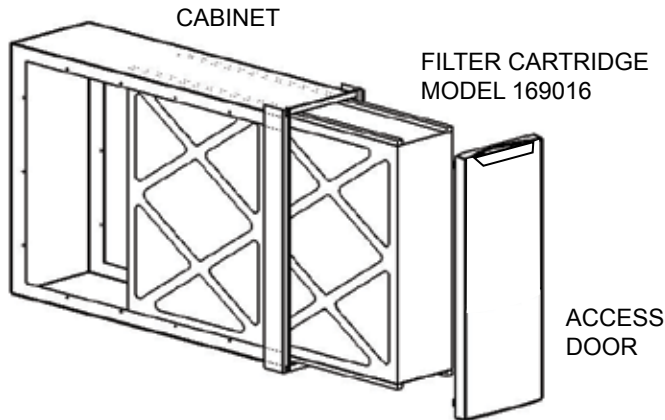

PRESSURE DROP SCHEDULE

CFM	IN W.C.
600	0.07
800	0.11
1000	0.16
1200	0.22
1400	0.28

LIMITED WARRANTY

Braeburn Systems LLC warrants each new Braeburn air cleaner against any defects that are due to faulty material or workmanship for a period of five years after the original date of purchase by a professional service technician. This warranty and our liability does not include damage to merchandise or the air cleaner resulting from accident, alteration, neglect, misuse, improper installation or any other failure to follow Braeburn installation and operating instructions.

Braeburn Systems LLC agrees to repair or replace at its option any Braeburn air cleaner under warranty provided it is returned postage prepaid to our warranty facility in a padded carton within the warranty period, with proof of the original date of purchase and a brief description of the malfunction. This limited warranty does not include the filter media, or the cost of removal or re-installation of the filter cabinet.

This warranty gives you specific legal rights and you may also have other rights that vary from state to state or province to province. Answers to any questions regarding our limited warranty may be obtained by writing our corporate offices.

WARRANTY FACILITY: Braeburn Systems LLC
Attn: Warranty Department
2215 Cornell Avenue
Montgomery, IL 60538



Braeburn®

Braeburn Systems LLC
2215 Cornell Avenue • Montgomery, IL 60538
Technical Assistance: www.braeburnonline.com
Call us toll-free: 866-268-5599 (U.S.)
630-844-1968 (Outside the U.S.)