



TA-48 (-BLK,-GREEN,-PVC) SERIES STANDARD SUBMERSIBLE TORQUE ARRESTOR

Features:

- Protects submersible pumps from starting torque damage
- Field-adjustable with snug fit
- Two piece design for quick installation
- Eliminates flashing problems

Specification:

- Materials: Thermo-Plastic Rubber (TPR)
Flexible Poly Vinyl Chloride (PVC)*

Certification:

- NSF/ANSI Standard 372 Certified

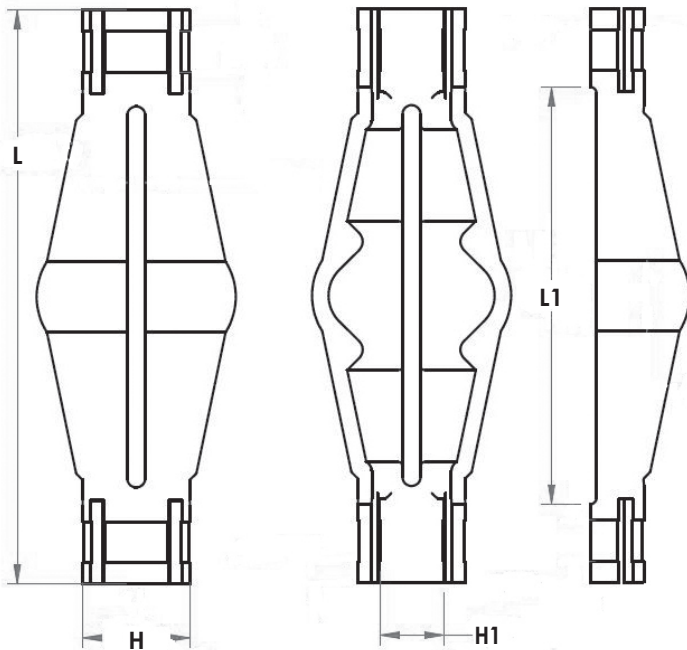
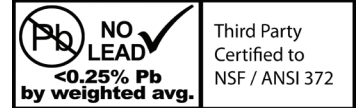

DIMENSIONS												
Part No.	Colour	Casing	Drop Pipe	H		H1		L		L1		Weight grams
		Size	Size	inches	mm	inches	mm	inches	mm	inches	mm	
TA-48-BLK	Black	4" to 8"	1" to 1-1/4"	2.22	56.39	1.32	33.53	11.88	301.75	8.63	219.20	454
TA-48-GREEN	Green	4" to 8"	1" to 1-1/4"	2.22	56.39	1.32	33.53	11.88	301.75	8.63	219.20	454
TA-48-PVC*	Black	4" to 8"	1" to 1-1/4"	2.22	56.39	1.00	25.40	11.88	301.75	8.38	212.85	454



25 Whaley Avenue, PO Box 310, Milverton, ON CANADA N0K 1M0
Tel: 519-595-4444 Fax: 519-595-4380 Toll Free: 800-561-3164

www.boshart.com