

2" DIAL STAINLESS STEEL PRESSURE GAUGE LIQUID FILLED LOWER MOUNT & CENTER BACK MOUNT

APPLICATION:

General purpose gauge, for potable water pumps & systems, these gauges are suitable for compressors, hydraulic presses, machinery, pneumatic equipment and motors, for most commercial air, water and steam services. To be used with fluid medium which does not clog connection or corrode copper alloy.

Not for use with oxygen, natural gas or propane.

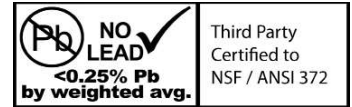

IMPORTANT: Liquid Filled Gauges are sealed with a rubber plug to prevent leaking during shipment. Upon installation the tip of the plug must be cut off in order for the gauge to vent, a small hole allows for equalization of the internal gauge pressure to the atmospheric pressure.

FAILURE TO DO SO WILL ADVERSELY EFFECT THE FUNCTION OF THE GAUGE.

Glycerin Temperature Rating: Gauges are filled with 99.7% concentration glycerin, which starts to become viscous at +63°F (17°C). As the temperature decreases, the more viscous glycerin becomes, which causes the pointer to move slower to its correct position. At 23°F (-5°C) these gauges will no longer operate. For operating temperatures lower than 23°F (-5°C), glycerin should be mixed 2 parts glycerin with 1 part water (66.7% concentration) which lowers the freezing point allowing the gauge to be used in temperatures as low as -51°F (-46°C).

CERTIFICATION:

- NSF/ANSI Standard 372 Certified

GAUGE SPECIFICATIONS	
Standard	ASME B40.1
Dial	2" (51mm) white aluminum dial
Case	304 Stainless Steel
Lens	Polycarbonate
Ring (Bezel)	304 Stainless Steel
Connection	316 Stainless Steel
Bourdon Tube	316 Stainless Steel
Fill Liquid	Glycerin (99.7% concentration)
Movement	316 Stainless Steel
Pointer	Aluminum (Anodized Black)
Welding	Argon
Working Pressure	Maximum 75% of Full Scale Value (F.S.V.)
Ambient Op. Temp.	-4°F to 140°F (-20°C to 60°C)
Media Op. Temp.	Max. 140°F (60°C)
Accuracy	+/- 1.5 % F.S.V.
Enclosure Rating	General Purpose



BOSHART
INDUSTRIES

25 Whaley Avenue, PO Box 310, Milverton, ON CANADA N0K 1M0
Tel: 800-561-3164

boshart.com ♦ blog.boshart.com

2" DIAL STAINLESS STEEL PRESSURE GAUGE LIQUID FILLED LOWER MOUNT & CENTER BACK MOUNT

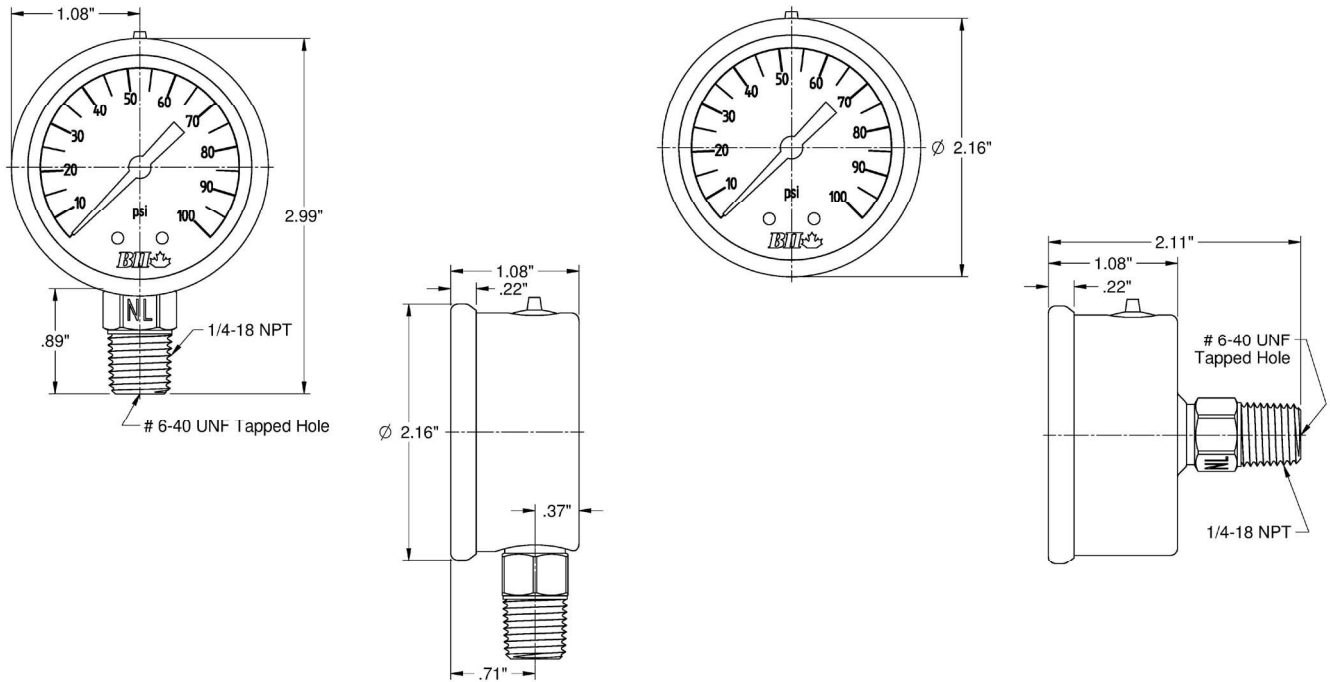

DIMENSIONS

Part No.	Connection	Range	Increments	Weight
		PSI		grams
LOWER MOUNT CONNECTION				
PGS-100-G	1/4" MPT	0-100	1	150
CENTER BACK MOUNT CONNECTION				
PGSCBM-100-G	1/4" MPT	0-100	1	130

BOSHART
INDUSTRIES

25 Whaley Avenue, PO Box 310, Milverton, ON CANADA N0K 1M0
Tel: 800-561-3164

boshart.com ♦ blog.boshart.com