

PEX Crimp Ball Valve w/ Hose Drain

Lead Free

FEATURES

- Lead Free – Ensures safe and effective use in drinking water systems
- Certifications: UPC/NSF61/NSF 372 – For safety and compliance in commercial and residential jobs
- PEX Crimp x PEX Crimp Connection – For a fast, secure installation
- Includes Hose Drain – For convenient system maintenance and draining
- Brass Construction – Provides excellent corrosion resistance and durability
- Lever Handle Style – Allows for easy operation and quick shutoff

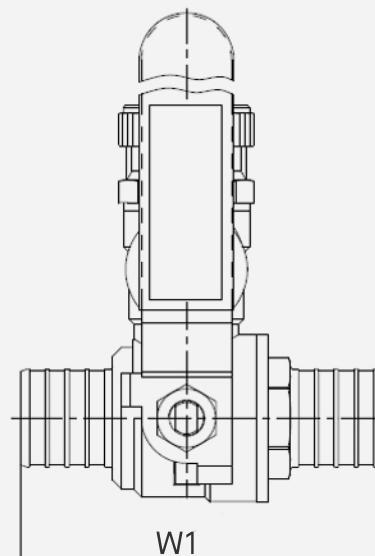
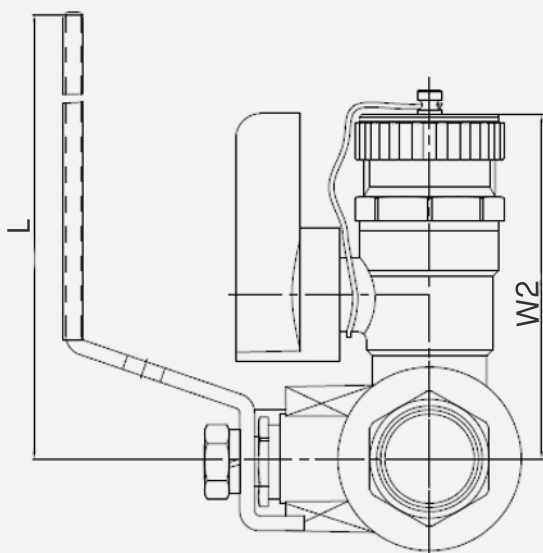

SKU	L	H	W1	W2
PXBV050HD	3.34"	2.71"	2.71"	2.62"
PXBV075HD	4.84"	2.71"	2.71"	2.62"
PXBV100HD	4.84"	2.91"	3.17"	2.62"