

PEX Crimp DZR Brass Ball Valve

Lead Free

FEATURES

- **Lead-free** – Made from certified lead-free EcoBrass UNS C69300 for exceptional protection against dezincification, stress corrosion, and cracking.
- **Safe for Drinking Water** - Meets ASTM F877, F-1807, and NSF/ANSI 61b standards for use in hot- and cold drinking water distribution systems.
- **Versatile** – Able to withstand a maximum working pressure of 230 PSI and a temperature range of -4° F to 200° F for use in a wide-variety of plumbing systems
- **PTFE and NBR Seals** – Provide excellent chemical resistance and durability.

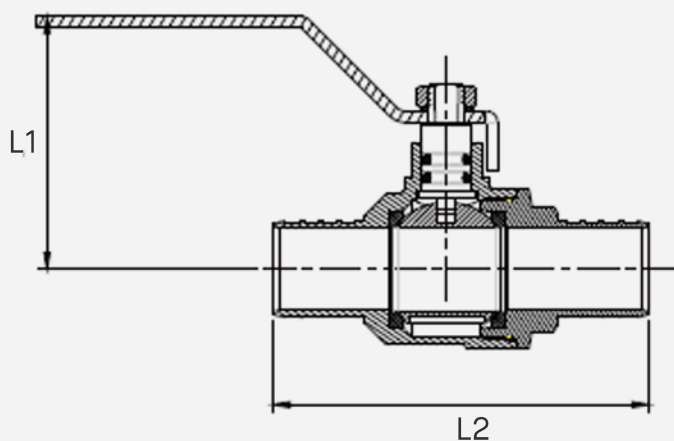

SKU	L1	L2
PXBV050-DZR	1.57"	2.59"
PXBV075-DZR	2.12"	2.71"
PXBV100-DZR	2.24"	3.35"