

Water Hammer Arrestor

3/8" O.D. Compression x 3/8" O.D. Female Compression Tee
Lead Free

FEATURES

- **Extends System Life** - Absorbs the energy from sudden changes in flow velocity to reduce stress caused by the water hammer.
- **"AA" Size** – Ideal for residential applications..
- **Pressure Tolerance** - Able to withstand a maximum working pressure of 350 psi.
- **Heat Resistance** – Able to withstand a maximum temperature of 300°F.
- **Fully-Compliant** – UPC listed and certified to ASSE 1010-2004 performance standards.

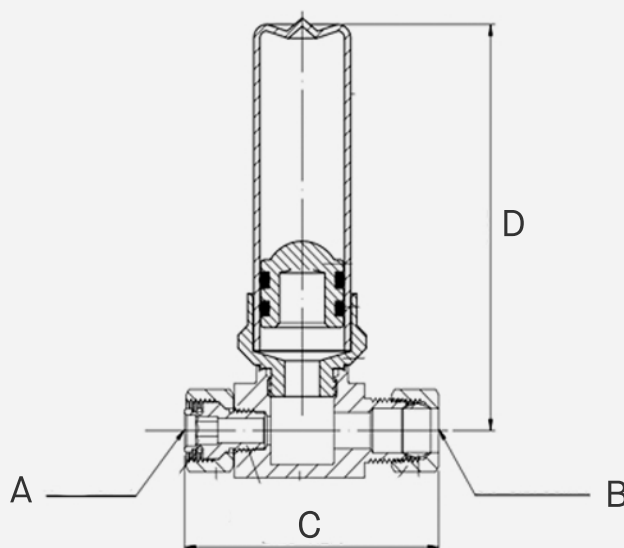

SKU	A	B	C	D
HA1-038	3/8" OD Female Compression	3/8" OD Compression	2.29"	3.52"