

Em-Lok Adjustable Swivel Ring, NFPA

Pre-Galvanized

FEATURES

- **Adjustable** - Allows for precise positioning and easy adjustments.
- **Carbon Steel Construction** – provides excellent strength and durability.
- **UL Listed, FM Approved** – This product has undergone rigorous testing and inspections to ensure that it's safe and reliable.

Complies with Federal specification WW-H-171E and American Manufacturers Standardization Society MSS SP-69 & SP58

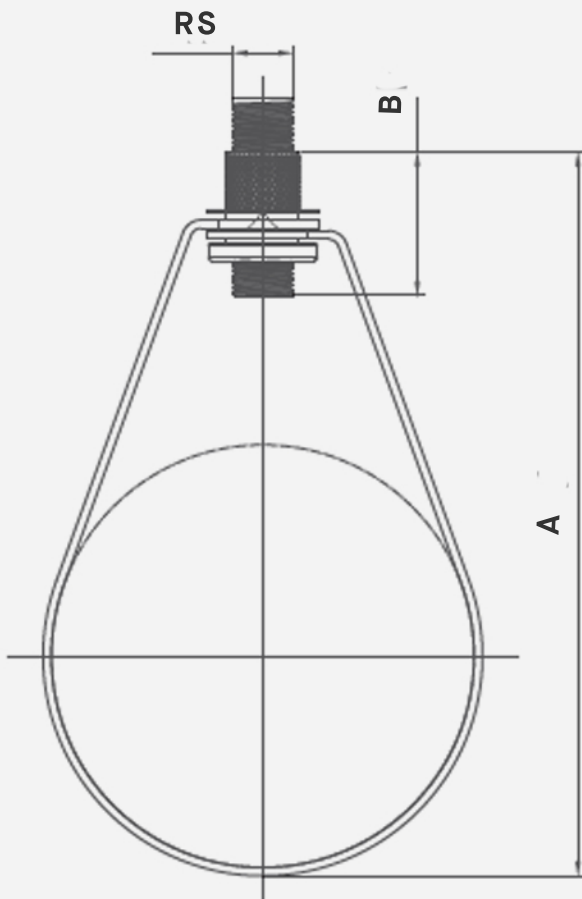

SKU	A	B	Rod Size (RS)	Max Load (lbs.)
GVSV300	6.38"	1-1/4"	3/8"	1000
GVSV400	7.67"	1-5/16"	3/8"	1100
GVSV500	9"	1-5/16"	1/2"	1100
GVSV600	10.5"	1-9/16"	1/2"	1250
GVSV800	12.5"	1- 5/8"	1/2"	1250