

# Electro-Galvanized Split Ring Extension Hanger

(Non-Hinged)

## FEATURES

- **Malleable Iron Construction** – makes the extension hanger strong yet easy to work with.
- **Electro-Galvanized Finish** – adds excellent protection against rust and corrosion.
- **Service** - Designed for the suspension of non-insulated stationary pipe lines horizontally or vertically.

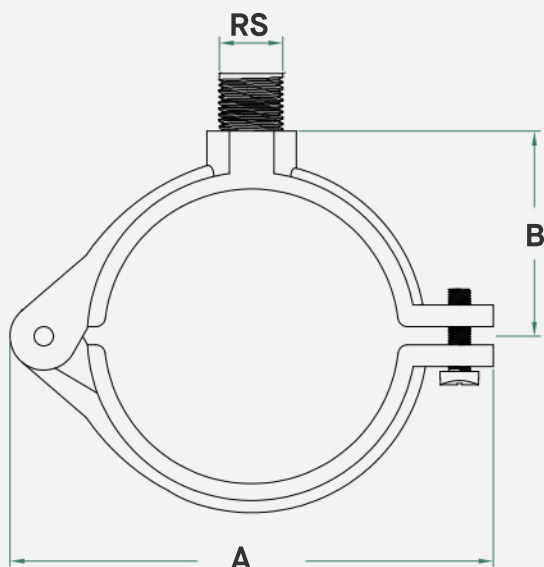

SKU	Size	A	B	Rod Size (RS)	Max Rec. Load (lbs)
GVSR050	1/2"	2.17"	0.71"	3/8"	180
GVSR075	3/4"	2.36"	0.80"	3/8"	180
GVSR100	1"	2.76"	0.98"	3/8"	180
GVSR125	1-1/4"	3.07"	1.15"	3/8"	180
GVSR150	1-1/2"	3.33"	1.26"	3/8"	180
GVSR200	2"	3.94"	1.56"	3/8"	180
GVSR250	2-1/2"	4.84"	2.06"	3/8"	300
GVSR300	3"	5.55"	2.48"	3/8"	300
GVSR400	4"	6.61"	2.99"	3/8"	300