

Gas Ball Valve

Brass Threaded FNPT x FNPT Gas Ball Valve

FEATURES

- **Versatile** – Able to withstand a maximum working pressure of 250 PSI and a temperature range of -4° F to 149° F for use in a wide-variety of plumbing systems.
- **Durable** - Equipped with a built-in packing nut, O-ring, and blowout-proof brass stem for a secure, long-lasting seal.
- **Fully compliant** - Meets ANSI B1.20.1 standards for threaded piping.

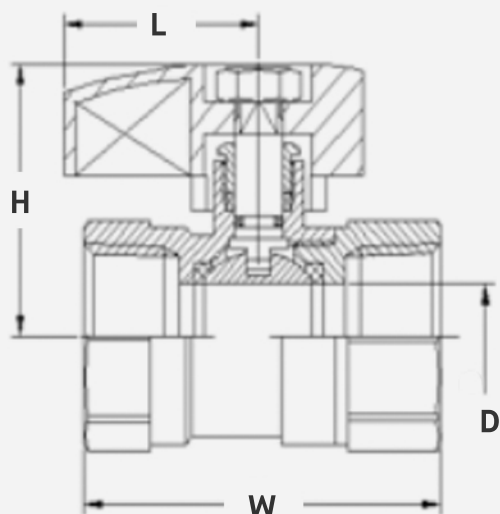

SKU	Size	D	L	H	W	Flow (m3/hr)
GBV038	3/8"	0.39"	1.30"	1.44"	1.75"	4.03
GBV050	1/2"	0.39"	1.30"	1.44"	2.20"	4.59
GBV075	3/4"	0.59"	1.30"	1.54"	2.36"	12.37
GBV100	1"	0.75"	1.30"	1.72"	2.87"	21.13