

20 Gallon Vertical Expansion Tank

FEATURES

- **Reliable Performance** - Controls pump cycling in residential well water systems.

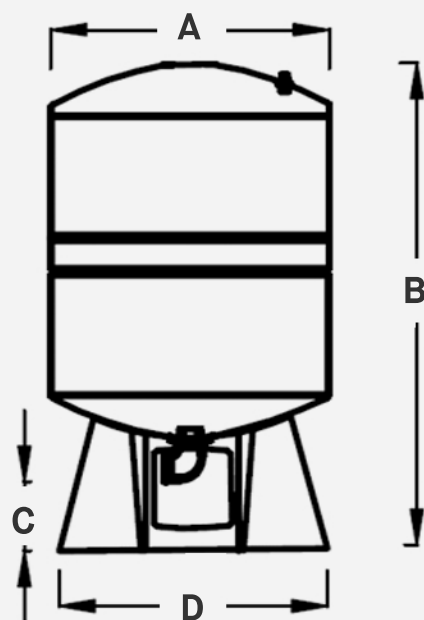

SKU	A	B	C	D
EXH20V	17.00"	28.00"	1-3/16"	14.00"

Capacity	20 Gal / 76 Lit
Shell	Steel
Diaphragm	Heavy Duty Butyl
Liner	Polypropylene
Finish	Grey
Maximum Operating Temperature	200°F (93°C)
Maximum Working Pressure	100 PSIG (6.9 bar)
Precharge Pressure	12 PSI
System Connection	1" FNPT
Connector Material	Steel
Stand	ABS