

# CPVC Ball Valve (Solvent)

Socket x Socket

## FEATURES

- **Versatile** - Rated at 100 PSI at 180°F for reliable performance with hot or cold water
- **Fully Compliant** – Meets NSF approved low lead standards and complies with ASTM D2846 for use on a wide-variety of residential and commercial projects
- **Built to Last** – Made with double EPDM O-rings and Teflon seats to resist corrosion from sunlight and ozone exposure

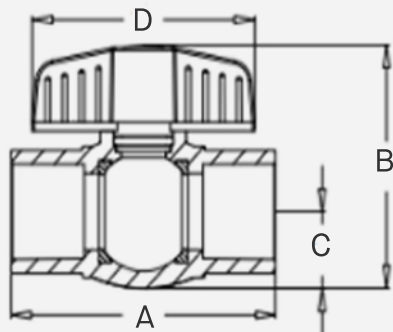

SKU	Size	A	B	C	D
CVBVS050	½"	2.574"	2.047"	0.630"	2.362"
CVBVS075	¾"	3.131"	2.506"	0.776"	2.732"
CVBVS100	1"	3.543"	2.953"	0.898"	2.996"