

Copper Crimp Valved Manifold

Male Sweat x Female Sweat w/ 1/2" PEX Crimp Ball Valves
(Lead Free)

FEATURES

- **Rated for Durability** - Able to withstand a maximum operating temperature of 180°F at 125 PSI
- **Safe for Drinking Water** - Meets ASTM F877 and F-1807 standards for use in hot- and cold drinking water distribution systems
- **Lead Free** - Listed by NSF Standards 14, 61, and 372
- **Fully Compliant** - Complies with B137.5 CSA Standard for safe and effective use in commercial and residential jobs

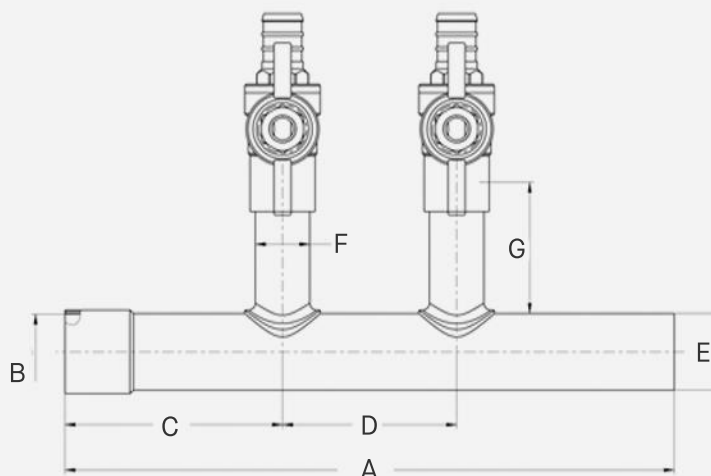

SKU	Branch	A	B	C	D/Revise	E	F	G
CM2-100SCA-PXV	2	7.5"	1.128"-1.132"	3"	2"/1	1.122"-1.127"	0.622"-0.626"	1.5"
CM3-100SCA-PXV	3	9.5"	1.128"-1.132"	3"	2"/2	1.122"-1.127"	0.622"-0.626"	1.5"
CM4-100SCA-PXV	4	11.5"	1.128"-1.132"	3"	2"/3	1.122"-1.127"	0.622"-0.626"	1.5"
CM11-100SCA-PXV	11	35.5"	1.128"-1.132"	3"	3"/10	1.122"-1.127"	0.622"-0.626"	1.5"