

Full Port Threaded Mini Ball Valve

Non-Potable Female IPS

FEATURES

- **Forged Brass Body** – Enhances the drain valve’s durability and longevity.
- **Rated for Durability** - Has a water, oil, and gas rating of 600psi and a working steam pressure of 150psi.
- **Stainless Steel Ball Valve** – For increased corrosion resistance.
- **Vinyl Grip** – For comfortable, non-slip operation.

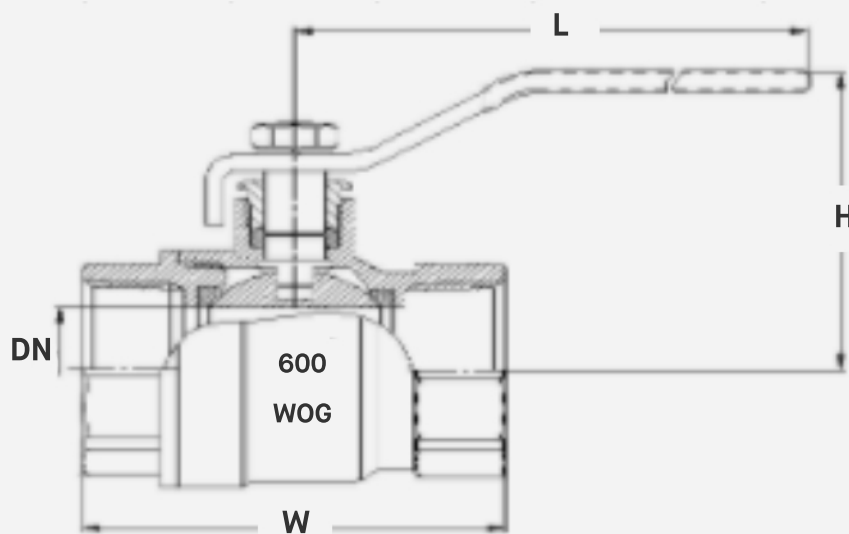

SKU	Size	DN	L	H	W	Cv	WT. (LBS)
BVT018-NP	1/8"	0.46"	3.46"	1.68"	1.73"	8.23	0.306
BVT050-NP	1/2"	0.52"	3.46"	1.73"	1.89"	14.56	0.337
BVT075-NP	3/4"	0.75"	3.46"	1.89"	2.28"	29.76	0.542
BVT100-NP	1"	0.98"	4.29"	2.14"	2.80"	51.55	0.928