

Threaded Ball Valve w/ Hose Drain

Lead Free

FEATURES

- **Lead Free** – Ensures safe and effective use in drinking water systems
- **Certifications: UPC/NSF61/NSF 372** – For safety and compliance in commercial and residential jobs
- **FNPT x FNPT Connection** – For a fast, secure installation
- **Includes Hose Drain** – For convenient system maintenance and draining
- **Brass Construction** – Provides excellent corrosion resistance and durability

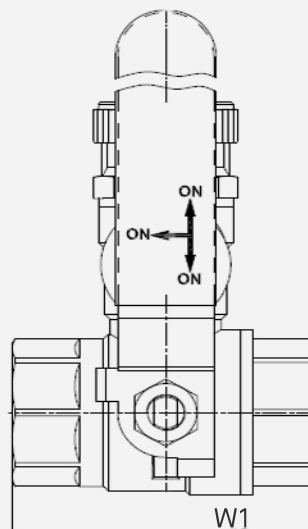
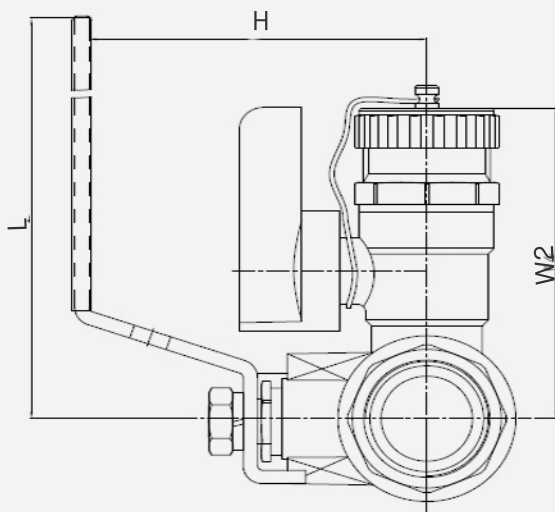

SKU	H	W1	W2	L
BVT050HD	2.71"	2.26"	2.72"	3.34"
BVT075HD	2.88"	2.5"	2.72"	4.84"
BVT100HD	3.03"	2.97"	2.74"	4.84"