

High Wall Heat Pump System

Location:	Approval:
Engineer:	Date:
Submitted to:	Construction:
Submitted by:	Unit #:
Reference:	Drawing #:



18,000 BTU R454B Plus Improved Efficiency Multi Zone Ductless Mini Split Air Conditioner and Heat Pump w/WIFI (Indoor)

Model: BFMS18PL-02I



INDOOR SPECIFICATION

Indoor Air Flow (Turbo/H/M/L/Si) (CFM)	759.3 / 500.3 / 441.4 / 370.8 //	
Indoor Noise Level (Turbo/H/M/L/Si) (dBA)	54/45/40.0/26/20	
Dimension (W×D×H)	inch	42.60 x 9.21 x 13.27
	mm	1082.0×234.0×337.0
Package (W×D×H)	inch	45.47 x 16.34 x 12.40
	mm	1155×415×315
Net/Gross Weight	lbs	30.42/39.68
	kg	13.8/18

OUTDOOR SPECIFICATION

Compressor Type	ROTARY	
Compressor Model	KSN140D58UFZ	
Refrigerant	R454B	
Refrigerant Oil Charge(mL)	440	
Refrigerant Oil	VG74	
Outdoor Air Flow (Max) (CFM)	1764.7	
Outdoor Noise Level (dBA)	59.0	
Dimension (W×D×H)	inch	35.04 x 13.46 x 26.50
	mm	890.0×342.0×673.0
Package (W×D×H)	inch	39.17 x 15.67 x 29.13
	mm	995×398×740
Net/Gross Weight	lbs	92.59/100.31
	kg	42.0/45.5

EFFICIENCY

Cooling		Heating	
SEER2	24.0	HSPF2-4	11.1
EER2	13.5	COP	3.81

PERFORMANCE of Cooling

Cooling (Btu/hr)	
Rated Capacity	18000
Min/Max Capacity	3600~20000
Moisture Removal(L/h)	1.4
Standard Operating Range(*F/*C)	-13~122(-25~50)
Conditions:	Indoor: 80°F DB/67°F WB Outdoor: 95°F DB/75°F WB

PERFORMANCE of Heating

Heating (Btu/hr)	
1. @ 47°F Rated	18000
1. @ 47°F Min/Max Capacity	7600~22000
2. @ 17°F Rated	13000
3. @ 5°F Rated: Capacity / COP	13000/2.35
3. @ 5°F Max: Capacity	13000
Standard Operating Range(*F/*C)	-13~75(-25~24)
1. Conditions:	Indoor: 70°F DB/60°F WB Outdoor: 47°F DB/43°F WB
2. Conditions:	Indoor: 70°F DB/60°F WB Outdoor: 17°F DB/15°F WB
3. Conditions	Indoor: 70°F DB/60°F WB Outdoor: 5°F DB/5°F WB

ELECTRICAL

Power Supply	208/230V, 60Hz, 1Ph
System MCA	18.0
Connection Wiring	14#x4
System MOCP	20
Compressor RLA	10.0
Outdoor Fan Motor RLA	0.9
Outdoor Fan Motor W	80
Indoor Fan Motor RLA	0.8
Indoor Fan Motor W	58
System Power Input @ Cooling (W)	1333(355 ~ 1700)
System Power Input @ Heating (W)	1385(410 ~1750)
MCA: Min. circuit amps (A)	MOCP: Max. over current protection (A)
RLA: Rated load amps (A)	W: Fan motor rated output (W)

PIPING

Throttle type(Indoor)	N/A
Throttle type(Outdoor)	EXV+Throttle valve
Liquid Size	6.35mm(1/4in)
Gas Size	12.7mm(1/2in)
Max. Piping Length(ft/m)	98.40(30)
Max. Height Difference(ft/m)	65.60(20)
Max. Pre-charged Length(ft/m)	24.6(7.5)
Refrigerant Pre-charged Amount(oz/g)	47.97(1.36)
Additional Charge of Refrigerant((oz/ft)/(g/m)	0.16(15)
Connection Method	Flared

Indoor Unit Dimension

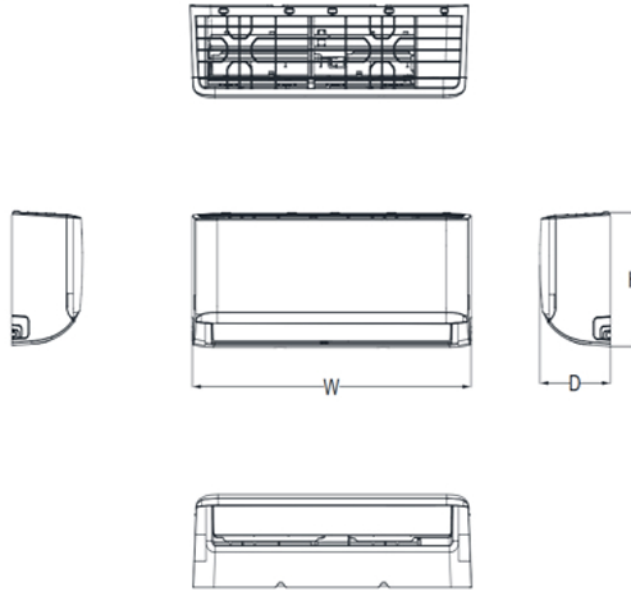

Capacity	Body Code	W(inch/mm)	D(mm/inch)	H(mm/inch)
6K~9K	A	28-3/4in /729mm	7-7/8in /200mm	11-1/2in /292mm
9K~12K	B	31-5/8in /802mm	7-7/8in /200mm	11-5/8in /295mm
18K	C	38-1/4in /971mm	9in/228mm	12-5/8in /321mm
18K~24K	D	42-5/8in /1082mm	9-1/4in/234mm	13-1/4in /337mm
30K~36K	F	49-5/8in /1259mm	11-1/8in/283mm	14-1/4in /362mm

Installation Instruction

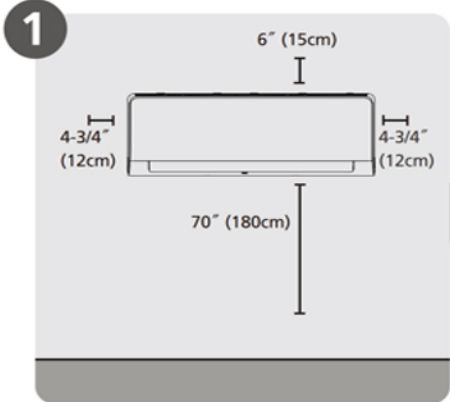

Select Installation Location

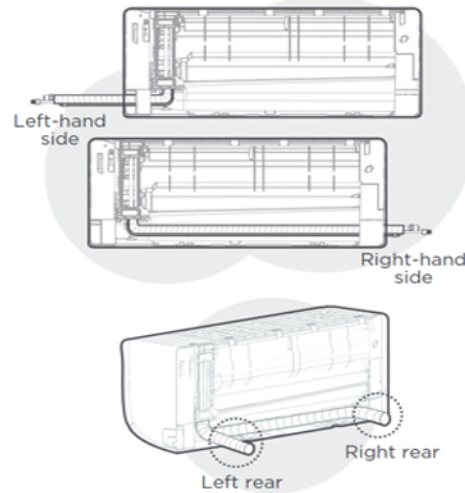

NOTE:
Based on the position of the wall hole relative to the mounting plate, choose the side from which the piping will exit the unit. You have four options for the exit direction of the

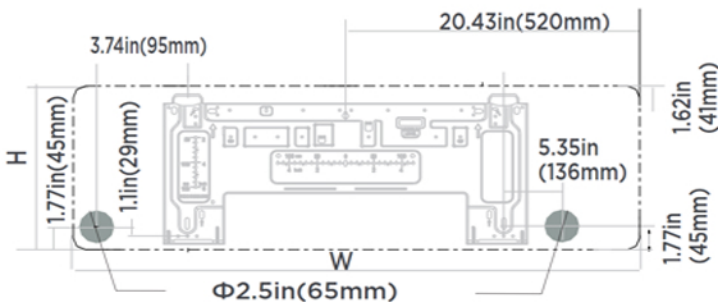

Indoor unit dimensions(WxH):
38.2in(971mm)x12.6in(321mm)

NOTE:
When the gas side connective pipe is Φ (5/8in)16mm or more, the wall hole should be (3-1/2in)90mm.