

High Wall Heat Pump System

Location:	Approval:
Engineer:	Date:
Submitted to:	Construction:
Submitted by:	Unit #:
Reference:	Drawing #:



12,000 BTU R454B Plus Improved Efficiency Multi Zone Ductless Mini Split Air Conditioner and Heat Pump w/WIFI (Indoor)

Model: BFMS12PL-02I



INDOOR SPECIFICATION

Indoor Air Flow (Turbo/H/M/L/Si) (CFM)	382.6 / 294.3 / 194.2 / 153.0 //	
Indoor Noise Level (Turbo/H/M/L/Si) (dBA)	46/43/37/20/19	
Dimension (W×D×H)	inch	31.57 x 7.87 x 11.61
	mm	802.0×200.0×295.0
Package (W×D×H)	inch	34.45 x 11.22 x 14.96
	mm	875×285×380
Net/Gross Weight	lbs	18.96/24.25
	kg	8.6/11

OUTDOOR SPECIFICATION

Compressor Type	ROTARY	
Compressor Model	KSK103D33UEZ3	
Refrigerant	R454B	
Refrigerant Oil Charge(mL)	310	
Refrigerant Oil	VG74	
Outdoor Air Flow (Max) (CFM)	1235.3	
Outdoor Noise Level (dBA)	54.0	
Dimension (W×D×H)	inch	30.12 x 11.93 x 21.85
	mm	765.0×303.0×555.0
Package (W×D×H)	inch	34.92 x 13.27 x 24.02
	mm	887×337×610
Net/Gross Weight	lbs	62.17/67.68
	kg	28.2/30.7

EFFICIENCY

Cooling		Heating	
SEER2	23.1	HSPF2-4	11.5
EER2	12.2	COP	3.69

PERFORMANCE of Cooling

Cooling (Btu/hr)	
Rated Capacity	12000
Min/Max Capacity	2600~13700
Moisture Removal(L/h)	1.3
Standard Operating Range(*F/*C)	-13~122(-25~50)
Conditions:	Indoor: 80°F DB/67°F WB Outdoor: 95°F DB/75°F WB

PERFORMANCE of Heating

Heating (Btu/hr)	
1. @ 47°F Rated	12000
1. @ 47°F Min/Max Capacity	4100~14400
2. @ 17°F Rated	9600
3. @ 5°F Rated: Capacity / COP	8600/2.35
3. @ 5°F Max: Capacity	8600
Standard Operating Range(*F/*C)	-13~75(-25~24)
1. Conditions:	Indoor: 70°F DB/60°F WB Outdoor: 47°F DB/43°F WB
2. Conditions:	Indoor: 70°F DB/60°F WB Outdoor: 17°F DB/15°F WB
3. Conditions:	Indoor: 70°F DB/60°F WB Outdoor: 5°F DB/5°F WB

ELECTRICAL

Power Supply	208/230V,60Hz,1Ph
System MCA	12.0
Connection Wiring	14#x4
System MOCP	15
Compressor RLA	7.3
Outdoor Fan Motor RLA	0.6
Outdoor Fan Motor W	34
Indoor Fan Motor RLA	0.5
Indoor Fan Motor W	13
System Power Input @ Cooling (W)	984(175 ~ 1210)
System Power Input @ Heating (W)	953(225 ~1290)
MCA: Min. circuit amps (A)	MOCP: Max. over current protection (A)
RLA: Rated load amps (A)	W: Fan motor rated output (W)

PIPING

Throttle type(Indoor)	N/A
Throttle type(Outdoor)	EXV
Liquid Size	6.35mm(1/4in)
Gas Size	9.52mm(3/8in)
Max. Piping Length(ft/m)	82.00(25)
Max. Height Difference(ft/m)	49.20(15)
Max. Pre-charged Length(ft/m)	24.6(7.5)
Refrigerant Pre-charged Amount(oz/g)	32.45(0.92)
Additional Charge of Refrigerant((oz/ft)/(g/m)	0.16(15)
Connection Method	Flared

Indoor Unit Dimension

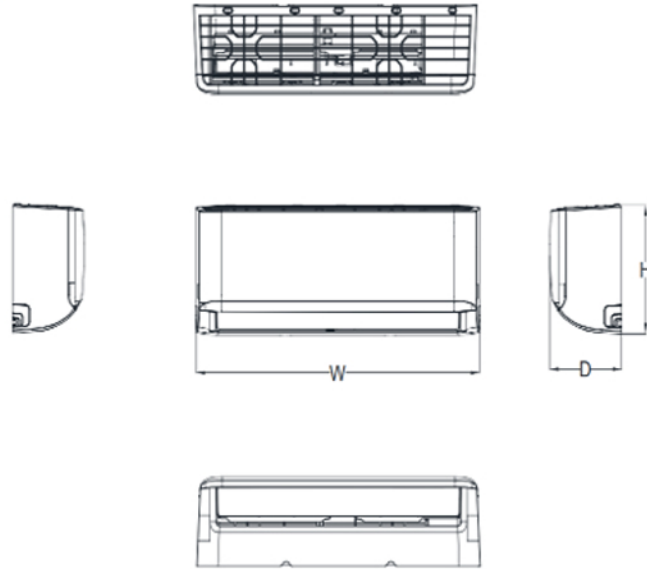

Capacity	Body Code	W(inch/mm)	D(mm/inch)	H(mm/inch)
6K~9K	A	28-3/4in /729mm	7-7/8in /200mm	11-1/2in /292mm
9K~12K	B	31-5/8in /802mm	7-7/8in /200mm	11-5/8in /295mm
18K	C	38-1/4in /971mm	9in/228mm	12-5/8in /321mm
18K~24K	D	42-5/8in /1082mm	9-1/4in/234mm	13-1/4in /337mm
30K~36K	F	49-5/8in /1259mm	11-1/8in/283mm	14-1/4in /362mm

Installation Instruction

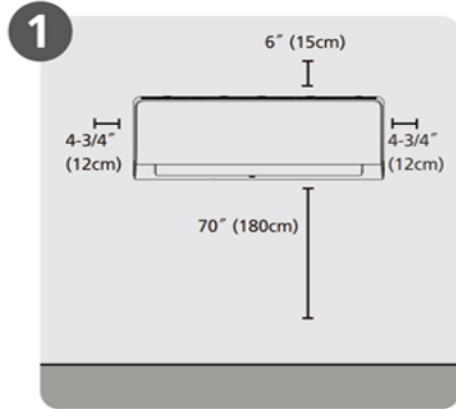

Select Installation Location

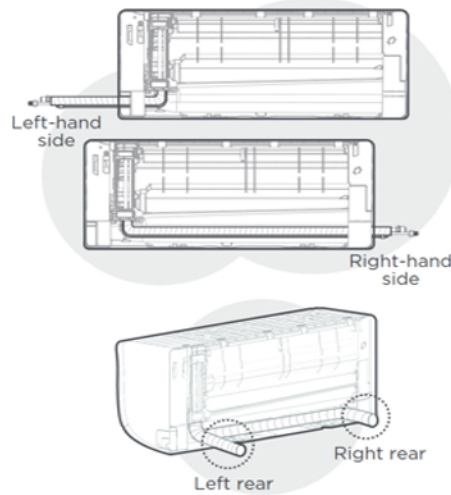

NOTE:
Based on the position of the wall hole relative to the mounting plate, choose the side from which the piping will exit the unit. You have four options for the exit direction of the

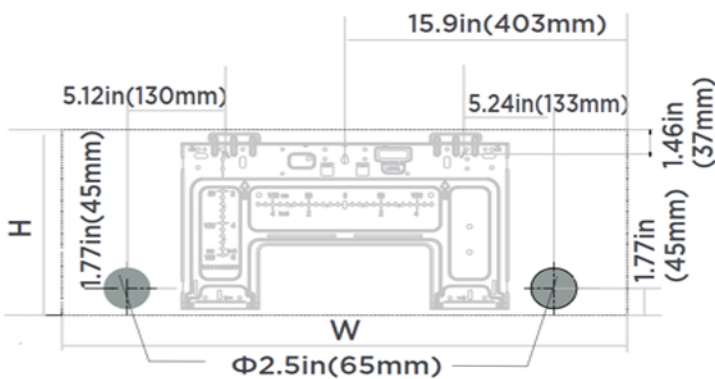

NOTE:
When the gas side connective pipe is Φ (5/8in)16mm or more, the wall hole should be (3-1/2in)90mm.

Indoor unit dimensions(WxH):
31.7in(806mm)x11.65in(296mm)