

# Brass Boiler Drain Valve

MNPT x MNH (Non - Potable)

## FEATURES

- **Forged Brass Body** – enhances the drain valve’s durability and longevity.
- **Fully Compliant** - Meets cUPC, NSF/ANSI 61, and NSF372/ANSI 372 standards.
- **For Non-Potable Applications** – Not for use in systems that handle drinking water.

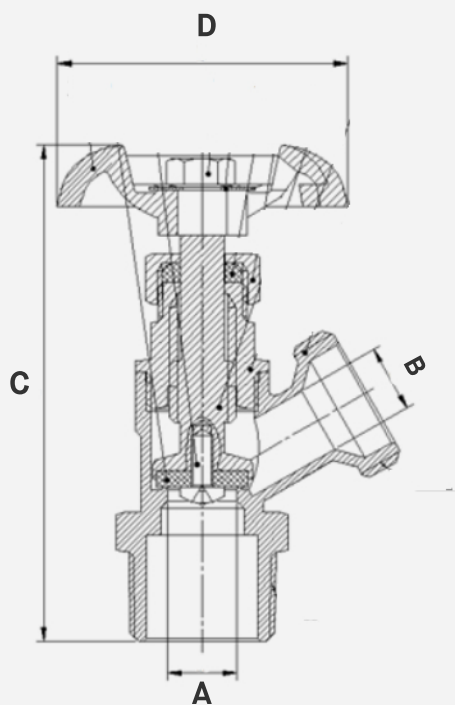

SKU	Size	A	B	C	D
BDM050-NP	1/2"	0.43"	0.47"	3.46"	2.05"
BDM075-NP	3/4"	0.43"	0.47"	3.54"	2.05"