

# Brass Boiler Drain Valve

FNPT x MNH (Non-Potable)



## FEATURES

- Forged Brass Body – enhances the drain valve’s durability and longevity
- Lead Free – Meets cUPC, NSF/ANSI 61, and NSF372/ANSI 372 standards for lead-free water components
- For Non-Potable Applications – Not for use in systems that handle drinking water

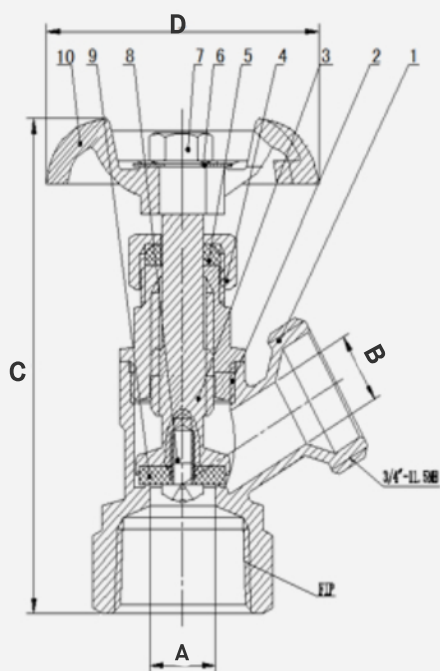

PART NO.	SIZE	A	B	C	D
BDF050	1/2"	0.433	0.472	3.15	2.050
BDF075	3/4"	0.433	0.472	3.25	2.050