

# LMCB24-3 (-T)

On/Off-Floating Point Control, Non-Spring Return, Direct Coupled, 24 V



Technical Data	LMCB24-3... on/off-floating
Power Supply	24 VAC ± 20% 50/60 Hz 24 VDC ± 10%
Power Consumption	1.5 W (0.2 W)
Transformer Sizing	3 VA (Class 2 power source)
Electrical Connection	3 ft, 18 GA plenum rated cable 3 ft, 18 GA appliance rated cable (-S) 1/2" conduit connector
Overload Protection	electronic throughout 0 to 95° rotation
Control	on/off, floating point
Input Impedance	600Ω
Angle of Rotation	max. 95°, adjust. with mechanical stop
Torque	45 in-lb [5 Nm]
Direction of Rotation	reversible with ↻/↻ switch
Position Indication	reflective visual indicator (snap-on)
Manual Override	external push button
Running Time	35 seconds, constant independent of load
Humidity	5 to 95% RH non condensing (EN 60730-1)
Ambient Temperature	-22°F to +122°F [-30°C to +50°C]
Storage Temperature	-40°F to +176°F [-40°C to +80°C]
Housing	NEMA 2/IP54
Housing Material	UL94-5VA
Agency Listings†	cULus acc. to UL60730-1A/-2-14, CAN/CSA E60730-1, CSA C22.2 No. 24-93, CE acc. to 89/336/EEC
Noise Level	<45dB(A)
Servicing	maintenance free
Quality Standard	ISO 9001
Weight	1.1lbs [0.5 Kg],

## LMCB24-3-T

Electrical connection	Screw terminal (for 26 to 14 GA wire)
Housing	NEMA 1/IP20

†Rated Impulse Voltage 800V, Type of action 1,  
Control Pollution Degree 3.

**Torque min. 45 in-lb for control of damper surfaces up to 11 sq ft.**

LMCB24-3  
LMCB24-3-T

### Application

For on-off and floating point control of dampers in HVAC systems. Actuator sizing should be done in accordance with the damper manufacturer's specifications.

The actuator is mounted directly to a damper shaft from 1/4" up to 5/8" in diameter by means of its standard universal clamp. Shafts up to 3/4" diameter can be accommodated by an accessory clamp.

### Operation

The actuator is not provided with and does not require any limit switches, but is electronically protected against overload. The anti-rotation strap supplied with the actuator will prevent lateral movement.

The LMB series provides 95° of rotation and a visual indicator which indicates position of the actuator. When reaching the damper or actuator end position, the actuator automatically stops. The gears can be disengaged with manual release on the actuator cover.

The LMCB24-3... actuators use a sensorless Brushless DC motor, which is controlled by an Application Specific Integrated Circuit (ASIC). The ASIC monitors and controls the actuator's rotation and provides a digital rotation sensing (DRS) function to prevent damage to the actuator in a stall condition. Power consumption is reduced in holding mode.

Add on auxiliary switches or feedback potentiometers are easily fastened directly onto the actuator body for signaling and switching functions.

### Dimensions (All numbers in brackets are in millimeters.)

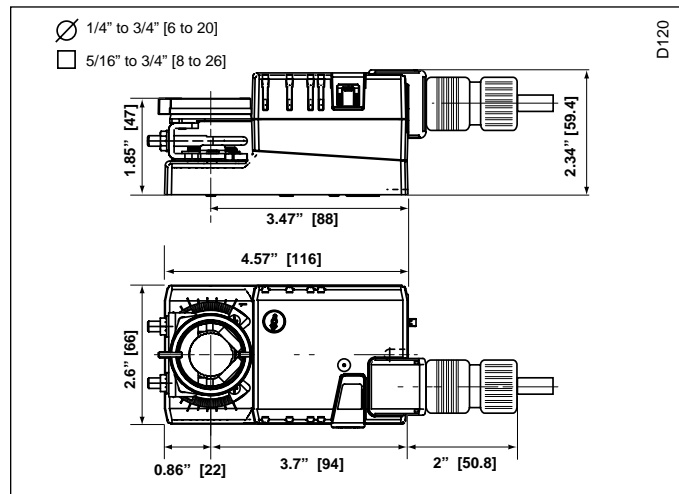

### Accessories

K-LM20	3/4" [20 mm] Shaft Clamp
AV6-20	Shaft Extension
ZG-LMSA	Shaft Adaptor for 1/2" Diameter Shafts
ZG-LMSA-1	Shaft Adaptor for 3/8" Diameter Shafts
ZS-T	Terminal Cover for NEMA 2
ZS-100	Weather Shield - Steel
ZS-150	Weather Shield - Polycarbonate
Tool-06	8 mm & 10 mm Wrench
S1A, S2A	Auxiliary Switch (es)
P370	Shaft Mount Auxiliary Switch
P...A	Feedback Potentiometers

**Note:** When using LMCB24-3... actuators, only use accessories listed on this page.

### LMCB24-3 - Typical Specification:

Floating point, on/off control damper actuators shall be electronic direct-coupled type, which require no crankarm and linkage and be capable of direct mounting to a shaft from 1/4" to 5/8". Shafts up to 3/4" diameter can be accommodate with an accessory clamp. Actuators shall have Brushless DC motor technology and be protected from overload at all angles of rotation. Actuators shall have reversing switch and manual override on the cover. If required, actuator will be provided with screw terminal strip for electrical connections (LMCB24-3-T). If required, actuators shall be provided with one adjustable SPDT auxiliary switch. Actuators with auxiliary switches must be constructed to meet the requirements for double insulation so an electrical ground is not required to meet agency listings. Run time shall be constant and independent of torque. Actuators shall be cULus listed, have a 5-year warranty, and be manufactured under ISO 9001 International Quality Control Standards. Actuators shall be as manufactured by Belimo.

### Wiring Diagrams

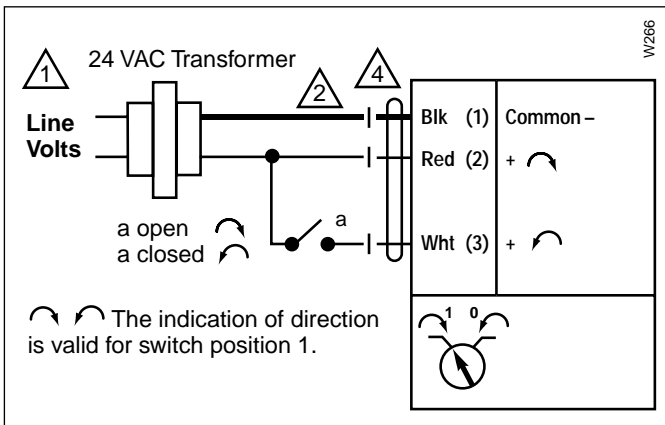

**On/Off**

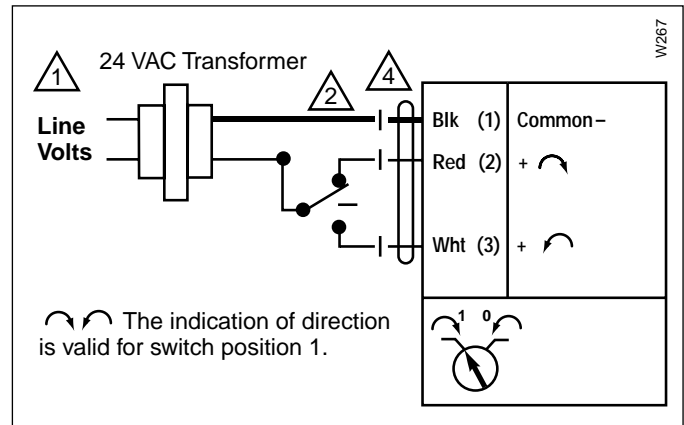

**Floating Point or On/Off control**

### Notes:

- 1 Provide overload protection and disconnect as required.
- 2 Actuators may also be powered by 24 VDC.
- 4 Meets cULus requirements without the need of an electrical ground connection.

<b>Table of Contents</b>	<b>Page</b>
<b>General Mounting</b>	
□ Standard .....	266
□ Reversible Clamp .....	267
□ Linear .....	268
□ Rotary .....	269
□ Retrofit Brackets .....	271
<b>Operation</b>	
□ Electrical .....	272
□ Mechanical .....	273
<b>Wiring</b>	
□ General .....	274
□ Accessories .....	275
<b>Startup and Checkout</b> .....	278

### General Information

#### Preliminary Steps

1. Belimo actuators with NEMA 1 or NEMA 2 ratings should be mounted indoors in a dry, relatively clean environment free from corrosive fumes. If the actuator is mounted outdoors, a protective enclosure must be used to shield the actuator.
2. For new construction work, **order dampers with extended shafts**. Instruct the installing contractor to allow space for mounting the Belimo actuator on the shaft.

For replacement of existing gear train actuators, there are two options:

- A. From a performance standpoint, it is best to mount the actuator directly onto the damper shaft.
- B. If the damper shaft is not accessible, mount the non-spring return actuator with a ZG-NMA or ZG-GMA crankarm kit, and a mounting bracket (ZG-100, ZG-101, ZG-103, ZG-104)

### Determining Torque Loading and Actuator Sizing

Damper torque loadings, used in selecting the correct size actuator, should be provided by the damper manufacturer. If this information is not available, the following general selection guidelines can be used.

Damper Type	Torque Loading
Opposed blade, without edge seals, for non-tight close-off applications	3 in-lb/sq. ft.
Parallel blade, without edge seals, for non-tight close-off applications	4 in-lb/sq. ft.
Opposed blade, with edge seals, for tight close-off applications	5 in-lb/sq. ft.
Parallel blade, with edge seals, for tight close-off applications	7 in-lb/sq. ft.

The above torque loadings will work for most applications under 2 in. w.g. static pressure or 1000 FPM face velocity. For applications between this criteria and 3 in. w.g. or 2500 FPM, the torque loading should be increased by a multiplier of 1.5. If the application calls for higher criteria up to 4 in. w.g. or 3000 FPM, use a multiplier of 2.0.

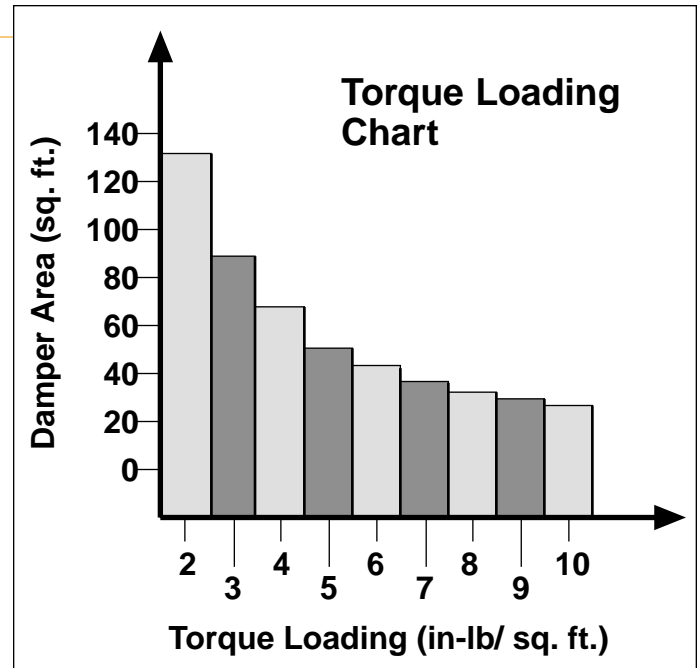

### Multiple Actuator Mounting

If more torque is required than one GM can provide, GM24B, GMB24-SR or GMX24-MFT may be installed on the same shaft.

# Installation Instructions

## Quick-Mount Visual Instructions for Mechanical Installation

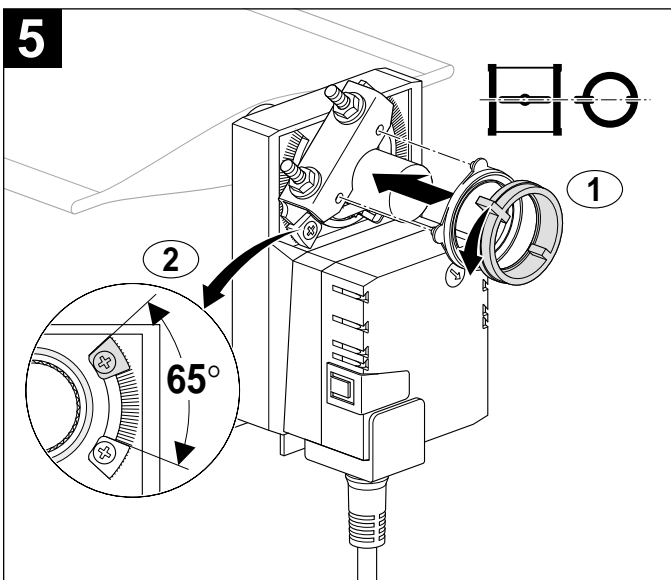
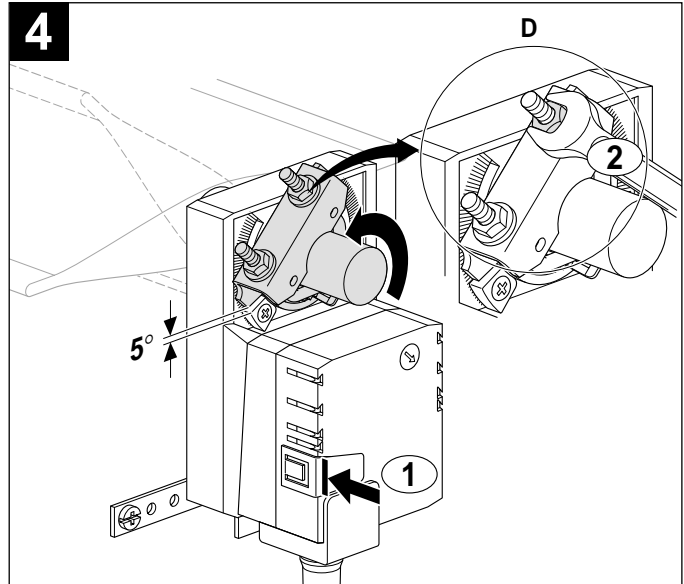
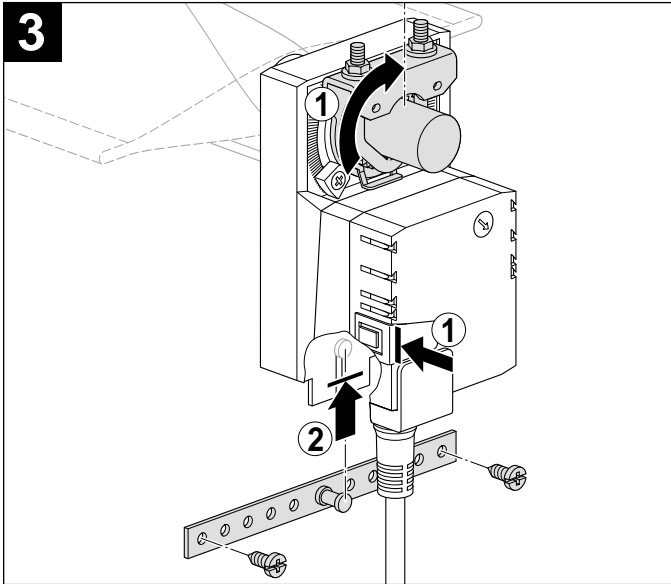
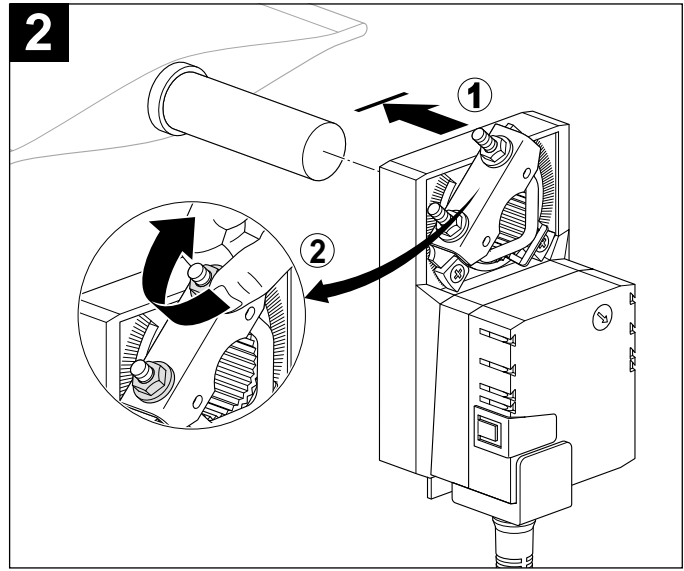
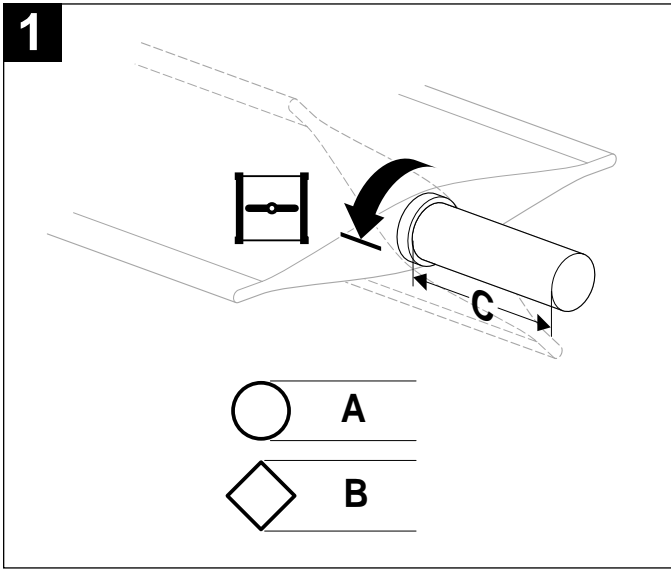

See next page for standard mounting instructions.

	A*	B	C**	D
LM	1/4" to 3/4"	5/16" to 3/4"	1.5"	4 to 5 ft-lb
NM	1/2" to 1.05"	2/5" to 1.05"	1.5"	6 to 7 ft-lb
AM	1/2" to 1.05"	2/5" to 1.05"	1.5"	6 to 7 ft-lb
GM	1/2" to 1.05"	2/5" to 1.05"	1.5"	6 to 7 ft-lb

\*LM standard clamp has max 5/8" diameter. Accessory clamp K-LM20 can be mounted for sizes up to 3/4" diameter.  
 NM, AM and GM clamps have an insert that self-centers on the following diameter shafts: 1/2" (default), 3/4" and 1.05".

\*\*Shorter with reversible clamp for NM, AM, and GM

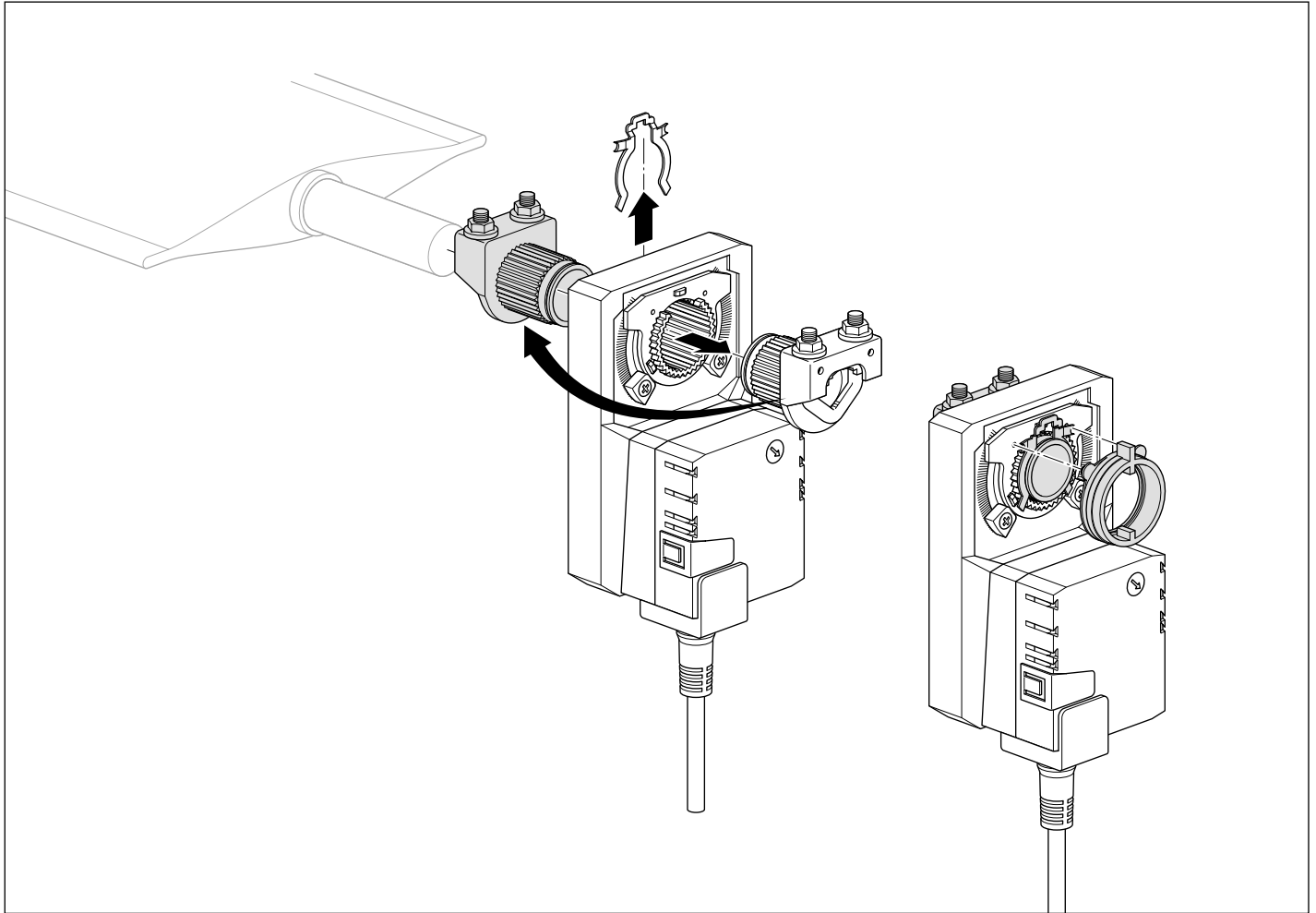

### Standard Mounting

1. Turn the damper shaft until the blades are fully closed.
  2. ① Slip the actuator's universal clamp over the damper shaft. Make sure that the duct and the controls on the cover are accessible. Place the actuator in the desired mounting position.  
② Hand tighten the two nuts on the actuators universal clamp.
  3. ① Disengage the actuator gear train by pressing the manual override button and rotate the clamp until centered.  
② Slide the anti-rotation strap up under the actuator so it engages the actuator at the center cutout. Bend the bracket as needed to support the rear of the actuator. Secure to ductwork with self-tapping screws (No. 8 recommended).
  4. ① Loosen the nuts on the universal clamp. Press the manual override button and rotate the clamp to about 5° from the closed position (1/16 to 1/8" between stop and clamp).  
② Tighten the two nuts on the universal clamp with a 10 mm wrench (see table for required torque).
  5. ① Snap on the reflective position indicator.  
② Adjust end-stops, if required.
  6. Mount actuators indoors. If mounted outdoors, use approved protective enclosure.
- The damper is now fully closed but the actuator is 5° from fully closed. This is called "pre-loading" the actuator. When the actuator is powered and sent to the closed position: it will put its full torque on the shaft compressing the edge and blade seals. This ensures that the damper will meet its leakage rating. The actuator is electronically protected from overload and will not be damaged.

### Testing the Installation Without Power

1. Disengage the gear train with the manual override button and move the shaft from closed to open to closed. Ensure that there is no binding and that the damper goes fully open and closes with 5° of actuator stroke left.
2. Correct any problems and retest.