

FSAF120A-S

On/Off, Spring Return, AC 120 V, Auxiliary Switch



Technical Data	
Power Supply	120 VAC, ±10%, 50/60 Hz
Power consumption in operation	30 VA
Power consumption in rest position	7.5 W, 12 VA (50 Hz 20 VA), End stop 47 VA, 0.5 A slow blow fuse *
Shaft Diameter	1/2...1.05" round, centers on 3/4" with insert, 1.05" without insert
Electrical Connection	18 GA appliance cable, 3 ft [1 m], with 1/2" conduit connector
Overload Protection	electronic throughout 0...95° rotation
Electrical Protection	grounded enclosure, 120 V
Angle of rotation	95°
Torque motor	180 in-lb [20 Nm]
Direction of motion motor	selectable by ccw/cw mounting
Direction of motion fail-safe	reversible with cw/ccw mounting
Position indication	Mechanical
Running Time (Motor)	25 s
Running time fail-safe	<15 s
Ambient humidity	max. 95% r.H., non-condensing
Ambient temperature	32...122°F [0...50°C]
Storage temperature	-40...176°F [-40...80°C]
Degree of Protection	IP40, NEMA 1
Housing material	galvanized steel
Gears	steel, permanently lubricated
Agency Listing	cULus listed to UL60730-1A:02; UL 60730-2-14:02 and CAN/CSA-E60730-1:02; Listed to UL 2043 - suitable for use in air plenums per Section 300.22(c) of the NEC and Section 602.2 of the IMC
Noise level, motor	70 dB(A)
Noise level, fail-safe	73 dB(A)
Servicing	maintenance-free
Quality Standard	ISO 9001, RoHS (EU-Directive 2011/65/EU)
Weight	7.2 lb [3.2 kg]
Auxiliary switch	2 x SPST, 6 A resistive (2.5 A inductive) @ AC 250 V, one set at 5°, one set at 85°

† UL File XAPX.E108966

Fire & Smoke, 180 in-lb @ 350°F for 30 min., 25 s drive, 15 s spring

Application

The FSAF_A-S Auxiliary Switch actuators provide true spring-return operation for reliable fail-safe application and positive close-off on UL555S dampers. The spring-return system provides constant torque to the damper with and without power applied to the actuator. The FSAF_A series provides 95° of rotation and is provided with a graduated position indicator showing 0...95°. Two SPST auxiliary switches provide means of closed and open damper position indication.

Operation

The FSAF_A series actuators are mounted to the damper axle shaft or jackshaft (1/2" to 1.05") via a cold-weld clamp. Teeth in the clamp and V-bolt dig into the metal of both solid and hollow shafts maintaining a perfect connection. The specially designed clamp will not crush hollow shafts. The bottom end of the actuator is held by an anti-rotation strap or by a stud provided by the damper manufacturer. The actuator is mounted in its fail safe position with the damper blade(s) closed. Upon applying power, the actuator drives the damper to the open position. The internal spring is tensioned at the same time. If the power supply is interrupted, the spring moves the damper back to its fail-safe position.

Note on linkage kits. The correct leg kit for the FSAF_A series is the older ZG-AF US as the actuator has a classic AF frame. However, the spline is the new generation type and the crank arm required is the KH-AFB.

Dimensions (Inches[mm])

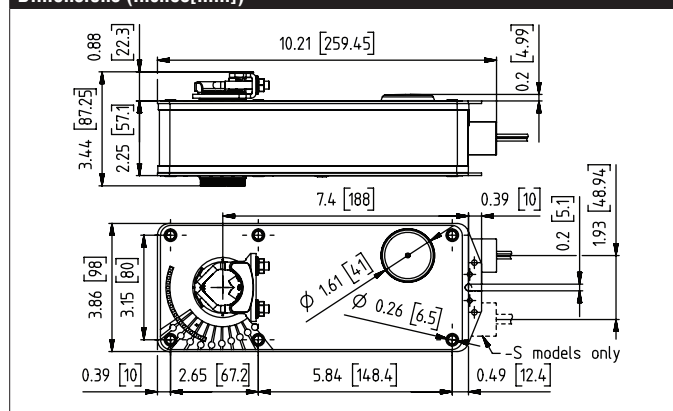

Safety Notes

* Neither UL nor Belimo require local over-current protection. The FSAF_A actuators draw higher peak current when driving against any type of stop. After 10 seconds current drops to the lower holding level. If used, this requires the value of a local fuse or breaker to be increased to avoid nuisance opening or tripping. A 2 A slow blow should be used for AC 24 V. A 0.5 A slow blow should be used for AC 120 V. A 0.25 A slow blow should be used for AC 230 V and a 0.3 A slow blow for AC 208 V.

Accessories	
AF-P	Anti-rotation bracket AF/NF.
SH8	Push rod for KG6 & KG8 ball joints (36" L, 5/16" diameter).
TOOL-06	8 mm and 10 mm wrench.
ZG-100	Univ. right angle bracket 17"x11-1/8"x6" (HxWxbase).
ZG-101	Univ. right angle bracket 13x11x7-7/16" (HxWxbase).
ZG-102	Dual actuator mounting bracket.
ZS-100	Weather shield - galvaneal 13x8x6" (LxWxD).
ZS-150	Weather shield - PC w/ foam seal 16x8-3/8x4" (LxWxD).
ZS-260	Explosion proof housing.
ZS-300	NEMA 4X, 304 stainless steel enclosure.
ZG-AFA108	FSAF..A series crankarm adaptor kit with ZG-108
ZG-AFA	Leg kit for FSAF_A series actuators
BAE165 US	165° F electric thermal sensor, SPST, normally closed.
S2A-F US	Auxiliary switch, 2x SPDT, 3A (0.5A inductive) @250 VAC max.

Typical Specification

All smoke and combination fire and smoke dampers shall be provided with Belimo FSTF, FSLF, FSNF, or FSAF actuators. All substitutions must be approved before submission of bid. Damper and actuator shall have UL 555S Listing for 250°F and/or 350°F. Actuator shall have been tested to UL 2043 per requirements of IMC 602.2 and NEC 300.22 (c). Where position indication is required -S models with auxiliary switches or damper blade switches will be provided per code requirements.

Wiring Diagrams

- Provide overload protection and disconnect as required.
- Actuators may be powered in parallel. Power consumption must be observed.
- S4 makes to S6 when actuator is powered open.
- Auxiliary switches are for end position indication or interlock control.
- Double insulated.
- Ground present on some models.

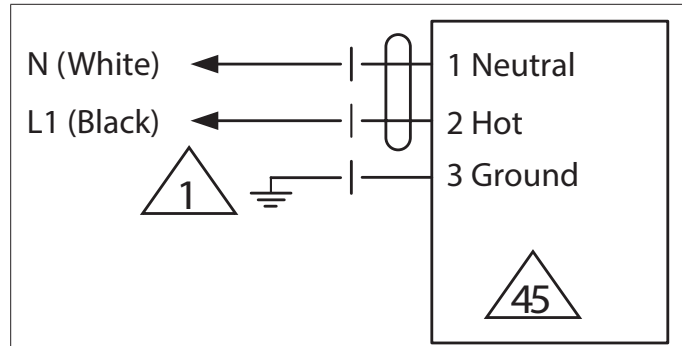

120 VAC

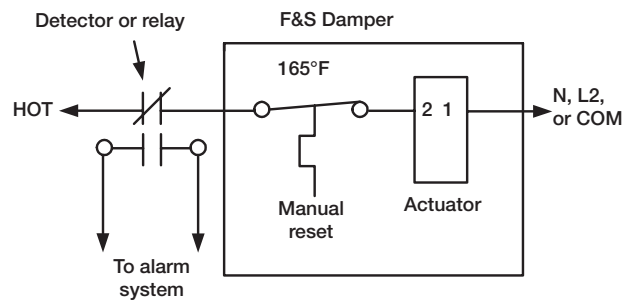

Typical containment damper control wiring

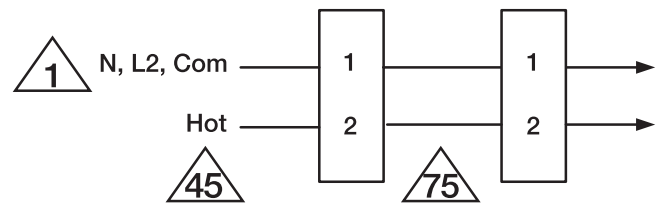

Parallel Actuator Wiring

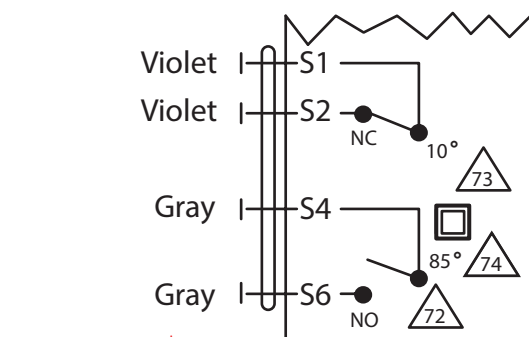

Auxiliary Switch Wiring