

# B225HT1160 Technical Data Sheet

## Stainless Steel Ball and Stem



### Technical Data

Fluid	high temperature hot water/low pressure steam, up to 60% glycol
Flow characteristic	A-port equal percentage
Controllable flow range	75°
Valve Size [mm]	1" [25]
Pipe connection	NPT female ends
Housing	Nickel-plated brass (DZR) P-CuZn35Pb2
Ball	stainless steel
Stem	stainless steel
Stem seal	Viton O-ring
Seat	ETFE
O-ring	EPDM (lubricated)
Characterised disc	ETFE
Body Pressure Rating	600 psi
Maximum Inlet Pressure (Steam)	15 psi
Max Differential Pressure (Steam)	15 psi
Close-off pressure $\Delta$ ps	200 psi
Cv	11.6
Weight	1.76 lb [0.80 kg]
Fluid Temp Range (water)	60...266°F [16...130°C]
Leakage rate	0%
Maintenance	maintenance-free

### Flow/Mounting Details

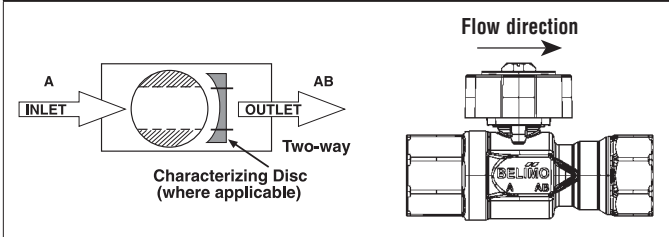

### Application

This valve is typically used in air handling units on heating or cooling coils, and fan coil unit heating or cooling coils. Some other common applications include unit ventilators, VAV box re-heat coils and bypass loops. This valve is suitable for use in a hydronic system with variable flow.

This valve is designed to fit in compact areas where on/off, floating point and modulating control is required using 24 VAC.

### Suitable Actuators

	Non-Spring	Spring
B225HT1160	LRB(X)	LF

### Dimensions (Inches [mm])

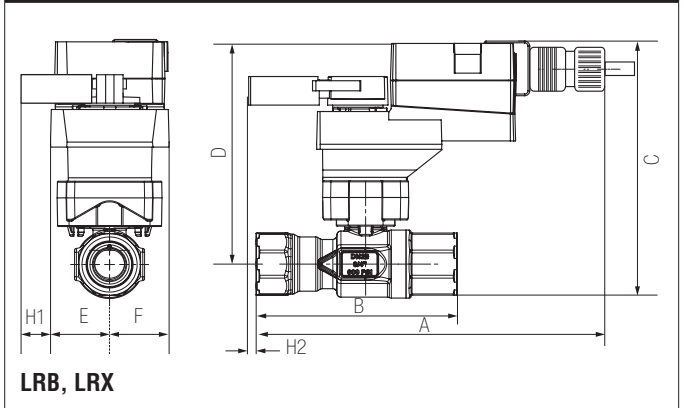

A	B	C	D	E	F	H1	H2
8.6" [218]	5.2" [131]	6.9" [175]	6.4" [162]	1.3" [33]		1.2" [30]	0.6" [15]

### Safety Notes

**WARNING:** For Belimo products sold in California: these products do or may contain chemicals which are known to the State of California to cause cancer and or birth defects or other reproductive harms. For more information see [www.p65warnings.ca.gov](http://www.p65warnings.ca.gov).

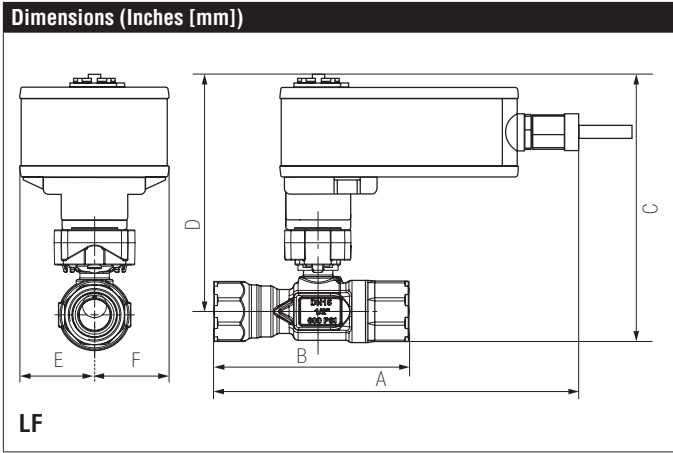

A	B	C	D	E	F
9.5" [241]	5.2" [131]	7.7" [196]	6.9" [174]	1.9" [48]	

# LF24-SR-S US, Valve Actuator Technical Data Sheet

Modulating, Spring Return, AC 24 V for DC 2...10 V or 4...20 mA Control Signal



5-year warranty



## Technical Data

Power Supply	24 VAC, ±20%, 50/60 Hz, 24 VDC, ±10%
Power consumption in operation	2.5 W
Power consumption in rest position	1 W
Transformer sizing	5 VA (class 2 power source)
Electrical Connection	(2) 18 GA appliance cables with 1/2" conduit connectors, 3 ft [1 m],
Overload Protection	electronic throughout 0...95° rotation
Operating Range	DC 2...10 V, 4...20 mA w/ ZG-R01 (500 Ω, 1/4 W resistor)
Input Impedance	100 kΩ for DC 2...10 V (0.1 mA), 500 Ω for 4...20 mA
Position Feedback	DC 2...10 V, Max. 0.7 mA
Angle of rotation	90°
Direction of rotation motor	reversible with built-in switch
Direction of motion fail-safe	reversible with cw/ccw mounting
Position indication	Mechanical
Running Time (Motor)	150 s constant, independent of load
Running time fail-safe	<25 s @ -4...122°F [-20...50°C], <60 s @ -22°F [-30°C]
Ambient humidity	max. 95% r.H., non-condensing
Ambient temperature	-22...122°F [-30...50°C]
Storage temperature	-40...176°F [-40...80°C]
Degree of Protection	IP54, NEMA 2
Agency Listing	cULus acc. To UL 873 and CAN/CSA C22.2 No. 24-93
Noise level, motor	50 dB(A)
Noise level, fail-safe	62 dB(A)
Maintenance	maintenance-free
Quality Standard	ISO 9001
Weight	3.2 lbs (1.45 kg.)
Auxiliary switch	1 x SPDT, 3 A resistive (0.5 A inductive) @ AC 250 V, adjustable 0...95°

†Rated Impulse Voltage 800V, Type of action 1.AA, Control Pollution Degree 3

## Safety Notes

**WARNING:** For Belimo products sold in California: these products do or may contain chemicals which are known to the State of California to cause cancer and or birth defects or other reproductive harms. For more information see [www.p65warnings.ca.gov](http://www.p65warnings.ca.gov).

**Wiring Diagrams**

**✂ INSTALLATION NOTES**

- A Actuators with appliance cables are numbered.
- 1 Provide overload protection and disconnect as required.
- 3 Actuators may also be powered by 24 VDC.
- 5 Only connect common to negative (-) leg of control circuits.
- 7 A 500 Ω resistor (ZG-R01) converts the 4 to 20 mA control signal to 2 to 10 VDC.
- 11 Actuators may be connected in parallel if not mechanically linked. Power consumption and input impedance must be observed.
- 44 One built-in auxiliary switch (1x SPDT), for end position indication, interlock control, fan startup, etc.
- ⚡ Apply only AC line voltage or only UL-Class 2 voltage to the terminals of auxiliary switches. Mixed or combined operation of line voltage/safety extra low voltage is not allowed.

◆ Meets cULus requirements without the need of an electrical ground connection.

! **WARNING! LIVE ELECTRICAL COMPONENTS!**  
 During installation, testing, servicing and troubleshooting of this product, it may be necessary to work with live electrical components. Have a qualified licensed electrician or other individual who has been properly trained in handling live electrical components perform these tasks. Failure to follow all electrical safety precautions when exposed to live electrical components could result in death or serious injury.

