

# Beckett

## GENISYS® 7565 & 7585 120v Advanced Burner Controls



### DESCRIPTION / APPLICATIONS

The Beckett GeniSys® Advanced Burner Control is a 120 Vac primary safety control for residential and light commercial oil burners used in boiler, furnace, and water heater applications having firing rates less than 20 GPH.

The GeniSys is used with a suitable cad cell flame sensor to control the oil burner motor, igniter, and optional solenoid valve. It has 24 Vac thermostat terminals compatible with both mechanical and many power stealing thermostats. It can also provide interrupted or intermittent duty ignition.

# Beckett®

# Table of Contents

Content	Page
Features	2
Definitions	2
MyTechnician®	2
Installation/Operation/Maintenance	4
Startup / Checkout	6
Sequence of Operation	7
Maintenance	9
Appendix A - Typical Boiler Wiring	10
Appendix B - Typical Furnace Wiring	10
Appendix C - Typical Thermostat Wiring	11
Appendix D - Typical Air Input Wiring	11

Note: All features in this document apply to both the 7565 and the 7585 unless otherwise noted.

## Features

- Diagnostics and programming through the myTechnician® app
- Last 50 cycles and last 15 faults
- Compatible with burners running #2 Fuel oil, up to 100% biodiesel, and up to 100% renewable diesel.
- Interrupted or Intermittent Duty Ignition
- Limited Recycle
- Limited Reset
- 8 Status Lights
- Valve-On Delay (also known as “Pre-Purge”)
- Motor-Off Delay (also known as “Post-Purge”)
- Blocked Vent and/or Combustion Air Inputs
- Technician Pump Priming Mode
- Disable Function
- Water Resistant Case
- Encapsulated electronics (7585 only)
- Thermostat “C” terminal (for enhanced compatibility)

## Definitions

- Intermittent - ignition remains on during the entire cycle
- Interrupted - ignition turns off after flame is proven
- Recycle - if flame is lost after Trial for Ignition (TFI), then burner resets for 60 seconds and retries automatically if it has not exceeded the allowable number of retries.
- Relight - if flame is lost after Trial for Ignition (TFI), then ignition automatically turns back on

- Blocked Vent (BV) - The control will not start a heat cycle unless the switch is closed. The control will Recycle if the switch opens after a successful ignition trial period. It must be closed during burner cycles. Use this setting with a blocked vent switch.
- Combustion Air Proving (CAP) - The control will not start a heat cycle unless the switch is open. The control will Recycle if the switch does not close after the motor is turned on and remain closed throughout the rest of the heat cycle. Use this setting with a power venter.



For displaying status information, programming control timings, and viewing the history log, the 7565 and 7585 are compatible with the myTechnician® app available from your device’s app store.



myTechnician® App for Android Devices



myTechnician® App for Apple Devices

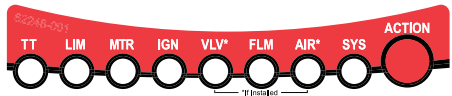

Table 1 - Status Lights

	Green	Red	Yellow
TT	On = TT Closed	n/a	n/a
LIM	On = Limit closed	n/a	n/a
MTR	On = Running	On = Fault	n/a
IGN	On = Running	On = Fault	n/a
VLV *	On = Running	On = Fault	n/a
FLM	On = Flame Present	On = no flame detected	On = Flame out of sequence or cad cell shorted
AIR *	On = All installed switches ok	On = Blocked flue	On = Inlet air fault
SYS	On = Power	On = Hard Lockout Flashing = Soft Lockout	On = Pump prime Flashing = Recycle

Asterisk = If installed

Figure 1 – Getting to know the control

## Top and Front Face Connections

Status Lights  
(See Table 1)



- Thermostat Red (Tr)
- Thermostat White (Tw)
- Thermostat COMMON (Tc)\*
- Air switch input (24VAC)\*
- Air switch input (24VAC)\*

Asterisk = If installed  
NOTE: All front connections are low voltage, 24 Vac connections



ACTION Button  
(See Table 2)

## Under Side Connections

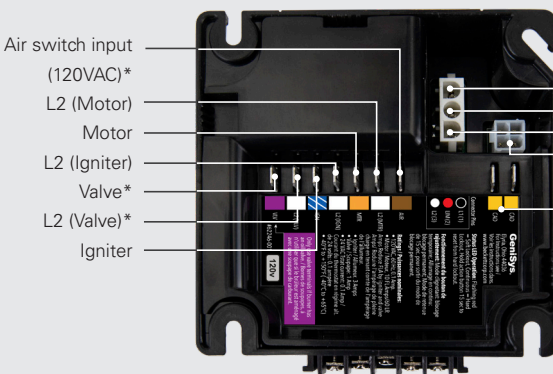

- Power Connector:
- L1 (black)
- Limit (red)
- L2 (white)
- Reserved for Future Use

CAD Cell  
CAD Cell

Caution: if replacing a non-Beckett control, these colors may vary.  
Asterisk = If installed



**Do Not Use This Control in an Application that is Not Within the Ratings Listed in This Section. Improper Control Operation May Result.**

## Installation/Operation/ Maintenance



**Professional Service Required**



***Incorrect installation or misuse of this control could result in severe personal injury, death, or substantial property damage from heavy smoke, explosion or fire.***

### Electrical Ratings

#### Power:

- Voltage: 120 Vac nominal (102 to 132 Vac)
  - Current: 100 mA nominal (150 mA max at 132 Vac)\*
  - Frequency: 60 Hz
- \*measured when the motor, valve, and igniter are all de-energized*

#### Inputs:

- Thermostat Anticipator Current: 0.1 A nominal
- Thermostat Voltage: 24 Vac nominal
- Combustion Air/Blocked Vent (Front side): 10mA @ 24Vac min (Underside): 1.9mA @ 120Vac min

#### Outputs:

- Motor: 120 Vac, 10 max full load amps (FLA), 60 max locked rotor amps (LRA)
- \*Note: Reduce motor FLA rating by igniter and valve currents*
- Igniter: 120 Vac, 3 A max
  - Solenoid Valve: 120 Vac, 1 A max

#### Environmental Ratings:

- Storage and Operating Ambient Temperature: -40°F to +150°F (-40°C to +65°C)
- Moisture: 5 to 95% RH, non-condensing and non-crystallizing
- 7585 is rated for condensing environments

#### Approvals:

- Underwriters Laboratory Recognition per UL 60730-1 / 60730-2-5, CSA E60730-1 / C22.2 NO. 60730-2-5



**Do Not Use This Control Above 19.9 GPH**

***Most codes and standards require additional safeguards and features for oil burner inputs above 19.9 gph. Consult the appliance manufacturer's instructions for control selection.***



**Frozen Plumbing and Water Damage Hazard**

***If the residence is unattended in severely cold weather, burner primary control safety lockout, heating system component failures, power outages or other electrical system failures could result in frozen plumbing and water damage in a matter of hours. For protection, take preventive actions such as having a security system installed that operates during power outages, senses low temperature and initiates an effective action. Consult with your heating contractor or a home security agency.***

**WARNING**

**Fire or Explosion Hazard**



*Can cause severe injury, death, or property damage.*

- The control can malfunction if it gets wet, leading to accumulation of oil or explosive oil vapors.
- Never install where water can flood, drip or condense on the control.
- Never use a control that has been wet - replace it.

**WARNING**

**Electrical Shock Hazard**



*Electrical shock can cause severe personal injury or death.*

- Disconnect ALL electrical power to the appliance/burner circuit before installing or servicing this control.
- Provide ground wiring to the appliance, burner and metal control mounting box.
- Perform all wiring in compliance with the National Electrical Code ANSI/NFPA 70 (Canada CSA C22.1).

**WARNING**

**Explosion, Fire, Scald, and Burn Hazard**



*All heating appliances must have HIGH LIMIT protection to interrupt electrical power and shutdown the burner if operating or safety controls fail and cause a runaway condition.*

- Follow the appliance manufacturer's wiring diagrams and note all required safety controls.
- Typical safety controls include but not limited to high temperature or pressure limits, low water cutoffs, pressure relief valves and blocked flue sensing switches.
- Verify all limit and safety controls are installed and functioning correctly, as specified by the manufacturer, applicable safety standards, codes and all authorities having jurisdiction.
- Ensure that the appliance is free of oil and oil vapor before starting or resetting the burner.

**CAUTION**

**Incorrect Wiring Will Result in Improper Control Operation**

- The control wiring label colors may not match the wire colors of the burner or other manufacturers' controls.
- The control should be wired according to the appliance manufacturer's instructions.

**Mounting:**

- Mount the control on a 4" x 4" junction box on the burner, or inside the appliance cabinet. In replacement applications, mount the new control in the same location as the old control. In some replacement applications, it may be necessary to rotate the control on the 4" x 4" box for best fit.
- Mounting orientation: any orientation is acceptable, except upside down or with the terminal block (front) facing up.

**Wiring:**

- Make sure all appliance wiring complies with all local codes and ordinances.
- Make connections to the control's terminals as shown in Figures 2 through 9. Refer to the label on the underside of the control for wiring details.

**NOTICE**

**Some Thermostats Are Polarity Sensitive. Reversed polarity could cause erratic cycling of the burner control.**

- Connect the red wire from the R<sub>H</sub> or R terminal on the thermostat to the T<sub>R</sub> terminal on the control.
- Connect the white wire from the W terminal on the thermostat to the T<sub>w</sub> terminal on the control.
- Some thermostats may require connection to the T<sub>c</sub> terminal on the control for proper operation (see Appendix C).

# Startup / Checkout



## WARNING

### Fire Hazard



**Reset and Service by Qualified Technician only.**



## WARNING

### Carbon Monoxide Hazard

**Do not block combustion air inlet. Failure to provide adequate air supply could seriously affect the burner performance and result in damage to the equipment and emission of poisonous carbon monoxide gas.**

If the burner or control fails any of the following tests, recheck control wiring. If the burner or control still fails any tests, replace the control.

## Starting the System

1. Open the shut-off valves in the supply line from the oil tank.
2. Close the disconnect switch to supply power to the burner.
3. Adjust the thermostat or boiler control to call for heat.  
*- If the pump has not been primed, refer to "Priming the Pump" in the "Operation" section of this manual.*
4. Monitor burner operation to ensure that the burner ignites.
5. End the call for heat. Verify that the burner turns off before leaving the installation site.

## Check Safety Features

- Safe Start Check
  1. Place a jumper across the cad cell terminals.
  2. Refer to the steps for "Starting the System" and have the system call for heat.

3. Burner must not start. Verify that the SYS light is green, FLM light is yellow, and that the control remains in Standby mode.
4. End the call for heat and remove the cad cell jumper.

- Simulate Flame Failure and Ignition Failure

1. Refer to the steps for "Starting the System" and have the system call for heat.
2. After flame is established and the burner igniter turns off, close the hand valve in the oil supply line.
3. At flame loss, the control will enter Recycle mode. Verify that the SYS light is flashing yellow. The control will remain in Recycle for 60 seconds.
4. After the 60 second recycle period, the control will try to restart the system.
5. After the 15 second lockout time, the control will lock out the burner and the SYS light will flash red. Verify that the burner motor and igniter are off and that the burner oil solenoid valve (if used) is not energized.
6. Open the hand valve in the oil line.
7. Click the ACTION button and verify that the SYS light shows green and the burner lights.
8. End the call for heat.

- Before leaving the installation, verify that all thermostat and boiler/furnace control wiring is correct and that the burner and safety features of the appliance operate properly. Consult heating appliance manual for directions.

# Sequence of Operation

## Burner States

- Standby:** The burner is idle, waiting for a call for heat.
- Validate Air:** once the motor turns on and if configured, the control will prove air before pre-purge. This feature requires either a pressure switch or a spill switch.
- Valve-On Delay:** Pre-Purge, the igniter and motor are on while the control delays turning on the oil solenoid valve for the programmed time. This feature requires either a Beckett Clean-Cut pump or an external valve.
- Trial For Ignition (TFI):** If used, the oil solenoid valve is energized. A flame should be established within the factory set trial for ignition time ("lockout time").
- Ignition Carryover:** Once flame is established, the igniter remains on for the configured carryover time delay to ensure flame stability.
- Run:** The flame is sustained until the call for heat is satisfied. The burner is then sent to Motor-Off Delay, if applicable, or it is shut down and sent to Standby.
- Motor-Off Delay:** Post-Purge, if applicable, the oil solenoid valve is turned off and the control delays turning the motor off for the set motor-off delay time before the control returns to standby. This feature requires either a Beckett Clean-cut pump or an external valve.
- Recycle:** If the flame is lost or if the pressure or spill switch (if used) open while the burner is firing, the control shuts down the burner, enters a 60 second recycle delay, and repeats the ignition sequence. The control will continue to Recycle each time the flame is lost, until it reaches the configured number 3 max of retries. The control will then go into Lockout instead of recycle. This feature prevents excessive accumulation of oil in the appliance firing chamber.

Figure 2 - Sequence of Operation

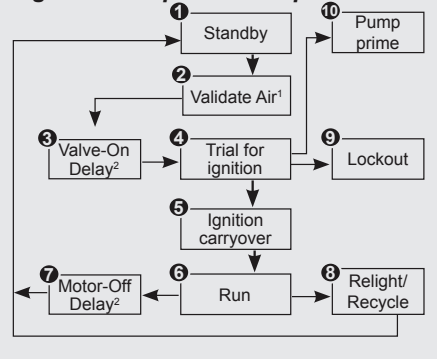

1 = only if air switch is installed  
2 = only if valve installed

- Lockout:** The control has shut down for one of the following safety reasons:
  - The trial for ignition (lockout) time expired without flame being established.
  - The cad cell detected flame at the end of the Valve On Delay state.
  - Flame is lost while the burner is firing and the pre-set time allotment is expired. See "Recycle" (*Item 7*).

To reset the control from (soft) lockout click the button 1-second.

**NOTE:** A recurrence of the above failure modes or a failed welded relay check could cause the control to enter a **Hard Lockout** state that must be reset only by a qualified service technician.

To reset from Hard Lockout, hold the ACTION button for 15 seconds until the SYS light briefly turns from red to yellow.

## ACTION Button Operation

- Pump Prime:** The igniter and motor are on with the oil solenoid valve energized for 4 minutes. During Pump Prime mode, the cad cell is disregarded, allowing the technician to prime the pump without having to jumper the cad cell.

**Table 2** explains what action the control will take when the button is pressed for different lengths of time during the various burner operating states.

### Priming the Pump

1. Prepare the burner for priming by attaching a clear plastic hose over the bleed port fitting and fully opening the pump bleed port. Use a suitable container to collect purged oil.
2. Initiate a call for heat.

3. After the burner starts, press and hold the ACTION button for 15 seconds until the yellow light turns on. This indicates that the button has been held long enough.
4. Release the ACTION button. The yellow light will turn off and the burner will start up again.
5. At burner start up, click the ACTION button while the igniter is still on. This will transition the control to a dedicated Pump Prime mode, during which the motor, igniter, and valve are powered for four minutes. The SYS light will be solid yellow for the duration of Pump Prime mode.
6. Bleed the pump until all froth and bubbles are purged. If desired, terminate the call for heat or hold the ACTION button for at least one second to exit Pump Prime mode and return to Standby.
7. At the end of 4 minutes, SYS light will turn from yellow to green and the control will automatically return to standby mode.
8. If prime is not established during the four minute pump prime mode, return to step 5 to re-enter Pump Prime mode. Repeat steps 5 through 7 until the pump is fully primed and the oil is free of bubbles.
9. Terminate the call for heat, and the control will resume normal operation.









**WARNING**

**Hot Gas Puff-Back and Heavy Smoke Hazard**

*Failure to bleed the pump properly could result in unstable combustion, hot gas puff-back and heavy smoke.*

- Do not allow oil to spray into a hot combustion chamber while bleeding air from the pump.
- Install a gauge in the nozzle discharge port tubing or fully open the pump bleed valve to prevent oil spray from accumulating in the combustion chamber during the air bleed procedure.
- Ensure that all bubbles and froth are purged from the oil supply system before tightening the pump bleed valve.
- Ensure that the appliance is free of oil and oil vapor before starting or resetting the burner.

### Table 2 - ACTION Button Operation

Intended Action	Press the ACTION button	Results
To exit from (soft) Lockout	 1 SECOND TAP	Resets the Control
To exit from (hard) Lockout	 15+ SECONDS	Resets the Control
To enter Pump Prime mode (2 steps)	 15+ SECONDS	Step 1 - enables pump prime on next call-for-heat.
	 1 SECOND TAP	Step 2 - starts pump prime when pressed during valve-on delay, trial for ignition, or ignition carry over.
To pause burner operation	 1+ SECONDS	Exits current state and enters Stand-by, then keeps burner off while the button is held
To program settings or view history	 1 SECOND TAP	Connects to the myTechician app when prompted.

## Resetting From Restricted or Hard Lockout



### WARNING

### Fire, Smoke & Fuel Leak Hazard



*Before starting or resetting the control from restricted lockout state, troubleshoot the heating system for the root cause(s) of the lockout.*

- Make necessary repairs or adjustment to ensure a safe start condition.
  - Ensure that the appliance is free of oil and oil vapors before starting or resetting the burner.
- 
- If the control continues to lock out without a satisfied call for heat, or fails the motor relay check, the control enters Hard (restricted) Lockout in order to limit accumulation of unburned oil in the combustion chamber.
  - To reset, hold the ACTION button down for 15 seconds until the SYS light is no longer red.
  - Always verify the control functions according to all specifications before leaving the installation site.
  - Replace the control if it does not operate as specified.

## Disable Function

- Any time the burner is running, press and hold the ACTION button to disable the burner. The burner will remain off as long as the button is held.

## Maintenance

Oil heating systems require annual service performed by a qualified, professional service agency. The 7565 primary control should be inspected during this service routine according to the following checklist:

- NOTE: The 7565 control has no serviceable internal parts. Do not attempt to remove cover.
- Inspect the exterior of the control. Replace the control if there is any sign of impact damage, water or corrosion.
- Use a multimeter to test the line voltage at control L1 and L2. It should be 102 - 132 Vac.
- Inspect all external wiring for secure connections and verify insulation integrity.
- Verify the control lockout and operation sequence (Refer to “Check Safety Features” of the Startup/Checkout section).
- Observe a full operating cycle to prove the sequence and timings are correct.
- Replace any control that does not meet listed specifications with an equivalent replacement unit.

## Appendix A - Typical Boiler Wiring

**Figure 3 – 7565 (for replacement of R8184G)**  
No valve-on delay, no motor-off delay.

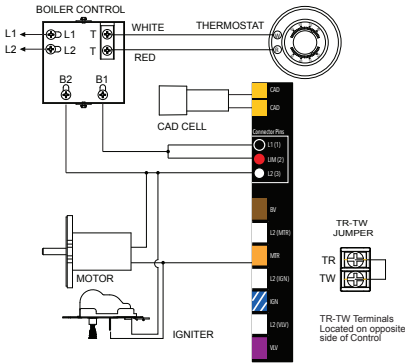

**Figure 4 – 7565 (for replacement of R7184B)**  
Valve-on delay only (no motor-off delay)

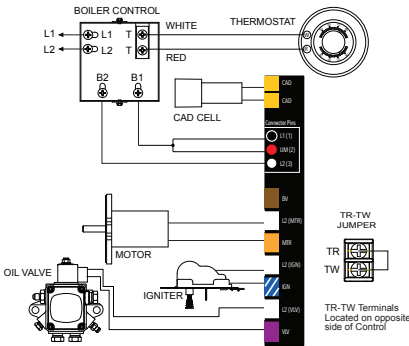

**Figure 5 – 7565 (for replacement of R7184P)**  
Interrupted ignition, valve-on and motor-off delays

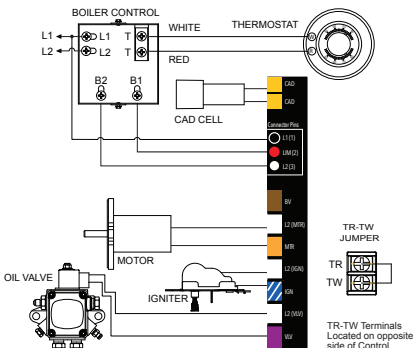

**NOTE:** To disable motor-off delay on a 7565 control, jumper L1 and limit together and wire as shown in Fig. 4 or just program it with a zero second motor-off delay

## Appendix - B Typical Furnace Wiring

**Figure 6 – 7565 (for replacement of R8184G, R7184A)**  
No valve-on or motor-off delay

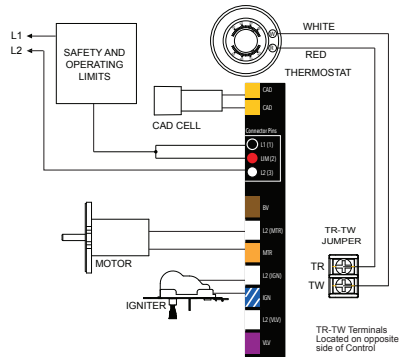

**Figure 7 – 7565 (for replacement of R7184B)**  
Valve-on delay only (no motor-off delay)

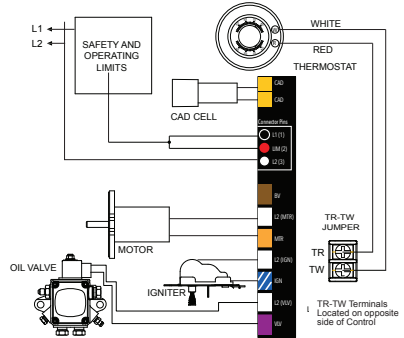

**Figure 8 – 7565 (for replacement of R7184P)**  
Valve-on and motor-off delays

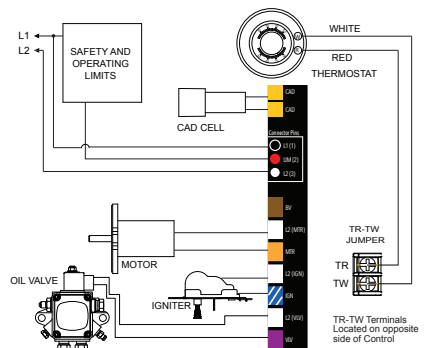

**NOTE:** all wiring diagrams (except Figure 3) can be configured for intermittent or interrupted ignition

## Appendix C - Thermostat Wiring Requiring a Common (C) Terminal

Figure 9 - 3-Wire Thermostat

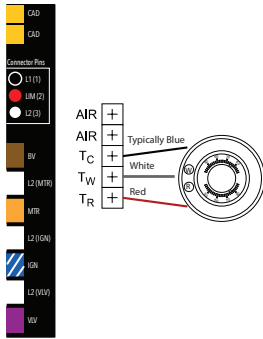
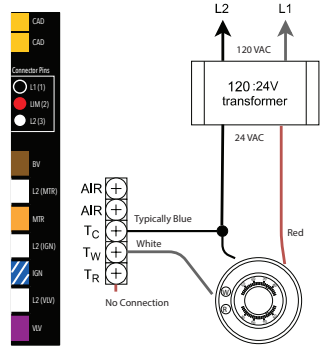

Figure 10 - Thermostat Wiring with External Transformer  
For example, an air conditioning transformer.



## Appendix D - Typical Air Input Wiring

Figure 11 - 24Vac Blocked Vent Wiring

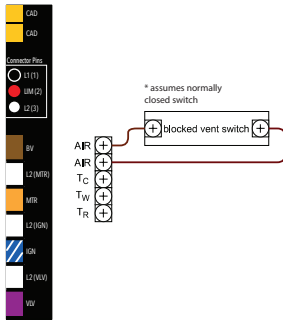

Figure 12 - 24Vac Combustion Air Proving Wiring

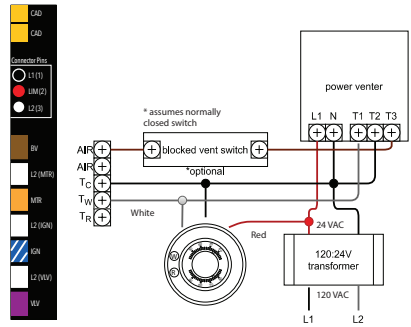

Figure 13 - 120Vac Blocked Vent Wiring

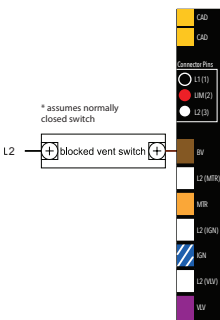
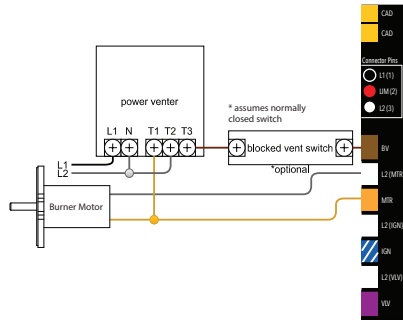

Figure 14 - 120Vac Combustion Air Proving Wiring



## Limited Warranty Information

The R. W. BECKETT CORPORATION ("Beckett") warrants to persons who purchase its "Products" from Beckett for resale, or for incorporation into a product for resale ("Customers"), that its equipment is free from defects in material and workmanship. To qualify for warranty benefits, products must be installed by a qualified service agency in full compliance with all codes and authorities having jurisdiction, and used within the tolerances of Beckett's defined product specifications.

To review the complete warranty policy and duration of coverage for a specific product, or obtain a written copy of warranty form 61545, please choose one of the following options:

1. Visit our website at: [www.beckettcorp.com/warranty](http://www.beckettcorp.com/warranty)
2. Email your request to: [rwb-customer-service@beckettcorp.com](mailto:rwb-customer-service@beckettcorp.com)
3. Write to: R. W. Beckett Corporation, P. O. Box 1289, Elyria, OH 44036

**NOTE: Beckett is not responsible for any labor cost for removal and replacement of equipment.**

THIS WARRANTY IS LIMITED TO THE PRECISE TERMS SET FORTH ABOVE, AND PROVIDES EXCLUSIVE REMEDIES EXPRESSLY IN LIEU OF ALL OTHER REMEDIES, AND IN PARTICULAR THERE SHALL BE EXCLUDED THE IMPLIED WARRANTIES OF MERCHANTABILITY AND FITNESS FOR A PARTICULAR PURPOSE. IN NO EVENT WILL BECKETT BE LIABLE FOR ANY INCIDENTAL OR CONSEQUENTIAL DAMAGE OF ANY NATURE. Beckett neither assumes, nor authorizes any person to assume for Beckett, any other liability or obligation in connection with the sale of this equipment. Beckett's liability and Customer's exclusive remedy is limited to the cost of the product.