

BALDOR® • RELIANCE 

Product Information Packet

JM3155

2HP,3450RPM,3PH,60HZ,56J,3430M,OPEN,F1

Part Detail							
Revision:	R	Status:	PRD/A	Change #:		Proprietary:	No
Type:	AC	Elec. Spec:	34WGX636	CD Diagram:	CD0005	Mfg Plant:	
Mech. Spec:	34F038	Layout:	34LYF038	Poles:	02	Created Date:	
Base:	N	Eff. Date:	08-23-2018	Leads:	9#18		

Specs			
Catalog Number:	JM3155	Insulation Class:	B
Enclosure:	OPEN	Inverter Code:	Not Inverter
Frame:	56J	KVA Code:	L
Frame Material:	Steel	Lifting Lugs:	No Lifting Lugs
Output @ Frequency:	2.000 HP @ 60 HZ	Locked Bearing Indicator:	Locked Bearing
Synchronous Speed @ Frequency:	3600 RPM @ 60 HZ	Motor Lead Quantity/Wire Size:	9 @ 18 AWG
Voltage @ Frequency:	460.0 V @ 60 HZ	Motor Lead Exit:	Ko Box
	230.0 V @ 60 HZ	Motor Lead Termination:	Flying Leads
XP Class and Group:	None	Motor Type:	3430M
XP Division:	Not Applicable	Mounting Arrangement:	F1
Agency Approvals:	CSA	Power Factor:	86
	UR	Product Family:	General Purpose
Auxillary Box:	No Auxillary Box	Pulley End Bearing Type:	Ball
Auxillary Box Lead Termination:	None	Pulley Face Code:	C-Face
Base Indicator:	No Mounting	Pulley Shaft Indicator:	Ext Thread
Bearing Grease Type:	Polyrex EM (-20F +300F)	Rodent Screen:	None
Blower:	None	RoHS Status:	ROHS COMPLIANT
Current @ Voltage:	2.700 A @ 460.0 V	Shaft Extension Location:	Pulley End

	5.400 A @ 230.0 V	Shaft Ground Indicator:	No Shaft Grounding
	6.400 A @ 208.0 V	Shaft Rotation:	Reversible
Design Code:	B	Shaft Slinger Indicator:	No Slinger
Drip Cover:	Drip Cover	Speed Code:	Single Speed
Duty Rating:	CONT	Motor Standards:	NEMA
Electrically Isolated Bearing:	Not Electrically Isolated	Starting Method:	Direct on line
Feedback Device:	NO FEEDBACK	Thermal Device - Bearing:	None
Front Face Code:	Drip Cover Mounting	Thermal Device - Winding:	None
Front Shaft Indicator:	None	Vibration Sensor Indicator:	No Vibration Sensor
Heater Indicator:	No Heater	Winding Thermal 1:	None
		Winding Thermal 2:	None

Nameplate NP1256L										
CAT.NO.	JM3155									
SPEC.	34F038X636									
HP	2									
VOLTS	230/460									
AMP	5.4/2.7									
RPM	3450									
FRAME	56J				HZ	60			PH	3
SER.F.	1.20			CODE	L	DES	B		CLASS	B
NEMA-NOM-EFF	82.5			PF	86					
RATING	40C AMB-CONT									
CC									USABLE AT 208V	6.4
DE	6203				ODE	6203				
ENCL	OPEN			SN						
	SFA 6.2/3.1									

Parts List		
Part Number	Description	Quantity
SA043930	SA 34F038X636	1.000 EA
RA039392	RA 34F038X636	1.000 EA
NS2512A01	INSULATOR, CONDUIT BOX X	1.000 EA
34CB3002A	CB CAST W/.88 DIA HOLE	1.000 EA
51XB1016A07	10-16 X 7/16 HXWSSLD SERTYB	2.000 EA
11XW1032G06	10-32 X .38, TAPTITE II, HEX WSHR SLTD U	1.000 EA
34EP3212A03	FR EP 34L FOR DRIP CVR	1.000 EA
HW5100A03	WAVY WASHER (W1543-017)	1.000 EA
34EP3401A01SP	PU ENDPLATE, MACH	1.000 EA
34AD2000	BAFFLE PLATE, STAMPED	1.000 EA
60XW0632A06	6-32 X 3/8 TORX HEAD SCREW TAPTITE II	4.000 EA
51XN1032A20	10-32 X 1 1/4 HX WS SL SR	2.000 EA
34FH4000A15	DRIP COVER, STAMPED,PRIMER	1.000 EA
51XW1032A06	10-32 X .38, TAPTITE II, HEX WSHR SLTD S	3.000 EA
WD4101A09	STIMPSON D3560, .875 DIA. HOLE PLUG	1.000 EA
34CB4517	CB LID 4 MTG HOLES .22 DIA STAMPED, FOR	1.000 EA
51XW0832A07	8-32 X .44, TAPTITE II, HEX WSHR SLTD SE	4.000 EA
RM1010A01	35-968-1 VINYL CLS	1.000 EA
MG1000G27	MED CHARCOAL METALLIC GREY 400-0096	0.014 GA
85XU0407S04	4X1/4 U DRIVE PIN STAINLESS	2.000 EA
HA3100A38	THRUBOLT 10-32 X 9.375	4.000 EA
MN416A01	TAG-INSTAL-MAINT no wire (1200/bx) 3/19	1.000 EA
LC0005E01	CONN.DIA./WARNING LABEL (LC0005/LB1119N)	1.000 EA
NP1256L	ALUM UL CSA CC INDUSTRIAL MOTOR A60	1.000 EA

Parts List (continued)		
Part Number	Description	Quantity
35PA1000	PKG GRP, PRINT PK1008A06	1.000 EA
PK3083	STYROFOAM PACKING CRADLE	1.000 EA
PK3088	MICROFOAM, 8"X"8 PERF. SHEETS 5,400/RL	1.000 EA

No performance data has been
assigned to this product.

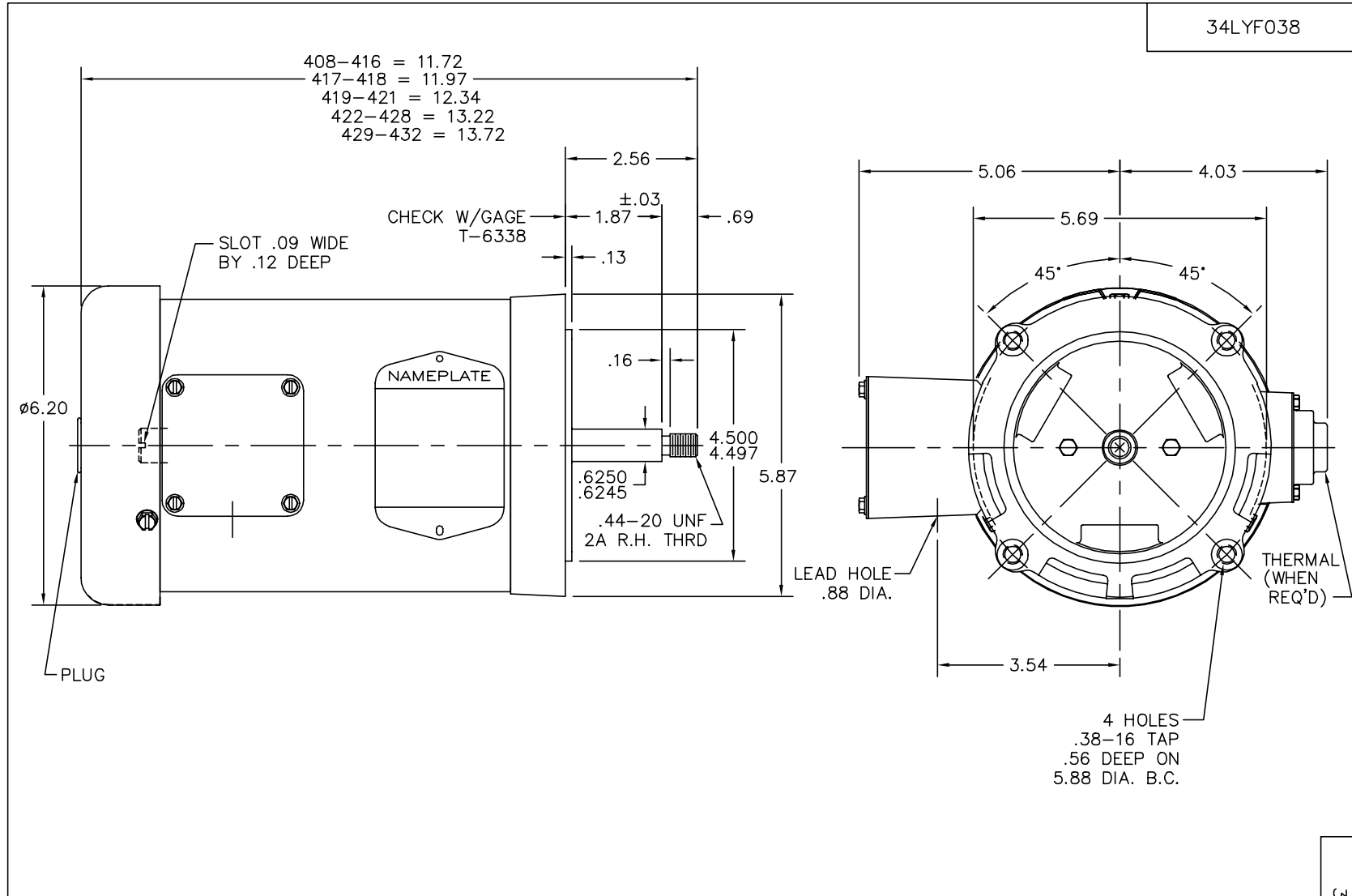

CUSTOMER IS RESPONSIBLE FOR DETERMINING THAT MOTOR PERFORMANCE IS SUITABLE IN THE APPLICATION.

REV. DESC: NEW KBOX & LID			
REV. LTR: H	BY: RT	REVISED: 11:57:23 10/14/2003	TDR: 314971
34LYF038		FILE: AAA00026304	REF: 34LYF038
		MTL: -	

BALDOR ELECTRIC Co.

STD VERT 56J OPEN 34M W/DRIP CVR

34LYF038

CD0005



LOW VOLTAGE
(2Y)



HIGH VOLTAGE
(1Y)

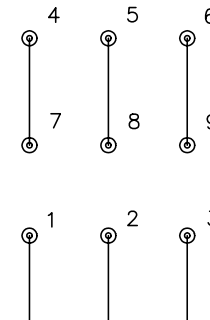

NOTES:

1. INTERCHANGE ANY TWO LINE LEADS TO REVERSE ROTATION.
2. OPTIONAL THERMOSTATS ARE PROVIDED WHEN SPECIFIED.
3. ACTUAL NUMBER OF INTERNAL PARALLEL CIRCUITS MAY BE A MULTIPLE OF THOSE SHOWN ABOVE.
4. LEAD COLORS ARE OPTIONAL. LEADS MUST ALWAYS BE NUMBERED AS SHOWN.

REV. DESC: REVISE TO SHOW OPTIONAL COLORS			
REV. LTR: E	BY: JLP	REVISED: 01/19/99 10:15	TDR: 0171435
90000		FILE: AAA00005140	MDL: -
		MTL: -	

BALDOR ELECTRIC Co.

3PH, DV, 9 LEADS

CD0005