

Commercial Product Catalog





Innovation Has A Name.

It should come as no surprise that a company that has built its reputation on the concept of innovation continues to lead the industry with the broadest—and, yes, the most innovative—selection of water heaters and boilers in its long and storied history.

What *might* come as a surprise to some is the fact that we view this accomplishment as a mere beginning—an indication of even greater things still to come. For everyone here at A. O. Smith, it's never been just about outdoing what we have achieved in the past—it's always been about exceeding everyone's expectations for the future. Which is why you, our customers, can count on us to provide you with the perfect water heater solution for any application—day after day, year after year.



Table of Contents

- A. O. Smith Innovation and Quality 3
- iCOMM™ and iCOMM™ Elite Remote Monitoring System 4–5
- Gas Water Heaters 6–17
- Power Burner Gas Water Heaters 18–20
- Oil-Fired Water Heaters 21–23
- Electric Heat Pump Water Heaters 24–25
- Electric Water Heaters 26–31
- Boilers 32–49
- Ac-U-Temp Hot Water Supply Systems 50–51
- Electric Boilers & Hot Water Generators 52–53
- Custom Semi-Instantaneous Water Heaters 54–55
- Storage Tanks/Hot Water Generators 56–57
- Commercial Line Overview & Support Network 58–59

A. O. Smith innovation and quality...engineered into every product from the inside out.

The Eliminator™ Self-Cleaning Technology In Master-Fit® Models

A. O. Smith Master-Fit commercial gas water heaters have always provided maximum installation flexibility for both new construction and replacement applications. Now, Master-Fit offers The Eliminator for automatic self-cleaning protection against build-up of lime and other sediments.

As deposits of lime and other sediments accumulate inside the tank, they form a barrier between the burner and the water, concentrating heat around the critical weld areas. The result is reduced energy efficiency, higher operating costs, and greater risk of premature tank leaks.

The Eliminator directs incoming cold water under pressure to sweep the bottom of the tank to keep sediment moving so it doesn't accumulate.

With The Eliminator, every Master-Fit water heater can be expected to maintain its rated efficiency longer and deliver reliable service year after year.



PermaGlas® Ultra Coat™ Glass Coating

Nothing protects like it, and nobody offers it but A. O. Smith. PermaGlas Ultra Coat is an exclusive "slush coat" process that heat-bonds glass to each tank's inner surface after all connections and seams have been welded. Because it's a slush coating process instead of a spray-on coating, PermaGlas Ultra Coat covers and protects better.

And because A. O. Smith PermaGlas Ultra Coat is applied after the tank is welded, there is no chance of "weld burn" that can burn away normal glass lining and expose bare steel to water.

PermaGlas Ultra Coat provides protection for the tank's top, bottom, and outer shell and all weld seams.



All welds completed prior to PermaGlas Ultra Coat.



Once tanks are filled with PermaGlas, they are rotated (computer controlled) for precise, even coating.



Technician removes hand-hole clean-out to prepare it for the next step.



Tanks are then rotated further, allowing the excess PermaGlas to drain from the tank.

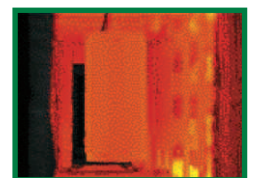

After pre-drying in 200°F ovens, the tanks are then fired to 1,600°F, fusing the PermaGlas to the steel tank.

iCOMM™ Remote Monitoring System

For information and ordering call 1-888-WATER02 or visit www.aosmithconnect.com

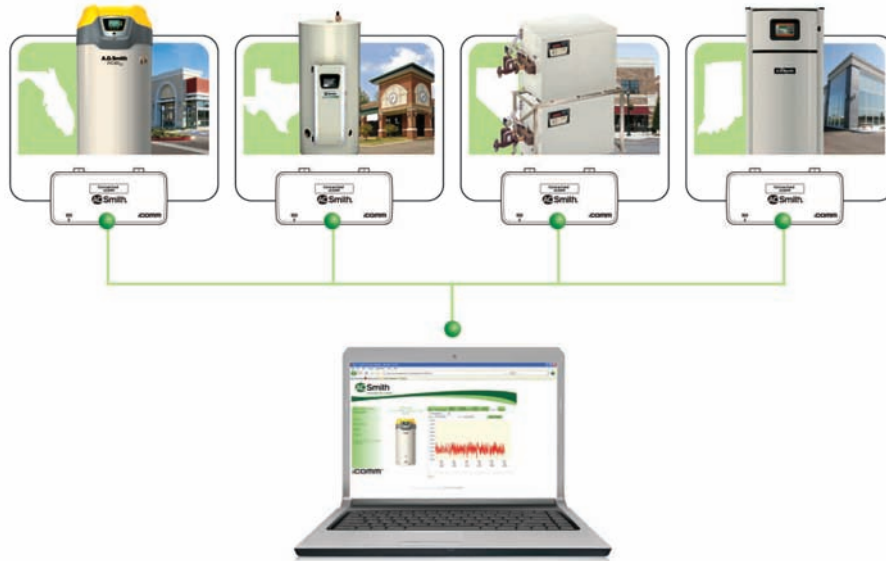

Hardware

MODEL NO.	ITEM	DESCRIPTION
ICMA	iCOMM Communications Module	Main communications board required for any iCOMM installation.
IMDA	iCOMM Multi-Device Adapter	Needed if more than one water heater will be connected to the control module. Order 1 MDA for each water installed.
IABA	iCOMM Alarm Box	Accessory alarm box that includes an audible alarm and alarm light.



Note: If using wireless internet an optional wireless adapter is needed to provide wired connection to the communications module. Recommended adapter Linksys WGA600N or equivalent

iCOMM Features

- Provides remote monitoring via www.aosmithconnect.com
- E-mail and text messaging of fault conditions
- Leak detection and notification
- Graphs unit performance and operational history
- BACnet compatibility with building management systems

iCOMM Requirements

- Facility must have "always on" internet (wired or wireless)
- iCOMM compatible water heater or boiler
- Annual iCOMM subscription

Compatible Units Include:

- Cyclone® Xi
- Custom Xi (DSE models) and Gold Xi (DVE models)
- Genesis® Boilers
- VF™ Variable Fire Series Boilers

iCOMM™ Subscription (required) per iCOMM Communication Module

Note - iCOMM subscription is required to utilize any and all functions of the iCOMM remote monitoring system or the "iCOMM Elite service". (See page 5 for more information). End user responsible for paying and maintaining annual subscription. Installation and subscription service fees are net prices paid directly by the end user. No distributor discounts are applicable.



For information and ordering call
1-888-WATER02 or visit
www.aosmithconnect.com

iCOMM™ *Elite* Monitoring Service

iCOMM™ ELITE

Complete Coverage, Total Peace

What is iCOMM™ Elite?

iCOMM™ Elite utilizes the latest technology in commercial water heating to allow us to interact with, proactively manage and monitor your A. O. Smith water heaters or boilers from anywhere in the world via the Internet. With this newly redesigned industry-exclusive service, A. O. Smith can monitor your water heaters around the clock, alert you instantly in case of a problem, and begin fixing any potential problems immediately. How is that for ultimate peace of mind?

Who is iCOMM Elite Designed For?

Any commercial water heater customers, ranging from small businesses with one water heater to national chain operations with thousands of locations.

Elite Compatible Units Include:

- Cyclone® Xi
- Custom Xi (DSE models) and Gold Xi (DVE models)

Valet Service on Any Warranty Claim!

Should you experience problems with any products that are still under warranty—it's time for the VIP treatment. We will do everything to get you back on track, and we mean everything. Our complete valet service includes a call before the service, handling all the logistics, repairing the product, and of course, superior service throughout the process.



Get iCOMM™ Elite in **3** Easy Steps

1. Confirm you have a compatible unit.
2. Verify that you have an Internet connection in the same room as the water heater(s).
3. Call 1-888-WATER02 to purchase and arrange installation.

iCOMM™ Subscription (required) per iCOMM Communication Module

Note - iCOMM subscription is required to utilize any and all functions of the iCOMM remote monitoring system or the "iCOMM Elite service". End user responsible for paying and maintaining annual subscription. Installation and subscription service fees are net prices paid directly by the end user. No distributor discounts are applicable.

Conservationist® BPD Gas Power Direct Vent Models

80% thermal efficiency, ideal for commercial applications and where negative air pressure is a problem



The Conservationist® BPD-75 tank-type commercial gas water heater is intended for applications such as small office buildings and duplex apartment homes. The BPD-75 features a power direct vent design with a factory-installed blower. The blower permits sealed combustion direct vent operation with separate venting and air intake runs from outside the structure. The BPD-75 offers installation versatility by allowing venting and intake runs up to 50 feet, using 3" Schedule 40 PVC pipe. The power direct vent design also eliminates the potential for performance and safety problems caused by negative air pressure, which is found in many commercial applications with inadequate indoor ventilation.

DynaClean™ II Automatic Sediment-Cleaning System

- Specially designed dip tube directs incoming cold water to create turbulence in the tank to reduce lime and sediment build-up
- Prolongs tank life, maintains high energy efficiency, maximizes hot water output

Quiet Modular Blower

- Built-in safety device prevents pilot or main burner operation if blower is not operating
- Blower has 110V/120V electrical system, with maximum 2A draw

Durable Brass Drain Valve

CSA Certified and ASME Rated T&P Relief Valve, Factory-Installed

Meets the Thermal Efficiency and Standby Loss Requirements of U. S. Department of Energy and Current Edition of ASHRAE/IESNA 90.1

Maximum Hydrostatic Working Pressure: 150 PSI

3-Year Limited Tank Warranty



All dimensions in inches

MODEL NO.	GAL. CAP.	BTU INPUT PER HOUR	FIRST HOUR DELIVERY RATING	RECOVERY			HT.	DIA.	APPROX. SHIP WEIGHT
				GPH/°F	TEMP. RISE				
BPD-75 Natural	75	70,000	117	161	64	46	69-5/8	26	352
BPD-75 Propane	75	65,000	112	148	59	42	69-5/8	26	352

Conservationist® BTF Gas Power Vent Single Flue Models

“Environmentally-Friendly” Non-CFC Foam Insulation

- Minimizes radiant heat loss.

Dip Tube

- Carries inlet water deep into tank.

Hot Surface Ignition

- Has a solid state ignition surface that does not flutter or blow out. Provides increased reliability and efficiency over spark ignition systems. Eliminates the pilot and saves energy.

Intelli-Vent™ Control

- Provides temperature control and LED diagnostics.

Glasslined Tank

- Glass specifically developed by A. O. Smith for water heaters is permanently fused to steel at 1600°F, providing years of corrosion protection and dependable use.

Anode

- Tank-mounted, screw-in replaceable anode for longer tank life.

High Input

- 80,000 BTU input assures plenty of hot water is available by providing faster recovery rates and higher first hour draws.

Burner

- High input, multiport burner for improved combustion efficiency and low NOx.

Turbo Shot™ Combustion System

- Air is precisely drawn through the combustion control port and exhausted through plastic pipe. Controlling the airflow through the heater enhances and regulates the combustion process. In standby mode, the combustion control port restricts air circulation through the heater.

Power Venting

- Provides more venting flexibility and savings. A new quiet blower allows exhaust venting through the roof or sidewall with plastic pipe such as PVC, CPVC, and ABS. Allowable vent lengths of up to 100 equivalent feet make installation easy in any situation. BTF-80 is a Category 3 (positive pressure non-condensing) appliance.

CSA Certified and ASME Rated T&P Relief Valve, Factory-Installed



All dimensions in inches

MODEL NO.	GAL. CAP.	BTU INPUT PER HOUR	FIRST HOUR DELIVERY RATING	RECOVERY			HT.*	DIA.	APPROX. SHIP WEIGHT
				GPH/°F	TEMP. RISE				
BTF-80	74	80,000	78	194	78	55	66-5/16	25-3/8	340

*Height to top of draft hood

Intelli-Vent™ is a Registered Trademark of Emerson Electric Company

Conservationist® BT Gas Models

80% thermal efficiency, ideal for many commercial applications



Conservationist® BT models provide reliable, efficient service for applications such as office buildings and duplex/fourplex apartment homes.

CoreGard™ Anode Rod

- Stainless steel core won't corrode, won't break away

PermaGlas® Glass Lining

- Glass lining and anode rod protect steel tank from corrosion

Fully Automatic Controls

- Includes automatic safety shutoff gas if pilot is extinguished and high temperature energy cutoff (ECO)

Compact Design

- Smaller diameters and shorter heights for greater installation flexibility

Plastic Leg Construction

- Three-leg design

Piezo Ignitor

- Natural gas models only

Burner Head Mounted Pilot

- Natural gas models only

CSA Certified and ASME Rated T&P Relief Valve, Factory-Installed

Meets the Thermal efficiency and standby loss requirements of the U.S. Department of Energy and current edition of ASHRAE/IESNA90.1

3-Year Limited Tank Warranty

5-Year limited Tank Warranty Optional

All dimensions in inches

MODEL NO.	GAL. CAP.	BTU INPUT PER HOUR	FIRST HOUR DELIVERY RATING	RECOVERY			HT.	DIA.	APPROX. SHIP WEIGHT
				GPH/°F	TEMP. RISE				
				40	100	140			
BT MODELS									
BT-65	65	65,000*	109	158	60	45	65	24	215
BT-80	74	75,100	125	182	73	52	61	27-3/4	275
BT-100	98	75,100	142	182	73	52	68-1/2	27-3/4	350

* Propane Model rated at 55,000 BTU

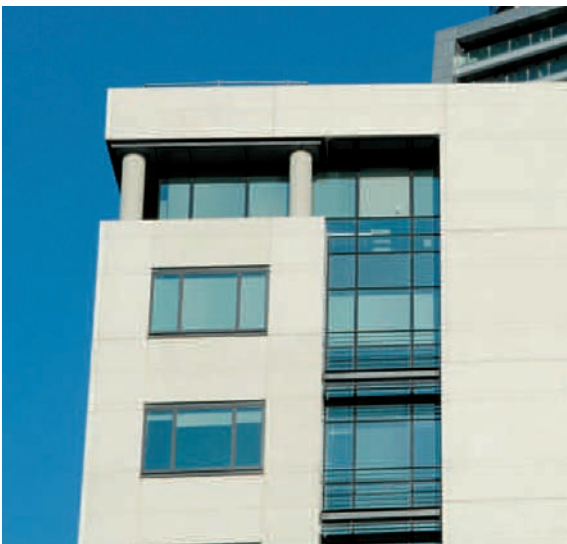

80% Thermal Efficiency, ideal for applications requiring Low NOx

Induced Draft Low NOx BTN Gas Models

Conservationist® BTN models are equipped with a blower that produces a power-induced draft of make-up air prior to burner ignition.

Complies with SCAQMD Rule 1146.2 and other Air Quality Management Districts with Similar Requirements*

Category 1 Appliance

- Can be commonly vented with other Category 1 appliances and uses standard metal single-wall type "B" vent, connected directly to blower outlet

Factory-Mounted, Pre-Wired Blower

- With 6-foot power cord, provides pre-ignition draft

PermaGlas® Glasslined Tank

- Glass lining and anode rod protect steel tank from corrosion

Intelli-Vent™ Gas Control Valve

- Advanced electronic valve features polarity sensing to help ensure proper operation
- Easy-to-understand diagnostics and a nearly indestructible hot surface ignitor

Certified For Use On Combustible Flooring

Handhole Clean Out

- Allows easy maintenance

3-Year Limited Tank Warranty

5-Year Limited Tank Warranty Optional



All dimensions in inches

MODEL NO.	GAL. CAP.	BTU INPUT PER HOUR	FIRST HOUR DELIVERY RATING	RECOVERY			HT.*	DIA.	APPROX. SHIP WEIGHT
				GPH/°F	TEMP. RISE				
				40	100	140			
BTN MODELS									
BTN-80	74	80,000 (Nat)	137	193	77	55	66-5/16	25-3/8	300
BTN-80	74	76,000 (LP)	126	184	74	53	66-5/16	25-3/8	300
BTN-100	98	90,000 (Nat)	175	218	87	62	71-1/4	26-1/2	350
BTN-100	98	80,000 (LP)	156	193	77	55	71-1/4	26-1/2	350

* Height to top of the draft hood

*After January 1st, 2012 Models will no longer comply with SCAQMD Rule 1146.2 requirements for low NOx emissions.

Intelli-Vent™ is a Registered Trademark of Emerson Electric Company

BTR Gas Models

80% thermal efficiency, self-cleaning,
easy to install



The Master-Fit® BTR series provides outstanding performance and maximum installation flexibility for both new construction and replacement applications. Each unit is designed to be as much as a foot shorter than the models they usually replace, and multiple options for placement of water connections and low installation clearances are additional installer-friendly features.

The Eliminator™ Self-Cleaning System

As deposits of lime and other sediments accumulate inside the tank, they form a barrier between the burner and the water, concentrating heat around the critical weld areas. The result is reduced energy efficiency, higher operating costs, and a greater risk of premature tank leaks. The Eliminator™ directs incoming cold water under pressure to sweep the bottom of the tank to keep sediment moving so it doesn't accumulate. Reduced sediment build-up helps maintain rated thermal efficiency and reduce water heating costs. The self-cleaning system also helps prolong tank life to ensure year after year of reliable service.



Factory-Installed Draft Diverter And Flue Damper

- Low-profile draft diverter helps for installation in tight spaces
- Automatic motorized flue damper helps minimize standby heat loss

Three Water Connection Options

- Hot and cold water connections can be made through front, top or rear of unit
- The Eliminator™ system operates when cold water is connected through front

PermaGlas® Ultra Coat™ Glasslining

- Exclusive process provides superior protection against corrosion
- CoreGard™ anode rods with stainless steel core provide additional corrosion protection

Optional Power Vent Kit Systems

- BTR 120-200 pln 9005381205
- BTR 250-500 pln 9003434205

Intermittent Electronic Ignition

- Eliminates standing pilot, saves energy
- Includes power ON/OFF switch
- Provides flame failure response in less than one second

Meets the Thermal efficiency and standby loss requirements of the U.S. Department of Energy and current edition of ASHRAE/IESNA90.1

CSA Certified and ASME Rated T&P Relief Valve, Factory-Installed

Maximum Hydrostatic Working Pressure: 160 PSI

Fully Automatic Control System

- Manual-reset gas shutoff device prevents excessive water temperature
- Electric temperature control for precise temperature regulation adjustable 120°F–180°F
- Gas pressure regulator and pilot filter

Handhole Clean Out

- Allows easy access to tank interior for cleaning

3-Year Limited Tank Warranty

5-Year Limited Tank Warranty
Optional

Master-Fit®

80% thermal efficiency, ideal for restaurant applications

BTR Gas Models Including Booster Models

The Master-Fit® BTR-151 and BTR-201 are designed for installation in “booster” applications to supply commercial dishwashers with very high temperature water. A booster water heater is normally used in conjunction with a standard water heater delivering hot water at a lower temperature to meet the non-dishwashing needs of a restaurant or other food service application. With 32 gallons stored, these compact units measure only 45” high, and hot and cold water connections can be made in the top, front or rear for installation versatility.

The Features Of The Master-Fit BTR Plus Booster Models:

Built-In Induced Draft Blower

- Produces power-induced draft of make-up air prior to burner ignition
- Provides more efficient control of heat through the flue collector
- No draft hood or barometric damper required

Rated As Category 1 Appliance

- Can be commonly vented with other Category 1 appliances, using standard metal type “B” vent

Meets the Thermal efficiency and standby loss requirements of the U.S. Department of Energy and current edition of ASHRAE/IESNA90.1



All dimensions in inches

MODEL NO.	GAL. CAP.	BTU INPUT PER HOUR	FIRST HOUR DELIVERY RATING	RECOVERY			HT.**	DIA.	APPROX. SHIP WEIGHT	
				40	100	140			STD.	ASME
BTR-120	71	120,000	166	291	116	83	69-3/4	27-3/4	400	-
BTR-154	81	154,000	206	373	149	107	73	27-3/4	470	-
BTR-180	81	180,000	231	434	175	124	67-1/2	27-3/4	470	-
BTR-197	100	199,000	263	482	193	132	75	27-3/4	603	-
BTR-198	100	199,000	263	482	193	132	75	27-3/4	603	-
BTR-199	81	199,000	250	482	193	132	67-1/2	27-3/4	470	-
BTR-200(A)*	100	199,000	263	482	193	132	72	30-1/4	630	725
BTR-250(A)*	100	250,000	312	606	242	173	72	30-1/4	630	725
BTR-251(A)	65	251,000	289	608	243	174	75	27-3/4	750	862
BTR-275(A)*	100	275,000	337	667	267	90	72	30-1/4	630	725
BTR-305(A)	65	305,000	342	739	296	211	75	27-3/4	750	862
BTR-365(A)	85	365,000	414	885	354	243	79-1/2	27-3/4	725	833
BTR-400(A)	100	390,000	448	945	378	270	75-1/2	30-1/4	760	874
BTR-500(A)	85	500,000	545	1212	485	346	82-1/4	27-3/4	820	856
BTR BOOSTER MODELS										
BTR-151(A)	32	150,000	167	364	145	104	45	27-3/4	460	440
BTR-201(A)	32	199,900	216	485	194	139	45	27-3/4	460	440



Master-Fit®

BTR-120 Models are approved for 5” vent using a 6” to 5” reducer.
*BTR-250(A), BTR-251(A) and BTR-275(A) models shipped with a 8” to 6” vent reducer.

Certified for both 6” or 8” vent.
**Height to top of vent connection.

Induced Draft BTN Gas Models

80% thermal efficiency—
Low NOx



ASME
(Optional)

Complies with
SCAQMD
Rule 1146.2



The Master-Fit® Plus BTN series meets Southern California and Texas low NOx standards and features induced-draft design. This provides more efficient control of heat through the flue collector. Like all Master-Fit water heaters, the BTN series provides outstanding performance and maximum installation flexibility for both new construction and replacement applications. Each unit is designed to be as much as a foot shorter than the models they usually replace, and multiple options for placement of water connections and low installation clearances are additional installer-friendly features.

The Eliminator™ Self-Cleaning System

As deposits of lime and other sediments accumulate inside the tank, they form a barrier between the burner and the water, concentrating heat around the critical weld areas. The result is reduced energy efficiency, higher operating costs, and a greater risk of premature tank leaks.

The Eliminator™ directs incoming cold water under pressure to sweep the bottom of the tank to keep sediment moving so it doesn't accumulate. Reduced sediment build-up helps maintain rated thermal efficiency and reduce water heating costs. The self-cleaning system also helps prolong tank life to ensure year after year of reliable service.



Built-In Induced Draft Blower

- Factory-mounted on top of unit and pre-wired for easy installation
- Provides power-induced draft of combustion make-up air prior to burner ignition
- Requires no draft hood or barometric damper

Rated As Category 1 Appliance

- An excellent option for retrofit and upgrade installations
- Uses standard metal single-wall type "B" vent, can be commonly vented with other Category 1 appliances
- Vent connects directly to blower outlet

Three Water Connection Options

- Hot and cold water connections can be made through front, top or rear of unit
- The Eliminator™ system operates when cold water is connected through front

PermaGlas® Ultra Coat™ Glass Lining

- Exclusive process provides superior protection against corrosion
- CoreGard™ anode rods with stainless steel core provide additional corrosion protection

Compliance

- Meets the Thermal efficiency and standby loss requirements of the U.S. Department of Energy and current edition of ASHRAE/IESNA90.1
- Complies with SCAQMD Rule 1146.2 and other Air Quality Management Districts with similar requirements for low NOx emissions+

Control With Silicon Nitride Hot Surface Ignitor

- Digital solid-state diagnostic control system helps make installation and troubleshooting easy
- Digital Temperature Control adjusts thermostat setting from 120°F to 180°F, accurate to within $\pm 2^\circ\text{F}$
- Control includes Power On/Standby Indicator, ECO Open Indicator, Reset Status Indicator and Heating Mode Indicator
- Silicon nitride ignitor is rugged and dependable, equipped with separate flame prover rod
- Manual-reset gas shutoff device prevents excessive water temperature

CSA Certified and ASME Rated T&P Relief Valve, Factory-Installed

Intermittent Electronic Ignition With Solid-State Ignition Control

- Eliminates standing pilot, saves energy
- Includes power ON/OFF switch
- Provides flame failure response in less than one second

Maximum Hydrostatic Working Pressure: 160 PSI

Handhole Clean-Out

- Allows easy access to tank interior for cleaning

Plug Kits

- Pipe nipples and caps included to plug unused water connections

3-Year Limited Tank warranty

5-Year Limited Tank Warranty Optional

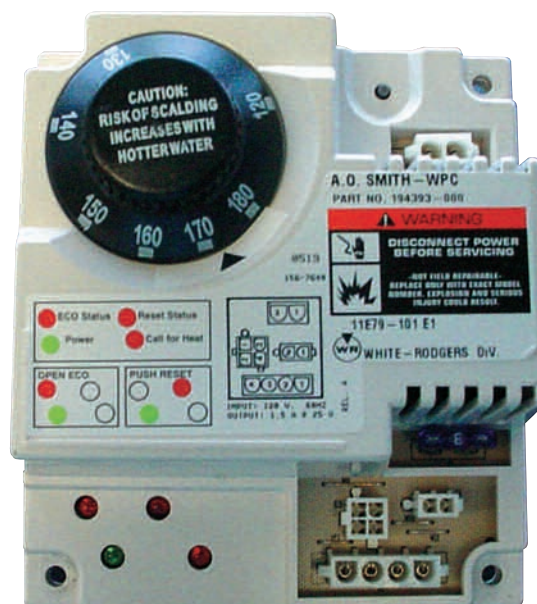

All dimensions in inches

MODEL NO.+	GAL. CAP.	BTU INPUT PER HOUR	FIRST HOUR DELIVERY RATING	RECOVERY GPH/°F TEMP. RISE			HT.	DIA.	APPROX. SHIP WEIGHT	
				40	100	140			STD.	ASME
BTN-120	71	120,000	166	240	116	83	63	27-3/4	400	-
BTN-154	81	154,000	206	373	149	107	68	27-3/4	470	-
BTN-180	99	180,000	245	436	175	125	72	27-3/4	603	-
BTN-199C*	99	199,000		482	193	138	72	27-3/4	620	-
BTN-199	99	199,000	262	482	193	138	72	27-3/4	603	-
BTN-200(A)	100	199,000	266	482	193	138	72	27-3/4	603	686
BTN-250(A)	100	250,000	312	606	242	173	72	27-3/4	603	686
BTN-270(A)	100	275,000	337	667	267	190	72	27-3/4	603	686
BTN-310(A)*	100	310,000	371	752	301	215	73	27-3/4	725	833
BTN-366(A)	85	366,000	415	887	355	253	73	27-3/4	725	833
BTN-400(A)	85	390,000	436	945	378	270	73	27-3/4	725	833

*Models meet 82% TE Utility Rebate.

BTN-199C models for sale in California only.

+After January 1, 2012, Models will no longer comply with SCAQMD Rule 1146.2 requirements for low NOx emissions.

Master-Fit
Plus

Cyclone® Xi BTH and BTX Gas Models

Up to 96% thermal efficiency, venting flexibility, outstanding value



The A. O. Smith Cyclone Xi is the industry's most technologically advanced commercial water heater. The BTH-300, BTH-400 and BTH-500 models take Cyclone Xi performance to the highest levels, with up to 96% thermal efficiency, a 130-gallon storage tank, and inputs of 300,000, 400,000 and 500,00 BTU. For high-demand applications, 2, 3 or 4 Cyclone units can be installed in a manifold configuration, delivering total storage up to 520 gallons and total input up to 2 million BTU. Cyclone Xi provides outstanding hot water output, with dramatic savings on operating costs compared to units with standard 80% efficiency. A. O. Smith's leading-edge engineering delivers conventional power vent or sealed combustion power direct vent versatility, low NOx emissions, and excellent space-saving characteristics.

Submerged Combustion Chamber, With Helical Heat Exchanger Coil

- Positioned in center of tank, surrounded by water to virtually eliminate radiant heat loss from chamber
- Spiral heat exchanger maximizes efficiency of heat transfer to the water stored in the tank
- Top mounted burner and spiral heat exchanger work together to minimize harmful effects of calcium/lime accumulation

PermaGlas® Ultra Coat™ Glass Lining

- Exclusive process provides superior protection against corrosion in varying water conditions
- Powered Anodes are of permanent design and do not require replacement unless damaged
- Both sides of heat exchanger coil are glasslined for protection against flue gas condensate inside coil

Advanced Electronic Control System with LCD Display

- iCOMM™ Compatible and can be monitored from remote locations. Call 1.888.WATER02 for more information
- Provides detailed water heater status information
- Precise temperature control
- Built-in diagnostics
- Run history information

Various Venting Options

- Conventional and sealed-combustion power venting (vertical or sidewall) allows for various venting options (See instruction manual for complete venting installation instructions and allowable venting lengths)
- Direct vent intake and exhaust pipe can terminate separately outside building or through single opening using concentric vent assembly
- Uses inexpensive PVC, CPVC or ABS pipe for venting

Compliance

- Meets the Thermal efficiency and standby loss requirements of the U.S. Department of Energy and current edition of ASHRAE/IESNA90.1

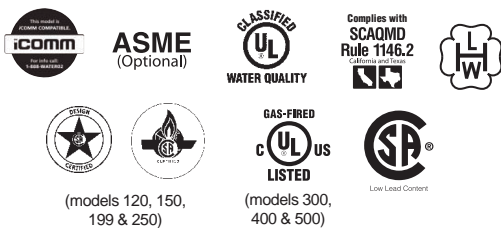

(models 120, 150, 199 & 250)

(models 300, 400 & 500)



Unrivalled Venting Versatility

The Cyclone Xi features power-vent and power direct vent design, allowing combustion air to be drawn from the equipment room conventionally or directly from the outdoor atmosphere through a sealed intake air pipe. Vent systems can be terminated vertically through the ceiling or horizontally through a sidewall.

Sealed Direct Vent Vertical



4" Vent
120' Intake
120' Exhaust

3" Vent
50' Intake
50' Exhaust

Sealed Direct Vent Sidewall

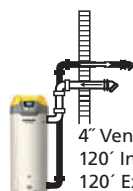

4" Vent
120' Intake
120' Exhaust

3" Vent
50' Intake
50' Exhaust

Indoor Conventional Vertical



4" Vent
120' Exhaust

3" Vent
50' Exhaust

Indoor Conventional Sidewall

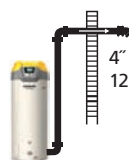

4" Vent
120' Exhaust

3" Vent
50' Exhaust

*Chart applies to BTH-120 through BTH-250 models only.
*4" PVC required on BTH-300 through BTH-500 for up to 70 equivalent feet of venting.
6" PVC Required for longer installations
See instruction manual for complete venting instructions and allowable vent lengths.

Space-Saving Design For Installation Flexibility

- Top cover has rear cut-away for easy access to serviceable parts
- 0" installation clearances on sides and rear, 2" installation clearance on top, 4" alcove installation clearance in front of unit
- 0" clearance to combustibles (walls, floors, etc.)

Powered Anodes (Excluding BTX-100 Models)

- No maintenance required
- Superior tank protection
- Adjusts to water conditions

Revolutionary Heat Exchanger And Burner Systems

The internal helical heat exchanger keeps the hot flue gasses inside the heater longer, producing an extra-high rate of heat transfer, resulting in higher thermal efficiency. All Cyclone Xi models employ an ingenious top-mounted down-fire pre-mix burner, resulting in even higher efficiencies.



All dimensions in inches

MODEL NO.	GALLON CAPACITY	FIRST HOUR DELIVERY RATING	RECOVERY CAPACITY GPH 100°F RISE	VENT SIZE	INPUT BTU/HR NATURAL GAS	HT.	DIA.	APPROX. SHIP WEIGHT
BTH-120	60	180	138	3	120,000	55-1/2	27-3/4	460
BTH-150	100	243	173	3	150,000	75-1/2	27-3/4	555
BTH-199	100	300	230	3	199,000	75-1/2	27-3/4	555
BTH-250	100	358	288	3	250,000	75-1/2	27-3/4	555
BTH-300	130	440	349	4	300,000	75-1/2	33-1/8	855
BTH-400	130	557	465	4	399,900	75-1/2	33-1/8	855
BTH-500	130	667	576	4	499,900	75-1/2	33-1/8	855
BTH-120A	60	180	138	3	120,000	55-1/2	27-3/4	490
BTH-150A	100	243	173	3	150,000	75-1/2	27-3/4	595
BTH-199A	100	300	230	3	199,000	75-1/2	27-3/4	595
BTH-250A	100	358	288	3	250,000	75-1/2	27-3/4	595
BTH-300A	130	440	349	4	300,000	75-1/2	33-1/8	855
BTH-400A	130	557	465	4	399,900	75-1/2	33-1/8	855
BTH-500A	130	667	576	4	499,900	75-1/2	33-1/8	855
BTX-100	50	164	116	4	100,000	66-3/4	22	255



Cyclone® HE BTX-80

76,000 BTU, 90%
thermal efficiency



The 50-gallon power vent Cyclone HE is designed to produce more hot water than any commercial gas water heater in its class. Thanks to the internal helical heat exchanger—similar to the design of the industry-leading Cyclone Xi models—the unit achieves 90% thermal efficiency. With its small footprint and easy installation, Cyclone HE delivers heavy-duty performance for numerous light-duty smaller applications, making it a perfect choice for restaurants, offices and other applications.

Helical Coil Heat Exchanger

- Submerged heat exchanger provides much greater heat transfer surface than standard straight flue tube
- Produces 90% thermal efficiency, which saves money on operating costs, and increases hot water output compared to standard-efficiency water heaters

Versatile Power Vent Design

- System allows combined vertical and horizontal vent runs, using 2 or 3" PVC, ABS or CPVC pipe

Modular Blower

- A condensate drain supplied to connect heat exchanger outlet to blower
- PVC Vent Attenuation Assembly (VAA) supplied for applications where extra-quiet operating environment is essential

High Output With Small Footprint

- 22" diameter, combined with 90% efficiency, 76,000 BTU input means Cyclone HE can be installed in less space than a larger 75-gallon unit with equal or better performance

PermaGlas® Ultra Coat™ Glass Lining

- A. O. Smith exclusive process provides superior protection against corrosion
- Protects all interior tank surfaces including inside and outside of helical heat exchanger

Intelli-Vent™ Gas Control

- Equipped with long-lasting silicon nitride hot surface ignitor—no standing pilot
- Advanced electronics for more precise control of water temperature and simplified system diagnostics
- 180°F maximum temperature setting

Side-Mounted Hot And Cold Recirculating Taps

- Allows Cyclone HE to be installed as part of combination space heating/water heating applications, or any system requiring a recirculating hot water loop
- Plugs for the recirculating taps are factory installed

Two Heavy-Duty Anode Rods

- Provide advanced protection against corrosion

Intelli-Vent™ is a Registered Trademark of Emerson Electric Company

Superior Heat Transfer

By utilizing the innovative internal heat exchanger coil, the Cyclone HE provides superior heat transfer characteristics, resulting in an unprecedented 90% thermal efficiency, far beyond a standard water heater design. Gallon for gallon, the Cyclone HE will heat water for significantly less, resulting in substantial savings on energy costs.

With as much power as larger water heaters in a standard 50-gallon footprint, the Cyclone HE is the natural choice for upgrading during a renovation. And the versatile power vent design allows combined vertical and horizontal vent runs of up to 128 equivalent feet. Cyclone HE provides superior savings on energy costs.

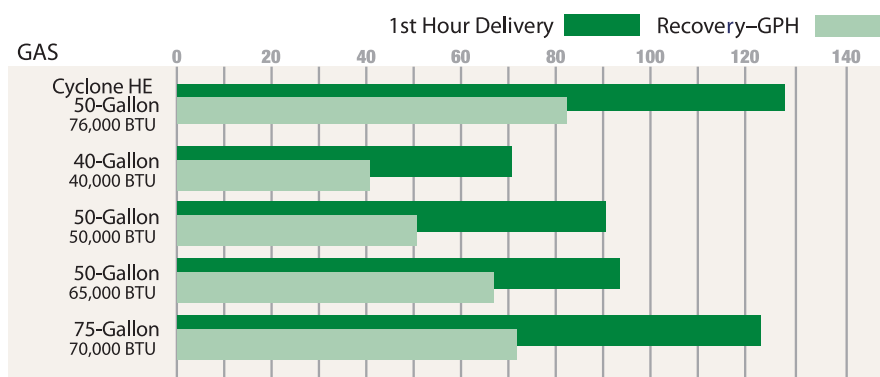

The classic Cyclone helical heat exchanger coil delivers 90% thermal efficiency.

All dimensions in inches

MODEL NO.	GAL. CAP.	BTU INPUT PER HOUR NATURAL GAS	FIRST HOUR DELIVERY RATING	RECOVERY GPH/°F TEMP. RISE			HT.*	DIA.	APPROX. SHIP WEIGHT
				40	100	140			
BTX-80	50	76,000	127	206	83	59	68-1/4	22	210

*Height to top of the heater
 " Not available in LP gas"

SUGGESTED SPECIFICATION

Natural gas water heater shall be A. O. Smith Cyclone, HE model # BTX-80, with 90% thermal efficiency, a storage capacity of 50 gallons, an input rating of 76,000 BTU per hour, a recovery rating of 83 gallons per hour at 100°F rise and a maximum hydrostatic working pressure of 150 PSI. Water heater(s) shall be of power vent design, using 2 or 3" PVC pipe for horizontal and/or vertical vent runs.

Conservationist® Large-Volume Power Burner BTP & BTPN Gas Models

BTP-150-140 through BTP-600-2500
BTPN 150-300 through BTPN-600-2500



ASME

Complies with
SCAQMD
Rule 1146.2
California and Texas
(BTPN
Models only)

The Conservationist® high-volume power burner line includes the largest, most powerful A. O. Smith tank-type gas water heaters. With tank capacities up to 600 gallons and firing capacities up to 2.5 million BTU per hour, these large-volume high-output water heaters are capable of producing over 3,000 gallons (GPH) of hot water per hour at an 80°F rise. These heavy-duty industrial-grade water heaters are designed and built to handle the most demanding hot water heating requirements of large commercial and industrial users.

Power Gas Burner

- Suitable for natural or propane gas
- Electronic flame safeguard control with intermittent spark ignition
- Main and pilot automatic gas valves with gas pressure regulators
- Diaphragm air switch for proof of blower operation
- Flame inspection port

Fully Automatic Controls With Safety Shutoff

- High-temperature limit control (manual reset)
- CSA Certified and ASME Rated T&P Relief Valve
- Hinged-door control compartment for easy access
- Upper and lower thermostats for accurate temperature control
- Standard control is for 120°F-180°F water service
- Factory-installed low-water cutoff

Blue Diamond® Glass Lining

- Blue Diamond glass coating provides superior corrosion resistance compared to the industry-standard glass lining
- Equipped with multiple anode rods for additional corrosion protection

Heavy-Duty Jacket

- Heavy-gauge steel jacket with baked powder-coated finish for durability
- Two 3" handhole inspection openings

Maximum Hydrostatic Working Pressure

- All models: 160 PSI

Professional Start-Up Service Included

- Required for activating warranty and assuring quality performance

Codes And Standards

- Design-certified by UL (Underwriters Laboratories), according to ANSI Z21.10 standards
- Meets the thermal efficiency and standby loss requirements of the U.S. Department of Energy and current edition of ASHRAE/IESNA 90.1

Optional Low NOx Burners

- Low NOx burners from 300,000 BTUH up to 2 million BTUH
- Comply with SCAQMD Rule 1146.2 and other Air Quality Management Districts with Similar Requirements for low NOx emissions*



Conservationist® Large-Volume Power Burner BTP & BTPN Gas Models

Conservationist® BTP Options:

- Factory-approved mutual control arrangement
- 5 or 10-year extended limited warranty
- High or low water pressure switch
- AGA-rated T&P valve
- Modular graphic burner systems management on heaters with 270,000 BTU input and over
- Low NOx burner available on select models

Three-Year Limited Tank Warranty

- For complete information, consult written warranty or contact A. O. Smith

Other Conservationist® BTP Features:

- Two layers of high-temperature ceramic fiber insulation in combustion chamber
- Flame inspection port opening
- Mounted on rugged channel iron skids
- National board stamping
- ASME-rated temperature and pressure gauge
- Low-water cutoff
- Barometric draft regulator
- 120V control circuit
- Drain valve
- 180°F water service thermostats

All dimensions in inches

MODEL NO.*	GAL. CAP.	INPUT BTU/HR NATURAL GAS	FIRST HOUR DELIVERY RATING	TEMP. RISE °F-GPH RECOVERY CAPACITY			MOTOR HP 120V 60 Hz 1 PHASE	VENT SIZE	HT.	DIA.	DEPTH	SHIP WEIGHT
				80	100	140						
BTP-150-140	150	140,000	256	170	136	97	1/17 HP 2.5 AMPS	5	82-1/4	36-1/2	48	1292
BTP-150-199	150	199,000	313	241	193	138	1/17 HP 2.5 AMPS	6	82-1/4	36-1/2	48	1292
BTP-150-255	150	255,000	367	359	247	176	1/17 HP 2.5 AMPS	6	82-1/4	36-1/2	48	1292
BTP-150-270	150	270,000	382	327	262	187	1/4 HP 4.6 AMPS	6	82-1/4	36-1/2	57-1/2	1397
BTP(N)-150-400†	150	400,000	507	485	387	277	1/4 HP 4.6 AMPS	7	82-1/4	36-1/2	57-1/2	1397
BTP(N)-150-540†	150	540,000	644	654	524	374	1/4 HP 4.6 AMPS	8	82-1/4	36-1/2	57-1/2	1505
BTP-150-720	150	720,000	818	873	698	499	1/3 HP 5.5 AMPS	10	82-1/4	36-1/2	57-1/2	1510
BTP-200-300	200	300,000	451	364	291	208	1/4 HP 4.6 AMPS	6	84-1/2	44-3/4	66-1/2	2098
BTP-200-600	600	600,000	722	737	582	416	1/4 HP 4.6 AMPS	8	84-1/2	44-3/4	66-1/2	2098
BTP(N)-200-800†	200	800,000	936	970	776	554	1/3 HP 5.5 AMPS	10	84-1/2	44-3/4	66-1/2	2103
BTP(N)-200-1000†	200	1,000,000	1130	1212	970	693	1/3 HP 5.5 AMPS	10	84-1/2	44-3/4	66-1/2	2103
BTP(N)-200-1250†	200	1,250,000	1372	1515	1212	866	1/2 HP 7.4 AMPS	12	84-3/4	44-3/4	66-1/2	2467
BTP-200-1500†	200	1,500,000	1615	1818	1455	1039	1/2 HP 7.4 AMPS	12	84-3/4	44-3/4	66-1/2	2675
BTP-300-300	300	300,000	531	364	291	208	1/4 HP 4.6 AMPS	6	92	44-3/4	66-1/2	2150
BTP-300-600	300	600,000	822	727	582	416	1/4 HP 4.6 AMPS	8	92	44-3/4	66-1/2	2150
BTP(N)-300-800†	300	800,000	1016	970	776	554	1/3 HP 5.5 AMPS	10	92	44-3/4	66-1/2	2308
BTP(N)-300-1000†	300	1,000,000	1210	1212	970	693	1/3 HP 5.5 AMPS	10	92	44-3/4	66-1/2	2308
BTP(N)-300-1250†	300	1,250,000	1452	1515	1212	866	1/2 HP 7.4 AMPS	12	92	44-3/4	66-1/2	2584
BTP(N)-300-1500†	300	1,500,000	1695	1816	1455	1039	1/2 HP 7.4 AMPS	12	92	44-3/4	81-1/2	2774
BTP-400-600	400	600,000	902	727	582	416	1/4 HP 4.6 AMPS	8	89	55	76-1/2	3207
BTP(N)-400-800†	400	800,000	1096	970	776	554	1/3 HP 5.5 AMPS	10	89	55	76-1/2	3212
BTP(N)-400-1000†	400	1,000,000	1290	1212	970	693	1/3 HP 5.5 AMPS	10	89	55	76-1/2	3212
BTP(N)-400-1250†	400	1,250,000	1532	1515	1212	866	1/3 HP 5.5 AMPS	12	89	55	76-1/2	3212
BTP(N)-400-1500†	400	1,500,000	1775	1816	1455	1039	1/2 HP 7.4 AMPS	12	89	55	91-1/2	3402
BTP(N)-400-1750†	400	1,750,000	2017	2121	1697	1212	1/2 HP 7.4 AMPS	14	89	55	91-1/2	3528
BTP(N)-400-2000†	400	2,000,000	2259	2424	1939	1385	1/2 HP 7.4 AMPS	14	96-1/4	55	91-1/2	3669
BTP-500-2250	500	2,250,000	2582	2727	2182	1558	3/4 HP 10.2 AMPS	16	108	55	91-1/2	4277
BTP-500-2500	500	2,500,000	2824	3030	2424	1732	3/4 HP 10.2 AMPS	16	108	55	91-1/2	4419
BTP-600-720	600	720,000	1178	873	698	499	1/3 HP 5.5 AMPS	10	114	55	76-1/2	3667
BTP(N)-600-1000†	600	1,000,000	1450	1212	970	693	1/3 HP 5.5 AMPS	10	114	55	76-1/2	3667
BTP(N)-600-1250†	600	1,250,000	1692	1515	1212	866	1/3 HP 5.5 AMPS	12	114	55	76-1/2	3667
BTP(N)-600-1500†	600	1,750,000	1935	1816	1455	1039	1/2 HP 7.4 AMPS	12	114	55	91-1/2	3837
BTP(N)-600-1750†	600	1,750,000	2177	2121	1697	1212	1/2 HP 7.4 AMPS	14	114	55	91-1/2	3837
BTP(N)-600-2000†	600	2,000,000	2419	2424	1939	1385	1/2 HP 7.4 AMPS	14	114	55	91-1/2	3837
BTP-600-2250	600	2,250,000	2662	2727	2182	1558	3/4 HP 10.2 AMPS	16	114	55	91-1/2	4477
BTP-600-2500	600	2,500,000	2904	3030	2424	1732	3/4 HP 10.2 AMPS	16	114	55	91-1/2	4619

†Models with an (N) are available in low NOx (include the "N" in the model number when ordering).

*After January 1, 2012, Models will not meet SCAQMD Rule 1146.2 requirements for low NOx emissions.

Power Burner Water Heaters Conservationist® Models

Power burner models provide thermal efficiencies of 80%

These gas power burner models provide an outstanding thermal efficiency of 80% or more and are suitable for commercial applications.



ASME

Standard on BTPN-140 thru 500, 540, 650 & 700 models



Complies with SCAQMD Rule 1146.2



(BTPN & BTPV Models only)

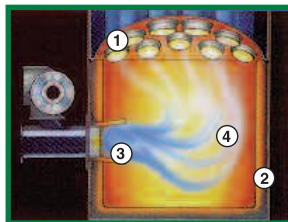

Small Volume BTP Quality Features:

- UL listed power burner
- ASME construction
- CSA Certified and ASME rated T&P relief valve
- Handhole cleanout(s) for easy maintenance
- Three-year limited tank warranty
- Fully automatic controls ensure safe, efficient operation
- Barometric draft damper ensures correct airflow in the vent
- Factory Start-up Included, required for activating warranty and assuring quality performance
- Mounted on rugged channel iron skids for easy transport during installation
- Multiple anodes for extra protection against tank corrosion
- Flame inspection port opening for visual inspection of flame characteristics during operation
- Spark pilot ignition
- Factory-installed burner for easy installation
- Complies with SCAQMD rule 1146.2 and other Air Quality Management Districts with similar requirements for low NOx emissions
- Meets the Thermal efficiency and standby loss requirements of the U.S. Department of Energy and current edition of ASHRAE/IESNA90.1
- Contact Canadian customer service for availability in Canada
- 3-year limited tank warranty

Options (Not Available On All Models)

- 5-year limited tank warranty
- 3 vent options: atmospheric, sidewall and direct vent

Shown here is the power burner combustion chamber used in the BTP-540A, BTP-650A & BTP-740A models. These models can vent through a side wall up to 100 ft. without an external blower.

1. **Exclusive PermaGlas® Ultra Coat™ Glasslined Tank** protects tank surfaces and all welds from the corrosive effects of hot water.
2. **Proylite 3100 Chamber Wall** retains heat, ensuring cool operation and maximum heat transfer to water, not the room.
3. **Premix Combustion System** provides super clean low-NOx flame. Helps eliminate hot spots and uneven heat transfer.
4. **Sealed Combustion Chamber** reduces heat loss.

All dimensions in inches

MODEL NO.+	GAL. CAP.	FIRST HOUR DELIVERY RATING	RECOVERY CAPACITY/GPH 100°F RISE	VENT SIZE	INPUT BTU/HR. NATURAL GAS	HT.	DIA.	APPROX SHIP WEIGHT
BTP-139	86	196	136	6	140,000	74 3/4	27 3/4	556
BTP-199	86	253	193	6	199,000	74 3/4	27 3/4	545
BTP-270	86	268	262	8	270,000	74 3/4	27 3/4	547
BTP-370	75	412	359	8	370,000*	74 3/4	27 3/4	634
BTP-139A	86	196	136	6	140,000	74 3/4	27 3/4	658
BTP-199A	86	253	193	6	199,000	74 3/4	27 3/4	635
BTP-270A	86	322	262	8	270,000	74 3/4	27 3/4	632
BTP-370A	75	412	359	8	370,000*	74 3/4	27 3/4	731
BTP(V)-540A*	85	583	523	9	540,000	93	29 1/2	950
BTP(V)-650A*	85	690	630	9	650,000	93	29 1/2	950
BTP(V)-740A*	85	778	718	9	740,000	93	29 1/2	950

*Available with optional horizontal sidewall or sealed direct vent termination kits (specified at time of order).

+After January 1, 2012, Models will not meet SCAQMD Rule 1146.2 requirements for low NOx emissions.



COF models provide thermal efficiencies of 80%

Conservationist® Duraclad Oil-Fired Small Volume Models

Our Duraclad COF-199 and larger models have an optional two-stage pump for use with below-grade oil storage tanks. Features include two handhole clean-outs for easy servicing. The large volume COBT models are available as a dual-fuel heater—natural gas as well as oil-fired.

Small Volume COF Quality Features:

- For small to medium-sized applications
- UL listed oil burner
- 180°F adjustable thermostat
- Single-stage oil pump for simple, efficient operation.
- Solenoid oil valve (standard on 455, 700)
- 3/4" drain valve
- CSA Certified and ASME rated T&P relief valve
- Two handhole clean-outs (COF-385 and larger, and ASME models) for easy maintenance.
- Barometric draft regulator provided for proper operation, ensures correct flow in the vent
- Foam insulation
- Intermittent ignition
- CoreGard™ anode rod with stainless steel core won't corrode, won't break off
- Flame observation port
- PermaGlas® glasslined tank with 160 PSI maximum working pressure
- 3-year limited tank warranty

Options

- Two-stage pump for use with underground oil storage tanks
- Oil solenoid safety valve
- ASME construction available on models COF-315 and larger
- 5-year limited tank warranty



ASME

Available on COF-315 and higher

All dimensions in inches

MODEL NO.	GAL. CAP.	BTU INPUT PER HOUR	FIRST HOUR DELIVERY RATING*	TEMP. RISE DEG. R-GPH			HT.	DIA.	DEPTH	SHIP WEIGHT	
				40	100	140				STD	ASME
COF-199	86	199,000	253	482	193	138	74-3/4	24-3/4	37	553	NA
COF-245	86	245,000	298	594	238	170	74-3/4	24-3/4	37	554	NA
COF-315	84	315,000	364	764	305	218	74-3/4	24-3/4	37	554	657
COF-385	75	385,000	426	933	373	267	74-3/4	24-3/4	37	624	742
COF-455	75	455,000	494	1103	441	315	74-3/4	24-3/4	37	700	747
COF-700	69	700,000	727	1697	679	485	79-1/2	24-3/4	37	739	822

*Based on No. 2 fuel oil.

All models have 1/8 HP motor.

Add "S" to the end of the model number for standard (COF-199S) and "A" to the end of the model number for ASME (COF-700A) tanks.

Heavy-Duty Oil-Fired COF/COBT Models

Large Volume High Output Oil and Dual Fuel Water Heaters



Conservationist® COF models offer oil fuel burners (No. 1 or 2 oil). COBT models feature combination gas/oil powered burners for the versatility of operating with natural gas/propane and No. 1 or 2 oil. Conservationist COF/COBT models include some of the largest and most powerful A. O. Smith tank-type water heating systems available – with storage/input options up to 600 gallons/2,500,000 BTU/hour and recoveries as high as 2,424 gallons/hour at 100°F rise. All models feature fully automatic controls with safety shutoff, two thermostats (upper and lower) for accurate temperature control, and ASME tank construction.

COF (Oil-Fired Models)

- Use either No. 1 or 2 fuel oil
- 3450 rpm motor
- Multi-annular fuel containment combustor head
- Oil ignition transformer
- Integral 2-stage fuel unit and oil safety valve

COBT (Combination Gas/Oil-Fired Models)

- Use either natural gas or propane and No. 1 or 2 fuel oil
- 3450 rpm motor
- Multi-annular fuel containment combustor head
- Gas/electric pilot and gas ignition transformer
- Pilot and main pressure regulators
- Air safety switch
- Manual fuel-selector switch
- Integral two-stage fuel unit

Fully Automatic Controls With Safety Shutoff

- High temperature limit control (manual reset)
- CSA Certified and ASME rated T&P relief valve
- Hinged-door control compartment for easy access
- Upper and lower thermostats for accurate temperature control

Blue Diamond® Glass Lining

- Blue Diamond coating provides superior corrosion resistance compared to industry-standard glass lining
- Equipped with multiple anode rods for additional corrosion protection

Heavy-Duty Jacket

- Heavy gauge steel jacket with baked powder-coated finish for durability
- Two 3" handhole inspection openings

Maximum Hydrostatic Working Pressures

- All COF and COBT models: 160 PSI

Compliance

- Meets the Thermal efficiency and standby loss requirements of the U.S. Department of Energy and current edition of ASHRAE/IESNA90.1

Professional Start-Up Service Included

- Required for activating warranty and assuring quality performance



Two Layers Of High Temperature Ceramic Fiber Insulation In Combustion Chamber

Flame Inspection Port Opening

Mounted On Rugged Channel Iron Skids

ASME Stamping

Low-Water Cutoff

3-Year Tank Limited Warranty

Conservationist COF/COBT Options

- Factory mutual approved control arrangement
- 5-year or 10-year extended limited warranty
- High or low water pressure switch
- 180°F water service thermostats
- CSA certified and ASME rated T&P relief valve
- Modular graphic burner systems management on heaters with 270,000 BTU input and greater

All dimensions in inches

MODEL NO.	GAL. CAP.	INPUT BTU/HR	OIL FLOW RATE	FIRST HOUR DELIVERY RATING	TEMP. RISE °F-GPH RECOVERY CAPACITY			COBT MOTOR HP 1 Ø 120V	COF MOTOR HP 1 Ø 120V	VENT SIZE	HT.	DIA.	DEPTH	SHIP WEIGHT		
					80	100	140									
COF-150-140	150	140,000	1	241	170	136	97	1/3 HP, 5.5 AMPS	1/7 HP, 4.4 AMPS	5	82-1/4	36-1/2	47	1292		
COF-150-199	150	199,000	1.4	298	241	193	138			6	82-1/4	36-1/2	47	1292		
COF-150-255	150	255,000	1.8	352	359	247	176			6	82-1/4	36-1/2	47	1292		
COF-150-270	150	270,000	1.9	367	327	262	187	1/3 HP 5.5 AMPS	1/4 HP, 4.6 AMPS	6	82-1/4	36-1/2	57-1/2	1397		
COBT-150-350	150	350,000	2.2	444	420	339	242			7	82-1/4	36-1/2	57-1/2	1397		
*COF/COBT-150-400	150	400,000	2.8	452	485	387	277			7	82-1/4	36-1/2	57-1/2	1397		
COF/COBT-150-540	150	540,000	3.8	629	654	524	374			8	82-1/4	36-1/2	57-1/2	1505		
COF/COBT-150-720	150	720,000	5.1	803	873	698	416		10	82-1/4	36-1/2	57-1/2	1510			
*COF/COBT-200-300	221	300,000	2.1	446	354	291	208		6	84-1/2	44-3/4	66-1/2	2098			
COF/COBT-200-600	221	600,000	4.2	737	727	582	416		1/3 HP, 5.5 AMPS	1/3 HP, 5.5 AMPS	8	84-1/2	44-3/4	66-1/2	2098	
COF/COBT-200-800	221	800,000	5.7	931	970	776	554				10	84-1/2	44-3/4	66-1/2	2103	
COF/COBT-200-1000	201	1,000,000	7.1	1111	1212	970	866				10	84-1/2	44-3/4	66-1/2	2103	
COF/COBT-200-1250	201	1,250,000	8.9	1353	1515	1212	866		3/4 HP 10.2 AMPS	1/3 HP, 5.5 AMPS	12	84-3/4	44-3/4	66-1/2	2467	
COF/COBT-200-1500	201	1,500,000	10.7	1560	1818	1455	1039	12			84-3/4	44-3/4	81-1/2	2675		
*COF/COBT-300-300	300	300,000	2.1	501	364	291	208	6			92	44-3/4	66-1/2	2150		
COF/COBT-300-600	300	600,000	4.2	792	727	582	416	8			92	44-3/4	66-1/2	2150		
COF/COBT-300-800	300	800,000	5.7	986	970	776	554	10			92	44-3/4	66-1/2	2308		
COF/COBT-300-1000	300	1,000,000	7.1	1180	1212	970	693	10	92	44-3/4	66-1/2	2308				
COF/COBT-300-1250	300	1,250,000	8.9	1422	1515	1212	866	3/4 HP, 10.2 AMPS		12	92	44-3/4	66-1/2	2584		
COF/COBT-300-1500	300	1,500,000	10.7	1665	1816	1455	1039	1/3 HP 5.5 AMPS	1/3 HP, 5.5 AMPS	12	92	44-3/4	81-1/2	2774		
COF/COBT-400-600	411	600,000	4.2	870	727	582	416			8	89	55	76-1/2	3207		
COF/COBT-400-800	411	800,000	5.7	1064	970	776	554			10	89	55	76-1/2	3212		
COF/COBT-400-1000	411	1,000,000	7.1	1258	1212	970	693	3/4 HP 10.2 AMPS		10	89	55	76-1/2	3212		
COF/COBT-400-1250	411	1,250,000	8.9	1500	1515	1212	866			12	89	55	76-1/2	3212		
COF/COBT-400-1500	397	1,500,000	10.7	1733	1816	1455	1039			12	89	55	91-1/2	3402		
COF/COBT-400-1750	397	1,750,000	12.5	1975	2121	1697	1212			14	89	55	91-1/2	3528		
COF/COBT-400-2000	397	2,000,000	14.2	2217	2424	1939	1385	1 HP 16 AMPS		14	96-1/4	55	91-1/2	3669		
COF/COBT-500-2250	375	2,250,000	16.0	2445	2727	2182	1558	1/3 HP 5.5 AMPS	1/3 HP, 5.5 AMPS	16	108	55	91-1/2	4277		
COF/COBT-500-2500	375	2,500,000	17.8	2687	3030	2424	1732			16	108	55	91-1/2	4419		
COF/COBT-600-720	594	720,000	5.1	1114	873	698	499			10	114	55	76-1/2	3667		
COF/COBT-600-1000	594	1,000,000	7.1	1386	1212	970	693	3/4 HP 10.2 AMPS		10	114	55	76-1/2	3667		
COF/COBT-600-1250	594	1,250,000	8.9	1627	1515	1212	866			12	114	55	76-1/2	3667		
COF/COBT-600-1500	594	1,500,000	10.7	1871	1816	1455	1039			12	114	55	91-1/2	3837		
COF/COBT-600-1750	594	1,750,000	12.5	2116	2121	1697	1212			14	114	55	91-1/2	3837		
COF/COBT-600-2000	594	2,000,000	14.3	2355	2424	1939	1385			1 HP 16 AMPS		14	114	55	91-1/2	3837
COF/COBT-600-2250	575	2,250,000	16.0	2585	2727	2182	1558			1 HP 16 AMPS		16	114	55	91-1/2	4477
COF/COBT-600-2500	575	2,500,000	17.8	2827	3030	2424	1732	16	114			55	91-1/2	4619		

*COBT models are 350,000 BTU

Air-to-Water Electric Heat Pump AWH Series

Electric Heat Pumps



Air-to-Water heat pump water heaters remove unwanted heat and humidity from the surrounding air and use it to heat water. The refrigeration-based system produces cool, dehumidified air for spot cooling or to reduce the load on air conditioning system.

Air-to-Water Heat Pump Water Heater Options:

- High Efficiency water heating
- "Environmentally-Friendly" Green Technology uses non-ozone depleting R-134a refrigerant
- Simplified Installation
- Efficient Scroll Compressor
- Coefficient of Performance (COP) between 3.9 and 4.2 for water heating
- Standard 208/230 VAC, 3 phase power (optional 460 VAC, 3 phase)
- Sanitary hot water for commercial or industrial uses
- Maximum 140°F final tank temperature at common indoor temps

Accessories Include:

- Digital Temp Controller with Tank Probe
- Metal Mesh Cleanable Filter
- Corrosive Duty Package; 316 stainless steel cabinet polyurethane coated evaporator coil and blower housing. Recommended for coastal areas.

All dimensions in inches

MODEL NUMBER	PERFORMANCE					DIMENSIONS				APPROXIMATE SHIPPING WEIGHT (LBS.)
	WATER HEATING BTUH*	COOLING CAPACITY BTUH*	AIR VOLUME CFM**	C.O.P.	G.P.M.	INLET/OUTLET (FPT)	WIDTH	DEPTH	HEIGHT	
AWH-35	35,500	27,500	1040	3.9	7	1.0"	40"	26"	24-3/4"	315
AWH-55	58,000	45,500	1650	4.1	11	1.0"	47"	32"	28-1/2"	405
AWH-75	76,000	59,000	2150	3.9	15	1.5"	57"	32"	28-1/2"	485
AWH-100	98,000	78,000	3200	4.2	20	1.5"	63"	38"	42-1/2"	660
AWH-115	113,000	89,000	3200	4.2	23	1.5"	63"	38"	42-1/2"	665
AWH-140	142,000	110,000	3800	3.9	28	2.0"	63"	38"	42-1/2"	725
AWH-170	171,000	133,000	4900	3.9	34	2.0"	75"	46"	42-1/2"	880

*Performance rating at 75° F, 55% Relative Humidity and 100° incoming water temperature

**Blower design at 0.3" external static pressure

C.O.P. coefficient of performance

All models standard 208/230V, 3-phase, 60 Hz

Optional 460v 3ph 60Hz

Optional 240v 1ph 60Hz (available on AWH-35 and AWH-55 only)





DEN/DEL Electric Dura-Power™ Models



The Dura-Power™ DEN (standard upright) and DEL (lowboy) series is available with tank capacities from 6 through 119-gallons. They can be installed for non-simultaneous and single element operation (maximum input up to 6 KW), or for simultaneous dual-element operation (maximum input up to 12 KW).

Zinc-Plated Copper Sheath Heating Elements Standard

- Medium-watt density design disperses element temperature over larger surface contact area to minimize scale build-up, maximize efficiency and prolong element life
- Element options from 1.5 kW to 6 kW (non-simultaneous or simultaneous operation), recovers from 6 GPH to 49 GPH at 100°F rise

Standard Voltages For Easy Installation

- 120V, 277V single-phase, and 208V, 240V and 480V unbalanced 3-phase delta
- Easily converted to single-phase at terminal block (except for 208V with 6000W elements)
- Single-element heater, single-phase only (see chart for dual-element options)

Factory-Installed Terminal Block

- Provide electrical service to heater and connect to block (not supplied on 120V and 277V models)

Factory-Wired Controls

- Temperature control (adjustable from 110°F to 170°F on single element; 120°F to 180°F on dual-element models)
- Manual reset high temperature cutoff per element (dual-element models)
- Factory-wired for non-simultaneous operation; easily converted to simultaneous operation (3-phase models only)

Glasslined Tank

- Provides long-lasting protection against corrosion
- Equipped with anode rod for additional protection against corrosion

Compliance

- Meets the standby loss requirements of the U.S. Department of Energy and current edition of ASHRAE/IESNA90.1

Maximum Hydrostatic Working Pressure: 150 PSI

3-Year Limited Tank Warranty

- 5-year limited tank warranty optional

All dimensions in inches

MODEL NO	GAL . CAP.	KILOWATTS MAXIMUM	HEIGHT	DIA.	APPROX SHIP WEIGHT
DEL MODELS					
DEL-6S	6	2.5	15-1/2	14-1/4	35
DEL-10S	10	6	18-1/4	18	52
DEL-15S	15	6	26	18	66
DEL-20S	20	6	22-1/4	21-3/4	86
DEL-30D	30	12	30-7/8	21-3/4	104
DEL-40D	40	12	32-1/4	24	170
DEL-50D	50	12	32-1/4	26-1/2	166
DEN MODELS					
DEN-30D	30	10	34-1/2	20-1/2	95
DEN-40D	40	12	45-1/8	20-1/2	110
DEN-52D	50	12	54-7/8	20-1/2	128
DEN-66D	66	12	60-3/4	21-3/4	167
DEN-80D	80	12	59-3/8	24	206
DEN-120D	119	12	62-7/16	29-3/8	331

*S denotes Single Element D denotes Dual Element



DRE/DVE Electric Gold and Gold Xi

Gold and Gold Xi DRE/DVE series available with 50, 80, and 119 gallon storage tanks, with input choices ranging from 6 kW to 54 kW. They can be used as recovery heaters for hot water supply service or as boosters for supplying sanitizing rinse water for dish washing.

Goldenrod® 24k gold-plated Elements Standard

- Superior scaling resistance, resulting in long term efficiency and damage protection
- Element sizes from 2 kW to 6 kW using 3, 6 or 9 elements provide input options from 6 kW to 54 kW, recovers from 25 GPH to 221 GPH at 100°F rise

Power Circuit Fusing For System Protection

- Safeguards elements and contactors from short circuits, overloading and line surges
- Meets National Electrical Code requirements that non-ASME tanks must have internal fusing when current draw exceeds 48 amps

208, 240 and 480V Options For Easy Installation

- Single-phase and 3-phase delta
- Field-convertible voltages 3-phase to single-phase (and vice versa) except for 208V/54 kW
- 277V single-phase also available

Factory-Installed Terminal Block

- Provide electrical service to heater and connect to block

Heavy-Duty Magnetic Contactors (DVE Models Only)

- UL-rated 100,000 cycles

Other Standard DRE/DVE Features

- Two anode rods for maximum corrosion protection
- Simplified circuitry, color coded for ease of service

- Bonderized undercoated baked enamel finished cabinets
- Brass Drain Valve
- CSA/ASME temperature and pressure relief valve

DRE Gold Model Controls

- DRE Gold models have surface mount temperature controls adjustable 120° to 180°F.
- Manual reset high-temperature cutoff

DVE Gold Xi Model Features

Advanced Electronic Controls

- iCOMM™ Compatible and can be monitored from remote locations. Call 1.888.WATER02 for more information.
- Plain English text and animated icons.
- Displays detailed operational and diagnostic information
- Fault or alert messages appear if an operational issue occurs
- Last 9 fault and alert messages saved with time stamp.

Economy Mode Operation

- Control system automatically lowers the operating set point by a programmed value during user-defined time periods
- Helps reduce operating costs during unoccupied or low demand periods

Precise Temperature Regulation

- Operating Set Point adjustable 90° to 190°F

- Banks of heating elements (3 elements per bank) are energized according to adjustable (1° to 20°) differential set points for each bank. Helps reduce short cycling and operating costs by matching kW output to load conditions
- Linear sequencing - first bank on is last bank off
- Helps reduce current surge/spikes and avoid peak demand charges
- Helps reduce operating costs during low load conditions
- Manual reset high-temperature cutoff

Compliance

- Meets the standby loss requirements of the U.S. Department of Energy and current edition of ASHRAE/IESNA90.1

3-Year Limited Tank Warranty

- 5-year limited tank warranty optional



DVE Model

DRE Model

All dimensions in inches

MODEL NO.	GAL. CAP.	KILOWATTS MAXIMUM	HEIGHT	DIA.	APPROX. SHIP WEIGHT	
					STD.	ASME
DVE/DRE-52	50	54	55-3/4	21-3/4	265	316
DVE/DRE-80	80	54	60-1/4	25-1/2	280	325
DVE/DRE-120	119	54	62-1/4	29-1/2	390	416

See specification sheets or contact your local rep for optional KW's available.



(DVE Models Only)



ASME (Optional)

Heavy-Duty Custom Xi Electric DSE Models

The heavy-duty Custom Xi DSE series is available with storage capacities from 5 to 119 gallons. All tanks feature ASME tank construction. With input choices as high as 90 kW on 50 through 119 gallon models, the DSE Custom Xi series can be used for maximum-demand hot water supply service or as boosters for supplying sanitizing rinse water for dish washing.

Incoloy Sheath Heating Elements Standard

- Industrial-grade Incoloy sheathed heating elements are designed for rugged long-lasting commercial service, and can withstand sheath temperatures up to 1500°F
- Each heating element has three separate heating loops, which provides more heating surface, lower watt density and maximum recovery efficiency
- Prewired leads provide excellent protection against oxidation and scaling
- Input options from 3 kW to 90 kW, recoveries from 12 GPH to 369 GPH at 100°F rise

Standard Voltages For Easy Installation

- Single-phase and 3-phase
- Single-phase 208V and 240V are field-convertible to 3-phase
- All 208V and 240V at 24 kW and below are supplied as phase-convertible units (single-to 3-phase and vice versa)
- 277V single-phase also available (Contact A. O. Smith for 120V circuit availability)
- International voltages also available (check with factory)

Factory-Installed Terminal Block (units with more than one contactor)

Advanced Electronic Controls

- iCOMM™ Compatible and can be monitored from remote locations. Call 1.888.WATER02 for more information.
- Plain English text and animated icons
- Displays detailed operational and diagnostic information
- Fault or alert messages appear if an operational issue occurs.
- Last 9 fault and alert messages saved with time stamp.

Progressive Sequencing

- First heating element on is first heating element off.
- First heating element energized is rotated with each successive heating cycle on models with multiple heating elements.
- Evens out wear between heating elements.

Economy Mode Operation

- Control system automatically lowers the operating set point by a programmed value during user-defined time periods.
- Helps reduce operating costs during unoccupied or low demand periods

Precise Temperature Regulation

- Operating Set Point adjustable 90° to 190°F.
- Sequencing - Units with multiple element contactors are sequenced on with one second delay between stages. Adjustable modulating mode is optional.
- Helps reduce current surges/spikes and avoid peak demand charges.
- Manual reset high temperature cutoff.

Heavy-Duty Magnetic Contactors

Power Circuit Fusing For System Protection

Glasslined Tank, with ASME Construction

CSA Certified and ASME Rated T&P Relief Valve

Compliance

- Meets the standby loss requirements of the U.S. Department of Energy and current edition of ASHRAE/IESNA90.1

Brass Drain Valve

3-Year Limited Tank Warranty

- 5-year limited tank warranty optional



ASME



Optional Goldenrod® 24-carat gold-plated elements resist lime scale adhesion and sheath temperatures up to 1500° F.

All dimensions in inches

MODEL NO.	GAL. CAP.	MAXIMUM		HEIGHT	DIA.	APPROX. SHIP WEIGHT
		KILOWATTS	IMMERSION HEATERS			
DSE-5	5	3	1	20-1/2	16-1/4	100
DSE-10	10	6	1	26-1/2	18-3/4	116
DSE-20	20	18	2	27-1/4	20-1/2	145
DSE-30	30	24	2	35-3/4	20-1/2	168
DSE-40	40	36	2	45-3/4	20-1/2	206
DSE-50	50	90	5	54-3/4	20-1/2	235
DSE-65	65	90	5	50-1/2	26-1/2	280
DSE-80	80	90	5	49-1/4	28	300
DSE-100	100	90	5	58-1/4	28	354
DSE-120	119	90	5	63-1/4	30	430



Heavy-Duty CMC/SU Booster Electric Dura-Power™ Models

The Dura-Power™ commercial electric water heaters are designed to boost the water temperatures for applications such as commercial dishwashers, which require very high temperature sanitizing rinse...typically 180°F. Both 5-gallon countermount CMC models and 20-gallon SU models are available with inputs up to 54 kW. All models are also available with an optional stainless steel tank, for use with deionized water.

Incoloy-Sheath Heating Elements Standard

- Industrial-grade Incoloy sheathed heating elements are designed for rugged long-lasting commercial service and can withstand sheath temperatures up to 1500°F
- Each heating element has three separate heating loops, which provides more heating surface, lower watt density and maximum recovery efficiency
- Pre-wired leads provide excellent protection against oxidation and scaling
- Input options from 6 kW to 54 kW recovers from 62 GPH to 554 GPH at 40°F rise
- Deionized models equipped with stainless steel standard elements

A. O. Smith Goldenrod® Elements Optional

- Patent-pending 24K gold-plated sheath plus medium-watt density ensures even longer element life
- 600% higher resistance to scale build-up, compared to Incoloy elements
- Three-year warranty against failure due to lime scale build-up
- Not available on deionized models

Standard Voltages For Easy Installation

- Single-phase and 3-phase
- Single-phase 208V and 240V are field-convertible to 3-phase
- CMC models only, 208V and 240V at 24kW and below are supplied as phase-convertible units (single- to 3-phase and vice versa)
- 277V single-phase also available (Contact A. O. Smith for 120V circuit availability)

Immersion Thermostat For Efficient Control

- Close differential, immersion-type thermostat for superbly accurate temperature control
- Adjustable from 140°F to 185°F
- Manual reset, high-temperature cut-off

Power Circuit Fusing For System Protection

- Safeguards elements and contactors from short circuits, overloading and line surges
- Required by National Electric Code and UL when current draw exceeds 120A

Heavy-Duty Magnetic Contactors

- UL-rated 100,000 cycles

Factory-Wired 120V Circuit Controls

- 120V control circuit powered by fused transformer
- Eliminates need for 120V service connection

Compliance

- Meets the standby loss requirements of the U.S. Department of Energy and current edition of ASHRAE/IESNA90.1



ASME

Optional Goldenrod® 24-carat gold-plated elements resist lime scale adhesion and sheath temperatures up to 1500°F.



All dimensions in inches

MODEL NO.	GAL. CAP.	NO. OF IMMERSION HEATERS	INLET/OUTLET	HT.	WIDTH	DEPTH	APPROX. SHIP WEIGHT
CMC-6 thru 18	5	1	3/4	13-3/4	13	21-3/4	80
CMC-20 thru 54	5	2*	3/4	12	18	22-1/2	96
SU-6 thru 18	20	1	3/4	25	22-1/4	23	200
SU-20 thru 54	20	2*	3/4	25	22-1/4	23	200

*CMC-54 and SU-54 have three immersion heaters.

Heavy-Duty Premium Electric DVE/DHE Dura-Power™ Models



ASME



Optional Goldenrod®
24-carat gold-plated
elements resist lime
scale adhesion and
sheath temperatures
up to 1500° F.

Dura-Power™ commercial electric water heaters are built to the same high-quality standards as our gas models. These are the largest commercial electric's we manufacture. Ideal for use as recovery heaters for all types of large commercial and industrial applications or for large process potable hot water requirements. They can be customized to meet any special application with the large selection of available options.

Advanced Electronic Control (All Models 150 kW and Down)

A. O. Smith's new propriety electronic water heater control, provides precise + or - 1°F temperature control, that is ideal for industrial and food service applications where exact temperatures of hot water are needed.

- **Plain Text** – Animated icons display detailed operational and diagnostic information. Fault or Alert messages appear if an operational issue occurs.
- **Low Water Cut Off** – Factory standard on board low water cut-off uses a remote electronic immersion type probe to prevent energizing of the elements in the event of low water condition and eliminates accidental dry firing.
- **Progressive Modulating (only available on units 150 kW or less)** – Sizes the input of available elements to match current load conditions. Rotates and lead lags element loads to provide long life and equal wear.
- **Economy Mode Operation (only available on units 150 kW or less)** – Control system automatically lowers the operating set point by a programmed value during user defined time periods. Seven-day clock may be programmed for night set back and or weekend shutdown to reduce operating cost and save money.
- **iCOMM™ Compatible** – Units can be monitored from remote locations. Call 1.888.WATER02 for more information. Note: Up to 150 kW only. Units above 150 kW use analog controls.

Solid State Modulating Step Control (All Models 180 kW and up)

- Solid state electronic control device that modulates input to match load through progressive sequencing of steps (up to 20 steps with maximum of one per contactor).

Glasslined Tank

- Tank interior is coated with glass specially developed for use in water heaters. Tanks rated at 125 psi working pressure; 150 psi or 160 psi working pressure is optional. Vermin proof fiber glass insulation reduces costly heat loss. Constructed to Section IV of ASME code, and UL standards. Tanks have channel skid base. A 4" x 6" handhole is furnished on 500, 600 and 700-gallon models; 11" x 15" manhole is furnished on 800-gallon and larger sizes.

Incoloy Immersion Heaters

- Heavy-duty medium watt density elements (three immersion heater) have incoloy sheathing; provide excellent protection against oxidation and scaling. The input ranges from 15kW to 3000kW.

Fusing

- Control and power circuit fusing to meet N.E.C.

Compliance

- Meets the standby loss requirements of the U.S. Department of Energy and current edition of ASHRAE/IESNA 90.1.

Magnetic Contactor(s)

- Heavy duty UL rated for 100,000 cycles.

Other Standard Features

- Color-coded circuitry for easier servicing
- Anode rods for maximum corrosion protection
- Standard voltages include 208, 240, 480, 600 volt single or three-phase.
- For other voltages consult factory.
- Factory-installed terminal block(s)
- Cabinet has baked enamel finish
- Rewired element terminal leads
- Temperature and pressure relief valve
- 2" dial temperature gauge

Optional Dual-Energy Source Capability

- Provides emergency back up energy source or winter/summer boiler operation. Can be specified with optional water to water or steam to water heat exchangers. Both single and double wall heat exchangers are available. Complete control packages can be factory-installed for hook up and run capability.

Limited Warranty Outline

- 3-Year Limited Tank Warranty
- Optional 5-Year Limited Tank Warranty
- If the tank should leak any time during the first three years, under the terms of the warranty, A. O. Smith will repair or replace the heater; installation, labor, handling repair or replace the heater; installation, labor, handling and local delivery extra. THIS OUTLINE IS NOT A WARRANTY. For complete information, consult the written warranty or A. O. Smith Water Products Company. Warranty does not apply to product installed outside of the United States of America or its territorial possessions and Canada.



Options

■ Tank Linings

CEMENT – A special formulation of cement providing excellent corrosion protection. Available on 200-gallon and larger tanks.

EPOXY – A solventless two component epoxy lining applied to a minimum ten-mil (.010”) dry thickness. Available on 200-gallon and larger tanks.

■ **GOLDENROD® ELEMENTS** – Available with Optional Goldenrod® Elements - All DVE/DHE models are available with the Goldenrod® 24K gold plated elements (patent pending). Goldenrod® Elements provide long-life and five times the scaling resistance of standard incoloy elements. Goldenrod® Elements carry a three-year warranty against failure due to scale buildup.

■ **SPECIAL CONSTRUCTION** – Silicon Bronze Vessels are available for special applications or very corrosive water conditions. Consult factory for specific sizes.

■ **STAINLESS STEEL VESSELS** – Are available for deionized water. Built with stainless steel under rules of Section IV of the ASME Boiler and Pressure Vessel Code for operation on deionized water having a minimum specific resistivity of 10 megohm/cm.

■ **150 OR 160 PSI WORKING PRESSURE** – Must be specified at time of order.

Other Optional Features

■ **TEMPERATURE AND PRESSURE RELIEF VALVES** – For working pressures other than standard; consult factory.

■ **HORIZONTAL OR VERTICAL** – See specifications, most gallon capacities may be obtained in vertical or horizontal construction.

■ **CIRCULATING PUMP PACKAGE** – Circulating pump and piping sized to turn over entire storage capacity of tank once each hour. Recommended to optimize available water at temperature in horizontal tanks particularly where low draw conditions are anticipated.

■ **OPTIONAL INTERNATIONAL VOLTAGES** – 380 and 415 volts three-phase.

■ **3-1/2” DIAL-TYPE PRESSURE GAUGE** – Factory-installed.

■ **3-1/2” DIAL-TYPE TEMPERATURE GAUGE** – Factory-installed.

■ **11” x 15” MANHOLE** – Available as option on tanks 700 gallons or smaller.

Control Options

■ **COPPER TUBE TANK HEATER** – Double wall copper tube tank heaters are designed for heating potable water with both potable or non-potable liquids or steam, and are specifically engineered for installation in models DVE and DHE for dual-energy applications. Tank heaters have a positive fail-safe means of leak detection in the event of either tube failure to prevent mixture of heating medium and potable water. Singlewall heat exchangers are also available.

■ **TERMINAL BLOCKS** – Allows for remote connection to building demand limiter or other functions.

■ **AUTOMATIC RESET HIGH LIMIT** – A control that in the event of high temperature, interrupts power, de-energizing elements, automatic reset. (Standard with modulating step control).

■ **INDICATING LIGHTS** – Denotes heating stage(s) in operation. Up to one light per contactor is available.

■ **OVERRIDE SWITCHES** – A simple means of load control allows all or part of unit input to be controlled manually. Up to one switch per contactor is available

■ **SAFETY DOOR INTERLOCK** – Prevents opening of control panel door when heater power supply is on. NOTE: Once door is opened heater may be energized if necessary for service diagnosis.

■ **SHUNT TRIP CIRCUIT BREAKER** – A safety device (circuit breaker) which disconnects power to heater in the event of over-current, high temperature or low water level, breaker must be manually reset.

■ **CIRCUIT BREAKER** – A safety device which disconnects power to the heater in the event of overcurrent.

All dimensions in inches

VERTICAL ELECTRIC STORAGE HEATERS					
MODEL NO.	GAL. CAP.	MAX KW INPUT	HEIGHT	WIDTH	DEPTH
DVE-140	125	120	83-1/2	30	37
DVE-150	150	150	83-1/2	30	37
DVE-150L	150	150	59-1/2	36	43
DVE-200	200	180	79-1/2	36	43
DVE-250	250	240	93	36	43
DVE-300	300	300	83-1/2	42	49
DVE-350	350	330	95-1/2	42	49
DVE-400	400	390	102-1/2	42	49
DVE-500	500	480	97	48	55
DVE-600	600	600	112	48	55
DVE-700	700	690	124	48	55
DVE-800	800	780	116	54	61
DVE-1000	1000	990	116	60	67
DVE-1250	1250	1200	143	60	67
DVE-1500	1500	1500	155	60	67
DVE-2000	2000	1980	183	66	73
DVE-3000	3000	3000	217	72	79
DVE-5000	5000	3000	309	78	85
DVE-7500	7500	3000	330	90	97
DVE-10,000	10,000	3000	358	102	109

*Complete model number includes the desired kW at the end, minimum installation. Clearances required: 30” from front, 12” from top and 24” from right side.

All dimensions in inches

HORIZONTAL ELECTRIC STORAGE HEATERS					
MODEL NO.	GAL. CAP.	MAX KW INPUT	HEIGHT	WIDTH	DEPTH
DHE-200	200	180	38-1/2	77	36
DHE-250	250	240	38-1/2	91	36
DHE-300	300	300	44-1/2	81	42
DHE-350	350	330	44-1/2	93	42
DHE-400	400	390	44-1/2	100	42
DHE-500	500	480	51	94	48
DHE-600	600	600	51	109	48
DHE-700	700	690	51	121	48
DHE-800	800	780	57	111	54
DHE-1000	1000	990	61	111	60
DHE-1250	1250	1200	61	138	60
DHE-1500	1500	1500	61	150	60
DHE-2000	2000	1980	70	177	66
DHE-3000	3000	3000	76	211	72
DHE-5000	5000	3000	82	296	78
DHE-7500	7500	3000	94	317	90
DHE-10,000	10,000	3000	106	345	102

*Complete model number includes the desired kW at the end, minimum installation. Clearances required: 30” from front, 12” from top and 24” from right side.

Automatic Circulating Water Heaters



The A. O. Smith high efficiency condensing XP Water Heater utilizes a state-of-the-art heat exchanger and control technology to provide large volumes of hot water for demanding commercial and industrial potable hot water applications. The all stainless steel water tube heat exchanger construction allows the XP Water Heater to operate in a continuous condensing mode while maximizing longevity and delivering thermal efficiencies as high as 99% when operating in low temperature applications.

A unique multi-burner design is control sequenced and modulated to produce turndown rates of up to 20:1. Precise temperature control and accurate load matching produce smooth system operation and eliminates wasteful short cycling and temperature overshooting.

Advanced Multi-Burner, Low NOx Combustion Technology

- Venturi-mixing gas / air ratio system - works with variable speed blower to precisely mix gas and air throughout firing range
- Fully modulating capability prevents energy-stealing short cycling and provides smooth system operation with higher overall system efficiencies

Low NOx Operation

- Complies with SCAQMD Rule 1146.2 for XWH1000 through XWH2000 and Rule 1146.1 for XWH2600 and XWH3400, and other air quality management districts with similar requirements for low NOx emissions

Advanced Sola Control

- Large touch screen user interface
- Factory standard with MODBUS protocol connections
- The latest in energy saving algorithms
- Includes remote tank temperature control to adjust tank temperature at the water heater - modulates the water heater to maintain tank set point temperature within +/-1 degree
- Water heater output control features 20:1 turndown ratio on models 2 million btuh and up, 10:1 turndown ratio on models 1.7 million btuh and down

All-Bronze Factory-Mounted Pump(s)

- Integrally mounted, wired, and controlled by the water heater control
- Factory-sized for proper flow between water heater and storage tank
- Allows 50 equivalent feet of piping between water heater and tank

Multi-Pass/Multi-Burner Condensing Stainless Steel Heat Exchanger

- Utilizes leading-edge multi-pass water tube heat exchanger to maximize heat transfer
- Designed for fully condensing operation throughout the heating range
- All heating surfaces are 316L stainless steel to provide a long and trouble-free service life
- Saves both fuel and operating cost with every heating cycle
- Impervious to thermal shock



XWH Model Commercial Gas Water Heaters

A unique multi-burner design

Direct Vent Flexibility

- Direct vent up to 100 equivalent feet of pipe
- Sidewall or vertical
- Lower installation cost with approved CPVC / PVC venting material – uses CPVC for first 10 feet and PVC thereafter
- Approved for use with UL approved AL29-4C® stainless steel venting materials

Factory Start-Up Included

- Required for activating warranty and assuring maximum operating performance. Contact your local sales representative or Authorized Start-Up Agent to arrange a FREE certified start-up.

Meets the Thermal Efficiency Requirements of the U.S. Department of Energy and Current Edition ASHRAE/IESNA 90.1

Up to 96% Thermal Efficiency (AHRI Certified)

5-Year Heat Exchanger Warranty

- For complete information, consult written warranty or contact A. O. Smith



Other XP Features:

- CSA certified to the ANSI Z21.10.3- CSA 4.3 water heater standard
- Honeywell sola control with color touch screen LCD display
 - Inlet / outlet and remote tank temperature display
 - Onboard Modbus communications
 - Logs faults, run time, cycles
 - Redundant flow and low water protection - factory installed LWCO and flow switch(s)
 - Multi-burner sequencing models 2 million btuh and up have 4 burners; models 1.7 million btuh and down have 2 burners
 - Redundant ignition controls – should one burner fail remaining burners continue to heat
 - Alarm buzzer
- Remote tank temperature sensor included
- 20:1 turndown ratio on models 2 million btuh and up, 10:1 turndown ratio on models 1.7 million btuh and down
- Horizontal and vertical direct and sidewall vent options up to 100 equivalent feet of piping
- Approved for CPVC / PVC plastic vent materials
- Meets ASME CSD-1/GE gap codes – factory standard
- Direct spark ignition
- Factory-installed electrical disconnect
- All bronze factory-mounted pump(s)
- 316L stainless steel heat exchanger
- ASME 160# working pressure
- ASME rated pressure relief valve – 125 PSI

XP Options:

- ASME HLW stamped heat exchanger(s)
- Condensate neutralization kit
- Vent termination kits
- Skid mounted systems

RECOVERY CAPACITIES

Models	Input Rating (Btu/hr)	Water Flow	Temperature Rise - °F (°C)							
			40	60	70	80	90	100	120	140
			(22)	(33)	(39)	(44)	(50)	(56)	(67)	(78)
XWH-1000	920,000	GPH	2,662	1,775	1,521	1,331	1,183	1,065	887	761
		LPH	10,078	6,719	5,759	5,039	4,479	4,031	3,359	2,880
XWH-1300	1,300,000	GPH	3,742	2,495	2,139	1,871	1,663	1,497	1,247	1,069
		LPH	14,167	9,444	8,095	7,083	6,296	5,667	4,722	4,048
XWH-1700	1,700,000	GPH	4,904	3,269	2,802	2,452	2,180	1,962	1,635	1,401
		LPH	18,565	12,376	10,608	9,282	8,251	7,426	6,188	5,304
XWH-2000	1,999,900	GPH	5,794	3,862	3,311	2,897	2,575	2,317	1,931	1,655
		LPH	21,931	14,621	12,532	10,966	9,747	8,773	7,310	6,266
XWH-2600	2,600,000	GPH	7,501	5,000	4,286	3,750	3,334	3,000	2,500	2,143
		LPH	28,393	18,929	16,225	14,196	12,619	11,357	9,464	8,112
XWH-3400	3,400,000	GPH	9,891	6,594	5,652	4,945	4,396	3,956	3,297	2,826
		LPH	37,441	24,961	21,395	18,721	16,641	14,976	12,480	10,697

Automatic Circulating Water Heaters



SINGLE HEAT EXCHANGER MODELS

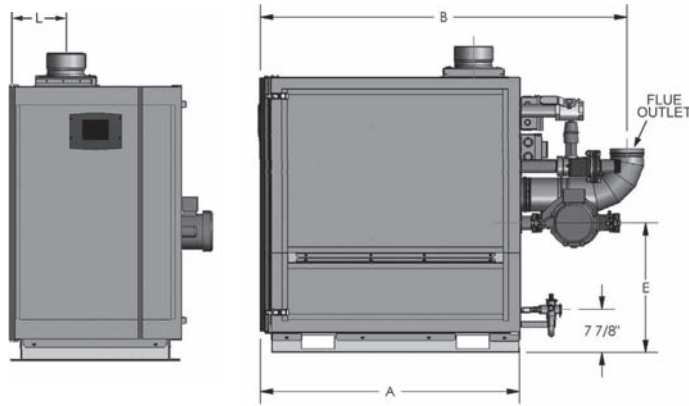

SINGLE HEAT EXCHANGER MODELS
Rough In Dimensions (Single)

Models	XWH-1000		XWH-1300		XWH-1700	
Dimensions	Inches	mm	Inches	mm	Inches	mm
Flue Outlet Diameter	6	152	8	152	8	203
Air Intake Diameter	6	152	6	152	8	203
Water Inlet	2 inch NPT		2 1/2 inch NPT			
Water Outlet	2 inch NPT		2 1/2 inch NPT			
Gas Inlet	2 inch NPT		2 inch NPT			
A	47	1199	49	1245	57	1448
B	67	1702	68	1727	76	1930
C	29	737	29	737	29	737
D	37	940	38	965	37	940
E	23	584	23	584	24	610
F	9	229	9	229	9	229
G	34	864	34	864	34	864
H	44	1118	45	1143	45	1143
J	6	152	6	152	6	152
K	11	279	11	279	11	279
L	12	305	11	279	12	305

DOUBLE HEAT EXCHANGER MODELS
Rough In Dimensions (Double)

Models	XWH-2000		XWH-2600		XWH-3400	
Dimensions	Inches	mm	Inches	mm	Inches	mm
Flue Outlet Diameter	8	203	8	203	10	254
Air Intake Diameter	8	203	8	203	10	254
Water Inlet	3 inch NPT		4 inch NPT			
Water Outlet	3 inch NPT		4 inch NPT			
Gas Inlet	2 inch NPT		3 inch NPT			
A	47	1194	49	1245	57	1448
B	78	1981	80	2032	91	2311
C	36	914	37	940	37	940
D	22	559	22	559	22	559
E	40	1016	41	1041	41	1041
F	7	178	6	152	6	152
G	10	254	10	254	10	254
H	4	102	4	102	4	102
J	20	508	19	483	19	483
K	12	305	12	305	13	330

DOUBLE HEAT EXCHANGER MODELS

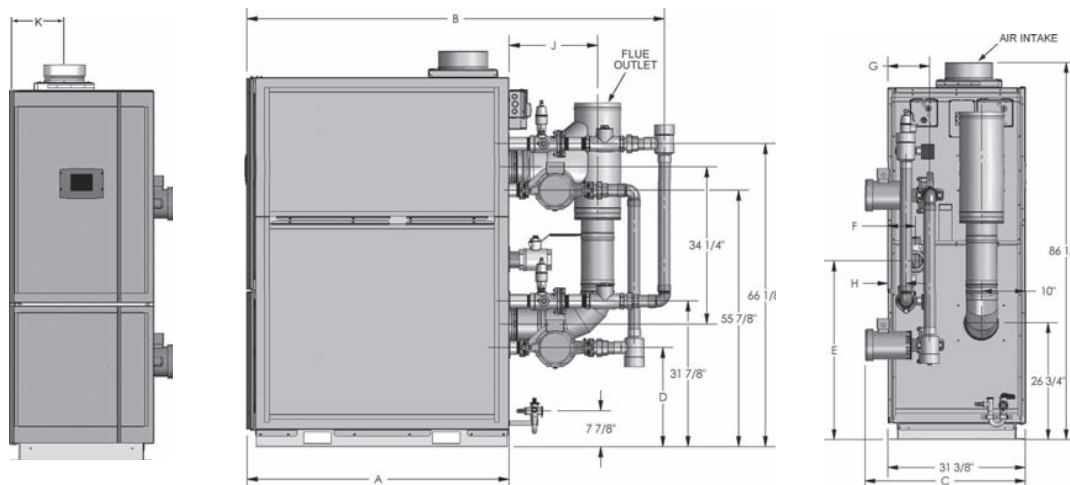

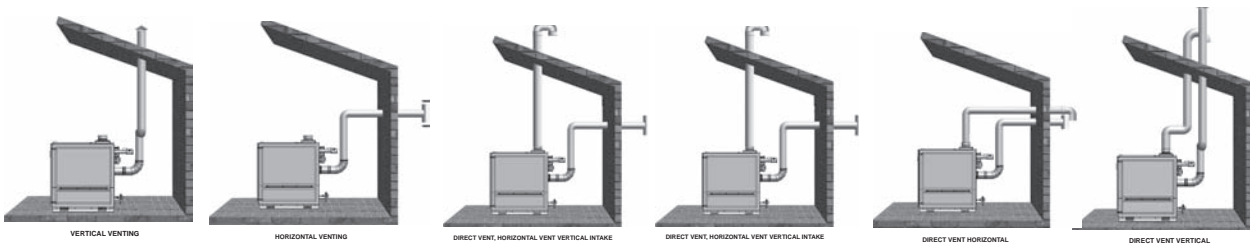

VERSATILE MULTI-VENTING CONFIGURATIONS



Direct or sidewall vent for up to 100 equivalent feet of pipe. Lower installation cost with approved CPVC/PVC venting material – uses CPVC for first 10 feet and PVC thereafter. Also approved for use with UL approved AL 29-4C stainless steel venting materials. For the detailed venting instructions review the XP water heater instruction manual at www.hotwater.com.

APPROVED VENT AND AIR INTAKE FITTINGS

EXHAUST/VENT TERMINATIONS (PVC) PART #s			
Models	Pipe Size	Vertical (PVC Rain Cap)	Horizontal (PVC Tee w/Screens)
XWH 1000	6"		
XWH 1300	8"		
XWH 1700			
XWH 2000			
XWH 2600			
XWH 3400	10"	320884-002	321765-002

AIR INTAKE TERMINATION (PVC) PART #s		
Models	Pipe Size	Combustion Air Intake (Elbow)
XWH 1000	6"	321764-000
XWH 1300		
XWH 1700		
XWH 2000	8"	321764-001
XWH 2600		
XWH 3400	10"	321764-002

Please note: When direct or sidewall venting, the water heater's CSA certification requires that only the above approved vent and combustion air intake terminations be used.

GAS PRESSURE REQUIREMENTS

MODELS (XWH)	TYPE OF GAS	MAXIMUM SUPPLY PRESSURE		MINIMUM SUPPLY PRESSURE	
		INCHES W. C.	kPa	INCHES W. C.	kPa
1000, 1300, 1700, 2000, 2500, 3400	Natural	14.0	3.49	4.0	1.0
	Propane	14.0	3.49	4.0	2.0

ELECTRICAL REQUIREMENTS

MODEL	SUPPLY VOLTAGE (VOLTS)	FREQUENCY (HZ)	CURRENT (AMPS)	ELECTRICAL NOTES:
XWH-1000	120V	60	30	A dedicated, single phase, 30/60 amp circuit breaker with a grounded neutral should be provided to supply power to the water heater.
XWH-1300	120V	60	30	
XWH-1700	120V	60	30	
XWH-2000	120V	60	60	A dedicated, single phase, 60/60 amp circuit breaker with a grounded neutral should be provided to supply power to the water heater.
XWH-2600	120V	60	60	
XWH-3400	120V	60	60	

FLOW RATE

RECOMMENDED FLOW RATES @ 0-12 GRAINS PER GALLON			
MODELS	TEMPERATURE RISE (ΔT °F)	GPM	PRESSURE LOSS IN FEET OF HEAD (P)
XWH 1000	25	70	17.5
XWH 1300	25	99	22
XWH 1700	25	129	23
XWH 2000	25	153	17.5
XWH 2600	25	198	22
XWH 3400	25	261	23

Notes: For hard water systems with water hardness greater than 12 grains per gallon, A. O. Smith recommends a water softener be installed and maintained.

The factory installed/supplied pump is sized to maintain a ΔT of 25°F through the water heater at 100% fire. In addition to the pressure loss through the water heater, the factory supplied pump is sized for an additional 50 feet of equivalent feet of piping between the water heater and a storage tank. Consult the factory for systems where the piping between the water heater and the tank exceed 50 equivalent feet.

Hydronic Heating Boilers



ASME CRN



The A. O. Smith high efficiency condensing XP Boiler utilizes a state-of-the-art heat exchanger and control technology to meet the rigorous demands of today's hydronic heating applications. The XP Boiler's all stainless steel water tube heat exchanger construction allows the XP Boiler to operate in a continuous condensing mode while maximizing longevity and delivering exceptional energy-saving performance. Low temperature applications such as heat pump and snow melting systems can see thermal efficiencies as high as 99%, a major savings over non-condensing competitive systems.

A unique multi-burner design is control sequenced and modulated to produce turndown rates of up to 20:1. Precise temperature control and accurate load matching results in smooth system operation and eliminates wasteful short cycling and temperature overshooting.

Advanced Multi-Burner, Low NOx Combustion Technology

- Venturi-mixing gas/air ratio system - works with variable speed blower to precisely mix gas and air throughout firing range
- Fully modulating capability prevents energy-stealing short cycling and provides smooth system operation with higher overall system efficiencies

Low NOx Operation

- Complies with SCAQMD Rule 1146.2 for XB1000 through XB2000 and Rule 1146.1 for XB2600 and XB3400, and other air quality management districts with similar requirements for low NOx emissions

Advanced Sola Control

- Large touch screen user interface
- Direct MODBUS protocol connections
- The latest in energy saving algorithms
- Outdoor reset is standard and includes remote outdoor temperature sensor - modulates the boiler to maintain desired system temperature within +/-1 degree
- Boiler output control features 20:1 turndown ratio on models 2 million btuh and up, 10:1 turndown ratio on models 1.7 million btuh and down

Factory-Mounted Secondary Pump(s) (optional)

- Recommended for primary/secondary piping systems
- Integrally mounted, wired, and controlled by the boiler control
- Factory-sized for proper flow through the boiler
- Allow up to 50 equivalent feet of piping between the boiler and the primary heating system

Multi-Pass/Multi-Burner Condensing Stainless Steel Heat Exchanger

- Utilizes leading-edge multi-pass water tube heat exchanger to maximize heat transfer
- Designed for fully condensing operation throughout the heating range
- All heating surfaces are 316L stainless steel to provide a long and trouble-free service life
- Saves fuel and operating cost with every heating cycle
- Impervious to thermal shock

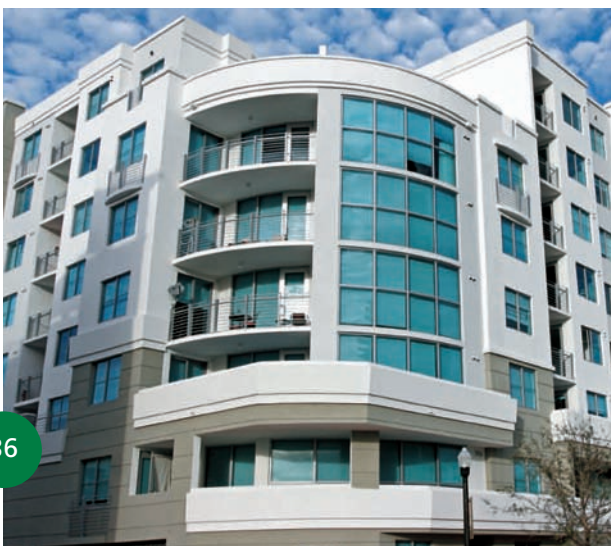

Precise temperature control and accurate load matching results in smooth system operation

XB Model Boilers

Direct Vent Flexibility

- Direct vent up to 100 equivalent feet of pipe
- Sidewall or vertical
- Lower installation cost with approved CPVC/PVC venting material – uses CPVC for first 10 feet and PVC thereafter.
- Approved for use with UL approved AL29-4C® stainless steel venting materials

Factory Start-Up Included

- Required for activating warranty and assuring maximum operating performance. Contact your local sales representative or Authorized Start-Up Agent to arrange a FREE certified start-up.

Category IV Listed

- Approved for use with CPVC/PVC venting material – uses CPVC for first 10 feet then PVC thereafter or a UL approved AL 29-4C Stainless Steel venting material

Professional Start-Up Service Included

- Assures optimum performance for each installation

Meets the Thermal Efficiency Requirements of the U.S. Department of Energy and Current Edition ASHRAE/IESNA 90.1

10-Year Heat Exchanger Warranty

- For complete information, consult written warranty or contact A. O. Smith

Other XP Boiler Features:

- 93% thermal efficiency (AHRI certified)
- Certified to ANSI Z21.13-CSA 4.9
- Honeywell sola control with color touch screen LCD display
 - Inlet/outlet and remote loop temperature display
 - Onboard modbus communications
 - Logs faults, run time, cycles
 - Redundant flow and low water protection - factory-installed LWCO and flow switch(s)
 - Multi-burner sequencing models 2 million btuh and up have 4 burners; models 1.7 million btuh and down have 2 burners
 - Redundant ignition controls – should one burner fail remaining burners continue to heat
 - Alarm buzzer
 - Outdoor temperature sensor included
- 20:1 turndown models 2 million btuh and up, 10:1 turndown models 1.7 million btuh and down
- Horizontal and vertical direct and sidewall vent options up to 100 equivalent feet of piping
- Approved for CPVC/PVC plastic vent materials
- Meets ASME CSD-1/GE gap codes – factory standard
- Direct spark ignition
- Factory-installed electrical disconnect
- 316L Stainless steel heat exchanger
- ASME 160# working pressure
- ASME rated pressure relief valve – 50 PSI

XP Boiler Options:

- Factory-mounted secondary pump (recommended for primary/secondary piping systems)
- Condensate neutralization kit
- Vent termination kits
- Skid mounted systems



XB MODELS - FLOW, HEAD AND TEMPERATURE RISE								
Models	Input (Btu/hr)	Output (Btu/hr)	Water Flow	Temperature Rise - ΔT °F			Flow Rate	
				20	30	40	Maximum	Minimum
XB-1000	920,000	855,600	GPM	86	57	43	86	43
			LPM	324	216	162	324	162
			ΔP FT	26	12	7	26	7
			ΔP M	7.9	3.7	2.1	8	2.1
			GPM	121	81	60	121	60
XB-1300	1,300,000	1,209,000	LPM	458	305	229	458	229
			ΔP FT	32.5	15	8	32.5	8
			ΔP M	9.9	4.6	2.4	9.9	2.4
			GPM	158	105	79	158	79
			LPM	598	399	299	598	299
XB-1700	1,700,000	1,581,000	ΔP FT	35	14	8	35	8
			ΔP M	10.7	4.3	2.4	10.7	2.4
			GPM	186	124	93	186	93
			LPM	704	469	352	704	352
			ΔP FT	26	12	7	26	7
XB-2000	1,999,900	1,859,907	ΔP M	7.9	3.7	2.1	7.9	2.1
			GPM	242	161	121	242	121
			LPM	915	610	458	915	458
			ΔP FT	32.5	15	8	33	8
			ΔP M	9.9	4.6	2.4	9.9	2.4
XB-2600	2,600,000	2,418,000	GPM	316	211	158	316	158
			LPM	1197	798	598	1197	598
			ΔP FT	35	14	8	35	8
			ΔP M	10.7	4.3	2.4	11	2.4
			GPM	1197	798	598	1197	598
XB-3400	3,400,000	3,162,000	ΔP FT	35	14	8	35	8
			ΔP M	10.7	4.3	2.4	11	2.4
			GPM	1197	798	598	1197	598
			LPM	1197	798	598	1197	598
			ΔP FT	35	14	8	35	8

Hydronic Heating Boilers



SINGLE HEAT EXCHANGER MODELS

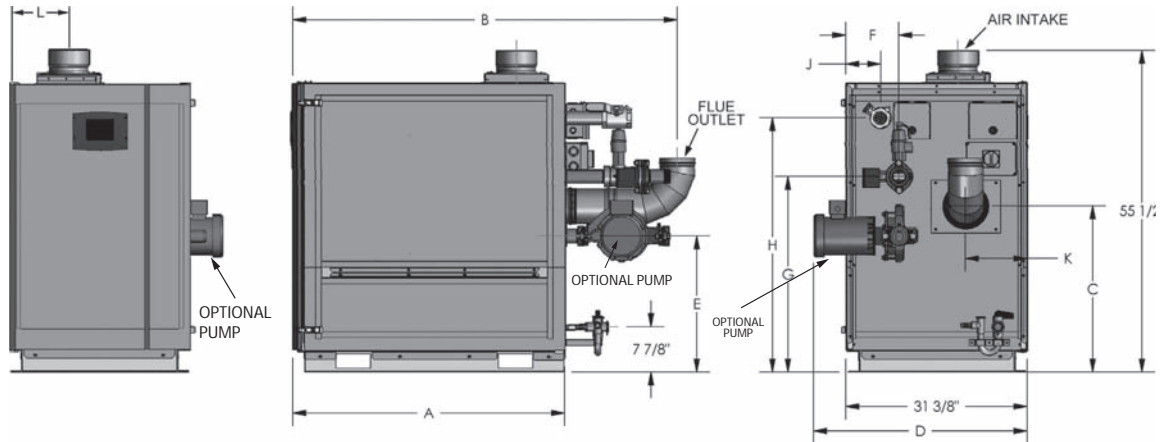

SINGLE HEAT EXCHANGER MODELS
Rough In Dimensions (Single)

Models	XB-1000		XB-1300		XB-1700	
Dimensions	Inches	mm	Inches	mm	Inches	mm
Flue Outlet Diameter	6	152	8	152	8	203
Air Intake Diameter	6	152	6	152	8	203
Water Inlet	2 inch NPT				2 1/2 inch NPT	
Water Outlet	2 inch NPT				2 1/2 inch NPT	
Gas Inlet	2 inch NPT				2 inch NPT	
A	47	1199	49	1245	57	1448
B	67	1702	68	1727	76	1930
C	29	737	29	737	29	737
D	37	940	38	965	37	940
E	23	584	23	584	24	610
F	9	229	9	229	9	229
G	34	864	34	864	34	864
H	44	1118	45	1143	45	1143
J	6	152	6	152	6	152
K	11	279	11	279	11	279
L	12	305	11	279	12	305

DOUBLE HEAT EXCHANGER MODELS
Rough In Dimensions (Double)

Models	XB-2000		XB-2600		XB-3400	
Dimensions	Inches	mm	Inches	mm	Inches	mm
Flue Outlet Diameter	8	203	8	203	10	254
Air Intake Diameter	8	203	8	203	10	254
Water Inlet	3 inch NPT				4 inch NPT	
Water Outlet	3 inch NPT				4 inch NPT	
Gas Inlet	2 inch NPT				3 inch NPT	
A	47	1194	49	1245	57	1448
B	78	1981	80	2032	91	2311
C	36	914	37	940	37	940
D	22	559	22	559	22	559
E	40	1016	41	1041	41	1041
F	7	178	6	152	6	152
G	10	254	10	254	10	254
H	4	102	4	102	4	102
J	20	508	19	483	19	483
K	12	305	12	305	13	330

DOUBLE HEAT EXCHANGER MODELS

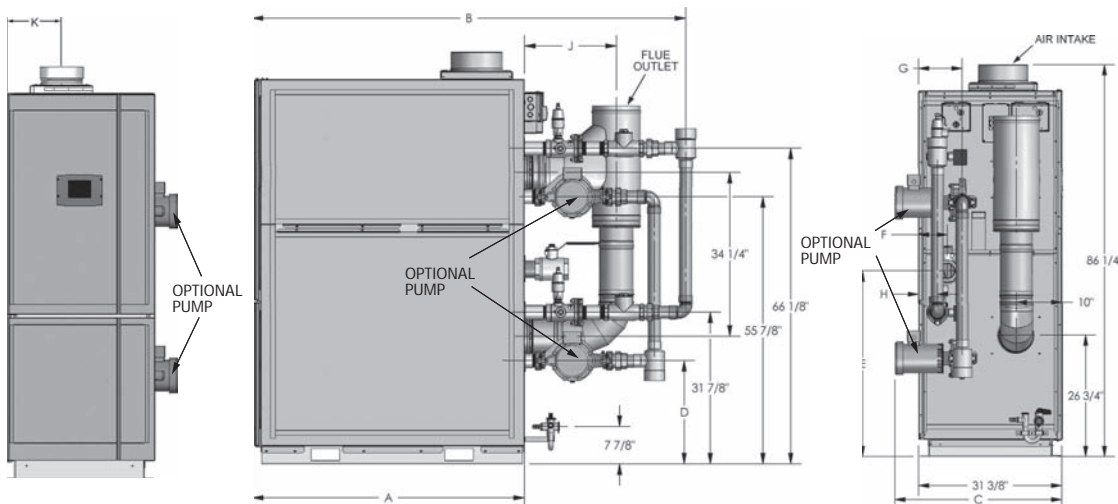

Thermal efficiencies as low as 99%

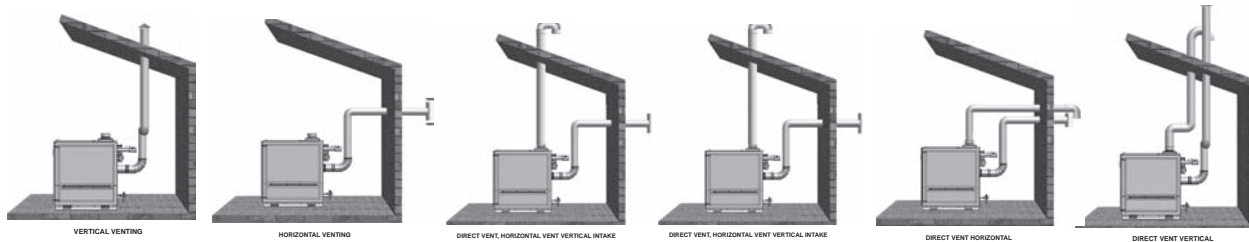

XB Model Boilers

VERSATILE MULTI-VENTING CONFIGURATIONS



Direct or sidewall vent for up to 100 equivalent feet of pipe. Lower installation cost with approved CPVC/PVC venting material – uses CPVC for first 10 feet and PVC thereafter. Also approved for use with UL approved AL 29-4C stainless steel venting materials. For the detailed venting instructions review the XP boiler instruction manual at www.hotwater.com.

APPROVED VENT AND AIR INTAKE FITTINGS

EXHAUST/VENT TERMINATIONS (PVC)			
Models	Pipe Size	Vertical (PVC Rain Cap)	Horizontal (PVC Tee w/Screens)
XB 1000	6"		
XB 1300	8"		
XB 1700			
XB 2000			
XB 2600			
XB 3400	10"	320884-002	321765-002

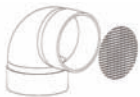
AIR INTAKE TERMINATION (PVC)		
Models	Pipe Size	Combustion Air Intake (Elbow)
XB 1000	6"	
XB 1300		
XB 1700		
XB 2000	8"	321764-001
XB 2600		
XB 3400	10"	321764-002

Please note: When direct or sidewall venting, the boiler's CSA certification requires that only the above approved vent and combustion air intake terminations be used.

GAS PRESSURE REQUIREMENTS

MODELS (XWH)	TYPE OF GAS	MAXIMUM SUPPLY PRESSURE		MINIMUM SUPPLY PRESSURE	
		INCHES W. C.	kPa	INCHES W. C.	kPa
1000, 1300, 1700, 2000, 2500, 3400	Natural	14.0	3.49	4.0	1.0
	Propane	14.0	3.49	4.0	2.0

ELECTRICAL REQUIREMENTS

MODEL	SUPPLY VOLTAGE (VOLTS)	FREQUENCY (HZ)	CURRENT (AMPS)	ELECTRICAL NOTES:
XB-1000	120V	60	30	A dedicated, single phase, 30/60 amp circuit breaker with a grounded neutral should be provided to supply power to the boiler.
XB-1300	120V	60	30	
XB-1700	120V	60	30	
XB-2000	120V	60	60	A dedicated, single phase, 60/60 amp circuit breaker with a grounded neutral should be provided to supply power to the boiler.
XB-2600	120V	60	60	
XB-3400	120V	60	60	

Dura-Max® DB/DW Gas Models

Up To 82% thermal efficiency hot water supply and hydronic heating boilers



The Dura-Max® series offers excellent performance and low-profile design flexibility for both new construction and retrofit applications. A double-row, extruded-finned copper tube heat exchanger provides exceptional heat transfer efficiency. Each unit features a small footprint with a built-in draft diverter for extra clearance to simplify installation. Reliable, quiet, drawer-mounted stainless steel burners resist corrosion, improve access for easy maintenance.

100% All Non-Ferrous Waterways

- All waterways 100% copper, brass or bronze... won't rust, resists thermal shock
- Heavy-duty bronze castings and copper heat exchange tubes
- Bronze removable return bends for easy access and inspection of individual tubes

Drawer Mounted, Stainless Steel Burners

- Quiet operation and efficient, reliable design
- Protects against corrosion and condensation deterioration common to aluminum burners
- Easy slide-out burner tray simplifies cleaning and maintenance

Compact, Low Profile Design

- Built-in draft diverter provides extra clearance in tight, retrofit installations
- Clean, compact jacket design for easy access and assembly
- Cool to touch and approved for combustible floors

Gasketless Wet Section

- Unique "O" ring design compresses to form water-tight seal positioned away from and outside the combustion chamber
- Isolated location offers optimum protection and years of service without gasket leaks

Intermittent Electronic Ignition

- Eliminates standing pilot, saves energy
- Includes power ON/OFF switch
- Provides flame failure response in less than one second

Meets the thermal efficiency and standby loss requirements of the U.S. Department of Energy and current edition of ASHRAE/IESNA90.1

5-Year Heat Exchanger Limited Warranty
(Domestic hot water supply)

10-Year Heat Exchanger Limited Warranty
(Hydronic heating applications)



Up To 82% thermal efficiency hot water supply and hydronic heating boilers

Burkay® HW Gas Models

Famous Burkay® reliability. Because of their lightweight and compact design, they may be easily transported on a two-wheel dolly replacing large boilers in a much smaller space. Burkay® models are for indoor use in installations requiring higher inputs...up to 670,000 BTU. They can be manifolded for unlimited fire power.

100% All Non-Ferrous Waterways

- All waterways 100% copper, brass or bronze... resists thermal shock and corrosion buildup

Low Profile Diverter

- Special design allows maximum installation flexibility

Copper Wall Combustion Chamber

- Coils of tightly wound copper tubing form a unique and highly efficient combustion chamber
- Optimum energy transfer achieved with integral extruded fin copper-finned tubes

Meets the thermal efficiency and standby loss requirements of the U.S. Department of Energy and current edition of ASHRAE/IESNA90.1

5-Year Heat Exchanger Limited Warranty (Domestic hot water supply)

10-Year Heat Exchanger Limited Warranty (Hydronic heating applications)



All dimensions in inches

HW BURKAY MODELS										
MODEL NO.	INPUT BTU/HOUR	OUTPUT BTU/HOUR	TEMP RISE °F-GPH			VENT DIA.	HT.	DIA.	DPT	SHIP WEIGHT
			40	100	140					
HW-120M	120,000	99,840	300	120	86	6	49-3/8	20-3/4	26-11/16	120
HW-160M	160,000	128,320	385	154	110	7	50-1/8	20-3/4	26-11/16	154
HW-200M	199,000	162,185	487	195	139	7	53-1/4	20-3/4	26-11/16	165
HW-225M	225,000*	180,900	543	217	155	7	60	20-3/4	26-11/16	175
HW-300	300,000	247,200	742	297	212	8	65	25-1/4	29-5/8	240
HW-399	399,000	322,790	969	388	277	10	57-1/8	27	31-1/2	291
HW-420	420,000	344,400	1034	413	295	10	57-1/8	27	31-1/2	291
HW-520	520,000	429,000	1288	515	368	10	68-5/16	27	36-1/2	361
HW-670	660,000	543,800	1632	656	466	12	67	27	38-1/4	361

*Available in natural gas only

All dimensions in inches

DURA-MAX DB AND DW MODELS										
MODEL NO.+	INPUT BTU/HOUR*	OUTPUT BTU/HOUR	TEMP RISE °F-GPH			VENT DIA.	HT.	DIA.	DPT	SHIP WEIGHT
			40	100	140					
DB/DW-720	720,000	583,200	1767	707	505	12	54-3/4	46-1/2	29-5/8	780
DB/DW-840	840,000	680,400	2062	825	589	14	54-3/4	52-1/5	29-5/8	950
DB/DW-960	960,000	777,600	2356	943	673	14	54-3/4	57-3/4	29-5/8	950
DB/DW-1080	1,080,000	885,600	2684	1073	767	16	58	52-7/8	32-3/4	1000
DB/DW-1210	1,210,000	992,200	3007	1203	859	16	58	58-1/2	32-3/4	1075
DB/DW-1350	1,350,000	1,107,000	3355	1342	958	18	58	64-1/2	32-3/4	1100
DB/DW-1480	1,480,000	1,184,000	3588	1435	1025	18	60-1/2	69-1/2	34	1125
DB/DW-1610	1,610,000	1,288,000	3903	1561	1115	18	60-1/2	75	34	1150
DB/DW-1810	1,810,000	1,448,000	4388	1755	1254	20	60-1/2	82-1/2	34	1250

*Available in natural gas only

Production of +DB/DW Models will be discontinued in March 2012

Burkay® Genesis® GB/GW-300 thru 2500 Gas Water Boilers

84% thermal efficiency, extreme venting flexibility, outstanding value



Shown with optional factory mounted and wired secondary pump.



A. O. Smith Genesis boilers offer everything you could ask for in a non-condensing boiler. They provide the highest possible 84% thermal efficiency, outstanding venting flexibility, space-saving stackable design and a new, advanced Energy Management Control (EMC) system. Genesis models are available for installation indoors (GB/GW Series) or outdoors (GBO/GWO Series).



EMC-5000 Energy Management Control

- Patent pending
- Controls every electrical boiler function, including pump operation and main burner ignition, delivers precise temperature management with $\pm 1^\circ\text{F}$ accuracy
- Display panel shows current operating status and fault readings in easy-to-understand English instead of confusing numeric codes
- Display also shows temperature set points, outlet temperature, current inlet/outlet differential (ΔT) and tank temperature
- Help screens assist in boiler setup and explain all control options
- Includes 120V terminals for installation of secondary pump up to 1/3 HP allows control to cycle secondary pump for maximum efficiency, virtually eliminates standby heat loss at the boiler



Advanced Electronic Controls

- iCOMM™ Compatible and can be monitored from remote locations. Call 1.888.WATER02 for more information.

Network Ready for Future Remote Capabilities

Multi-Stage Firing System

- Multiple gas valve firing system ensures smooth operation, saves fuel and extends boiler life (Models GW/GB-300 through 750 are 2-stage firing; Models GW/GB-1000 through 1500 are 3-stage firing; Models GW/GB-1850 through 2500 are 4-stage firing)
- Prevents short cycling during low demand periods, delivers maximum output when demand is high

Available In Two Models

- Domestic hot water supply – GW models
- Hydronic heating – GB models

Low NOx Operation

- Complies with SCAQMD Rule 1146.2 and other Air Quality Management Districts with similar requirements for low NOx emissions+

Meets the thermal efficiency and standby loss requirements of the U.S. Department of Energy and current edition of ASHRAE/IESNA90.1

10-Year Heat Exchanger Limited Warranty
(Hydronic heating applications)

5-Year Heat Exchanger Limited Warranty
(Domestic hot water supply)



Burkay® Genesis® GB/GW-1000 thru 2500 Gas Water Boilers



Complies with
SCAQMD
Rule 1146.2
California and Texas
California and Texas

ASME
CRN



Combustion Air Blower with Air Shutter
Adjusts to the application for maximum efficiency.

Top or Rear Exhaust

Extruded Finned-Copper Tube

- Finned-copper design delivers superior heat transfer and energy efficiency
- Self-baffling tube design assures even flow through heat exchanger
- Copper is lightweight, immune to rust and thermal shock
- Double-row configuration on 1,000,000 BTU input and higher...fits maximum heat transfer into minimum space



Removable Bronze or Glasslined Cast-Iron Headers
For easy inspection and service of waterways.

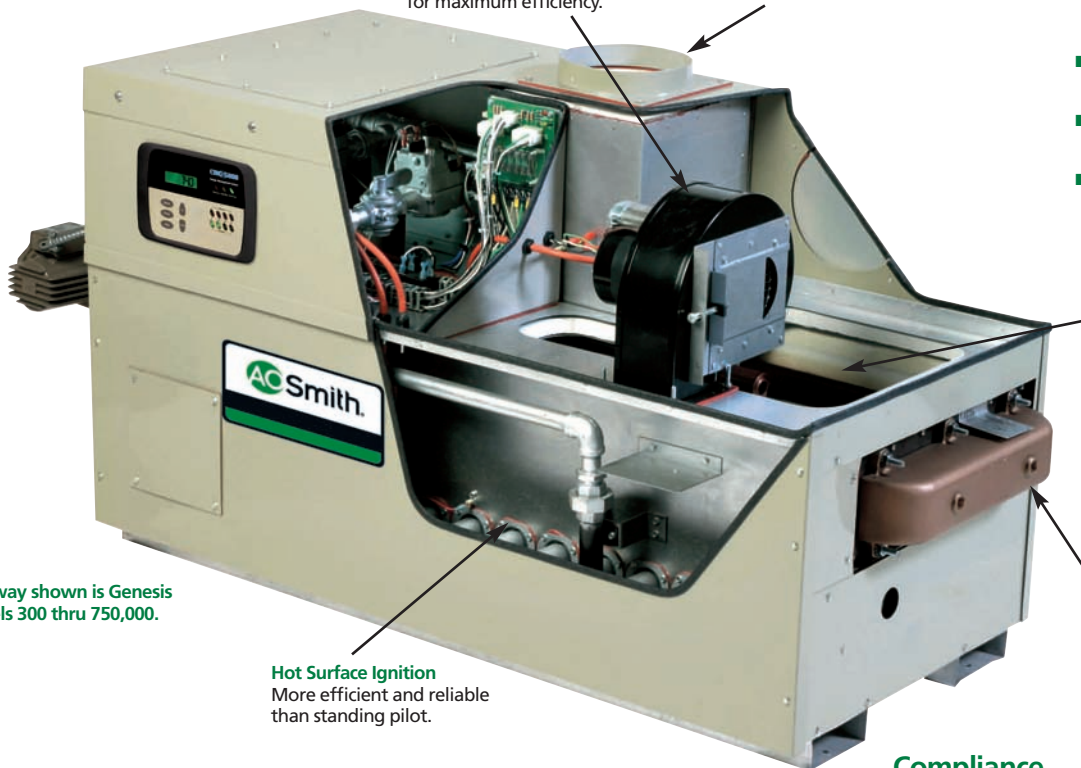

Cutaway shown is Genesis models 300 thru 750,000.

Hot Surface Ignition
More efficient and reliable than standing pilot.

Two to four-Stage Firing with Separate Remote Flame Sensors
For safety and extended ignitor life. Individual sensors for each stage.

Pressurized Combustion System
With pre-jet orifice for near-perfect air/gas mixture, clean combustion, low NOx.

Compliance

- Meets the thermal efficiency and standby loss requirements of the U.S. Department of Energy and current edition of ASHRAE/IESNA90.1+

All dimensions in inches

MODELS GB/GW-300—750 HOT WATER SUPPLY AND HYDRONIC BOILERS												
MODEL NO.+	INPUT BTU/HOUR NAT & PROPANE	TEMPERATURE RISE °F-GPH HOT WATER SUPPLY ONLY			WATER CONN.	GAS CONN.	VENT/ INTAKE CONN.	HEIGHT	WIDTH	WIDTH WITH PUMP	DEPTH	APPROX SHIP WEIGHT
		40	100	140								
INDOOR GB/GW SERIES												
GB/GW-300	300,000	761	304	217	1-1/2	3/4	5	30	29-1/2	41-1/2	24	414
GB/GW-400	399,900	1014	406	290	1-1/2	1	6	30	35-3/4	50-1/2	24	476
GB/GW-500	500,000	1268	507	362	2	1	6	30	42	56-3/4	24	526
GB/GW-650	650,000	1649	659	471	2	1-1/4	8	30	51-3/8	66-1/8	24	612
GB/GW-750	750,000	1902	761	544	2	1-1/4	8	30	57-3/8	74-5/8	24	702
OUTDOOR GBO/GWO SERIES												
GBO/GWO-300	300,000	761	304	217	1-1/2	3/4	5	41-7/8	49	-	-	414
GBO/GWO-400	399,900	1014	406	290	1-1/2	1	6	41-7/8	55-1/4	-	-	476
GBO/GWO-500	500,000	1268	507	362	2	1	6	41-7/8	61-1/2	-	-	526
GBO/GWO-650	650,000	1649	659	471	2	1-1/4	8	41-7/8	70-7/8	-	27-11/16	612
GBO/GWO-750	750,000	1902	761	544	2	1-1/4	8	41-7/8	77-1/8	-	27-11/16	702

All dimensions in inches

MODELS GB/GW1000-2500 HOT WATER SUPPLY AND HYDRONIC BOILERS												
MODEL NO.+	INPUT BTU/HOUR NAT & PROPANE	TEMPERATURE RISE °F-GPH HOT WATER SUPPLY ONLY			WATER CONN.	GAS CONN.	VENT/ INTAKE CONN.	HEIGHT	WIDTH	WIDTH WITH PUMP	DEPTH	APPROX SHIP WEIGHT
		40	100	140								
INDOOR GB/GW SERIES												
GB/GW-1000	990,000	2520	1008	720	2-1/2	2	10/8	40-1/2	47	64	31-3/4	936
GB/GW-1300	1,300,000	3309	1324	945	2-1/2	2	12/10	40-1/2	57-1/2	74-1/2	31-3/4	1050
GB/GW-1500	1,500,000	3818	1527	1091	2-1/2	2	12/10	40-1/2	64-1/2	81-1/2	31-3/4	1274
GB/GW-1850	1,850,000	4709	1884	1345	2-1/2	2-1/2	14/12	43-1/4	78-3/4	95-3/4	31-3/4	1404
GB/GW-2100	2,100,000	5345	2138	1527	2-1/2	2-1/2	14/12	43-1/4	85-1/2	102-1/2	31-3/4	1508
GB/GW-2500	2,490,000	6338	2535	1811	2-1/2	2-1/2	16/14	43-1/4	99-1/2	116-1/2	31-3/4	1581
OUTDOOR GBO/GWO SERIES												
GBO/GWO-1000	990,000	2520	1008	720	2-1/2	2	10/8	58-11/16	66	-	31-5/8	936
GBO/GWO-1300	1,300,000	3309	1324	945	2-1/2	2	12/10	58-11/16	76-1/2	-	31-5/8	1050
GBO/GWO-1500	1,500,000	3818	1527	1091	2-1/2	2	12/10	58-11/16	83-1/2	-	31-5/8	1274
GBO/GWO-1850	1,850,000	4709	1884	1345	2-1/2	2-1/2	14/12	61-3/8	97-1/2	-	31-5/8	1404
GBO/GWO-2100	2,100,000	5345	2138	1527	2-1/2	2-1/2	14/12	61-3/8	104-1/2	-	31-5/8	1508
GBO/GWO-2500	2,490,000	6338	2535	1811	2-1/2	2-1/2	16/14	61-3/8	118-1/2	-	31-5/8	1581

+After January 1, 2012, Models will not meet SCAQMD Rule 1146.2 requirements for low NOx emissions.

Venting Flexibility

Direct Venting Examples

- Allows clean, uncontaminated air to be drawn directly into the unit
- Flue gas by-products are expelled through the wall to the outside
- Sidewall or vertical
- The boiler can be vented directly through an outside wall or vertically through the roof

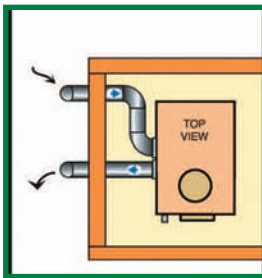

Horizontal sidewall direct-venting rear intake/exhaust

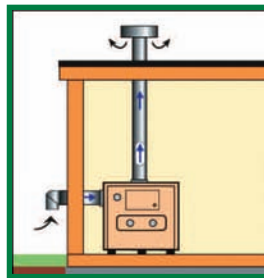

Vertical direct-venting with horizontal combustion air intake rear intake/top exhaust

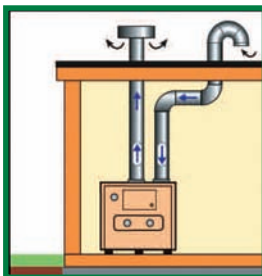

Vertical direct-venting top intake/exhaust

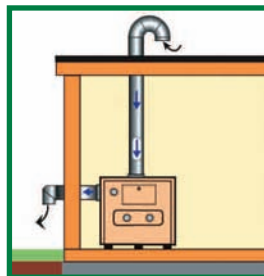

Horizontal direct-venting with vertical combustion air intake top intake/rear exhaust

Conventional Venting Examples

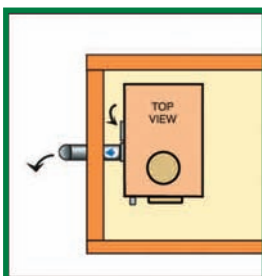

Horizontal sidewall-venting with rear exhaust

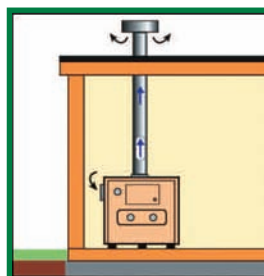

Conventional vertical-venting with top exhaust

See *Installation Manual* for complete venting installation instructions and maximum intake combustion air and exhaust venting distances.

Extruded Finned-Copper Tube

- Designed for maximum durability and serviceability
- Copper is lightweight for easier handling and immune to thermal shock



Other Genesis Features

- Alternate thermostat terminals (24V)
- CSA Certified and ASME rated T&P relief valve
- Factory-installed flow switch
- Manual reset high limit
- Blocked flue switch
- Fan proving switch
- Adjustable secondary pump delay
- Removable headers allow easy inspection of waterways

Genesis Options

- Factory-mounted and wired boiler pump for primary or secondary piping systems
- CSD-1 code
- New York and California code
- Alarm bell
- Dry contacts for any boiler failure
- E.M.S. stage control adapter
- Stack rack
- Low water cut off
- Sequencing control panel with outdoor reset for 1–8 boilers
- Combustible floor shield
- Cupro-nickel heat exchanger
- Extended venting kit
- CSA certified vent kits

Variable Fire Boilers

Up to 88% efficient, hot water supply boiler with modulating fire 4:1 turndown



The Art of Flexibility

The new VF Series variable fire copper tube boilers are designed with one thing in mind: to provide the best value to the customer. As a result, we're proud to introduce a more installation-friendly line that works well in more applications and requires less maintenance.

The secret to the stunning performance of the VF Series is its flexibility. The VF is capable of firing from 100% to 25% or a 4:1 turndown ratio. The boiler's output is based strictly on the current system demand and required BTUs needed to maintain the desired system set point temperature. The VF's modulating capability is virtually limitless.

The VF Boiler sets a high efficiency standard by combining thermal efficiencies up to 88% with a smoother, more energy-efficient overall system operation.

Small Size and Easy Service

Small Footprints, Zero Clearance To Combustibles On Sides of Unit

- Compact design, lightweight copper heat exchanger makes VF Series easier to move and install in limited spaces—perfect for retrofits
- Fits in an elevator, ideal for boiler rooms with limited access—only 30" wide
- Multiple boiler systems provide increased turndown and even smoother, more efficient system operation
- 4 boilers w/4:1 turndown = 16:1 total system turndown

Advanced Electronic Controls

- iCOMM™ Compatible and can be monitored from remote locations. Call 1.888.WATER02 for more information

Category IV Listed

Meets the thermal efficiency and standby loss requirements of the U.S. Department of Energy and current edition of ASHRAE/IESNA 90.1

Low NOx Operation

- Complies with SCAQMD Rule 1146.2 and other Air Quality Management Districts with similar requirements for Low NOx emissions

Other VF™ Boiler Features:

- ASME rated Pressure Relief Valve
- Factory-Mounted Flow Switch
- Low Gas Pressure Switch
- All Bronze Factory-Mounted Pump (Standard on VV hot water supply models)
- Digital Inlet/Outlet Temperature Read Out
- Manual Reset Hi Limit
- Network ready for future remote capabilities

5-Year Heat Exchanger Limited Warranty (Domestic hot water supply)

10-Year Heat Exchanger Limited Warranty (Hydronic heating applications)

CSD-1 Controls

VF™ Boiler Approved Options*

*For optional boiler equipment, see VF Boiler VB and VV spec sheets.

All dimensions in inches

VW AND VB MODELS											
MODEL NO.	INPUT BTU/HOUR	OUTPUT BTU/HOUR	GALLONS PER HOUR TEMP RISE-°F			VENT CONN.	HT.	WIDTH	DEPTH W/ PUMP	DEPTH W/O PUMP	SHIP WEIGHT
			40	100	140						
VW/VB-500	500,000	421,500	1268	507	362	6	56	30	37-1/2	30	450
VW/VB-750	750,000	633,750	1901	761	543	6	62	30	37-1/2	30	575
VW/VB-1000	1,000,000	845,000	2535	1014	724	6	71	30	37-1/2	30	750
VW/VB-1500	1,500,000	1,260,000	3780	1521	1080	7	67	30-1/2	60-1/4	37	925
VW/VB-2000	2,000,000	1,680,000	5040	2016	1440	7	72	30-1/2	60-1/4	37	1025

A

Combustion air intake—self adjusting, no air shutter required

B

EMC-5000 Modulating Control

C

Advanced pre-mix burner design precisely mixes air and gas prior to ignition for optimum performance. Complies with SCAQMD Rule 1146.2 and other Air Quality Management Districts with similar requirements for Low NOx emissions.

D

All non-heating components are outside of the combustion and flue collection areas; only the copper fin tubes are exposed to the products of combustion



E

Venturi-mixing gas/air ratio system works with variable speed blower to precisely mix gas and air throughout firing range, provides good operation with supply gas pressures down to 4" WC for natural gas (8" WC for propane) and is self-adjusting for altitudes up to 6,000 feet, all while providing low-NOx emissions that meet or exceed the most stringent standards

F

Heavy-duty ASME 160 PSI extruded finned copper tube heat exchanger—vertical, straight tube, two-pass design surrounds the burner with a 360° wall of copper finned tubing, making the entire heat exchanger resistant to thermal shock

G

The sealed heat exchanger flue collection system is constructed of AL29-4C stainless steel that resists corrosive flue gases

Versatile Multi-Venting Configurations

- Direct venting vertical and/or horizontal sidewall, with all combustion makeup air drawn from outside the building

70 Equivalent Feet Exhaust
 70 Equivalent Feet Intake
 90 Degree Elbows = 10 Feet
 45 Degree Elbows = 5 Feet
 Boot Tee = 5 Feet

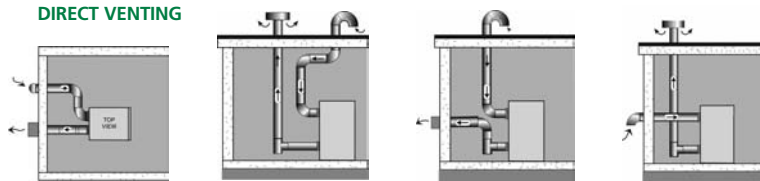

- Conventional venting, vertical or horizontal sidewall

100 Equivalent Feet Max
 90 Degree Elbows = 10 Feet
 45 Degree Elbows = 5 Feet
 Boot Tee = 5 Feet

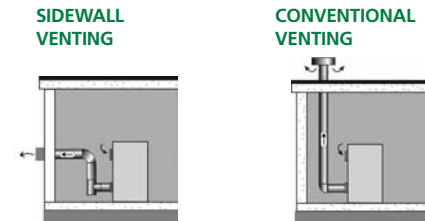

See Instruction Manual for complete venting installation instructions and maximum intake combustion air and exhaust venting distances.

Advanced EMC-5000 Modulating Control

The EMC-5000 Modulating Control provides true self-diagnostic capabilities to eliminate guesswork in troubleshooting. It is the most advanced boiler control we have ever offered, setting a new standard for copper boilers.

EMC-5000 Modulating Control

- Modulates the boiler to maintain tank temperature within $\pm 1^\circ$
- Infinite boiler output control between 100% to 25% fire
- LED read out – provides current boiler status in plain English with help screens to assist should a fault occur
- Controls and monitors every electrical boiler function with onboard diagnostics



Advanced Electronic Controls

- iCOMM™ Compatible and can be monitored from remote locations. Call 1.888.WATER02 for more information



Variable Fire (VF™) Boilers



Ac-U-Temp —A total hot water supply system using VF Series Boilers

With Ac-U-Temp, A. O. Smith makes it as easy as possible to install a complete packaged hot water supply system, combining 88% efficient VF Series Boilers with A. O. Smith storage tanks. A. O. Smith offers a wide range of available boiler/storage tank combinations using the Ac-U-Temp system. There are a number of standard boiler and tank configurations with tanks up to 1,000 gallons, or we can custom design and build an Ac-U-Temp system with tanks up to 10,000 gallons to meet your specifications and application requirements. Ac-U-Temp systems are shipped fully assembled, pre-piped and pre-wired. All the installer has to do is make the flue, gas, electrical and water connections, so field errors are minimized.

Consult your A. O. Smith representative for more information on the wide range of available boiler/storage tank combinations using the Ac-U-Temp system.

For complete specifications on the VF Series, consult the specification sheets at www.hotwater.com or contact your local A. O. Smith sales representative.

Ac-U-Temp Complete Hot Water Supply Systems

Built to order...factory-engineered and pre-assembled...easier to install



We've taken our best commercial boilers and tanks and made them available in a total system called Ac-U-Temp. Completely pre-piped and pre-wired, built to your specifications and skid-mounted, Ac-U-Temp systems streamline installation and reduce labor costs. Once on-site, the installer simply connects the flue, gas, electric supply, cold water make-up and hot water supply.

Tank Capacities

- Standard tank sizes from 80 to 1,000 gallons
- Custom tanks to 10,000 gallons

Eliminates Costly Field Errors

- Factory-engineered and assembled to assure proper pipe, pump and wired sizing
- Systems are pre-piped and wired to guarantee maximum system efficiency

Simplifies Installation

- Installer simply connects the flue, gas, electric supply, cold water make-up and hot water supply

Ac-U-Temp Storage Tanks

- Each tank is specially designed with tank opening locations that provide maximum tank draw efficiency and eliminate any unnecessary piping and connections
- Standard Ac-U-Tanks are factory jacketed and insulated (Bare tanks are also available)

Custom Ac-U-Temp Systems

- All systems are built to order to meet your specifications
- Many type of boiler and tank combinations are available

Multi-Boiler Systems

- High recovery systems that can meet any hot water demand
- Systems can be designed to provide 50%–100% back-up
- Boilers can be On & Off-fired or sequenced to meet changing system demands
- Sequenced multi-boiler systems that employ relatively small storage tanks are ideal for applications with constant, yet fluctuating hot water demands

Multi-Tank Systems

- For applications with low ceiling heights or unique installation challenges

Electric Back-Up

- Heavy-duty electric water heater elements and controls can be specified for up to 3,000 kW for 100% electric back-up
- Provides hot water even during natural gas curtailments

Superior I-Beam Skid

- For easy shipping
- Larger systems may be shipped on a split skid that is easily assembled during installation

Factory Hydrostatic And Fire-Tested Before Shipping

5-Year Heat Exchanger Module And 5-Year Limited Tank Warranty



Other Features

- CSA Certified and ASME rated T&P relief valve
- Tank temperature sensor
- Tank thermometer
- Isolation valves (Reliable ball valves)
- 125 PSI tank construction

Options

- All-bronze circulating pump
- Sequencing control panel for multi-boiler systems
- 150 PSI tank construction
- 11" X 16" manhole for easy maintenance
- Cement and epoxy tank linings available to meet special specifications
- Optional dual energy source capability

Shown below are standard Ac-U-Temp configurations* Custom designs are available to meet specific needs.

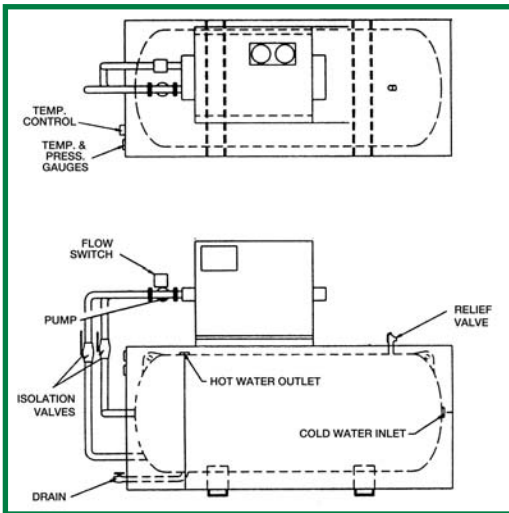

Genesis model stacked on a horizontal jacketed tank.

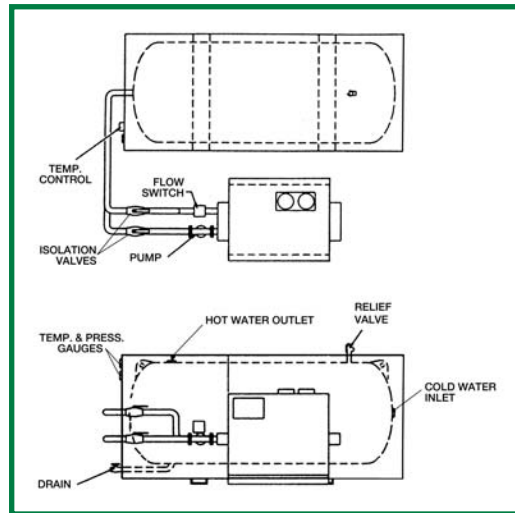

Genesis model placed in front of a horizontal jacketed tank.

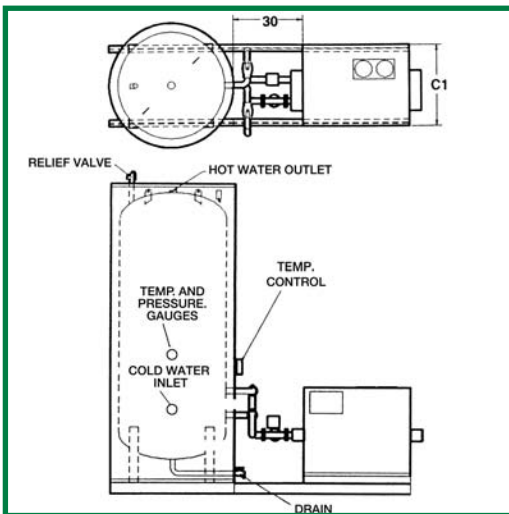

Genesis model with a vertical horizontal storage tank.

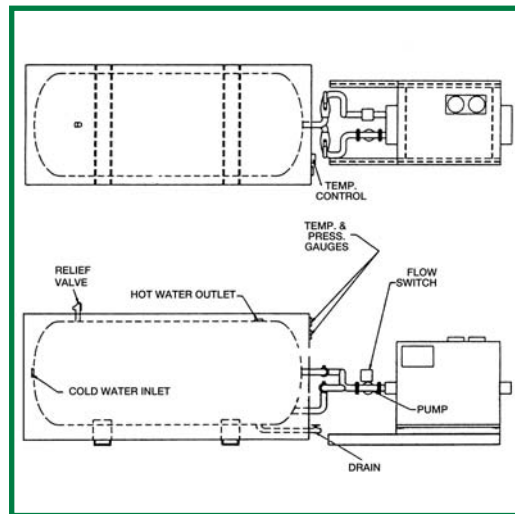

Genesis model skid mounted in line with a horizontal jacketed tank.

*The four examples shown feature the Genesis boiler with various piping configurations with a jacketed insulated tank.

Heavy-Duty Electric Dura-Power™ Hot Water NW Boiler Models

Designed for use as a hot water boiler for space heating applications



ASME



Optional Goldenrod® 24-carat gold-plated elements resist lime scale adhesion and sheath temperatures up to 1500° F.

ASME Code Construction

- All vessels manufactured to applicable ASME code
- Vessels with maximum working pressure of 160 PSI or less (standard design is for 125 PSI) at 240°F maximum temperature bear the "H" symbol

Incoloy Immersion Heaters

- Heavy-duty medium-watt density elements (3 per immersion heater)
- Incoloy sheathing provides excellent protection against oxidation and scaling
- Inputs range from 450 kW to 6,000 kW

Control And Power Circuit Fusing

- Meets National Electrical Code
- 100,000A I.C. cartridge-type fuses protect all elements and contactors

Pilot Switch And Light

- Permits manual starting and stopping of heater by interrupting power to the control circuit
- Pilot light indicates when control circuit is energized

Heavy-Duty UL-Rated Magnetic Contactors Rated For 100,000

Low Water Cutoff

- Probe type, electric low water cutoff prevent energizing of elements in the even of low water condition

120V Control Circuit

- Powered by fused transformer

Modulating Step Control

- Solid state modulating step control modulates heat input to match load

1-Year Limited Tank Warranty

All dimensions in inches

MODEL NO.	GAL. CAP.	KILO-WATTS MAXIMUM	HT.**	WIDTH	DEPTH	INLET AND OUTLET*	BOILER DRAIN
NW-37	37	180	42	32	30	3	1
NW-60	60	300	57	32	30	3	1
NW-96	96	480	69-1/2	36	38	4	1-1/4
NW-150	150	720	69-1/2	54	44	5	1-1/2
NW-220	220	1140	71	60	50	5	1-1/2
NW-334	334	1740	99	60	50	6	2
NW-400	400	2100	90-1/2	66	56	8	2
NW-500	500	2580	90-1/2	72	62	8	2
NW-670	670	3300	96-1/2	78	68	8	2

NOTE: For boilers 3400 kW to 6000 kW, consult factory.

*All fittings under 4" will be threaded type. All fittings 4" and larger will be flanged.

**Where overall height is a problem, a larger diameter vessel with a reduced height may be furnished.



Designed for utilizing steam or high temperature boiler water as an energy source

Steam or Boiler Hot Water HWG Generator Systems

These skid-mounted water heater systems are completely assembled and packaged for use. All components are sized, piped and checked at the factory before shipment. HWG systems save labor and time, requiring only connection to heat source.

Packages include pressure regulators, temperature regulators, steamtraps, strainers and other custom items such as standard or optional features.

Tank and heat exchanger capacities will closely match those now available, 80 through 12,500 gallons and 0.9 through 214 square feet of heat transfer.

Insulation

- Models are insulated with fiberglass to meet the most current ASHRAE standards

Integral Pump

- System includes an integral bronze circulator pump

Steam Units

- Standard steam trim consists of temperature control valve, inlet and auxiliary steam traps, inlet and auxiliary strainers, steam pressure gauge with siphon, vacuum breaker and air vent

Boiler Units

- Standard boiler water trim includes temperature control valve and boiler water temperature gauge

Cathodic Protection

- Standard systems employing glass, cement or epoxy-lined tanks are fitted with magnesium anodes to help prevent corrosion

Gallon Sizes

- HWG models are available from 140 gallons to 12,500 gallons in both vertical and horizontal configurations

Additional Features

- ASME Code (Section IV)
- All copper recirculation with two bronze ball valves
- Flush-mounted temperature gauges and pressure gauges
- National Board Stamped
- CSA Certified and ASME rated T&P relief valve
- Heating coil Section VIII of ASME code

5-Year Limited Tank Warranty And 1-Year Limited Coil Warranty

Options

- Storage Tanks:** 150# through 160# PSI working pressure, ASME Section VIII construction, 4" X 6" handhole, 11" X 15" manhole, cement, epoxy or galvanized linings
- Water To Water:** Pilot (spring, air, temperature) operated temperature regulator, bypass loop in boiler water line for regulator isolation
- Steam To Water:** Pilot (spring, air, temperature) operated temperature regulator, bypass loop in steam line for temperature regulator, vacuum breaker



ASME



For GPH recoveries, consult specification sheet.

Custom Semi-Instantaneous Water Heaters HWI Models

Boiler Water or Steam

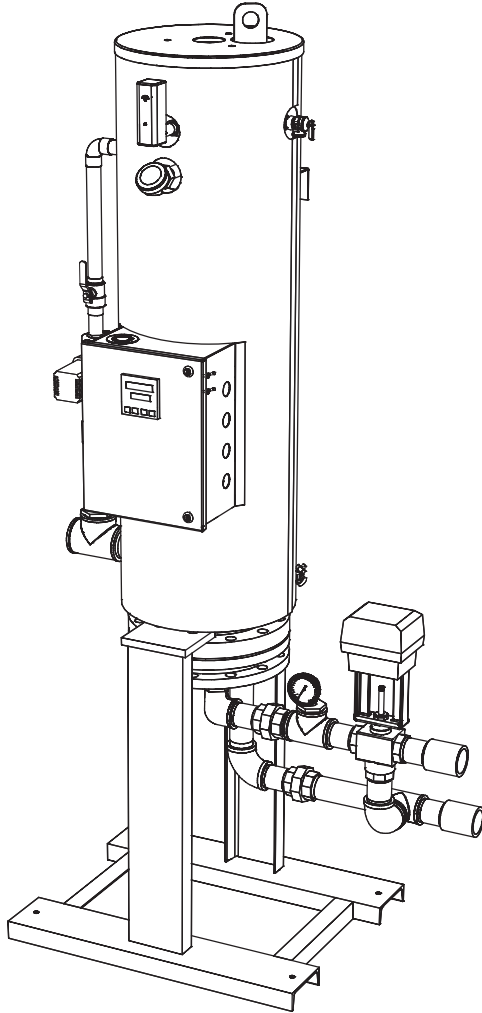

A. O. Smith's HWI models are available for operation with steam or boiler water as the energy source. They are factory assembled with components sized, piped and checked at the factory before shipment. HWI models are all space saving vertical models.

Control Features

- *Single Point Wiring*—Single 120V connection, controls including integral circulation
- *On/Off Switch*—Allows local on/off for service
- *Temperature Readout*—LED readout of water temperature
- *PID Temperature Control*—Modulates electrical control valve
- *Closes main valve if "over" temperature conditions exist*
- *Remote Temperature Signal*
- *Two-Wire RS485 Communication (MODBUS or ASCII)*

For additional information please call the factory with the following:

- *Required gallons per hour recovery needed*
- *Temperature rise needed; for example—40° to 140°*
- *Single or Double-Wall Coil*
- *If steam is the energy source, what is the steam pressure? For example—15 psi, 30 psi, etc.*
- *If boiler water is the energy source, what is the minimum boiler water temperature? For example - 180°, 140°, etc.*

Note: Orders cannot be processed until the above required information has been provided.





Custom Small and Large Volume Storage Tanks

Models (T, TL, TN ,TJ, TJV, TJH, TJVT)

These storage tanks are ideal for use with gas-fired copper heat exchanger equipment and other A. O. Smith hot water systems for storage of any potable water at temperatures of 180°F or lower. Sizes range from 80 to 12,500 gallons and custom models are available with special linings, heating coils (single-or double-wall), and accessories.

Glasslined Tank

- Internal surfaces exposed to water are glasslined per ASME, HLW procedures using an NSF approved glass-lining compound

Horizontal Or Vertical Mounting

- Except for TJ-80 (vertical only) and TL-500 (horizontal only)

Jacketed Tanks

- Tanks meet R12.5 minimum thermal insulation requirements of the U.S. Department of Energy and Current Edition of the ASHRAE/IESNA 90.1

Anodic Protection

- Magnesium anodes help extend tank life

ASME Construction

- Standard on TJV/TJH jacketed tanks; 100, 125, 150 & 160 PSI maximum working pressure available

5-Year Limited Tank Warranty

Options

- Manifold kits
- Flexible R-11 jackets for field installation
- Manholes/Handholes
- Factory-mounted temperature or pressure gauges
- Extended warranties
- Lifting lugs
- Military specifications

Other Linings Available

- Cement formulation provides excellent corrosion protection; available on 200-gallon and larger sizes
- Epoxy lining is suitable for cold or hot water storage; available on 200-gallon and larger sizes

Other Constructions

- Black steel, stainless and silicon bronze tanks are available for extreme severe or special applications; ASME is standard



ASME



Low Lead Content



Desired temperatures in A. O. Smith custom-lined hot water storage tanks can be maintained with special copper tube heating elements. Available for use with steam or boiler water, single- or double-wall construction.



Custom Tanks Built To Order For Any Need

A. O. Smith understands the variety of special needs you may have in designing a complete commercial hot water supply system. We can meet just about any need you specify, with our "HD" High-Draw Custom Storage Tanks from 80 to 10,000 gallons, all with ASME construction, and with an extensive menu of options, including:



- Cement, epoxy or glass linings
- Black steel tanks, stainless steel tanks, silicon bronze tanks
- Military specifications
- Manholes
- Handholes
- Lifting lugs
- Steam or hot water tank heaters
- Special and additional tank openings
- Ring and leg bases
- Horizontal tank saddles
- Factory-mounted temperature or pressure gauges



All dimensions in inches

BARE (UNINSULATED) STORAGE TANKS			
MODEL NO.	GAL.	APPROX. OVER-ALL DIMENSIONS DIA. X LENGTH	WORKING PRESSURE (PSI)
T-80 STD	80	20 X 62-1/8	150
T-80 ASME	80	26-1/2 X 57-7/8	150
T-120 STD	120	24 X 65	150
T-140 ASME	140	24 X 76-1/4	125
T-200 STD	200	30 X 72	150
T-200 ASME	200	30 X 72	125
T-250 ASME	250	30 X 84	125
T-350 STD	350	36 X 87-1/2	125
T-350 ASME	350	36 X 87-1/2	125
T-400 ASME	400	36 X 97-1/8	125
TL-500 ASME	500	36 X 121-3/4	125
TN-500 ASME	500	42 X 88	125
T-500 ASME	500	48 X 73	125
T-750 ASME	750	48 X 105-7/8	125
T-1000 ASME	1000	48 X 137-3/4	125

All dimensions in inches

VERTICAL JACKETED (INSULATED) STORAGE TANKS			
MODEL NO.	GAL.	APPROX. OVER-ALL DIMENSIONS DIA. X LENGTH	WORKING PRESSURE (PSI)
TJ-80 STD	80	20 X 62-1/8	150
TJ-80 ASME	80	26-1/2 X 57-7/8	160
TJV-120 ASME	119	26 X 61-3/4	160
TJV-120 M	119	29-3/8 X 62	160
TJV-140 ASME	140	30 X 87	125
TJV-200 ASME	200	36 X 83	125
TJV-200 M	175	32 X 77	125
TJV-250 ASME	250	36 X 93	125
TJV-350 ASME	350	42 X 99	125
TJV-400 ASME	400	42 X 105	125
TJVT-500 ASME	500	48 X 100	125
TJV-500 ASME	500	54 X 84	125
TJV-750 ASME	750	54 X 116	125
TJV-1000 ASME	1000	54 X 148	125

All dimensions in inches

HORIZONTAL JACKETED (INSULATED) STORAGE TANKS			
MODEL NO.	GAL.	DIM.	PRESSURE
TJH-200 ASME	200	36 X 77	125
TJH-250 ASME	250	36 X 90	125
TJH-350 ASME	350	42 X 93	125
TJH-400 ASME	400	42 X 99	125
TJHF-500 ASME	500	40 X 94	125
TJH-500 ASME	500	54 X 79	125
TJH-750 ASME	750	54 X 110	125
TJH-1000 ASME	1000	54 X 143	125

For complete specifications on A. O. Smith Commercial Storage Tanks, consult Specification Sheets at www.hotwater.com.

The industry's largest commercial product selection.

A. O. Smith's reputation for innovation continues to soar with our most complete line of products yet. With the trademark blend of innovative technology and energy-efficient solutions, our comprehensive line is the natural source for everything from the smallest commercial installation all the way up to the largest multi-structure complex.

We offer over 500 different commercial models, including gas fired, oil-fired and electric configurations, ranging in capacities from 5 to 10,000 gallons, with input range from 50,000 BTU to the equivalent of 2,500,000 BTU.

Through an inspired blend of innovation, efficiency and years of expertise, A. O. Smith continues to set the industry standard for performance and quality of water heaters, boilers and storage tanks.



No other company is better qualified to fill your hot water needs.

Knowledgeable people at your service.

To better serve our customers, A. O. Smith has over 200 manufacturer's representatives covering the United States and Canada. In addition, we have more than 400 factory-authorized service technicians to provide reliable, immediate warranty services. We also maintain a well-staffed Customer Care Facility in Ashland City, Tennessee, that can provide information on A. O. Smith products, sizing, competitive analysis, etc. A toll free number, (800) 527-1953 (M-F 7 a.m.–7 p.m. Central time), puts you in touch with the best technical information center anywhere.

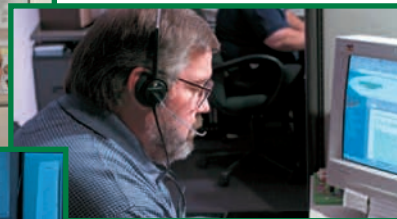

A. O. Smith Customer Care Center

"Our job is to 'smooth the road' from proper product selection to installation, and to help customers over the 'potholes' of troubleshooting service."



Complete replacement parts support.

Our Parts Department carries replacement parts for every product A. O. Smith manufactures. We offer expert parts support and a wide range of shipping options, including same-day delivery, where available. Our toll free parts order number, (800) 433-2545 is answered 7 a.m. to 5 p.m., Central time, Monday through Friday. The parts order fax, (800) 433-2515, is available 24 hours a day. Fax orders received after 5:00 p.m. will be fulfilled the following business day.

A. O. Smith has manufacturing facilities located worldwide.

Plants are located in strategic locations throughout the United States, providing timely shipments to wholesalers. In addition, manufacturing plants are also located in Nanjing, China, to supply the ever increasing demand for water heaters to the expanding Far East. Juarez, Mexico; Stratford, Ontario; and Veldhoven, The Netherlands provide commercial electric and gas energy-saving models.





A. O. Smith Water Products Company
500 Tennessee Waltz Parkway • Ashland City, TN 37015
PH 800.527.1953 • www.hotwater.com

*A. O. Smith reserves the right to make product changes
or improvements at any time without notice.*