

Application

Ideal for use where Lead-Free* valves are required. Designed for installation on potable water lines to protect against both backsiphonage and backpressure of contaminated water into the potable water supply. The Model 975XL2U provides protection where a potential health hazard exists.

Standards Compliance

- ASSE® Listed 1013
- IAPMO® Listed
- CSA® Certified
- AWWA compliant C511
- Approved by the Foundation for Cross Connection Control and Hydraulic Research at the University of Southern California
- Certified to NSF/ANSI 372* by IAPMO R&T
*(0.25% MAX. WEIGHTED AVERAGE LEAD CONTENT)

Materials

Main valve body	Cast Bronze ASTM B 584
Access covers	Cast Bronze ASTM B 584
Fasteners	Stainless Steel, 300 Series
Elastomers	Silicone (FDA approved) Buna Nitrile (FDA approved)
Polymers	Noryl™, NSF Listed
Springs	Stainless Steel, 300 series

Features

Sizes: 3/4", 1", 1-1/4", 1-1/2", 2"
 Maximum working water pressure 175 PSI
 Maximum working water temperature 180°F
 Threaded connections (FNPT) ANSI B1.20.1

Relief Valve discharge port:
 3/4" - 1" - 0.63 sq. in.
 1 1/4" - 2" - 1.19 sq. in.

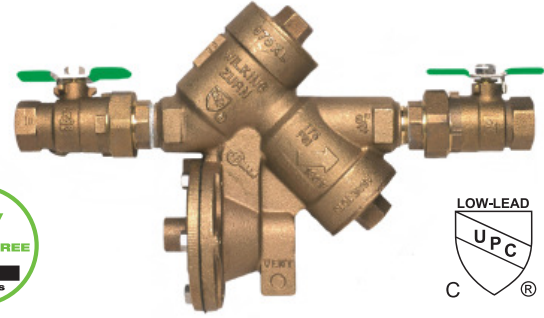

Options

- (Suffixes can be combined)
- with full port QT ball valves (standard)
 - BMS - with integral battery-operated relief valve monitor switch
 - MS - with integral relief valve monitor switch
 - S - with lead free bronze "Y" type strainer

Accessories

- Air gap (Model AG)
- Repair kits (rubber only)
- Thermal expansion tank (Mdl. XT)
- Soft seated check valve (Model 40XL2)
- Shock arrester (Model 1250XL)
- QT-SET Quick Test Fitting Set
- Test Cock Lock (Model TCL24)

Relief Valve discharge port:
 3/4" - 1" - 0.63 sq. in.
 1 1/4" - 2" - 1.19 sq. in.

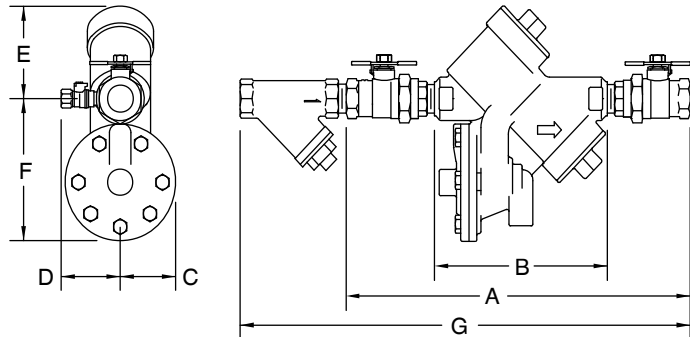

Dimensions & Weights (do not include pkg.)

MODEL SIZE	DIMENSIONS (approximate)														WEIGHT				
	A		B LESS BALL VALVES		C		D		E		F		G		LESS BALL VALVES	WITH BALL VALVES			
	in.	mm	in.	mm	in.	mm	in.	mm	in.	mm	in.	mm	in.	mm	lbs.	kg	lbs.	kg	
3/4	20	14	356	7 3/4	197	2 1/8	54	3	76	3 1/2	89	5	127	15 3/4	400	10	4.5	12	5.5
1	25	14 1/4	362	7 3/4	197	2 1/8	54	3	76	3 1/2	89	5	127	17 3/4	451	10	4.5	14	6.4
1 1/4	32	19	483	10 15/16	278	2 3/4	70	3 1/2	89	5	127	6 3/4	171	22	559	22	10	28	12.7
1 1/2	40	20	508	10 15/16	278	2 3/4	70	3 1/2	89	5	127	6 3/4	171	23 1/8	587	22	10	28	12.7
2	50	21 1/4	540	10 15/16	278	2 3/4	70	3 1/2	89	5	127	6 3/4	171	25 1/2	648	22	10	34	15.4

MODEL 975XL2U 3/4", 1", 1 1/4", 1 1/2" & 2" (STANDARD & METRIC)

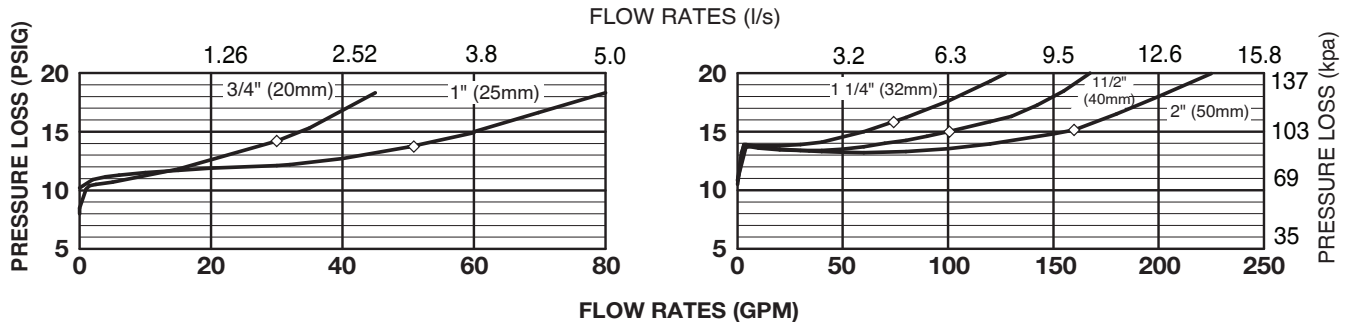

Typical Installation

Local codes shall govern installation requirements. To be installed in accordance with the manufacturers' instructions and the latest edition of the Uniform Plumbing Code. Unless otherwise specified, the assembly shall be mounted at a minimum of 12" (305mm) and a maximum of 30" (762mm) above adequate drains with sufficient side clearance for testing and maintenance. The installation shall be made so that no part of the unit can be submerged or where relief valve discharge could cause damage.

Capacity thru Schedule 40 Pipe				
Pipe size	5 ft/sec	7.5 ft/sec	10 ft/sec	15 ft/sec
1/8"	1	1	2	3
1/4"	2	2	3	5
3/8"	3	4	6	9
1/2"	5	7	9	14
3/4"	8	12	17	25
1"	13	20	27	40
1 1/4"	23	35	47	70
1 1/2"	32	48	63	95
2"	52	78	105	167

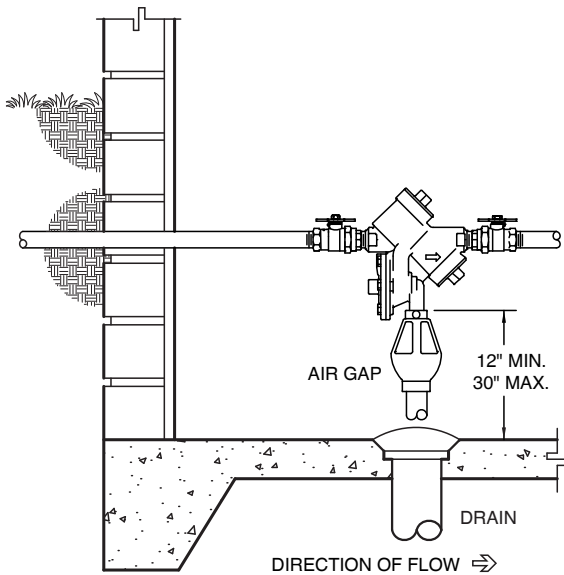

INDOOR INSTALLATION

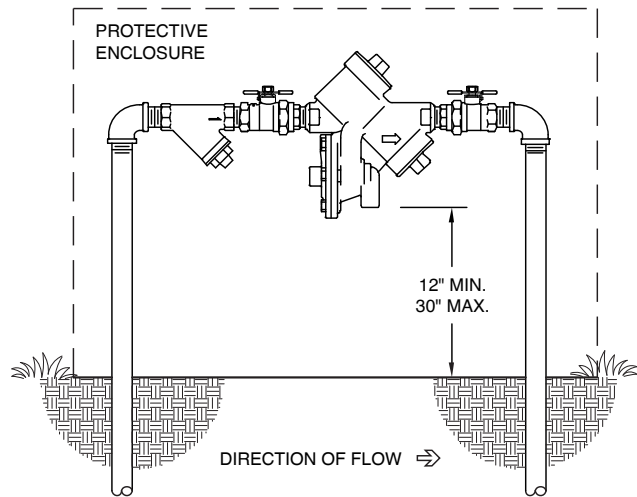

OUTDOOR INSTALLATION

Specifications

The Reduced Pressure Principle Backflow Preventer shall be certified to NSF/ANSI 372, shall be ASSE® 1013 Listed, rated to 180° F and supplied with full port union ball valves. The main body and access covers shall be low lead bronze (ASTM B 584), the seat ring and all internal polymers shall be NSF® Listed Noryl™ and the seat disc elastomers shall be silicone. The first check shall be accessible for maintenance without removing the relief valve. If installed indoors, the installation shall be supplied with integral monitor switch and air gap piped to a properly sized drain. The Reduced Pressure Principle Backflow Preventer shall be a ZURN WILKINS Model 975XL2U.