



# INDUSTRIES LIMITED

## Specification:

### AXIOM Industries Hydronic Mini System Feeder: MF200

Hydronic system feeder shall be AXIOM INDUSTRIES LTD. Model MF200. System shall include 25 litre (6.6 U.S. gallon) storage/mixing tank with molded-in level gauge, 125 mm (5") fill/access opening and cover; pump suction hose with inlet strainer and check valve; pressure pump with fuse protection; low fluid level pump cut-out float switch; manual diverter valve for purging air and agitating contents of storage tank; pressure switch with snubber and two sets of SPST dry contacts, each individually adjustable from 70 kPa (10 psig) to 170 kPa (25 psig) cut-out pressure; factory cut-out pressure set to 115 kPa (17psig); and liquid filled pressure gauge. Unit to be c/w UL listed and fused power supply adapter with LED power indicator light, 115/60/1 to 24 VDC 50 watts AC, supplied loose for field installation.

Feeder shall be compatible with glycol solutions of up to 50% concentration. Pump shall be capable of running dry without damage. The second set of contacts in the pressure switch shall be wired to a terminal strip for use as low pressure alarm contacts for remote alarm circuit supplied by others. Unit shall be completely assembled.

## OPTION

**MF200-1430** – Tank Mounting Shelf

**RIA10-1-SAA** – Low Level Alarm Panel c/w Remote Monitoring Dry Contacts and Selectable Audible Alarm. See RIA10-1-SAA product page for Alarm Panel Specifications

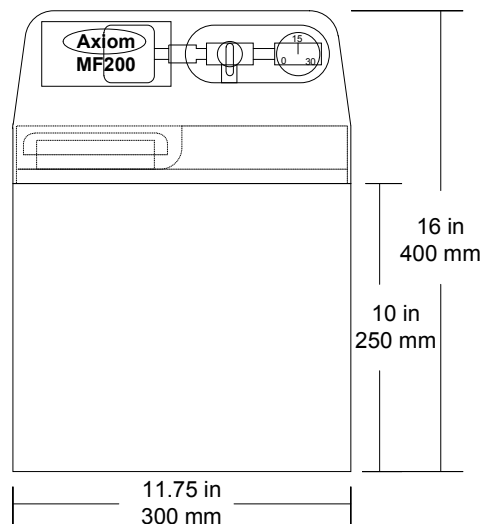

**Depth - 11.75 in 300 mm**  
**Clearances – Right Side - 12 in 305 mm**  
**Weight When Full 60 lbs/27 kg.**  
**Discharge 1/2" FPT**