

Minipumps are not designed to run dry as they are both cooled and lubricated by the water flowing through them. They therefore require a float switch to detect the presence of water in the drain pan and activate the pump only when water is present.

For this reason, a Minipump always consists of 2 elements:

- 1. The pump body**, which includes an electronic PCB and the pump motor.
- 2. The reservoir**, which contains the filter and the switching mechanism to activate the pump. This must always be kept level and clean to facilitate operation of the float switch and the filter must be cleaned regularly.

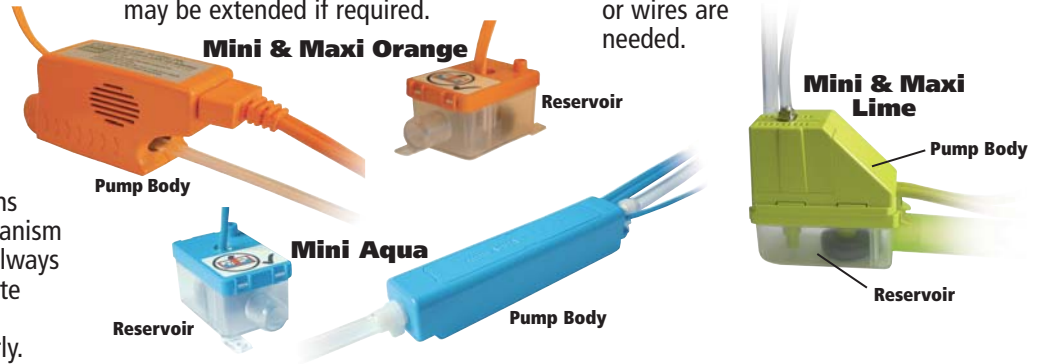

When these are supplied as 2 separate items as in the **Orange** or **Aqua** series, they are known as a **SPLIT TYPE PUMP** and the 2 elements are connected together with a length of 1/4" vinyl tube and a communication cable, both of which are usually around 6 feet long, but may be extended if required.

When these 2 elements are combined together in 1 unit as in the **Lime** series, they are known as a **MONOBLOC PUMP** in which the pump and reservoir share a common body and no connecting tubes or wires are needed.

**Both types are supplied with 2 incoming cables:**

- 1. A power supply cable**, which always has 3 conductors, color coded for different voltages in accordance with the NEC. Conductors for 115 volt pumps are white, black and green, and conductors for 230 volt pumps are red, black and green, and these colors are standard for all models which operate on line voltage.
- 2. An overflow alarm cable**, which is designed to break the communication wire between the condenser and the evaporator in case the water level in the reservoir rises to an unacceptable level. This cable also has 3 conductors, gray (common), purple (normally closed) and orange (normally open), and this color coding is identical for all pump models.

**CONNECTION OF THE OVERFLOW SWITCH IS MANDATORY. FAILURE TO DO SO WILL INVALIDATE MANUFACTURER'S WARRANTY AND ALMOST CERTAINLY LEAD TO FLOODING AND WATER DAMAGE.**

**NOTE:** The overflow switch contacts are a separate volt-free circuit which operates entirely independently from the power circuit that automatically switches the pump on and off as the water level rises or subsides.

**NOTE ALSO that the overflow switch is electronic and draws its power directly from the PCB in the pump, so the switch itself cannot operate**

**unless the pump is powered.**

**NOTE: The overflow switch is designed for a maximum load of 5 amps up to 230 volts, which is normally more than enough for most Minisplits as the current and the voltage carried in the communication wire are usually well below this.**

Standard wiring diagrams for most Minisplit manufacturers are available at [WWW.EZTRAP.COM](http://WWW.EZTRAP.COM) or [WWW.ASPENPUMPSUSA.COM](http://WWW.ASPENPUMPSUSA.COM) for download, or can be emailed or faxed on request.

If the 5 amp limit is exceeded, it will be necessary to use a single pole switching relay to handle this current to prevent the electronics in the pump from burning out. Specific wiring diagrams for this type of installation are available from EZ-TRAP on request.

Some Minisplits have communications wires which are sensitive because they utilize proprietary operating protocols, and these may have to be wired in a different way. In these cases the overflow switch must be wired only according to a wiring diagram dedicated to that particular manufacturer and/or model series.

Specific wiring diagrams for this type of installation are also available from EZ-TRAP on request.

Some Minisplits include a dedicated set of contacts on the PCB in the evaporator into

which the overflow wires can be connected as per the specific wiring diagrams provided by that manufacturer, and if an overflow does occur, the unit will automatically turn off and an alarm LED will flash on the control panel of the unit. If this is not the case and an external audio or visual alarm is required, this can easily be done by connecting the orange wire which is energized only when the water level in the reservoir becomes abnormally high.

In order to connect an external alarm, it is necessary for the communication wire to carry a stable AC voltage anywhere between 12 and 230 volts.

If an external alarm is required, the orange wire would be connected to one terminal of the alarm device which must use the same voltage as the communications wire, which will have to be determined prior to installation. If no external alarm is required, the orange wire is not used and the end is taped off to isolate it.

If the alarm device is powered by 12 to 115 volts, it will be necessary to connect the other terminal of the alarm device to a neutral to complete the circuit.

If the alarm device is powered by 230 volts, it will be necessary to determine the polarity of the communication wire (line 1 or line 2) and then to connect the other terminal of the alarm device to the other line (1 or 2) to complete the circuit.

If the current in the communication wire is low voltage electronic or DC, it will generally be difficult or impossible to isolate the other leg required to operate an alarm, and in this case, the orange wire is simply taped up and not used.

**Connection details for an external alarm will be found in diagram A below.**

Generally, most installers do not connect up an external alarm and this is why our wiring diagrams show the orange wire being taped off and not used.

**NOTE THAT THE OVERFLOW ALARM CIRCUIT NEVER DEACTIVATES THE PUMP WHICH REMAINS LIVE AT ALL TIMES.**

The power supply to the pump should always be connected to the incoming power terminal block on the evaporator to ensure that the pump is powered whenever the evaporator is powered.

It is not a good idea to hard wire the pump from a separate circuit, or to power it from a receptacle like a conventional tank pump because either of these can be inadvertently isolated or the plug could be accidentally removed.

In either case the evaporator would continue to produce water, but there would be no power to operate the pump or the overflow switch, so a flood would occur and this is unacceptable.

In spite of this, some local codes actually call for this type of wiring connection and if local code officials insist, this requirement will have to be met even though it may contradict the Aspen wiring instructions.

Some codes also require a disconnect close to the evaporator and, if this is installed, sometimes the pump is powered directly from the disconnect. **In this case, it is vital that the pump is powered**

**from the outgoing terminals on the disconnect, not the incoming ones, to ensure that if the evaporator is isolated, the pump will be isolated as well.**

**Details of this will be found in diagram B below.**

All manufacturers of Minisplit air conditioners use different wiring protocols, so the communications wire varies from one unit to another, as well as from one model to another, and for this reason, all wiring diagrams in the installation manuals are generic.

**Consult EZ-TRAP for factory approved wiring diagrams for all the major manufacturers. These can be found on WWW.EZTRAP.COM or WWW.ASPENPUMPSUSA.COM or can be emailed or faxed on request.**

All pump models incorporate a filter in the reservoir which must be cleaned regularly. **A detailed explanation of this will be found in diagram C below.**

All pump models require a mandatory breather tube to prevent an airlock in the reservoir while the pump is operating. **A detailed explanation of this will be found in diagram D below.**

ASPEN Mini models are available in 24V, 115V and 230V AC.

ASPEN Maxi models are available in 115V & 230V AC only.

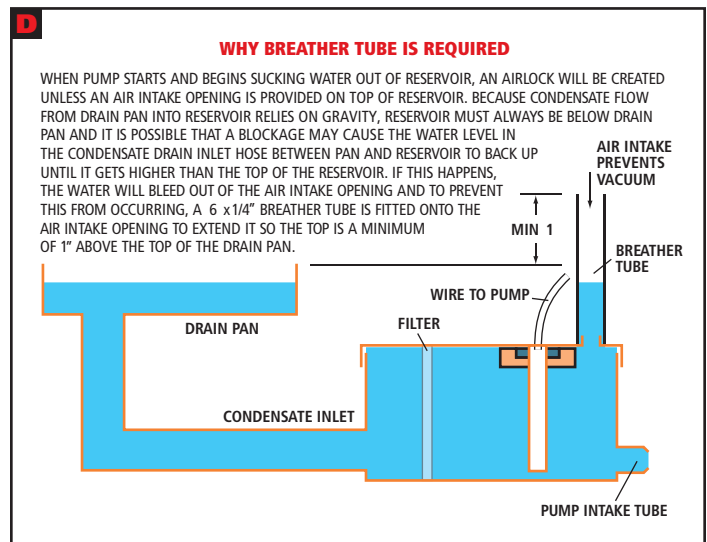
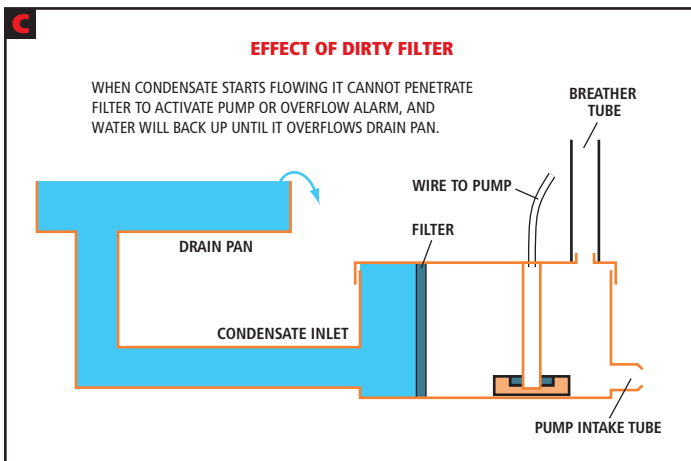
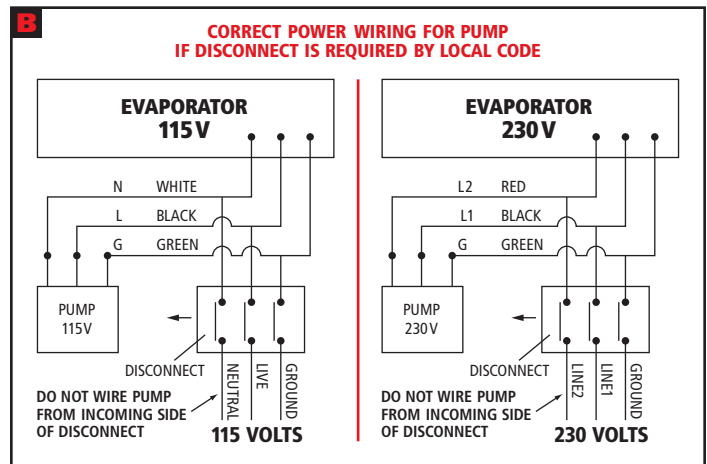
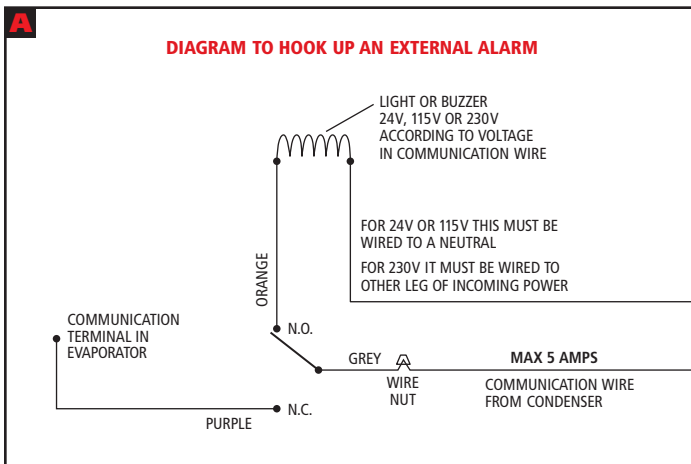

**Regardless of type or size, all ASPEN Minipumps (Mini & Maxi Lime, Mini & Maxi Orange, and Mini Aqua) share an identical operating sequence:**

**1. Pump is in Standby Mode:**

Unit is not operating, float rests on bottom of reservoir, overflow switch status is normal so contacts across gray and purple wires are closed and communication wire from condenser to evaporator remains energized.

**2. Pump enters Operation Mode:**

The evaporator produces water which flows into the drain pan and through the drain hose into the reservoir lifting the float 3/4" which automatically activates the pump.

Pump continues operating until water level recedes, float returns to the bottom of the reservoir, at which point the pump automatically switches off.

Overflow switch status is normal so contacts across gray and purple wires are closed and communication wire from condenser to evaporator remains energized.

This cycle will repeat indefinitely as long as water level in reservoir stays within normal limits.

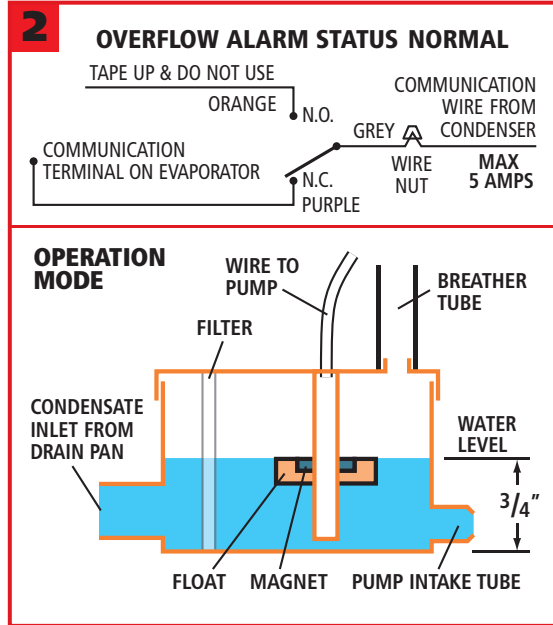
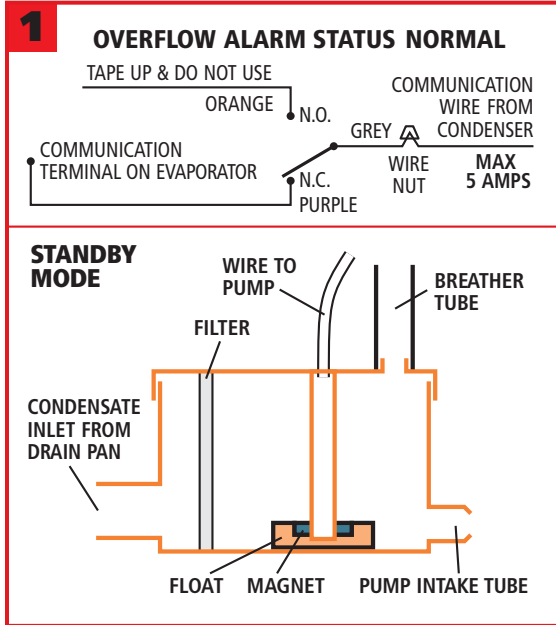

**3. Pump enters Alarm Mode:**

The evaporator produces water which flows into the drain pan and through the drain hose into the reservoir lifting the float 3/4" which automatically activates the pump. Even though pump is operating, water level continues to rise because of pump failure, blockage or insufficient capacity of pump.

Water level reaches 15/16", overflow switch operates changing status to abnormal.

Pump remains activated but contacts across gray and purple wire open, de-energizing communication wire to evaporator so it can no longer operate.

This prevents unit from creating any more water and raises an alarm because occupant will soon notice that AC is not operating and will contact service

tech to investigate.

Normally open contacts (gray and orange) close, current flowing into the evaporator from the condenser is now diverted to energize the orange wire which is normally taped off, but may also be wired into an external alarm if desired (see diagram A).

**4. Pump reverts to Standby Mode:**

Once reason for high water level has been diagnosed and corrected, pump reverts to standby mode, unit not operating, float rests on bottom of reservoir, overflow switch status is normal so contacts across gray and purple wires are closed and communication wire from condenser to evaporator remains energized.

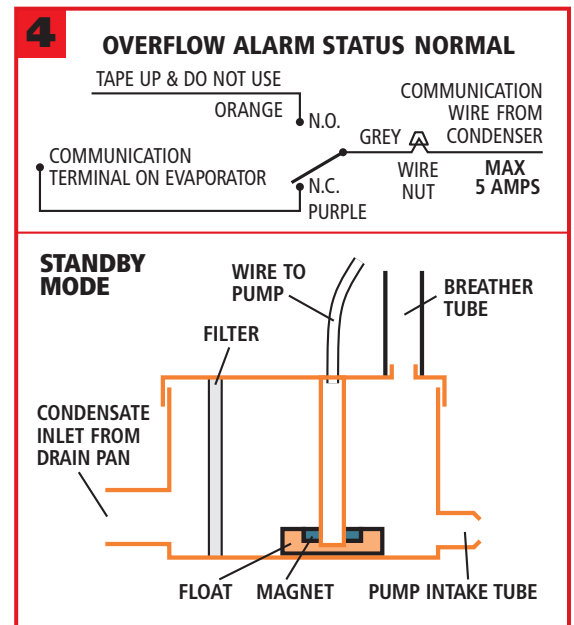
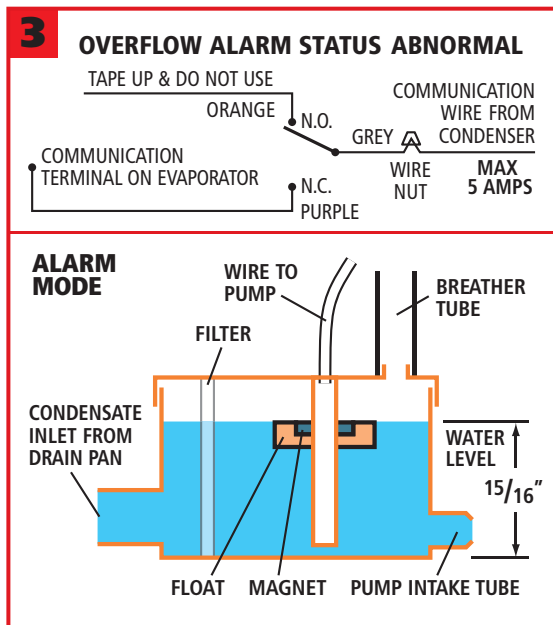

# EZ TRAP

## ASPEN PUMPS ASPEN SELECTION SPECIFICATIONS

Mini & Maxi Lime  
Kit Installed



Mini & Maxi Lime  
Lefthand



Mini & Maxi Lime  
Righthand



Mini & Maxi Lime  
OEM Kit - Pump Only

### ASPEN LIME SERIES EXTERNALLY MOUNTED MONOBLOC PUMPS FOR SIDE ENTRY EVAPORATOR INSTALLATIONS

LINE SET SIZE	COLUMN 1 UP TO 30,000 BTUS/HOUR		COLUMN 2 30,000 TO 60,000 BTUS/HOUR	
	UP TO 3/8" & 5/8"	UP TO 1/2" & 3/4"	UP TO 3/8" & 5/8"	UP TO 1/2" & 3/4"
HEAD	0-26 feet	26-49 feet	0-26 feet	26-49 feet
115 VOLT	ASP-ML-115	ASP-MLS-115	ASP-MAXLS-115	ASP-MLOEM-115
230 VOLT	ASP-ML-230	ASP-MLS-230	ASP-MAXLS-230	ASP-MLOEM-230
24 VOLT	ASP-ML-LG24	N/A	ASP-MLS-LG24	ASP-MLOEM-LG24

### ASPEN ORANGE & AQUA SERIES SPLIT TYPE PUMPS

HEAD	COLUMN 1 UP TO 24,000 BTUS/HOUR		COLUMN 2 24,000 - 60,000 BTUS/HOUR	
	0-26 feet	26-65 feet	0-26 feet	26-65 feet
ORANGE 115 VOLT	ASP-MO-115	ASP-MAXO-115	ASP-MAXO-115	ASP-MAXO-115
ORANGE 230 VOLT	ASP-MO-230	ASP-MAXO-230	ASP-MAXO-230	ASP-MAXO-230
ORANGE 24 VOLT	ASP-MO-LG24	N/A	N/A	N/A
AQUA 115 VOLT	ASP-MA-115	N/A	N/A	N/A
AQUA 230 VOLT	ASP-MA-230	N/A	N/A	N/A
AQUA 24 VOLT	ASP-MA-LG24	N/A	N/A	N/A

**NOTE: Pump capacity is calculated at full design voltage. Operation at reduced voltage will affect pump performance. When selecting pump capacity ascertain actual input voltage and ALWAYS DESIGN FOR WORST CASE SCENARIO!**



Mini Aqua

### MINI & MAXI ORANGE SYSTEM LOCATION

- 1 above lineset cover
- 2 inside evaporator casing where access permits
- 3 inside evaporator casing where access permits

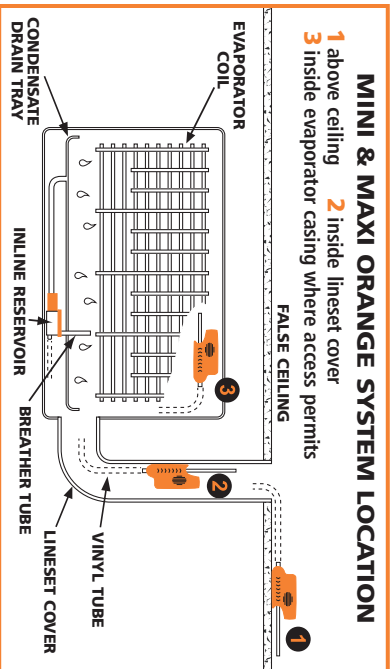

Mini & Maxi  
Orange



### MINI AQUA SYSTEM LOCATION

- 1 inside evaporator
- 2 inside lineset cover

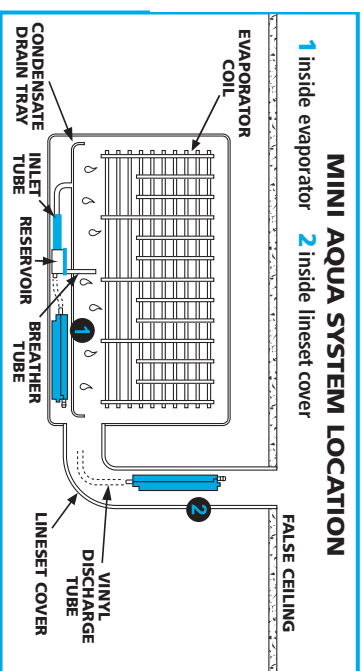

Imported and Distributed by



3 Kellogg Court, Unit 10, Edison, NJ 08817 • www.eztrap.com  
phone 732-248-8066 • fax 732-248-8068 • email: info@eztrap.com