

# Installation & Maintenance Instructions

## HYDRAMOTOR® PUSH-TYPE LINEAR ACTUATOR WITH WATERTIGHT ENCLOSURE

**AH2D  
SERIES**

I&M No.V8714R1 – Sec. 1  
(Section 1 of 2)

### ⚠ WARNING

To prevent the possibility of death, serious injury or property damage, the Hydramotor® Actuator must be installed and serviced only by a qualified service technician avoiding the following hazards:

- **Electrical hazard.** Turn off all electrical power to Hydramotor® Actuator. More than one circuit may exist.
- **Pressure hazard.** Depressurize valve and vent hazardous or combustible fluid to a safe area before inspection or removing the actuator or valve from service.
- **Explosion, fire or toxic gas hazards.** Extinguish all open flames and avoid any type of sparking or ignition during leakage testing.

### Service Notices

These instructions are divided into two sections. Be sure to read, understand and follow all instructions on I&M No. V8714R1 – Section 1 and 2.

See separate V710 Gas Valve Installation and Maintenance Instructions for information on: Operation, Positioning, Mounting, Piping, Strainer or Filter Requirements, Flow Controls, Preventive Maintenance, and Cause of Improper Operation.

### DESCRIPTION

AH2D Hydramotors® are self-contained linear, push-type actuators which extend when powered and retract by spring force upon power interruption.

The AH actuator is typically used for control of gas-fired heating equipment, commonly to open and close a valve or both a valve and damper. AH2D actuators position V710 Series gas valve assemblies.

### OPERATION

Application of electrical power simultaneously drives an electric pump and closes a normally-open dump valve, resulting in up to 250 pounds of force on the actuator stem. This extends the actuator stem and attached valve poppet, to open the valve and/or damper.

Upon reaching the fully extended position, a travel limit switch interrupts power to the electric motor while maintaining power to the dump valve, thus stabilizing hydraulic pressure to hold shaft position. Position indicators on both sides of the actuator show the actual position of the valve stem.

Upon power interruption, the dump valve opens releasing hydraulic pressure, allowing the return spring to retract the stem and close the valve fully. Closing time is one second or less.

### OPTIONAL FEATURES

- **Damper Shaft Arm** All components to mount damper arm on right side of actuator. Available with or without return spring.
- **Auxiliary Switch** One or two integral SPDT switches, field adjustable to actuate at any position of stroke.
- **Overtravel Proof-of-Closure Switch** A single factory set non-field adjustable SPDT switch to be used in conjunction with V710 Series Gas Valves with overtravel seal (V22 or V25 suffix in catalog number).

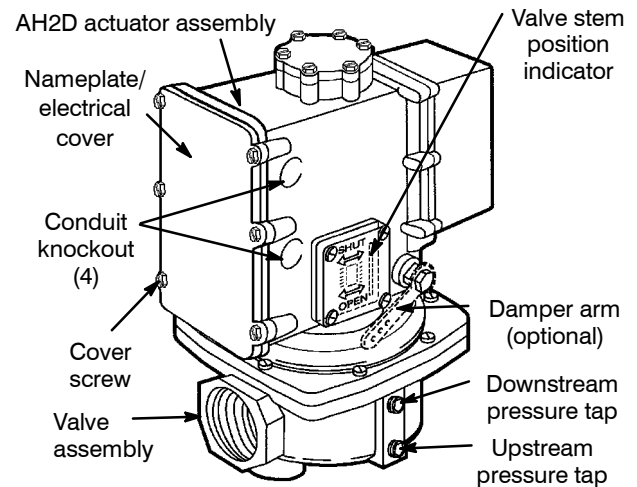

Figure 1. AH2D Actuator (shown mounted on V710 Series Gas Valve)

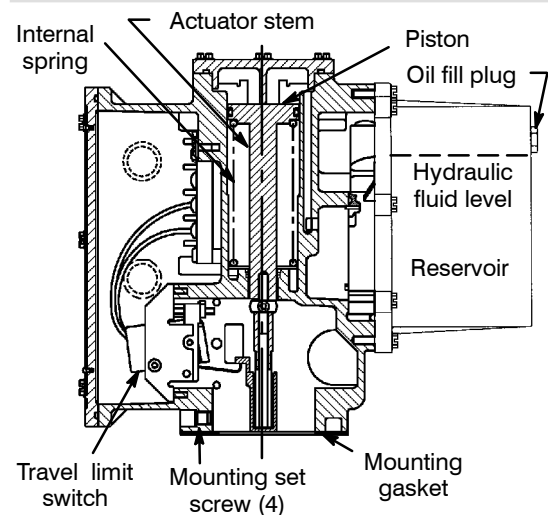

Figure 2. Cutaway View (de-energized)

## SPECIFICATIONS

**Force Output:** 250 lbs

**Stroke:** 1 1/8" maximum

**Electrical Characteristics:**

Operating Voltage *	Amperes (nominal)		
	Inrush	Running	Holding
24V/50–60Hz	28.00	8.00	0.73
120V/50–60Hz	5.60	1.85	0.11
240V/50–60Hz	2.80	0.92	0.05

\*50 Hz construction increases opening time 20%.

**Opening Time:** Fast Opening: 6 to 14 seconds  
Slow Opening: 14 to 26 seconds

Note: Opening time doubles between  $-30^{\circ}\text{F}$  to  $-40^{\circ}\text{F}$  ( $-34^{\circ}\text{C}$  to  $-40^{\circ}\text{C}$ ). Timing not field adjustable.

**Maximum Closing Time:** One second

**Temperature Limitations:** Ambient  $-40^{\circ}\text{F}$  to  $150^{\circ}\text{F}$  ( $-40^{\circ}\text{C}$  to  $66^{\circ}\text{C}$ )

**Damper Arm Rating:** Drives damper in one direction only. 20 lb maximum at 2.85 in. radius at  $20^{\circ}\text{F}$  to  $150^{\circ}\text{F}$  ( $-7^{\circ}\text{C}$  to  $65^{\circ}\text{C}$ ) and 10 lb maximum at  $-40^{\circ}\text{F}$  to  $20^{\circ}\text{F}$  ( $-40^{\circ}\text{C}$  to  $-7^{\circ}\text{C}$ ).

**Damper Arm Travel:** 2" maximum

## INSTALLATION

Before installation, check nameplates to verify actuator and valve selected are appropriate for the application. **IMPORTANT: After actuator installation, test all functions and check out complete system before putting actuator/valve into service.**

### Positioning/Mounting

Follow the V710 Series Gas valve and/or damper manufacturer's instructions when installing the Hydramotor®.

1. AH2D actuators can be installed to operate in any position.
2. Install mounting gasket and position the actuator to operate the valve (and damper if appropriate). Secure actuator with the four mounting set screws. Torque set screws to  $80 \pm 5$  in-lbs [ $9,0 \pm 0,5$  Nm] using a 5/32" hex key wrench.
3. For damper applications requiring the damper arm to return upon power failure, the optional return spring and spring plug (kit 440018) must be installed on the damper arm. Connect linkage so that damper returns to the desired position.

**Wiring** (Refer to Figure 3)

**⚠ WARNING: Electrical hazard. To prevent the possibility of death, serious injury or property damage, open all circuits before inspection, service or disassembly. Reassemble before operating.**

Wiring must comply with local codes and the National Electrical Code. Limit controls must conform to actuator rating (voltage, amperage, hertz). Wiring to meet NEC Class I, suitable for  $75^{\circ}\text{C}$ . Wire limit controls to the hot side of power supply.

1. Route wiring through one of the conduit knockout openings. Install appropriate electrical fittings.
2. For 120 VAC, connect the power wiring to terminals N (neutral) and L1 (hot). For 240 VAC, connect the power wiring to terminals L2 and L1 (hot). A green grounding screw with a cup washer is provided beside the terminal strip for grounding.
3. Torque terminal screws to 8 to 12 in-lbs [0,9 to 1,3 Nm].
4. Connect auxiliary or valve overtravel proof-of-closure switch wiring to the common and normally open or normally closed switch terminals.
5. Install nameplate/electrical cover with gasket and screws (6) on actuator housing. Hand thread screws as far as possible, then torque screws evenly in a crisscross manner to 30 to 35 in-lbs [3,4 to 4,0 Nm].
6. Operate actuator (complete system) through five cycles to verify proper operation.

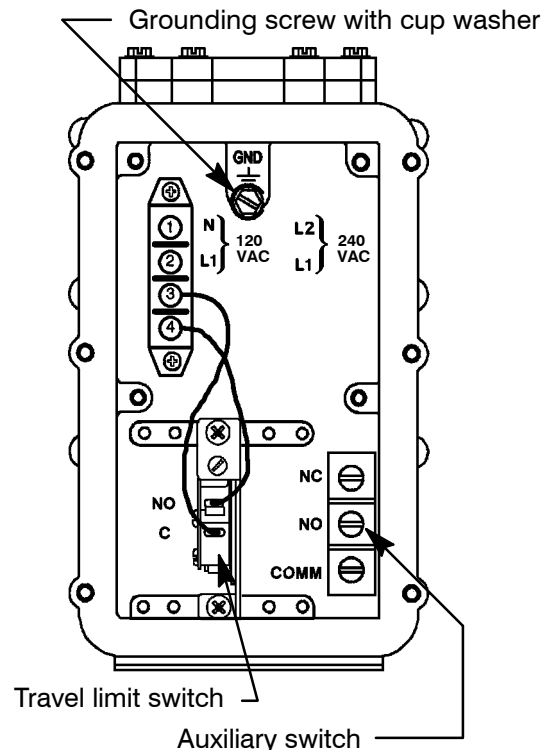

Figure 3. Typical AH2D Actuator Wiring.

### Auxiliary and Overtravel Proof-of-Closure Switch Ratings

15 Amps 120 Vac  
7.5 Amps 240 Vac

Total connected load of auxiliary and overtravel proof-of-closure switches not to exceed 1800 VA.

**⚠ CAUTION: Overtravel Proof-of-closure switch must only be used with V710 Series Gas Valves having an overtravel seal (V22 or V25 Suffix in catalog number).**

## Overtravel Proof-of-Closure Switch

The optional valve overtravel proof-of-closure switch is set at the factory to provide both a mechanical and electrical means of proving valve closed position interlock to the primary control. This switch is not to be field adjusted.

### Optional Auxiliary and Overtravel Proof-of-Closure Switch Combinations (Partial Views)

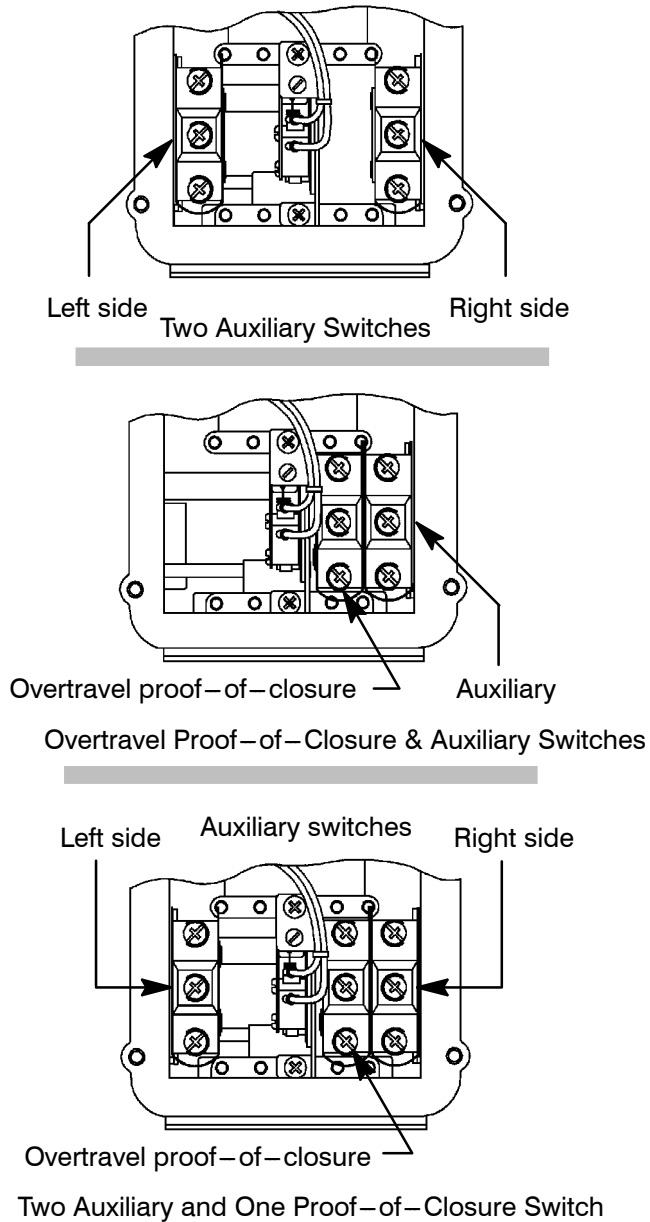

### Auxiliary Switch Adjustment (Refer to Figure 4)

1. Remove window screws(4) and window with gasket.
2. Loosen the camlock screw no more than 1/2 turn.
3. Reset the cam adjustment screw to the desired switching point and hold this screw until camlock screw is tightened.
4. Tighten the camlock screw. Cycle the actuator to verify the switch setting and readjust as required.
5. Reinstall the window with gasket and torque screws evenly to 14 to 16 in-lbs [1,6 to 1,8 Nm].

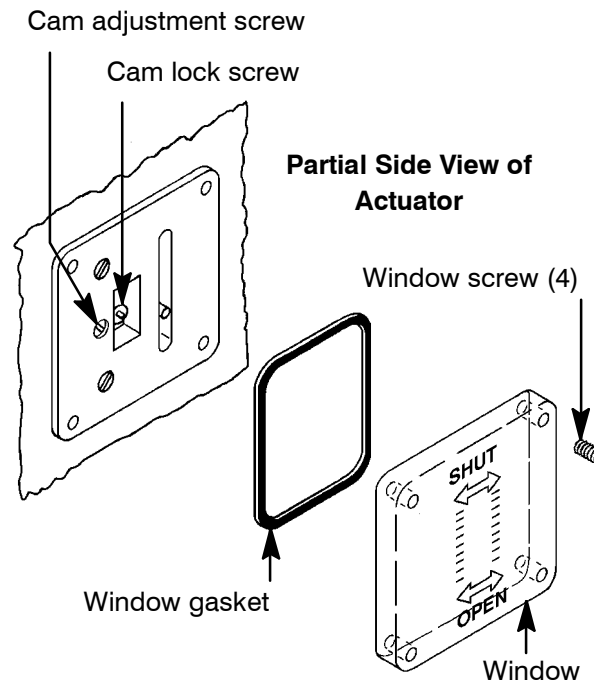

Figure 4. Auxiliary Switch Adjustment.

## MAINTENANCE

Maintenance should include annual inspection and cleaning. Use a cleaning fluid compatible with actuator components to remove dirt and oil. Organize a maintenance schedule based on environment and frequency of use. Check for loose electrical and mechanical connections and replace damaged parts. **Before inspection, maintenance or rebuild, review WARNING statements on page 1.**

### Field Service Notice

**Field service replacement kits are limited to the following:**

1. Travel limit switch Replacement Kit 440014.
2. Left side auxiliary switch Replacement Kit 440002.
3. Right side auxiliary switch Replacement Kit 440003.
4. Overtravel proof-of-closure switch Replacement Kit 440004\*.
5. Right side combination auxiliary and overtravel proof-of-closure switch Replacement Kit 440012\*.
6. Damper arm Replacement Kit 440018 (with spring and spring plug) or 440019 (without spring and spring plug).
7. Oil Replacement Kit 440008.
8. All gaskets and screws for enclosure Replacement Kit 440020. This kit contains the following:
  - Nameplate/electrical cover gasket and screws
  - Right & left window gasket and screws.
  - Valve/actuator mounting gasket and mounting set screws.

To order, specify the kit or part number, as well as the actuator model and serial numbers.

\*Separate instructions provided with replacement kit.

### Travel Limit Switch Replacement (Refer to Figure 5)

1. Remove the six cover screws and nameplate/electrical cover with gasket.
2. Disconnect wiring from travel limit switch.

#### **CAUTION: Label wires before disconnecting.**

3. Remove two mounting screws and the travel limit switch.
4. Reinstall new travel limit switch in actuator. Torque mounting screws (2) evenly to 20 to 25 in-lbs [2,3 to 2, 8 Nm].
5. The required stroke is  $1\ 1/8'' \pm 1/16''$ . Turn adjustment screw located above limit switch until the desired stroke is achieved. Turn the adjustment screw clockwise to decrease stroke and counterclockwise to increase stroke.
6. Operate actuator (complete system) through five cycles to verify proper operation.
7. Reinstall nameplate/electrical cover with gasket and screws (6) on actuator housing. Hand thread screws as far as possible, then torque screws evenly in a crisscross manner to 30 to 35 in-lbs [3,4 to 4, 0 Nm].

### Auxiliary Switch Replacement (Refer to Figure 6)

1. Remove six cover screws and nameplate/electrical cover with gasket.
2. Disconnect auxiliary switch wiring.

#### **CAUTION: Label wires before disconnecting.**

3. On auxiliary switch side of actuator, remove window screws (4) and window with gasket.
4. Remove auxiliary switch mounting screws (2) from side of actuator.
5. Disengage auxiliary switch from indicator bar and remove switch from actuator.
6. Install new auxiliary switch and reassemble in reverse order of disassembly.
7. Torque auxiliary switch mounting screws (2) evenly to 14 to 16 in-lbs [1, 6 to 1,8 Nm].
8. Torque terminal screws 8 to 12 in-lbs [0, 9 -1, 3 Nm].
9. Reinstall the window with gasket and torque screws evenly to 14 to 16 in-lbs [1,6 to 1,8 Nm].
10. Reinstall nameplate/electrical cover with gasket and screws (6) on actuator housing. Hand thread screws as far as possible, then torque screws evenly in a crisscross manner to 30 to 35 in-lbs [3,4 to 4, 0 Nm].
11. Operate actuator (complete system) through five cycles to verify proper operation.

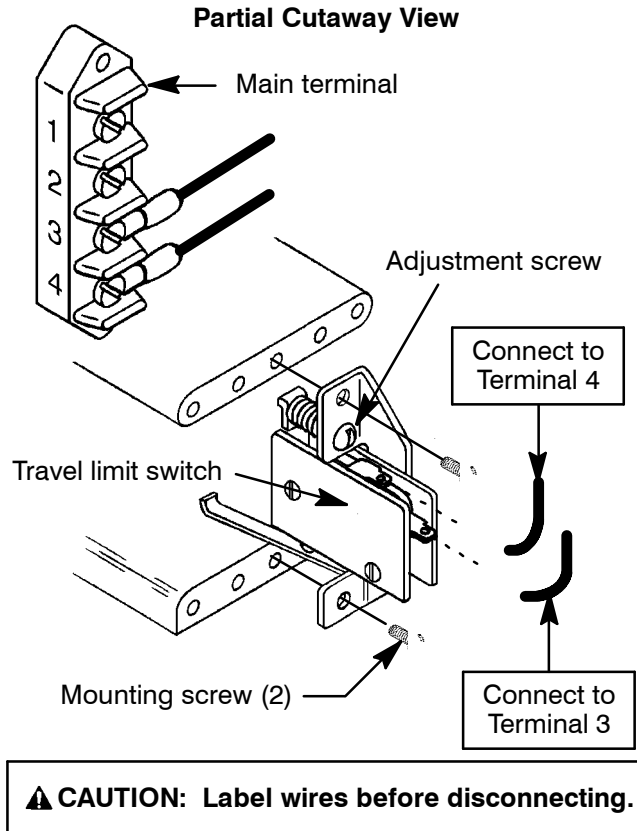

Figure 5. Travel Limit Switch Replacement.

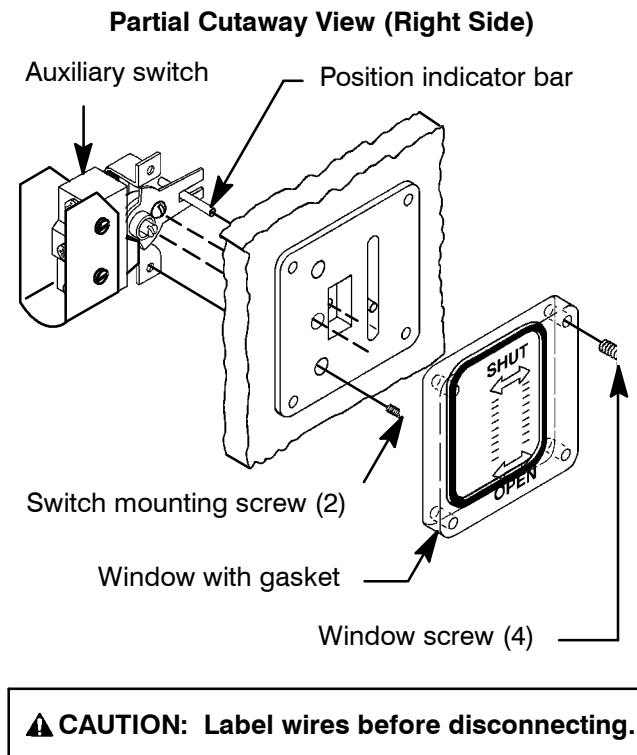

Figure 6. Auxiliary Switch Replacement.

Continued on I&M No. V8714R1 -- Section 2.

# Installation & Maintenance Instructions

## HYDRAMOTOR® PUSH-TYPE LINEAR ACTUATOR WITH WATERTIGHT ENCLOSURE

AH2D  
SERIES

I&M No.V8714R1–Sec. 2  
(Section 2 of 2)

**Notice:** These instructions are divided into two sections. Be sure to read, understand and follow all instructions on I&M No. V8714R1 – Section 1 and 2.

### Damper Shaft Arm and Spring Replacement

(Refer to Figure 7)

1. Disconnect damper shaft arm from existing system linkage.
2. Remove retaining ring from end of damper shaft.
3. Slip damper shaft arm, spring plug and return spring (if present) off damper shaft.
4. Reassembly in reverse order of disassembly paying careful attention to exploded view in Figure 7.
5. Reconnect existing system linkage to damper shaft arm.
6. Operate actuator (complete system) through five cycles to verify proper operation.

Note: Damper shaft arm replacement kits are supplied with or without return spring and spring plug. See *Field Service Notice* in Section 1 page 3 of 6.

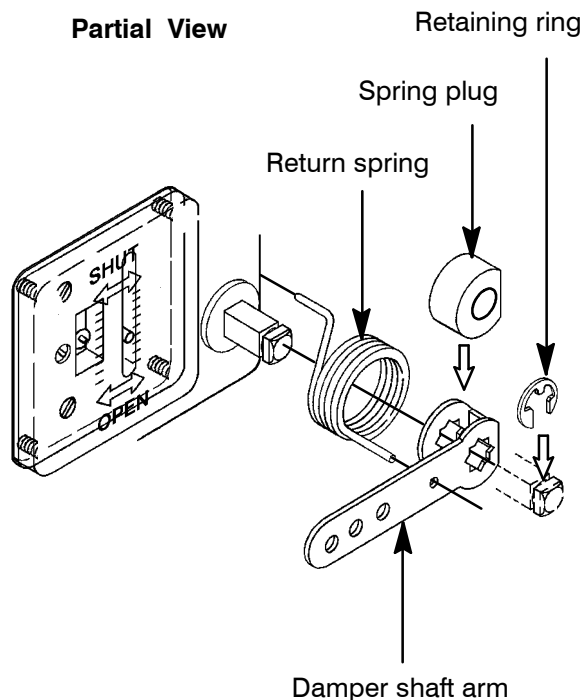
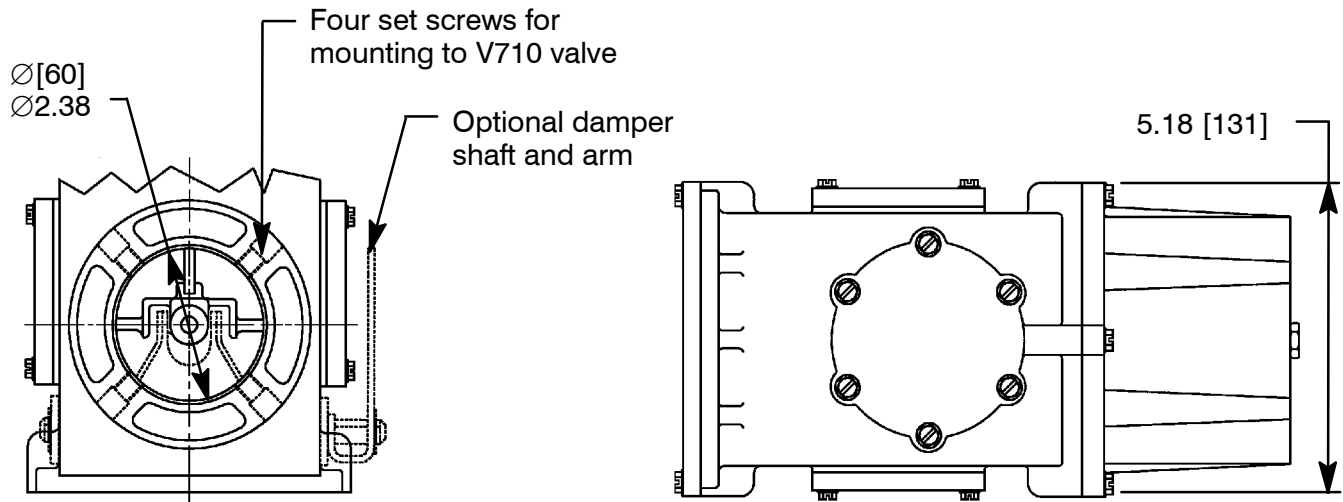

Figure 7. Damper Shaft Arm & Return Spring.

### Refilling Hydramotor® Actuator with Hydraulic Oil and Purging Entrapped Air

1. When refilling a Hydramotor® Actuator with oil, it is recommended that the actuator be energized and de-energized during filling (if possible). This is particularly important if the oil level in the reservoir is very low or empty. By operating the actuator, entrapped air is purged from the hydraulic system. If upon energizing the Hydramotor® Actuator the actuator fails to move, delays or operates slowly, chances are air has become entrapped in the hydraulic system. Remove entrapped air from the hydraulic system by cycling the actuator 4 to 5 times successively over the full stroke. As air is purged, check oil level and add oil if necessary. All of the air has been removed when the actuator stem moves immediately upon energizing.
2. *With Actuator Mounted Upright*, (Figure 2), remove oil fill plug and fill to bottom of fill port, follow instructions provided in step 1.
3. *With Actuator Mounted On Its Side*, and oil fill plug uppermost, remove the oil fill plug. The oil level should be 5/8" from the top of the pump cover. Follow instructions provided in step 1.
4. Reinstall fill plug and torque to 114 to 120 in-lbs [13 to 14 Nm].
5. If actuator has been repositioned, return unit to normal orientation.
6. Operate actuator (complete system) through five cycles to verify proper operation.

*Continued on page 6 of 6.*



[mm]  
— INCHES —

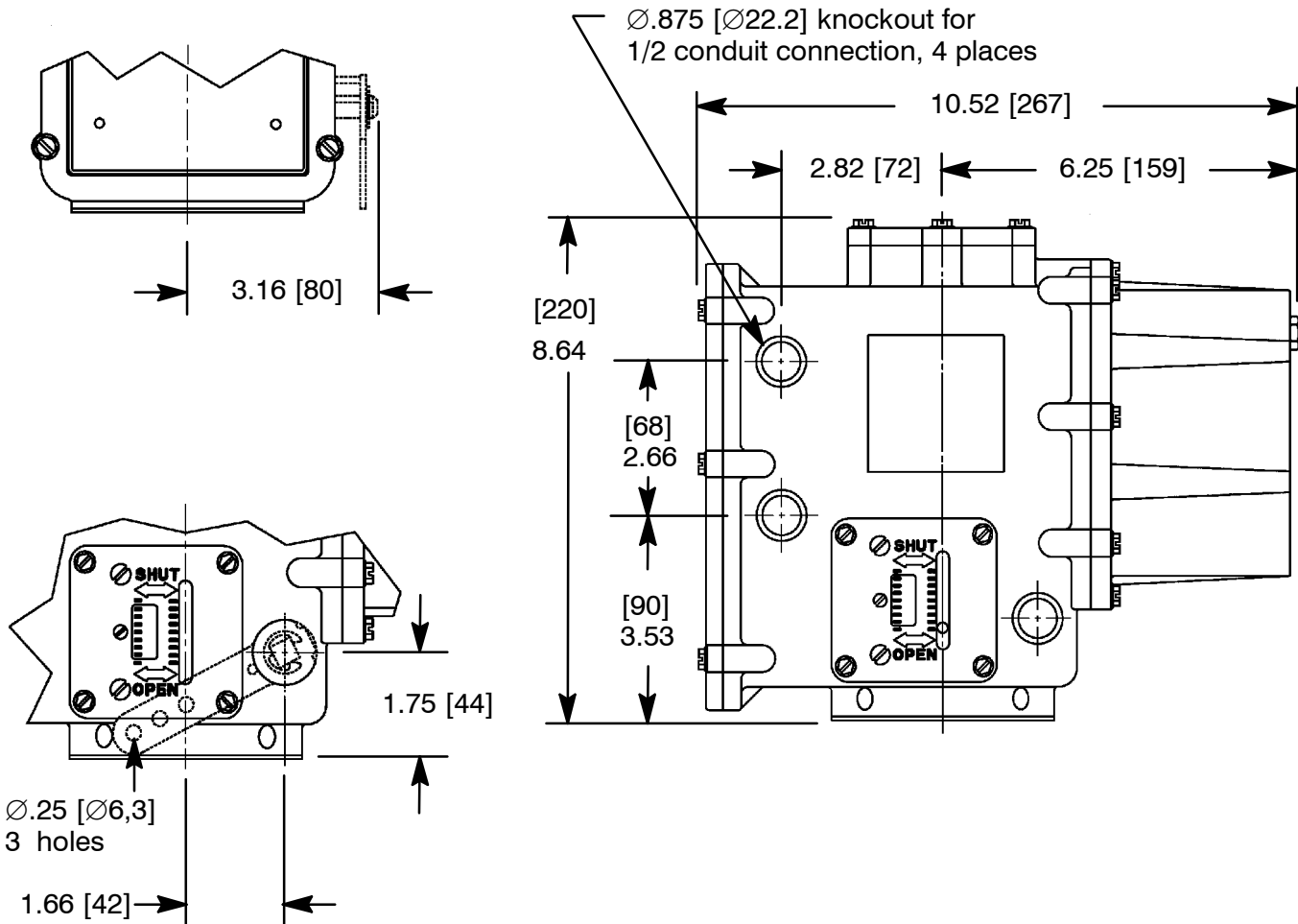

Figure 8. Dimensions