

SAFETY INSTRUCTIONS

⚠ WARNING

1. 120 Volts may cause serious injury from electric shock. Disconnect electrical power before starting installation or servicing. Leave power disconnected until installation/service is completed.
2. Sharp edges may cause serious injury from cuts. Use care when cutting plenum openings and handling duct work.

⚠ CAUTION

1. Read all instructions before beginning installation.
2. Improper installation may cause property damage or injury. Installation, service, and maintenance must be performed by a qualified service technician.

TABLE OF CONTENTS

Safety Instructions	1	Wiring	5
Introduction and Compliance Statement	2	Set Up	6
Specifications	2	Test	6
Install Electrical Outlet	2	Determine Ventilation Time Setting	6
Ventilator Location and Orientation	3	Start Up and Sequence of Operation	7
Mount the Ventilator	3	Troubleshooting	8
Mount Intake Hood	4	Limited Warranty	8
Install Ductwork	4		

READ AND SAVE THESE INSTRUCTIONS

INTRODUCTION AND COMPLIANCE STATEMENT

The Model 8140NF Power Ventilator is designed to bring in precisely the right amount of outdoor air into today's efficiently designed homes. Duct the inlet of the ventilator to an outdoor air intake and duct the discharge to the HVAC system and then simply plug the unit in, set the amount of needed ventilation and select the desired temperature limits.

High/low temperature limits are set on the control to prevent bringing in outdoor air during the hottest or coldest period of the day. The built in control will automatically compensate for the ventilation time that is missed by bringing in additional outdoor air. Compliance with the requirements of ASHRAE 62.2-2010 is met as the control adds ventilation time as needed to account for the fractional on-time and effectiveness of the ventilation schedule. The control will also ensure that ventilation occurs no less than one hour of every four. When properly installed and set, the Model 8140NF Power Ventilator will meet the mechanical ventilation requirements of:

- Energy Star Certified Homes, Version 3
- EPA Indoor airPLUS, Version 1
- 2012 International Residential Code (IRC)
- 2012 International Energy Conservation Code (IECC)

SPECIFICATIONS

TABLE 1 – Specifications

External Static Pressure* ("w.c.)	Airflow (CFM)	Current (amps)	Power (watts)	Efficacy (CFM/watt)
0.0	240	.60	67	3.6
0.2	205	.60	67	3.1
0.4	170	.60	67	2.5
0.6	130	.59	66	2.0
0.8	95	.58	64	1.1
1.0	65	.56	62	1.1

*Measured across ventilator.

Temperature Range: 0°F – 160°F.

Voltage: 115 VAC, 1 phase, 60 Hz.

FIGURE 1 – Overall Dimensions (inches)

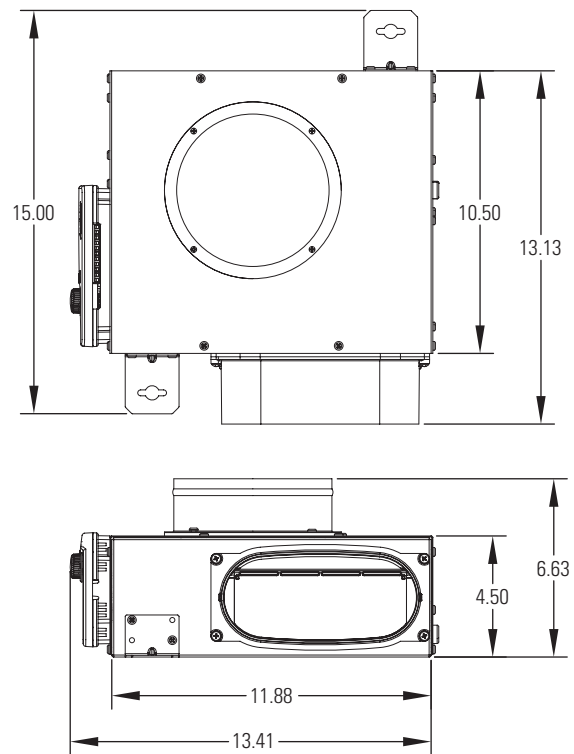

90-2003

INSTALL ELECTRICAL OUTLET

Install a standard NEMA 5-15 switched receptacle suitable for the location, near where the ventilator will be installed. The ventilator comes equipped with a 6-foot power cord with a standard 5-15P plug. Locate the switch in a suitable location to allow the user to manually override the mechanical ventilation system. Use label provided to label the switch "Mechanical Ventilation" or something similar to differentiate it from standard outlet or light switches.

VENTILATOR LOCATION AND ORIENTATION

Choose a location for the ventilator that is within 6 feet of the outlet into which the ventilator will be plugged. The ventilator must be installed with the round inlet duct collar facing up or down, or the oval outlet collar must face up. **DO NOT** install with the outlet collar positioned as shown in **Figure 2E** or **2F**, or the integral backdraft damper will not function properly.

FIGURE 2 – Ventilator Location and Orientation

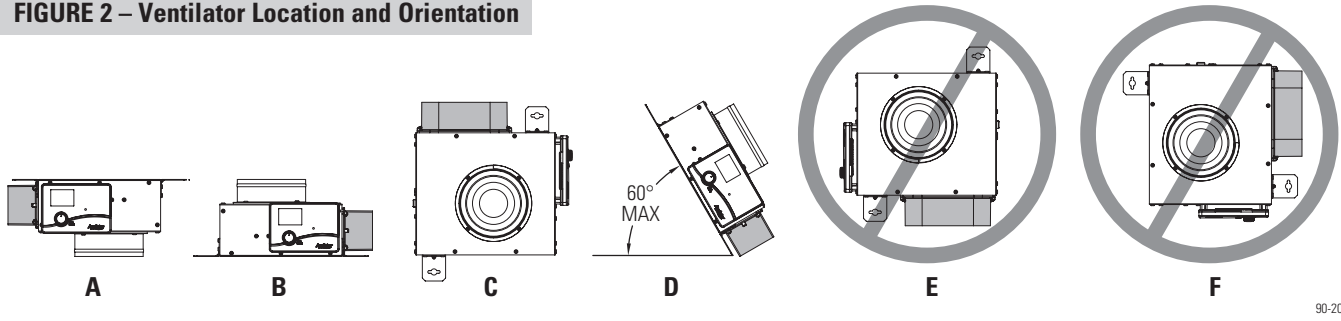

After deciding which orientation the ventilator will be installed, make sure the pivot of the backdraft damper is located above the centerline of the collar. Remove the outlet collar and rotate it 180° if needed to make sure the backdraft damper functions properly.

The control can also be rotated 180° to ensure the display reads in the correct orientation. To rotate the control:

1. Remove the dial on the front of the control.
2. Remove the control housing cover.
3. Remove the two screws securing the control to the ventilator.
4. Rotate the control and seal 180° and align the sensor of the control with the appropriate hole in the housing.
5. Make sure the temperature sensor remains in the housing.
6. Reinstall the control on the housing.

FIGURE 3 – Outlet Collar Orientation

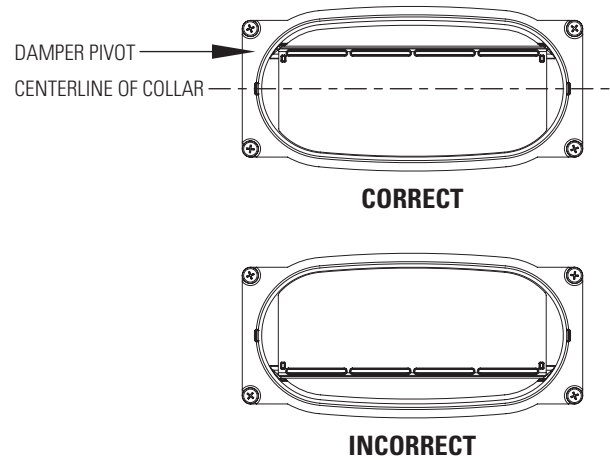

MOUNT THE VENTILATOR

1. Position the mounting brackets as shown and install using the #8 x 1/2" sheet metal screws supplied with the brackets.
2. Locate the ventilator on a joist or platform and screw it into place using the #10 x 3/4" screws provided. See **Figure 4**.
3. Make sure the backdraft damper in the oval outlet collar is positioned so that it will open when the ventilator is on and will close on its own when the ventilator is off. If necessary, remove the collar, rotate it 180° and reinstall.

FIGURE 4 – Mounting Bracket Dimensions (inches)

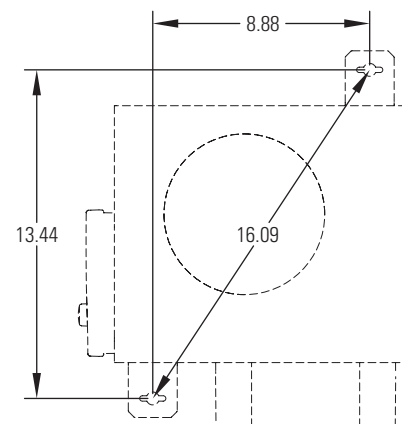

MOUNT INTAKE HOOD

Install a weather tight hood with a bird screen.

Cut a hole in the exterior wall that is large enough to fit 6" insulated flexible duct through with minimal compression of the insulation. Pull the duct through the hole and attach the flex duct to the collar of the hood. Use good quality duct tape or a plastic zip-tie to secure the duct to the collar. Pull the insulation and vapor barrier over the duct and tape it to the collar.

IMPORTANT: The end of the insulation must be sealed to prevent condensation from forming inside the insulation. If a plastic zip-tie is used to secure the insulation to the hood collar, also tape the end to seal it against condensation problems.

Press the hood against the outside wall and secure in place with screws; seal around the perimeter of the hood with caulk.

INSTALL DUCTWORK

Install 6" diameter flexible, insulated duct from the round inlet collar of the unit to the intake hood and from the oval outlet collar of the unit to the supply or return side of the HVAC system.

If the fresh air is being discharged into the return side:

- A Model 6506 powered, normally closed damper must be installed in the inlet duct.
- Remove the backdraft damper from the oval outlet collar. Simply flex the damper in the middle to disengage it from the pivot pins on the collar and remove.

FIGURE 5 – Typical Attic Installation – Power Ventilator Ducted to Supply Duct

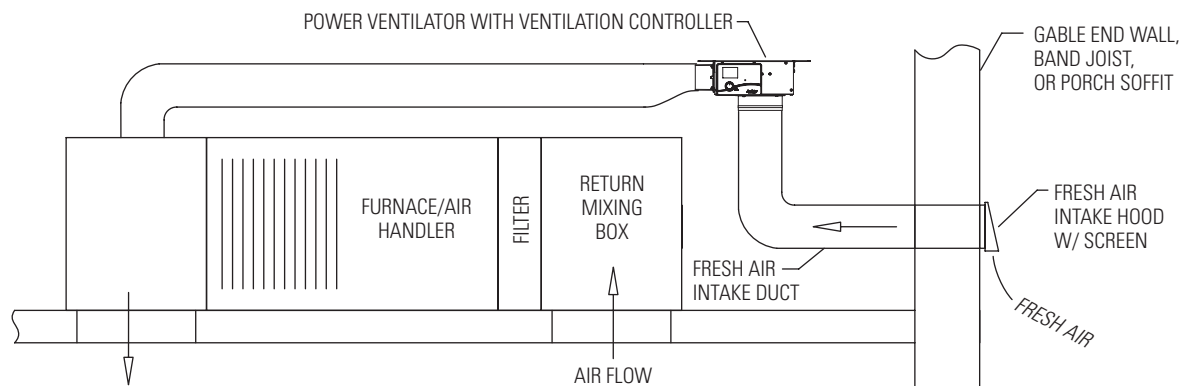

90-2000

FIGURE 6 – Typical Attic Installation – Power Ventilator Ducted to Return Duct

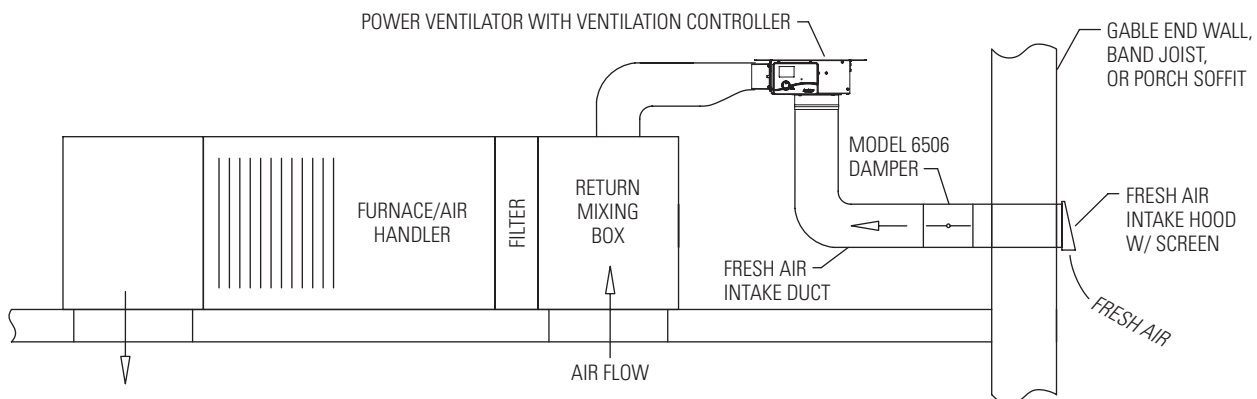

90-2000

WIRING

The ventilator will turn on when the HVAC equipment is running to distribute the fresh air to the home. When ventilation is needed but the HVAC system is not running, the ventilator can turn on the HVAC system blower.

Run a 5-wire thermostat cable from the ventilator to the HVAC system control. Disconnect power to the HVAC system prior to wiring to the HVAC system controls. Select the wiring diagram below appropriate for your application (**Figures 7-9**) – leave pre-installed wires in the ventilation control (yellow and black wires) unless instructed otherwise.

FIGURE 7 – Preferred – Ventilator turns on HVAC system blower as needed

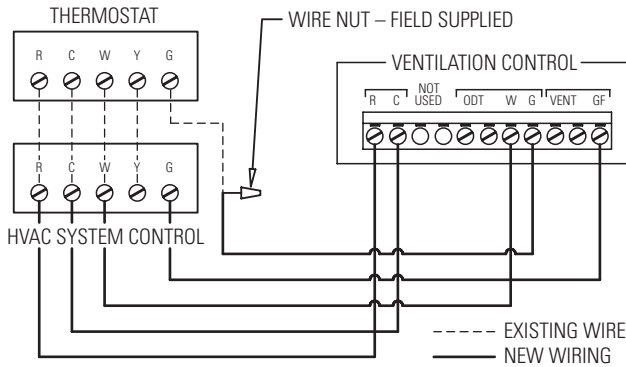

DO NOT remove the pre-installed yellow or black wires when wiring to the HVAC system.

90-2001

FIGURE 8 – Alternate – Ventilator does not turn on the HVAC system blower

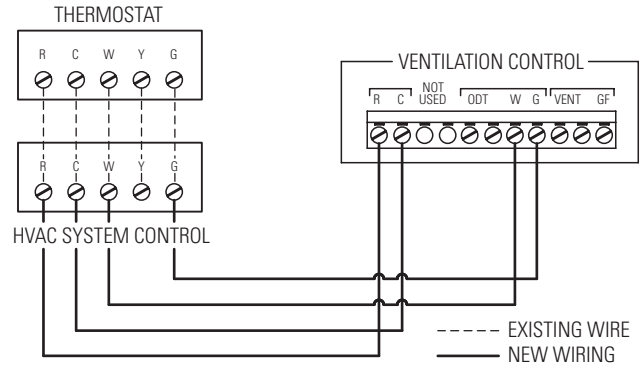

DO NOT remove the pre-installed yellow or black wires when wiring to the HVAC system.

90-2001

FIGURE 9 – Optional wiring to damper if discharging fresh air to return side of HVAC system

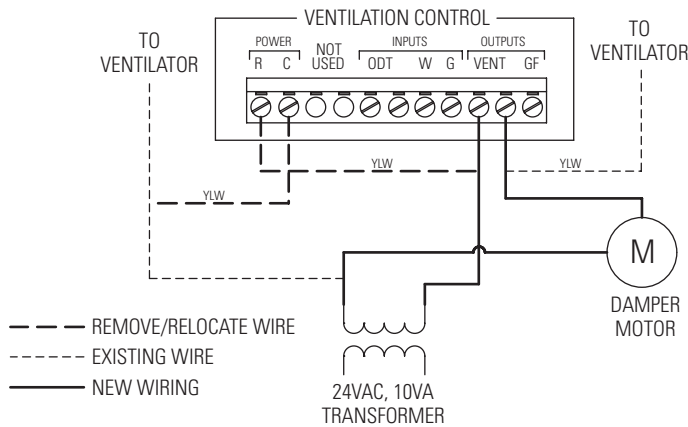

1. Install a 24VAC, 10VA (minimum) transformer and wire the primary side to line voltage.
2. Remove the pre-installed yellow jumper wire between the R and VENT terminals.
3. Disconnect the pre-installed yellow wire from the Ventilation Control C terminal and wire it to the transformer as shown.
4. Wire the damper motor to the transformer and VENT terminal as shown.

90-2001

SET UP

The control can be set up to prevent ventilation during the hottest or coldest periods of the day. When the outdoor temperature exceeds the high value or falls below the low value, ventilation will stop and additional ventilation will be brought in at a later time – See **Start Up** and **Sequence of Operation** for details.

1. Remove the knob then remove the cover to adjust the high/low temperature limit.
2. Use a small flat head screwdriver to turn the potentiometer to select:
 - A – No limit, time only
 - B – 105°F high limit, 20°F low limit
 - C – 100°F high limit, 30°F low limit
 - D – 95°F high limit, 40°F low limit

FIGURE 10 – Setting Temperature Limits

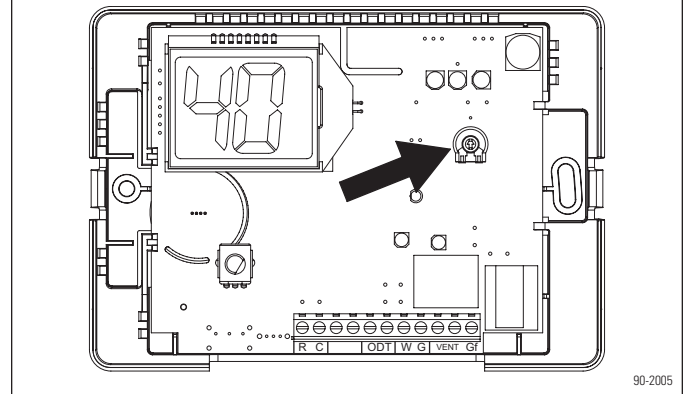

TEST

After all ducting and wiring is complete, plug in the ventilator, restore power to the HVAC system and make sure the switch controlling the outlet into which the ventilator is plugged is turned on. Turn the thermostat to the OFF mode to ensure that wiring the HVAC system has been done correctly. Rotate the Vent Time setting knob to Test/Reset:

1. The display will show “- -”, the green “Active Ventilation” led will blink.
2. The ventilator blower will start.
3. If the ventilator was properly wired to turn on the HVAC unit blower with ventilation, the HVAC blower will turn on.
4. If a separate damper was wired to the inlet duct (ventilation air discharges to the return side of the HVAC system), the damper will open.
5. After one minute the test will end and the display will blink and show the firmware revision level. Return the knob to the OFF position until the desired Time Setting is determined.

DETERMINE VENTILATION TIME SETTING

CALCULATING AIRFLOW REQUIREMENT

1. The MINIMUM ventilation requirement is calculated using ASHRAE 62.2-2010.

$$\text{ASHRAE Airflow in CFM} = [\text{House Area in Sq. Ft.} \times 0.01] + [(\text{Number of Bedrooms} + 1) \times 7.5]$$

NOTE: Use ‘Number of Bedrooms + 1’ or ‘Number of Occupants’, whichever is larger.

2. **Table 2** shows the calculated airflow values to the nearest 5 CFM.
3. Record the required CFM. _____

TABLE 2 – CFM Required

House Sq. Ft.	Number of Bedrooms					
	2	3	4	5	6	7
1000	35	40	50	55	65	70
1500	40	45	55	60	70	75
2000	45	50	60	65	75	80
2500	50	55	65	70	80	85
3000	55	60	70	75	85	90
3500	60	65	75	80	90	95
4000	65	70	80	85	95	100
4500	70	75	85	90	100	105
5000	75	80	90	95	105	110

MEASURE VENTILATION AIR (CFM) DELIVERY RATE AND SELECT VENT TIME

1. Measure the outdoor air flow (CFM) through the duct that is bringing in only outdoor air.
2. Use the CFM Delivered along with the CFM required to find the Cycle Time per hour setting from **Table 3**. For example if the ventilator is providing 120 CFM, and the requirement is 70 CFM, set the time to 35 minutes.

TABLE 3 – Cycle Time Setting (minutes) for Airflow Delivered vs. Airflow Required for 1 hour Cycle

CFM Delivered	CFM Required								
	20	30	40	50	60	70	80	90	100
60	20	30	40	50	60	70	80	90	100
80	15	25	30	40	45	55	60	70	75
100	15	20	25	30	35	40	50	55	60
120	10	15	20	25	30	35	40	45	50
140	10	15	15	20	25	30	35	40	45
160	10	10	15	20	25	25	30	35	40

START UP AND SEQUENCE OF OPERATION

Set the Ventilation Time knob to the setting that was determined in the previous section. The ventilator will turn on with the HVAC equipment for the set number of minutes during the one-hour cycle period. If the HVAC equipment does not turn on enough, the ventilator will turn on, and will turn on the HVAC system blower if wired to do so, at the end of the one-hour cycle period to ensure the desired ventilation time is met. The first time it turns on, it will stay on for five minutes to get an accurate air temperature measurement. If the air temperature is within the range that is set (see **Set Up**), the ventilator will turn on for the amount of time selected within the one-hour cycle period.

If the air temperature is outside of the set range, then no additional ventilation will occur for another hour, and the cycle period will automatically adjust to four hours. When the ventilator starts again, it will sample the air temperature and if in range, will meet the set amount of ventilation during the four-hour cycle period. For example, if the Vent Time was set to 25 minutes per hour and the first time the ventilator came on it measured an air temperature above the high limit setting, it would turn off after five minutes. The control will automatically change the cycle period to four hours and work to provide the additional 95 total minutes of ventilation (25 min/hr * 4 hours = 100 minutes, minus the five minutes of the first air sampling) during the four-hour cycle period.

If the air temperature is still out of range, the control will automatically switch to an 8-hour cycle period, then a 12-hour cycle period and finally a 24-hour cycle period. During 8, 12 and 24 hour cycle periods, the total ventilation time increases to compensate for ventilation effectiveness as defined in ASHRAE Standard 62.2-2010. When the cycle period automatically adjusts to 24-hours, the control will turn on ventilation to meet the requirements even if the temperature is outside of the set limits.

TROUBLESHOOTING

TABLE 4 – Troubleshooting Guide

Symptom	Possible Reason	Correction
Ventilator and display on control does not turn on.	No power to the control.	<ul style="list-style-type: none"> • Wire the control to the HVAC system as shown in the wiring diagrams on page 5. • Turn on power to the HVAC system.
Ventilator does not turn on, but display on control is on.	No power to the outlet into which the ventilator is plugged.	<ul style="list-style-type: none"> • Turn on switch that controls outlet.
E3 shows on display.	Temperature sensor is damaged or not wired to the control ODT terminals.	<ul style="list-style-type: none"> • Make sure both black wires of the sensor are connected to the ODT terminals. • If connected, disconnect and measure the resistance across the black wires. If it is open or shorted, replace sensor.
Air is blowing out of the intake hood.	Backdraft damper is open.	<ul style="list-style-type: none"> • Make sure the unit is mounted in the proper orientation – outlet cannot point down. • Remove the oval outlet collar and rotate it 180° so that it closes when the ventilator turns off.
"r#" (where # is a number) shows on the display.	Left in test mode.	<ul style="list-style-type: none"> • Turn knob to time setting.

LIMITED WARRANTY

Your Research Products Corporation Aprilaire® Ventilator is expressly warranted for five (5) years from date of installation to be free from defects in materials or workmanship.

Research Products Corporation's exclusive obligation under this warranty shall be to supply, without charge, a replacement for any component which is found to be defective within such five (5) year period and which is returned not later than thirty (30) days after said five (5) year period by you to either your original supplier or to Research Products Corporation, Madison, Wisconsin 53701, together with the model number and installation date of the dehumidifier.

THIS WARRANTY SHALL NOT OBLIGATE RESEARCH PRODUCTS CORPORATION FOR ANY LABOR COSTS AND SHALL NOT APPLY TO DEFECTS IN WORKMANSHIP OR MATERIALS FURNISHED BY YOU INSTALLER AS CONTRASTED TO DEFECTS IN THE VENTILATOR ITSELF.

IMPLIED WARRANTIES OF MERCHANTABILITY OR FITNESS FOR A PARTICULAR PURPOSE SHALL BE LIMITED IN DURATION TO THE AFORESAID FIVE YEAR PERIOD. RESEARCH PRODUCTS CORPORATION'S LIABILITY FOR INCIDENTAL OR CONSEQUENTIAL DAMAGES, OTHER THAN DAMAGES FOR PERSONAL INJURIES, RESULTING FROM ANY BREACH OF THE AFORESAID IMPLIED WARRANTIES OR THE ABOVE LIMITED WARRANTY IS EXPRESSLY EXCLUDED. THIS LIMITED WARRANTY IS VOID IF DEFECTS(S) RESULT FROM FAILURE TO HAVE THIS UNIT INSTALLED BY A QUALIFIED HEATING AND AIR CONDITIONING CONTRACTOR. IF THE LIMITED WARRANTY IS VOID DUE TO FAILURE TO USE A QUALIFIED CONTRACTOR, ALL DISCLAIMERS OF IMPLIED WARRANTIES SHALL BE EFFECTIVE UPON INSTALLATION.

Some states do not allow limitations on how long an implied warranty lasts or the exclusion or limitation of incidental or consequential damages so the above exclusion or limitations may not apply to you.

This warranty gives you specific legal rights and you may also have other rights which vary from state to state.

WARRANTY REGISTRATION

Visit us on-line at www.aprilaire.com to register your Aprilaire product. If you do not have on-line access, please mail a postcard with your name, address, phone number, email address, product purchased, model number, date of purchase and dealer name and address to:

Research Products Corporation, P.O. Box 1467, Madison, WI 53701

Your Warranty Registration information will not be sold or shared outside of this company.

Aprilaire®

P.O. Box 1467 • Madison, WI 53701-1467 • Phone: 800/334-6011 • Fax: 608/257-4357 • www.aprilairepartners.com