

Rentals/Temporary and Permanent Installation Tips:

By using a 1 1/2" spigot trap adapter and no-hub coupling, the ET117-006 may be removed and the standpipe left in its original condition. You can unscrew the ET117-006 to check flow rates, or install at a new location even if a trap adapter or wye and trap adapter combination is permanently glued to the standpipe.

The two trap adapters provided with your ET117-006 will allow you to make a connection to any standpipe configuration encountered: use the close 1 1/2" MIPT nipple in a threaded female fitting, the spigot adapter in a female slip fitting, and a hub adapter over PVC pipe. The Beveled washer and O-ring are interchangeable, but should not be used together.

No-Hub connectors:

Ideal for cast iron or non-threaded galvanized steel, copper, and ABS/PVC Pipe. With the use of non-hub couplings, it is a simple procedure to splice into any drain line to fabricate a standpipe.

Note:

In most residential applications, it is permissible to transition from metal to plastic using no-hub couplings, however some commercial buildings require a uniformity of materials throughout the drainage system such as all no-hub cast iron pipe. For this reason, it is advisable to determine the specific code requirements for each job.

List of materials useful to have on hand:

(These materials are inexpensive, easy to find, and take up very little space.)

2" No-Hub Coupling	2" ABS/PVC Combination Tee
2" x 1 1/2" No-Hub Coupling	2" x 1 1/2" ABS/PVC Combination Tee
1 1/2" No-Hub Coupling	1 1/2" ABS/PVC Combination Tee
2" ABS/PVC Wye (Hub or Street)	2" ABS/PVC Sanitary Tee
2" x 1 1/2" ABS/PVC Wye (Hub or Street)	2" x 1 1/2" ABS/PVC Sanitary Tee
1 1/2" ABS/PVC Wye (Hub or Street)	1 1/2" ABS/PVC Sanitary Tee
2" ABS/PVC P-Trap	2" ABS/PVC Sch-40 Pipe (5'-10')
1 1/2" ABS/PVC P-Trap	1 1/2" ABS/PVC Sch-40 Pipe (5'-10')
2" x 1 1/2" ABS/PVC Reducer Coupling	ABS Glue
2" x 1 1/2" ABS/PVC Flush Brushing	PVC Primer & Glue
1 1/2" ABS/PVC Street 45 (1/8 Bend)	1" Teflon Tape or Pipe Joint Compound

Tools useful to have on hand:

- Sawzall Pipe/Tube Cutter or Hacksaw
- Channel Lock or Pipe Wrench
- No-Hub Wrench or Straight Screw Driver
- Tape Measure

Serving the
Water Treatment
& Plumbing Industry



MADE IN USA
ASME A112.1.3



Copyright AIR GAP INTERNATIONAL



Placentia, California



Model:

ET117-006 (DLA-GTM)

**5/8-INCH INLET
1-1/2-INCH OUTLET
AIR GAP**

Pat. No. 5,449,456
Pat. No. 5,681,459
Pat. No. 5,944,985
Pat. No. 6,193,879

MADE IN USA

► For Schedule – 40
Standpipe Installation



ASME A112.1.3

Old Part Number:

G-58JP

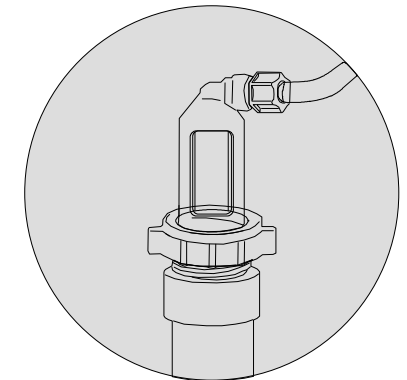

ET117-006

Installation Procedures

For Stand Pipe Applications

LIST OF PARTS ENCLOSED

- 1 – Drain Line Adapter Airgap with 5/8" Compression Connection
- 1 – 1 1/2" Schedule – 40 (Hub x Male Pipe Thread) PVC Trap Adapter
- 1 – 1 1/2" Schedule – 40 (Spigot x Male Pipe Thread) PVC Trap Adapter
- 1 – 1 1/2" Slip Joint (S.J.) Wing Nut
- 1 – 1 1/2" Slip Joint (S.J.) Beveled Washer
- 1 – 1 1/2" Nitrile O-Ring (for alternate use instead of washer)
- 1 – 5/8" Jaco Compression Nut

• The ET117-006 provides a true air gap for all Schedule-40 DWV standpipes.
 • These instructions are intended for a professional installer. Examples are provided without giving details of every procedure.

To comply with all plumbing code requirements, the standpipe used with an ET117 series must be trapped, vented and fabricated from a Schedule-40 Drain Waste and Vent that has been approved in your area, such as: ABS, PVC, galvanized steel, copper, or no-hub cast iron with an inside diameter of 1-1/2-inch or greater.

Below are the three practical standpipe configurations:

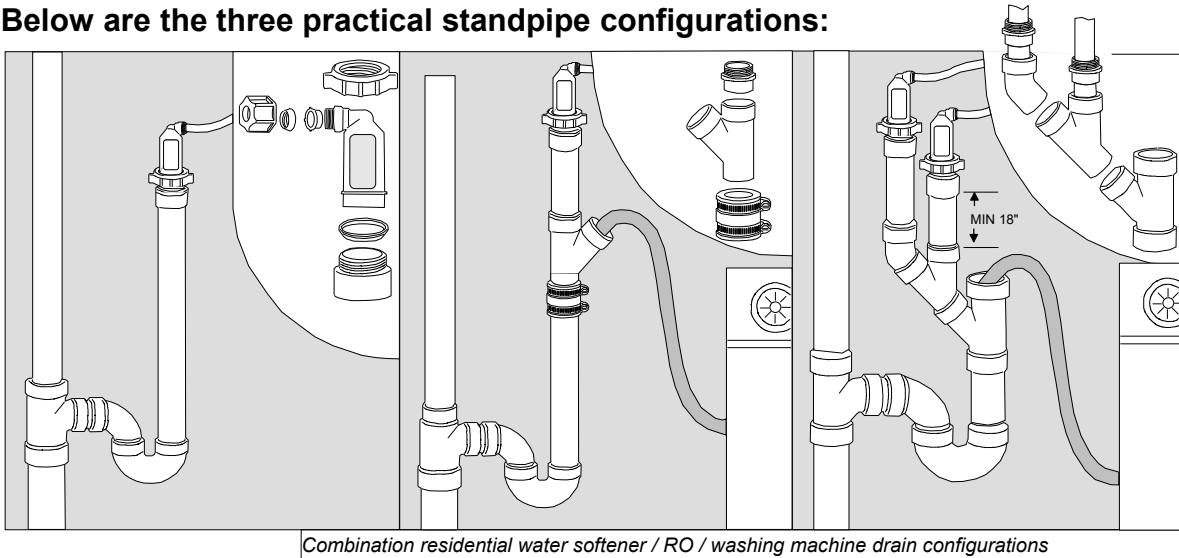

5/8" Jaco Compression Nut Installation Instruction:

1. Cut the tubing end squarely and remove the internal and external burrs.
2. Insert the tubing through the back of the nut all the way through the nut assembly to the tube stop in the fitting body.
3. While holding the tubing firmly against the tube stop, hand tighten the nut.
4. Wrench tighten the nut 1 1/2 to 2 additional turns.
5. All nuts must be retightened when the system reaches projected operating temperature.

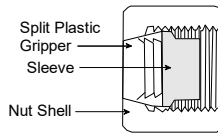
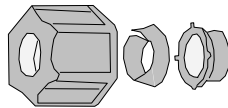

Compression Nut Assy

Tube installation instruction:

1. Tubing must be cut straight using a tubing cutter; not a knife. If the cut is at an angle, the O-ring may not seal properly.



2. Tubing must be inserted all the way into the air gap, one full inch. It may be necessary to rotate the airgap back and forth while pushing on the tube.

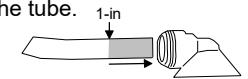

The examples below:

illustrate how the ET117 Series may be adapted to different pipe materials and size encountered in the field:

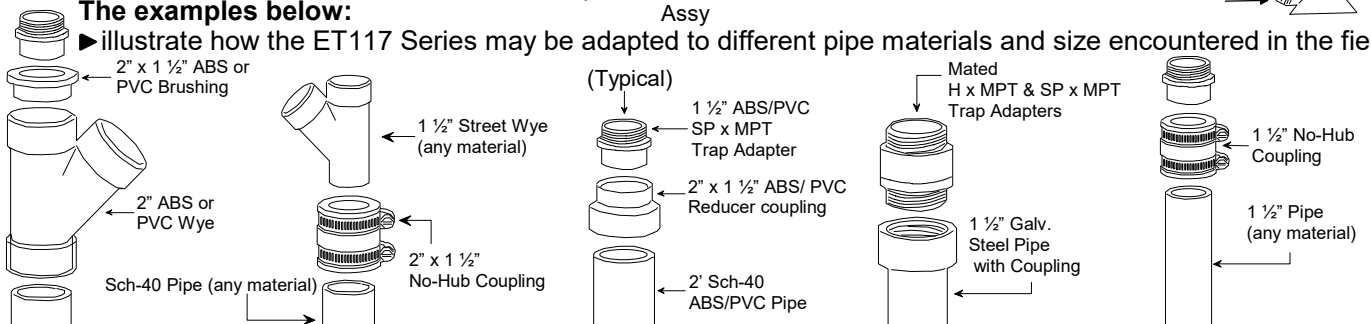

-OVER-