

CONFIGURATION – B

Installation (without Dishwasher)

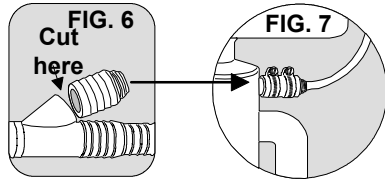
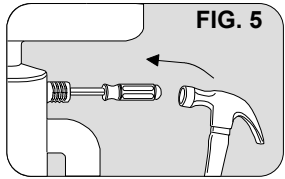

1. Knock out the plug inside the disposal nipple by using a hammer and flat screwdriver. Tap away all edges of the “knock out” plug until only a round hole remains. (See Fig.5)
2. Remove all pieces of plug left inside the disposal after ensuring that the power has been disconnected. Run fingers carefully around bottom circumference of chamber to search for any hidden fragments. (See Caution below)
3. Cut off the “wye branch” of the ET116-001 with a hacksaw. Use the grooved “cut line” provided, then smooth away any burrs. (See Fig.6)
4. Follow instructions 5, 6, & 10 of Configuration – A to complete the installation. (Only the “cut branch” will be used in instruction 6, discarding the leftover section of adapter. See Fig. 7)
5. After reconnecting the power supply, test to see that disposal is clear. Quickly turn switch on then off and listen for sound of any fragments. If an obstruction is heard, disconnect power and repeat instruction 2 above until disposal is clear.

CAUTION:

The installer is urged to exercise extreme caution whenever reaching inside the disposal. After confirming that power has absolutely been turned off (and will stay off until the job is done), use extra care that fingers are not cut on any sharp surfaces. Also, caution should be taken to avoid “over-tightening” screw-type hose clamps.

AVOID SIPHONING RO reject water into dishwasher.

(See important details below)

IMPORTANT:

The ET116-001 is designed to be used downstream of an approved airgap faucet and dishwasher air gap (when installed in conjunction with a dishwasher). Most dishwashers have a built-in check valve, but these often fail. Some states require the installation of a manufactured dishwasher air gap, while other states permit the drain hose to loop up from the dishwasher to the underside of the sink before descending to the disposal (See Fig. 3). Do not install an ET116-001 (with dishwasher) in the absence of one of these types of airgaps – use an ET109-001 or ET112-001.

Serving the
Reverse Osmosis
Water Treatment Industry

MADE IN USA



NOTE:

To connect reverse osmosis reject water drain line to the plumbing of a single or double compartment sink without disposal, please request a ET112-001.

Copyright © AIRGAP INTERNATIONAL a Division of Altinex Inc.



500 S Jefferson Street, Placentia CA 92870 USA • 949-955-3928 • Email: orders@airgap.com



Placentia, California



Model:

ET116-001

REVERSE OSMOSIS DRAIN LINE ADAPTER

Pat. No. 5,635,058

MADE IN USA

► For Disposal Connection with or without Dishwasher

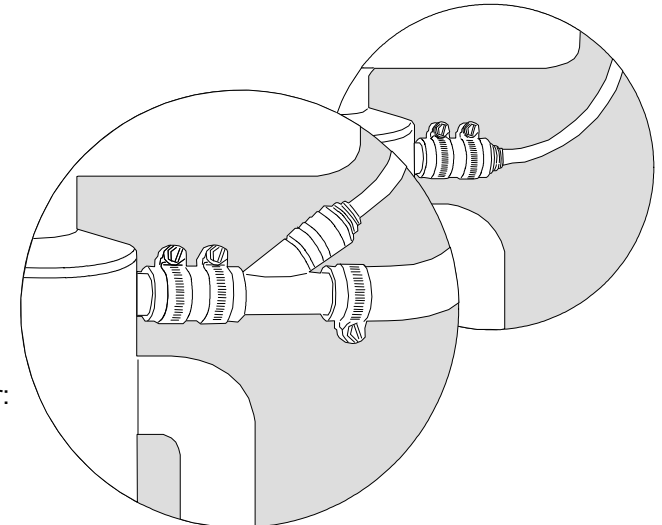

Old Part Number:
D-25QC
DLA-D™

Doc. # 400-0724-007

ET116-001

Installation Procedures

For Disposal Connection with or without Dishwasher

LIST OF PARTS ENCLOSED

1 – Drain Line Adapter with Push-In Connector ET116-001

1 – Hose Coupler

2 – Marine Stainless Steel Hose Clamps

1 – Locking clip for 1/4" tube

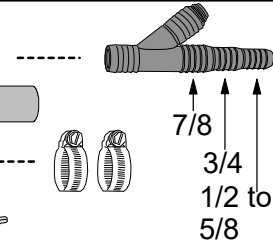

•The ET116-001 provides an IAPMO / UPC listed alternative to the use of the drain saddle which is a prohibited fitting in the United States.

• To install the ET116-001 reverse osmosis reject water Drain Line Adapter, follow these instructions.

CONFIGURATION – A Installation (with Dishwasher)

1. Disconnect the power supply to the disposal by unplugging the cord under the sink, or shutting off the circuit breaker before starting work. (Do this for configuration A & B)

2. Remove dishwasher drain hose from disposal by unscrewing hose clamp, or expanding spring clamp with pliers. Move clamp away from disposal nipple, then twist hose back and forth while pulling away from disposal to separate. (See Fig. 1)

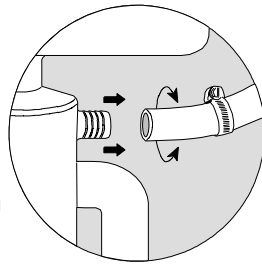

FIG. 1

3. Universal barbs on the ET116-001 will accommodate the various (IDs) inside diameters dishwasher hoses. Determine which size is required by sliding open end of the hose over the stepped barbs until one fits snugly. If the hose fits snugly over the middle or largest barb, you must cut away the smaller barb(s) with a hacksaw. Use the grooved "cut lines" provided, then smooth away any burrs. (See Fig. 2a)

4. Scrape the inside of the exposed disposal nipple with a screwdriver to remove any build-up caused by a dishwasher. (See Fig. 2b)

5. Mount hose coupler (provided) one inch over disposal nipple. Then slip both new stainless steel hose clamps (provided) loosely over hose coupler. (See Fig. 2c)

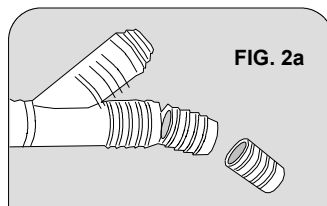

FIG. 2a

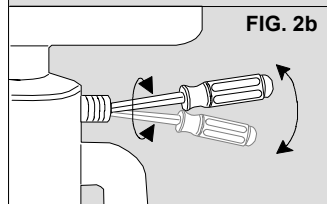

FIG. 2b

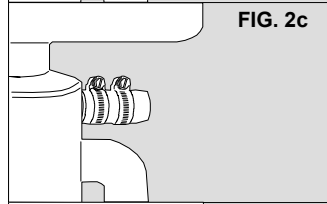

FIG. 2c

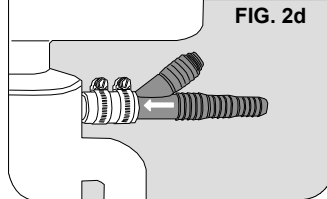

FIG. 2d

6. Point arrows of ET116-001 toward disposal and slide barbs into the remaining one inch of the hose coupler until firmly seated against the disposal nipple. Orient the "wye branch" in a vertical position to receive the RO drain tube. Tighten both hose clamps securely over hose coupler so that the ET116-001 is secure on disposal. (See Fig. 2d)

7. Lift the tail of the adapter slightly higher than horizontal, and position semi-taut hose behind it. Measure the hose against the selected barb. (See Fig. 3)

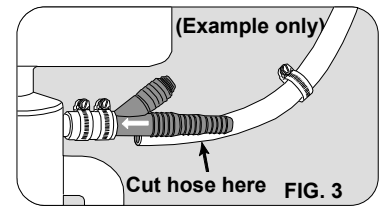

FIG. 3

8. Cut off excess hose squarely with a sharp knife. Reuse original spring or hose type clamp by sliding loosely over the hose. (See Fig. 3)

9. Twist hose over the selected barb, then slide hose clamp down and tighten securely.

(See Large Cover Illustration)
Note: Use tautness of dishwasher hose to keep the tail of the adapter slightly above the horizontal plane; this is important for proper drainage and a clog-free installation. If dishwasher hose material cannot be easily shortened or it is undesirable to do so, attach the uncut end of the hose to the adapter, then tie up the remaining slack with suitable material.

10. Remove locking clip and insert RO 1/4-inch drain tube into Push in connector to complete the installation (See Fig. 4a).

11. Apply locking clip for push in connector fittings. (See Fig. 4b). Clip fits around the connector to prevent leaks or accidental disconnection of the tube, then reconnect the power supply to disposal.

In some instances, the disposal may be oriented away from the air gap faucet. Solution: redirect the ET116-001 using a 3/4-inch copper 45° or 90° elbow between the disposal and ET116-001 as desired (requires an extra hose coupler and two hose clamps).

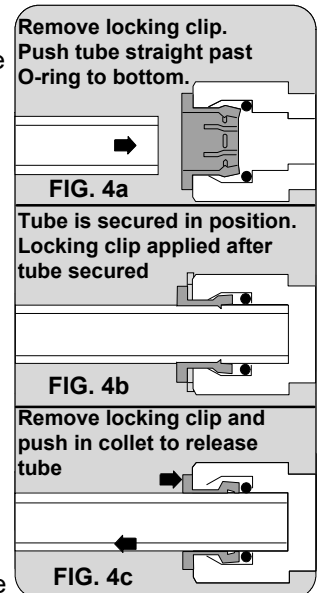

FIG. 4 Quick Connect / Push-in Connector