

**IMPORTANT:**

Remove the garbage disposal knock-out plug if still present. Tap away all edges until a round hole remains. Disconnect power to the garbage disposal unit and then remove all loose pieces from the inside the disposal. Run fingers carefully around the bottom of the disposal chamber to locate any fragments. (See Warning below)

**WARNING:**

Exercise extreme caution whenever reaching hand inside the garbage disposal. After confirming that power has been turned off (and will stay off until the job is complete), use extra care not to cut fingers on sharp surfaces.

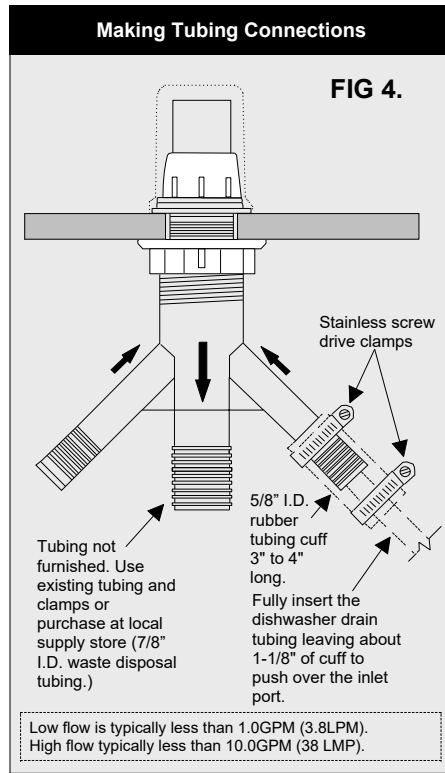

**REPLACEMENT INSTALLATION:**

(To replace an existing dishwasher air gap with the AG200-005)

1. Disconnect inlet and outlet drain hoses from the existing air gap. Save hose clamps for reassembly.
2. Remove the existing air gap from a sink or countertop. Clean the surface before installing the AG200-005.
3. Follow instructions under the new installation section.

**MAINTENANCE:**

Dishwasher air gaps may become clogged with leftover food debris escaping the dishwasher filtering mechanism. The AG200-005 is easy to clean in the event of a clog. To clear a blockage, remove the decorative cover cap and unscrew the top nut. Remove the top housing, sliding it straight up and then remove any trapped food particles. After cleaning, carefully replace the top housing. Take care to align the key on the top housing with A slot in the air gap's body (see Fig.2). Install the top nut before replacing the Cover cap.



Placentia, California



**Model:**  
**AG200-X05**  
**AMERIGAP®**

**DISHWASHER AND RO AIR GAP**  
**(Maximum flow rate 11 GPM)**

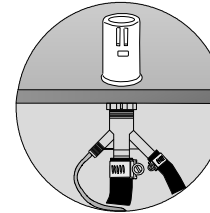

**COMPATIBILITY:**  
AG200-005 is not compatible with reverse osmosis faucets with air gap.

AG200-005	AIRGAP WITH CHROME FINISH PLASTIC CAP
AG200-105	AIRGAP WITH BRUSHED NICKEL FINISH BRASS CAP
AG200-205	AIRGAP WITH POLISHED CHROME FINISH BRASS CAP
AG200-305	AIRGAP WITH OIL RUBBED BRONZE FINISH BRASS CAP
AG200-405	AIRGAP WITH BRUSHED STAINLESS STEEL FINISH BRASS CAP
AG200-505	AIRGAP WITH BLACK MATT FINISH BRASS CAP
AG200-605	AIRGAP WITH POLISHED NICKEL FINISH BRASS CAP
AG200-705	AIRGAP WITH SATIN NICKEL FINISH BRASS CAP
AG200-805	AIRGAP WITH BRUSHED BRONZE FINISH BRASS CAP



Copyright AIR GAP INTERNATIONAL

# AG200-005

## Installation Procedures

**Caution - Do Not Overtighten Nuts or Clamps**

### LIST OF PARTS ENCLOSED

1 – Main Body

1 – Decorative Cap

1 – Bottom Nut

1 – Washer

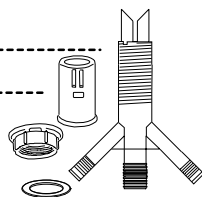

1 – Top Housing

1 – Mounting Nut

1 – Top Nut

1 – Inlet Plug



**A dishwasher and RO air gap is a critical component in maintaining a safe water supply. It prevents contaminated water from re-entering the dishwasher from the drain via backflow and is required by plumbing code in most states.**

**The Amerigap air gaps ensure safety and peace of mind that your water supply is clean.**

Please read the instructions once through before starting.

### NEW INSTALLATION

1. Unit installation requires a 1-3/8-inch hole in the sink or countertop.

2. Unscrew the top nut from the AG200-005 body. Next, unscrew and remove the mounting nut and the washer. Turn the bottom nut further down the air gap's body. Leave sufficient length for the thread to protrude up through the mounting hole. (See Fig.1)

3. Insert the air gap from the bottom through the hole in the sink. Reinstall the washer, mounting nut and top nut over the threaded main body of the unit.

4. If only RO unit needed, use the plug provided to cover the unused dishwasher port.

5. If a port plug is required, then remove the top housing sliding it straight up. After the plug is inserted, place the top housing back by pushing down and carefully rotating it until the housing key engages with the slot keyway in the threaded air gap body. (See Fig. 2).

6. Install top nut over the housing and screw it down until it touches the mounting nut.

7. Orient the bottom inlets and outlet under the sink as desired. Pull down on the air gap while tightening the bottom nut clockwise.

**DO NOT OVER-TIGHTEN.**

8. Install the decorative cap by pushing it down over the housing. Rotate the decorative cap so that the two air gap openings face the sink.

9. Connect the dishwasher drain hose to the 5/8-inch inlet port 2 of the AG200-005 with hose clamp. (See Fig. 3).

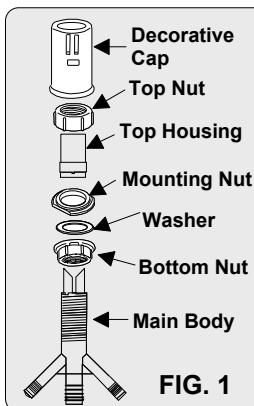

FIG. 1

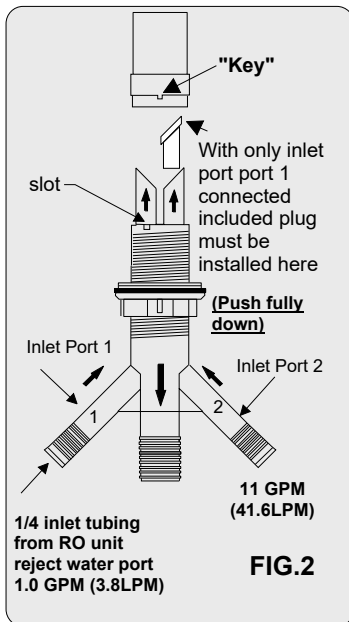

FIG.2

To clean the decorative cap, use mild soap and water. Do not clean with abrasive cleaners.

CAUTION: (NO TOOLS) Use hands only above the sink

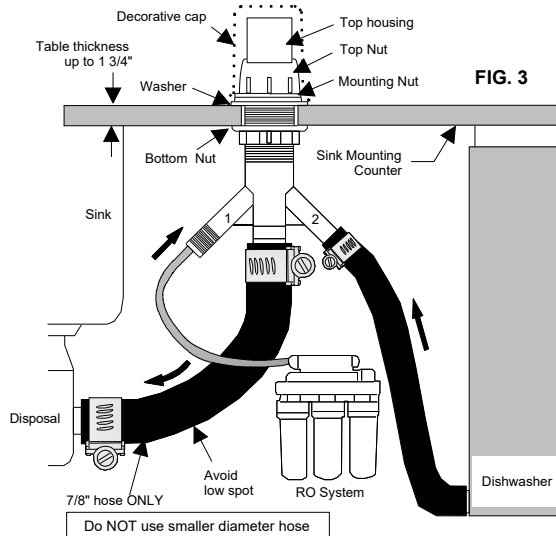
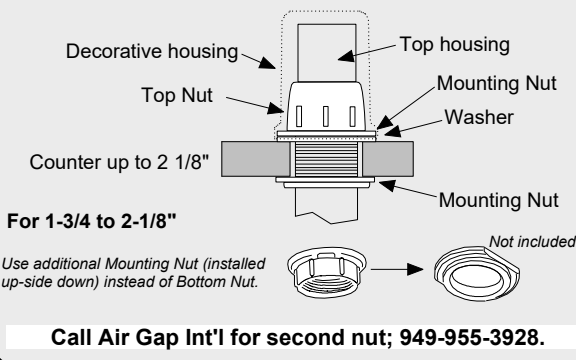

FIG. 3

### Counters 1-3/4" to 2-1/8" Thick



10. Connect 1/4-inch tubing from RO unit into 1/4-inch push-in connector in inlet port 1 of the AG200-005. (See Fig. 3).

11. Connect the AG200-005 outlet to the garbage disposal drain inlet by using 7/8-inch ID waste disposal tubing and two hose clamps. (See Fig. 3).

12. If need to make tubing connection to the dishwasher inlet port 2 of the AG200-005 (See Fig. 4).