

4. Inlet port fits 1/2" schedule 40PVC slip fittings. (see FIG 1-4)  
 Connect inlet port of AG140-001 to the water softener.

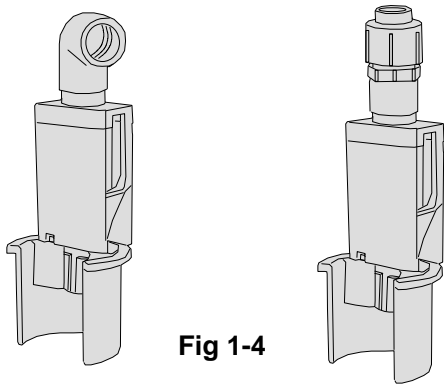
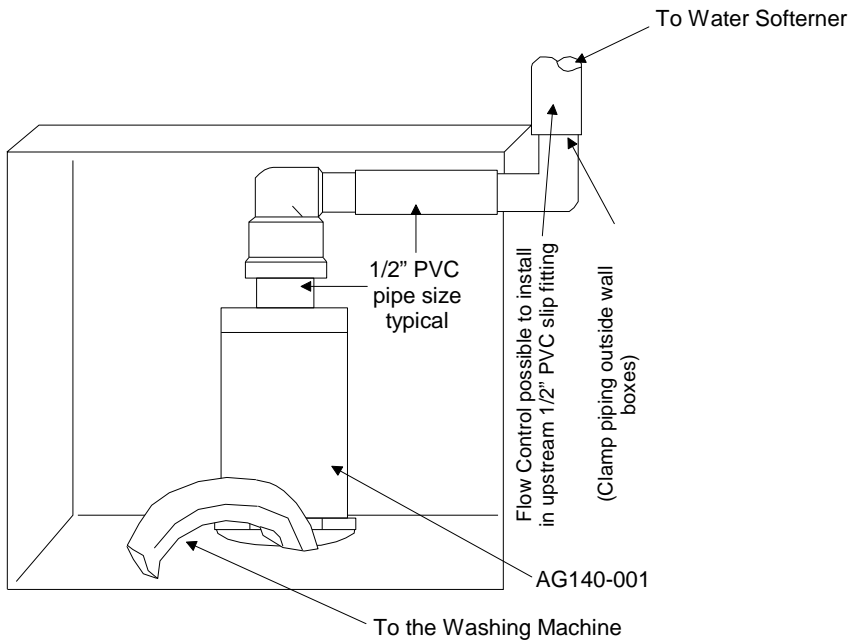

Fig 1-4



One typical Piping Installation



Model:  
**AG140-001**

## 2-INCH STANDPIPE UNIVERSAL 14GPM AIR GAP

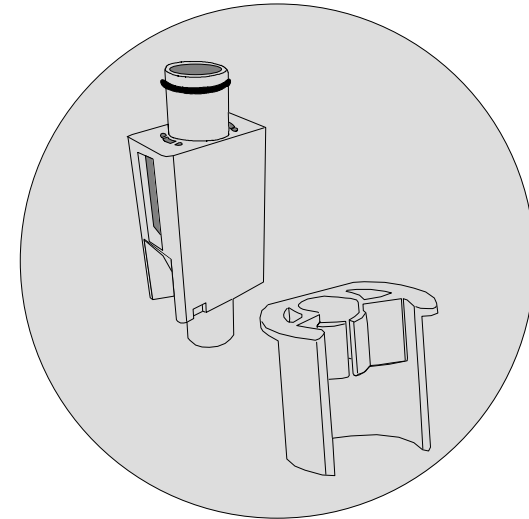

Old Part Number:  
 GAP-IT, 61-S

Doc.#400-0655-005

# AG140-001

## Installation Procedures

### LIST OF PARTS ENCLOSED

1- Water Softener Air Gap

1- Mounting Base for 2" Pipe

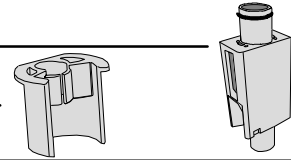

The AG140 -001 is a water softener air gap, designed to share the drainpipe with a washing machine discharge tubing. The AG140-001 feature a flow straightener to quiet and smooth out turbulent flow and splash shields to provide completely dry operation.

- Air gap fits into a recessed washing machine box with 2" drain pipe
- Allow space for washer drain hook or soft rubber washer hose
- Tested at 15 GPM (56.8 Liter/minute)
- Recommended usage 7 GPM (26.7 Liters/minute)
- Inlet port fits 1/2" schedule 40PVC slip fitting with O ring
- UPC® listed and tested for compliance with IPC and NSF standards

Always comply with local plumbing codes during installation

Please read the instructions once through before starting.

### AG140-001 INSTALLATION INSTRUCTION

1. Make sure that the flow rate output of the water softener meets AG140-001 flow capacity limits.
2. Install the water softener air gap into the mounting base, as shown (see FIG 1-1), for dimensions see FIG 1-2.

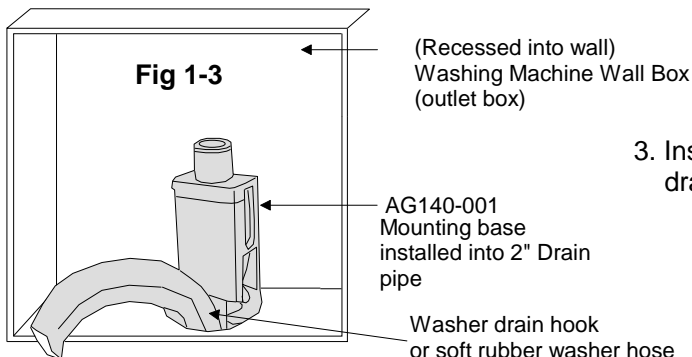
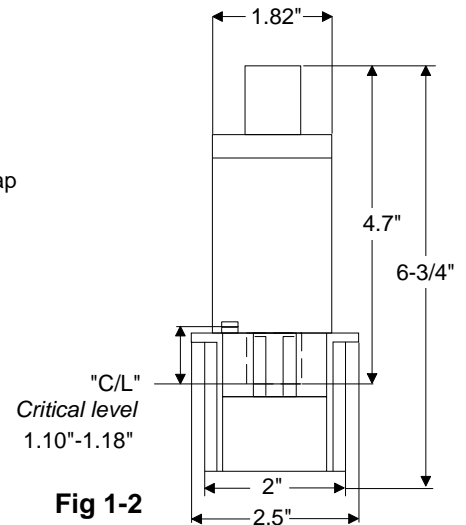
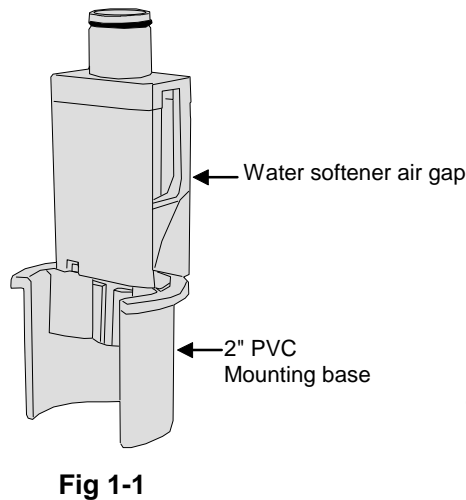
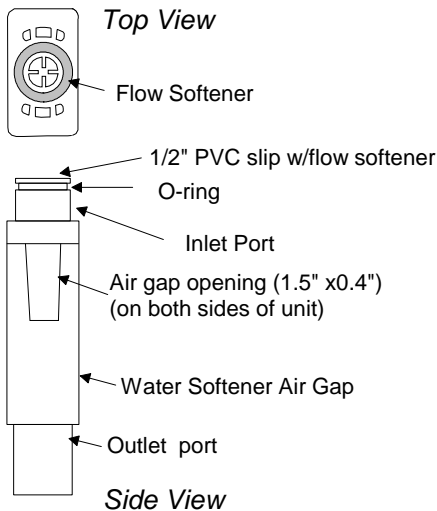

3. Insert water softener air gap in the mounting base, into 2" drain standpipe.(see FIG 1-3).