



High-quality, architecturally pleasing, innovative access doors for walls, ceilings, ducts, floors, and roofs



Self Stick DUCT DOORS for Sheet Metal Duct

HDSS-6020

Application

- Provides easy access to sheet metal ducts

Product Features

- Innovative self stick frame for easy installation
- Insulated door panel, single cam, hinged
- Tested to 10" SP with minimal leakage

Options:

- ALUMINUM
- STAINLESS STEEL
- CYLINDER LOCK & KEY
- HASP + STAPLE
- L HANDLE

HDSS-6020 Duct Access Door Specifications:

Door: 24 gauge galvanized steel, double panel

Frame: 24 gauge galvanized steel

Hinge: Continuous aluminum piano hinge

Insulation: Door panel filled with 1" fiberglass insulation

Gasketing: 1/8" thick by 1/2" wide closed cell neoprene gasketing between door and frame. 1/8" thick by 1 1/2" wide adhesive bonded gasket between frame to duct

Latch: Self tightening, hand operated cam latches

Hardware: Hex head sheet metal screws

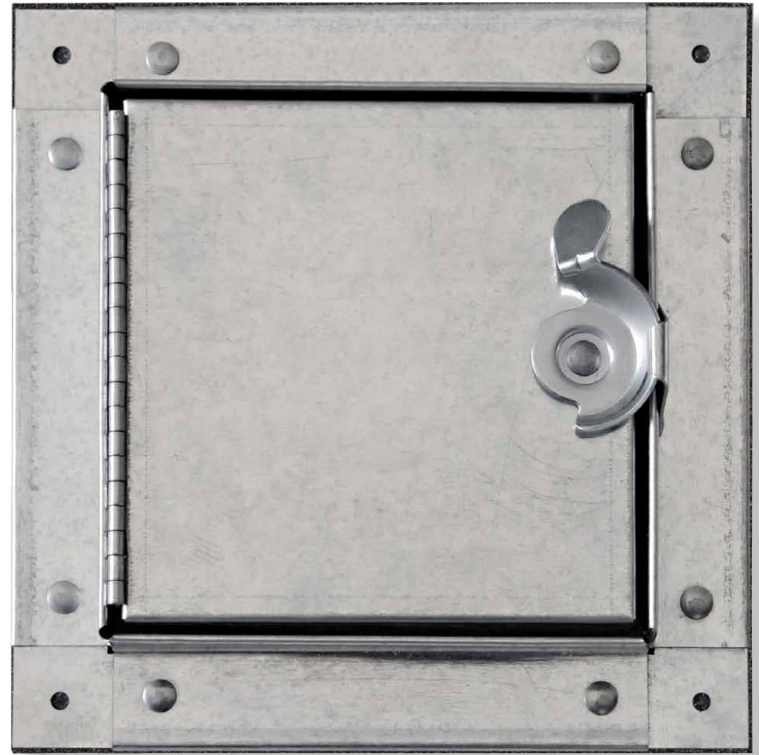

STANDARD SIZES (Special sizes available upon request)

NOMINAL DOOR SIZE W x H		WEIGHT PER DOOR			
inches	mm	Duct Opening	latches	lbs.	kg.
6 x 6	150 x 150	4 1/2 x 4 1/2	1	1.25	0.6
8 x 8	200 x 200	6 1/2 x 6 1/2	1	1.75	0.8
10 x 10	250 x 250	8 1/2 x 8 1/2	1	2.75	1.3
12 x 12	300 x 300	10 1/2 x 10 1/2	1	3.75	1.7
12 x 18	300 x 450	10 1/2 x 10 1/2	2	3.5	1.6
14 x 14	350 x 350	12 1/2 x 12 1/2	2	4.75	2.2
16 x 16	400 x 400	14 1/2 x 14 1/2	2	5.25	2.4
18 x 18	450 x 450	16 1/2 x 16 1/2	2	6.75	3.1
20 x 20	500 x 500	18 1/2 x 18 1/2	2	9	4.1
24 x 24	610 x 610	22 1/2 x 22 1/2	2	12	5.5

Duct opening is nominal door size - 1 1/2" (38mm)
For detailed specifications see submittal sheet

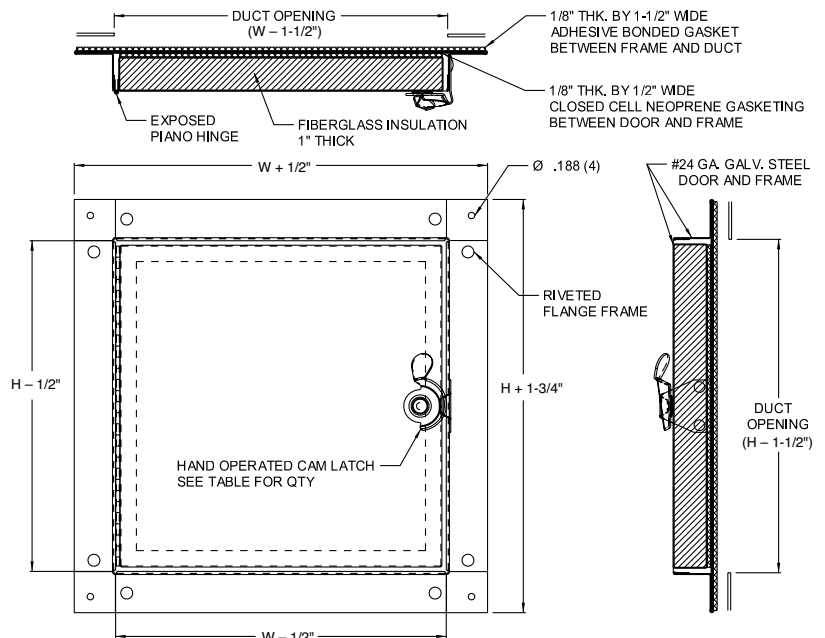

For more information on Acudor Products Inc. visit www.acudor.com or call 800.722.0501

Product specifications may change without notice. Acudor is a registered Trade Mark ©2014