

# SUBMITTAL DATA SHEET

NL Plug Style Corporation Stop – 74701T

AWWA/CC x T CTS Compression

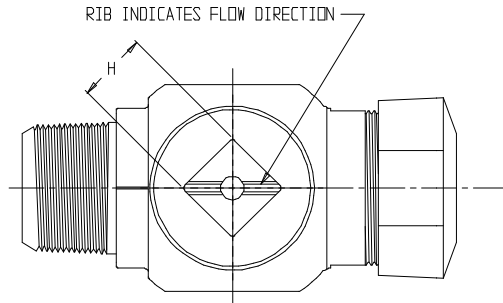
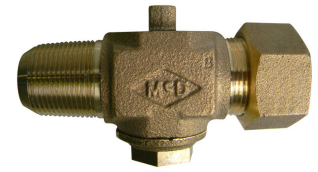

\*NOTE: 1 1/2 & 2 INCH PLUGS HAVE SQUARE HEAD WRENCHING SURFACES

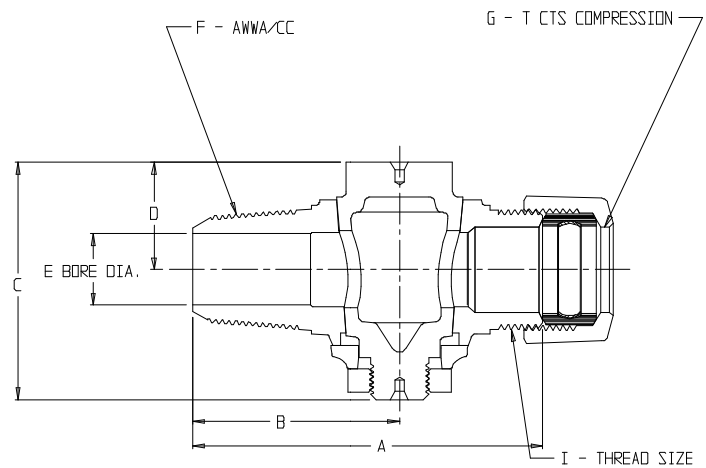
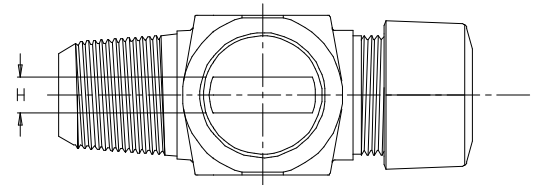

MODEL	SIZE	A	B	C	D	E	F	G	H	I
74701T	5/8 X 3/4	3.38	2.02	2.33	1.10	.63	5/8	3/4	.34	3/4 AWWA FLARE
74701T	3/4	3.66	2.15	2.50	1.13	.75	3/4	3/4	.38	3/4 AWWA FLARE
74701T	3/4 X 1	3.87	2.15	2.50	1.13	.75	3/4	1	.38	1 AWWA FLARE
74701T	1	4.25	2.40	2.89	1.41	1.00	1	1	.38	1 AWWA FLARE
74701T	1 1/4	5.31	2.94	3.44	1.67	1.25	1 1/4	1 1/4	.44	1 1/4 AWWA FLARE
74701T	1 1/2	6.06	3.35	4.26	1.98	1.50	1 1/2	1 1/2	*1.13	2 1/8 - 16 SPECIAL
74701T	2	7.30	3.97	4.80	2.39	2.00	2	2	*1.25	2 5/8 - 16 SPECIAL
74701TFT	1 1/2	6.23	3.35	4.26	1.98	1.50	1 1/2	1 1/2	*1.13	1 1/2 AWWA FLARE
74701TFT	2	7.30	3.97	4.80	2.39	2.00	2	2	*1.25	2 AWWA FLARE

## SUBMITTAL INFORMATION

- Manufactured in compliance with ANSI/AWWA C800 (latest revision)
- Brass components in contact with potable water conform to ASTM B584, UNS C89833 (latest revision) and identified with "NL"
- Certified to NSF/ANSI 61 and NSF/ANSI 372
- Brass components not in contact with potable water conform to ASTM B62 and ASTM B584, UNS C83600 -85-5-5-5 (latest revision)
- Large wrench flats provided for proper installation
- Plug rotates 360°
- 1/2" – 1" rated for 100 PSIG water pressure
- 1 1/4" – 2" rated for 80 PSIG water pressure
- Insert stiffeners required on all flexible plastic connections



**A.Y. McDonald Mfg. Co.**  
P.O. Box 508  
Dubuque, IA 52004-508

**Toll Free: 1-800-292-2737**  
**Fax: 1-800-832-9296**  
**Hours: 7:00 a.m. – 5:00 p.m., CST**

sales@aymcdonald.com  
[www.aymcdonald.com](http://www.aymcdonald.com)

A.Y. McDonald considers the information on this assembly drawing correct when published. Item and option availability, including specifications, are subject to change without notice.

Submitted by:

09-14